

DESCO INDUSTRIES INC. Technical Bulletin TB-7047

Micastat® Dissipative Laminate Installation and Maintenance

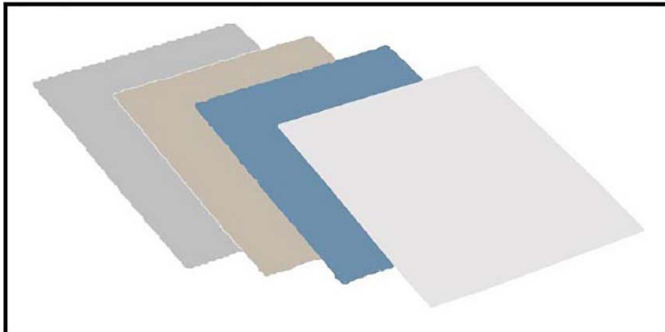

Figure 1. Micastat® Protective Laminate
ESD Grey, ESD Beige, ESD Blue, ESD White

Description

Micastat® is a high pressure static dissipative laminate designed for workbench tops used in the manufacture and assembly of ESD susceptible electronic components. Micastat® meets ANSI/ESD S20.20 requiring Rtg 1×10^9 ohms per ANSI/ESD S4.1 and antistatic low charging materials <math>< 200</math> volts per ANSI/ESD STM4.2. Its patented* multi-layer construction features a conductive layer which ensures dissipative properties independent of ambient humidity. Micastat® shows superior abrasion resistance and provides rapid, non-sparking charge dissipation. It can be laminated to plywood, fiber board, particle board tables and bench tops with conventional contact adhesives. It is resistant to most solvents and greatly exceeds the NEMA specification for wear resistance.

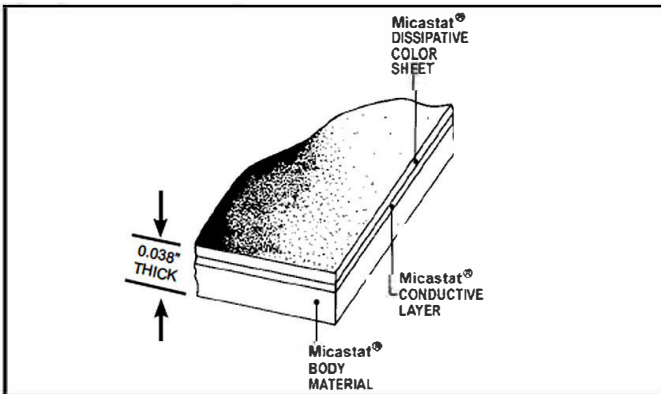

Figure 2. Micastat® layered construction

Installation

Micastat® is designed to be laminated to wooden tables or bench tops with conventional contact adhesive and will perform very well in the most rigorous postforming applications to a minimum of 5/8" (15.9mm) radius. Desco Industries, Inc. suggests the use of a high quality solvent

or water-based contact cement, white glue (PVA), epoxy, and hot melt glue. Consult your adhesive supplier for specific application requirements. Micastat® is a universal grade laminate for use in general purpose, postforming and high wear applications. For details on the installation of Micastat® and other high pressure laminated plastic sheets refer to National Electrical Manufacturers Association (NEMA) publication LD 3-1995 or follow these step by step directions for non-postforming applications.

1. Prepare the face of the substrate. It should be clean, dry and free of all contaminants which would interfere with adhesion. Caution should be taken when removing sheets and pads from its box, sheets and pads are high pressure laminate plastic and can be susceptible to cracks and breaking if not conditioned before handling and installation at 70 to 75 °F (21.1°C to 23.8°C) and 45-50% RH for 48 hours.
2. Stir the adhesive thoroughly and apply an even coat of adhesive by either spray, roller or brush to both the substrate face and the Micastat® back. Do not allow coated surfaces to touch. Allow the cement to dry. When bonding to plywood, apply a second coat if the first coat completely penetrates the wood. Use uncoated wood strips to assist in connecting coated surfaces.
3. Place thin, uncoated, wooden strips 12 inches apart across the substrate face. This will keep coated surfaces apart; bonding will occur once contact is made.
4. Position the over-cut Micastat® sheet on top of the wooden strips.

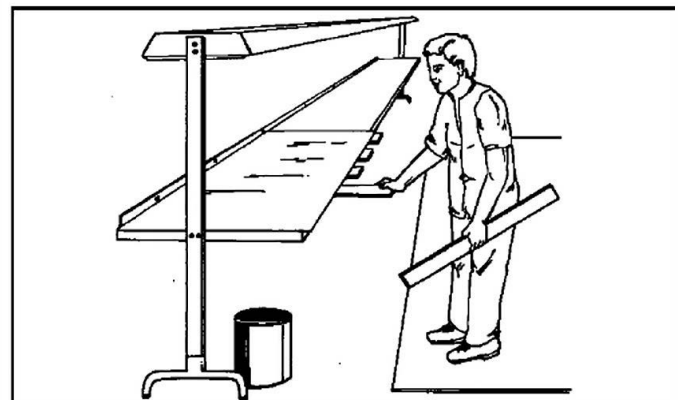

Figure 3. Micastat® sheet on wooden strips

*Micastat® is a registered trademark of Desco Industries, Inc. and is manufactured under one or more of the following U.S. patents: 4,455,350, 4,589,954, 4,645,717, 4,454,199.

5. Slowly remove strips of wood taking care to keep the Micastat® in position. The Micastat® should fall into position.
6. Push the laminate down with even hand pressure.
7. If the Micastat® falls out of position, squirt solvent (Desco Industries, Inc. recommends the use of ST102 solvent from Pionite) between the two surfaces and gently lift the Micastat® sheet up. Wait a minimum of 4 hours before reapplying another coat of adhesive, solvent must evaporate totally. Apply another coat of adhesive to both surfaces and reposition.
8. When Micastat® is in the correct position, seal the bond with a rubber "J" roller or a carpeted block and rubber mallet. Use either roller or block and mallet in a pattern that forces any air bubbles out from underneath laminate. If Micastat® sheet is oversized, sheet can now be trimmed with a router. After trimming, edges should be filed for a smooth splinter free edge.
2. The radiused edge of substrate must be smooth, rounded, and free of irregularities and loose particles.
3. Lead-in cracks may be minimized by ensuring a smooth cut on the edge of the laminate.
4. Always bond Micastat® to a suitable substrate such as medium to high density fiberboard, or particleboard. It should not be glued directly to plaster walls, gypsum wallboard, concrete, or metals.
5. Recommended adhesives include solvent or water-based contact cement, white glue (PVA), epoxy, and hot melt glue. Consult your adhesive supplier for specific application requirements.
6. The use of a backing sheet is recommended to minimize warpage. The thickness of the backing sheet should be relatively equal to the thickness of the decorative laminate on the face of the assembly.
7. The decorative surface to be formed should be heated to a temperature of 325°F to 375°F (165°C to 190°C).
8. Heat the Micastat® "wings" only, to 325°F to 375°F (165°C to 190°C) with a Chomelux heater held 2" to 2.5" from the surface. Tempilaq® liquid temperature indicator or equivalent should be used to determine the temperature.
9. The desired heat-up rate of 325°F (165°C) should be one second for every 0.001" of thickness (i.e., 30 seconds for .028", 38 seconds for .038").
10. Forming should be accomplished within 5 seconds of achieving proper surface temperature.
11. Heat up rates of laminate are affected by thickness, color, and finish. Temperatures should be verified by temperature-indicating wax (Tempilaq®).
12. Let the Micastat® laminate cool for five to ten minutes under pressure.

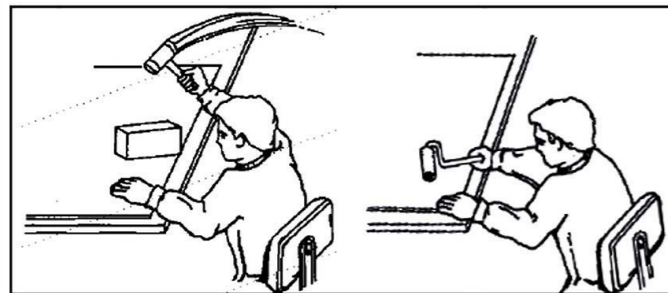

Figure 4. Wooden block and rubber mallet and "J" roller technique.

Once installed, Micastat® must be grounded to ensure proper charge dissipation. Refer to general grounding guidelines on this page.

Postforming Application

When the universal grade Micastat® is exposed to a temperature of 325°F (165°C) it will soften momentarily, allowing a straight line bend to be made. This bend should be made quickly and uniformly and have a radius equal to or greater than 5/8" (15.9mm). The chemical change that takes place in this process cannot be reversed; Micastat® cannot be reheated. Proper postforming machinery and close attention to details such as time and temperature are essential for best results. Preinstallation storage conditions are critical to postforming performance.

For detailed postforming information please refer to NEMA publication LD 3-1995 or follow these general directions.

1. Micastat® should be conditioned at 70 to 75 °F (21.1°C to 23.8°C) and 45-50 percent relative humidity for 48 hours prior to postforming. Recommended postforming machinery includes Midwest Automation and Evans Rotatorque.

Fabrication Tips

1. All saw blades and router bits used for cutting should be carbide tipped. Feed rate should be slow and tool speed should be high. To minimize the development of surface scratches caused by router bits, lubricating the laminate edge with a wax stick is recommended prior to tooling.
2. Inside corners of cutouts for electrical outlets, sinks, etc., should have a minimum radius of 1/8" (3mm) and should be filed smooth. This reduces the likelihood of stress cracks.

3. All edges of laminate should be filed smooth with file direction towards substrate to help prevent stress cracks and to minimize chipping.
4. When nails or screws must be used, it is advisable to first drill an oversized hole through the laminate. This reduces the likelihood of stress cracks.
5. Micastat® is intended for interior use only, and should not be exposed to extreme humidity, continuous sunlight, or temperatures above 275°F (135°C) for extended periods of time.
6. Work surfaces must be grounded for proper static dissipation.

For more information on the characteristics of nonindustrial laminates related to end-user applications please refer to National Electrical Manufacturers Association, publication LD 3-1995. The address for NEMA is:

NEMA
1300 North 17th Street, Suite 1847
Rosslyn, Virginia 22209

Phone: 703-841-3200
Web: www.nema.org

Once installed, Micastat® must be grounded to ensure proper charge dissipation. See below.

General Grounding Guidelines

1. When grounding Micastat®, it is essential to make intimate contact with the conductive layer which is directly below the dissipative, color layer. See the diagram on page 1 showing the multi-layered construction.
2. For proper and safe ESD protection, the grounding wire must be tied directly to and at the same potential as the facility power ground or "green wire" ground. A typical "green wire" ground if properly wired is the screw of a switch or outlet cover plate.
3. If power is to be used at the ESD protected workstation, per ANSI/ESD S20.20 paragraph 5, a Ground Fault Circuit Interrupter (GFCI) is recommended.
4. Test all workstation grounds for proper resistance to ground. See Desco's Technical Bulletin [TB-2007](#) for a complete discussion of grounds as used in the U.S. For information on instruments and procedures for the proper testing of grounds we recommend that you contact ECOS Electronics, 205 Harrison Street, Oak Park, IL 60304, (708) 383-2505, Fax (708) 383-2137.

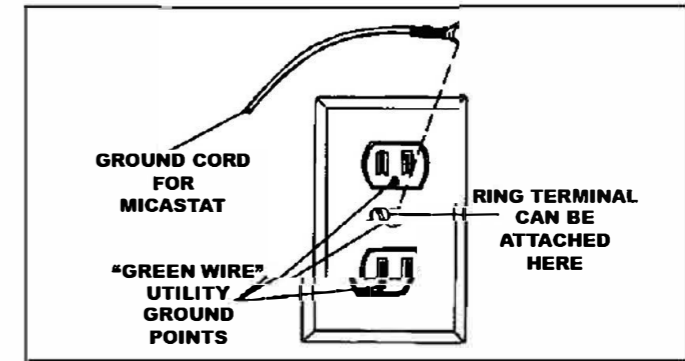

Figure 5. Outlet plate with "green wire" ground

5. The selection of ground cords is intimately related to the organization's material handling procedures. It is important for a user to be familiar with his/her own organization's grounding specifications and ESD procedures prior to selecting ground cords. See paragraph 2 in Cautions section of this Technical Bulletin.

Grounding Methods for Installed Sheet Goods

Desco Industries, Inc. offers two styles of ground systems that will ground your static dissipative laminate worksurface: Laminate Grounding System and Flush Mount Laminate Ground Insert. These ground assembly kits are for use when the laminate sheet is installed on a wooden workbench top.

1. The Laminate Grounding System contains all the items needed to properly ground a permanently installed Micastat® top. This includes a 10 foot grounding wire terminated with a one megohm resistor and No. 10 ring terminal and a grounding bolt complete with single wrist strap banana jack connection terminal.

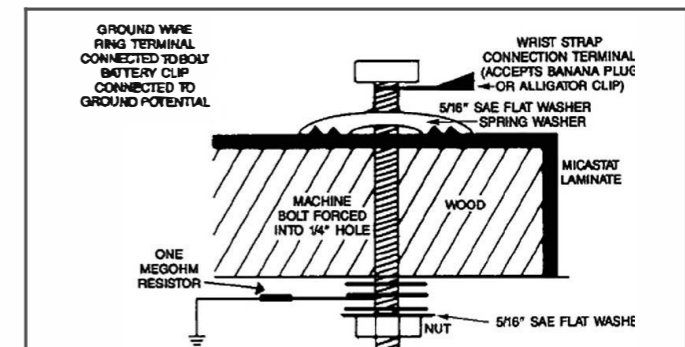

Figure 6. Installation of the Laminate Grounding System.

2. The Flush Mount Laminate Ground Insert with Bench is also available without a dual wrist strap ground sold as an Flush Mount Inserts. Both the Flush Mount Inserts and Flush Mount Laminate Ground Insert can be easily installed with our Drill Kit.

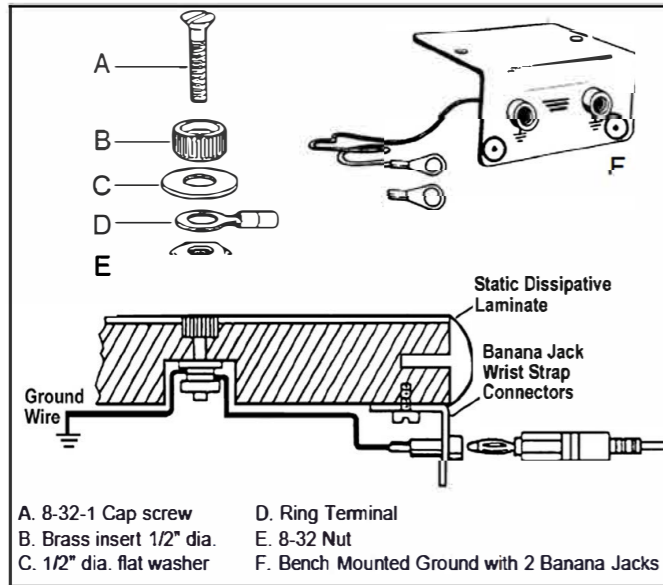

Figure 7. Component Parts and Installation of the Flush Mount Inserts and the Flush Mount Laminate Ground Insert.

Installing the Flush Mount Insert Ground System

The following instructions are based on a top with a thickness of 1-1/4" (30mm) tops.

2.1. Using the Flush Mount Drill Tool:

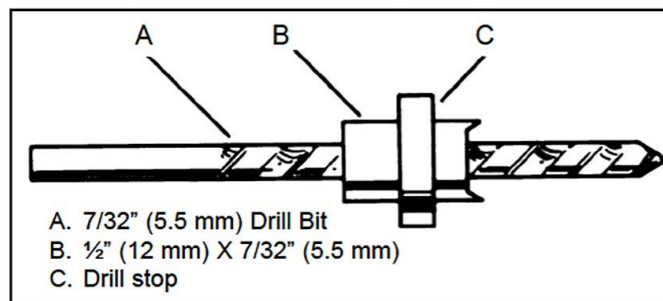

Figure 8. Drill Tool.

- a. Set the 7/32" (5.5mm) drill bit and adjustable counterbore so that the 7/32" (5.5mm) bit will drill clear through the work surface.
 - b. Set the drill stop so the drilling depth of the 1/2" (12mm) counterbore is .200" (5.1mm) (+.000" - .010")
- 2.2. Using the drill kit as adjusted above, position drill bit on the top of the worksurface at the point you want to install the flush mount insert.
 - 2.3. Drill perpendicular from the top surface straight into the work surface until the drill stop touches the laminate surface. This should be at a depth of .200" (5.1mm).
 - 2.4. Using the 7/32" (5.5mm) pilot hole on the bottom of the work surface drill a 1 1/2" (37mm) diameter

- counterbore 5/8" (16mm) deep, of no more than 1/2 the thickness of the worksurface.
- 2.5. Seat the 8-32 cap screw through the brass insert so that it sits flat with the top of the insert.
- 2.6. Push the cap screw and brass insert assembly into the 1/2" (12mm) diameter hole on top of the worksurface. Attach and tighten the 8-32 nut until the brass insert is flush with the laminate surface.
- 2.7. Remove the 8-32 nut and install the flat washer, ring terminal and 8-32 nut as shown above. The ring terminal is for a ground wire attachment.
- 2.8. Using approximately 22 gauge wire, crimp the supplied ring terminal to the wire and secure it to the 8-32 cap screw using the 8-32 nut. Attach the unterminated wire end to a building ground. **THE MICASTAT® WORKSURFACE IS NOW GROUNDED.** Recommended practice per ANSI/EOS/ESD S6.1-1991 is no resistor between the common point ground terminal and a worksurface, floor mat, or shelving.
- 2.9. FOR INSTALLING dual wrist strap ground included. Place the Bench Mounted Ground Wire at the position desired to install, screw in place using enclosed screws.
- 2.10. Using the ground wire from the Bench Mounted Ground Wire, cut the length of the ground cord so that it will reach from the Bench Mounted Ground Wire to the underside of the worksurface at the 8-32 screw. Crimp the extra ring terminal to the end of the wire and bolt it to the underside of the work surface using the 8-32 cap screw and nut.
- 2.11. Using the remaining wire cut from the Bench Mounted Ground Wire, attach the ring terminal end to the 8-32 cap screw and nut. Using the ring terminal enclosed, terminate the other end to a ground source. This will GROUND both the Micastat® top and the dual wrist strap ground.

Grounding Method for Continuous Monitors

Materials Needed for Dual Operator and Dual Wire Monitors:

- 2 ea. Flush Mount Laminate Ground Insert
 - 1 ea. Installation Tool for Flush Mount Insert
1. Install the Flush Mount Inserts first. It is recommended to install one in the right back corner and the other in the left back corner of the Micastat® laminated bench top.
 2. Once both inserts are installed, cut the ground cord supplied with the monitor into two pieces; make sure that the tinned end is long enough to connect from the monitor to one of the flush mount terminals located under the bench.

3. The remaining wire can then be used to connect the other flush mount terminal to ground using the supplied ring terminal. The shrouded molded end can then be cut off.

When complete, one flush mount terminal will connect the Micastat® laminate to ground, while the other will connect it to a monitor. The monitor then monitors the ground connection between the two inserts, and since Micastat® is the only ESD laminate made with a physical uniform ground layer, it will monitor the entire Micastat® surface ground. The wires will stay under the bench, maximizing the usable space on the bench top.

Materials Needed Mini Workstation Monitor:

- 2 ea. Flush Mount Laminate Ground Inserts
 - 1 ea. Installation Tool for Flush Mount Insert
 - 1 ea. 10mm Socket and Rivet (100 per pack)
 - 2 ea. 8-32 button cap screws
1. Install the Flush Mount Inserts in the snap pattern for the monitor.
 2. Once installed, remove the 8-32 taper head screw supplied.
 3. Place a 10mm snap socket on top of the installed Flush Mount Laminate Ground brass insert.
 4. Screw the 10mm snap socket into place on the insert using an 8-32 button cap screw.
 5. Do this for both inserts and snap attach the Mini Monitor into place; it is now grounded to and monitoring the Micastat®.

Grounding Method for Micastat® Pads

Micastat® Pads have the same dissipative characteristics as Micastat® Sheet. The pads have pressure sensitive adhesive on the underside for rapid and secure installation. They are packed complete with an installed, 10mm (.395") snap socket and a Common Point Ground Cord. The Common Point Ground provides banana jack receptacles for two wrist straps.

1. Remove the protective carrier from the pressure sensitive adhesive. Lay the Micastat® Pad in position and snap on

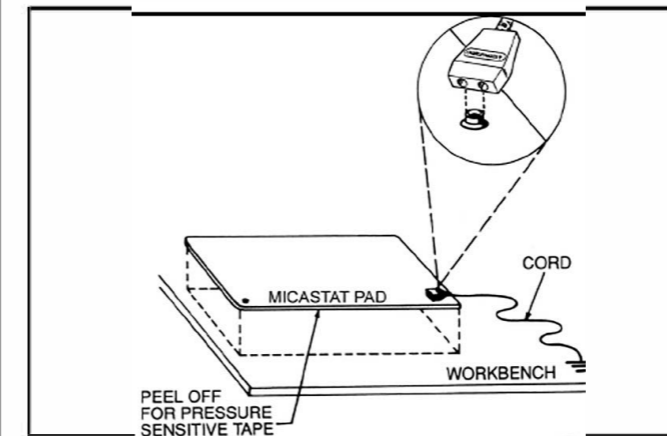

Figure 9. Proper installation of Micastat® Pad.

the ground cord. Bring the other end of the ground cord to a "green earth ground" and attach it using the ring terminal. A suggested "green earth ground" is the center screw of a standard outlet. Testing is recommended to ensure that the screw is properly grounded. If there is excess wire you may want to cut and strip the ground wire to a shorter length and attach it with another ring terminal, which is included with each ground cord.

Cautions

1. Only one (1) groundable point should exist on any ESD protective work surface or floor mat. ESD protective workstation components, such as work surfaces, should never be grounded in series (daisy chained).

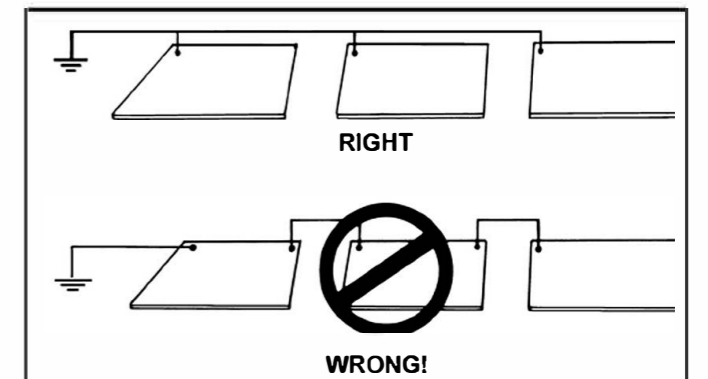

Figure 10. Work surfaces should NEVER be daisy chained.

2. The Common Point Ground Cord shipped with the Micastat® Pad has a 1 Megohm resistor. A non-resistor Common Point Ground Cord, may be purchased separately.
3. The ESD-S1-1 Standard calls for a 1 megohm current limiting resistor in the wrist straps used with an ESD protective work surface such as Micastat® Pads or Sheets.
4. ESD Handbook TR20.20 worksurface 5.3.1.9.3 High Pressure Laminates. These materials are rigid and are applied to a substrate, typically with adhesive systems. The majority of these materials follow the multi-layer description above. There are, however, some types that are basically homogeneous in construction.

Because the electrical properties of many high pressure laminates have some degree of humidity dependence, all high pressure laminate materials should be carefully tested for adequate performance at low humidity prior to selection and installation.

Multi-layer Micastat® with conductive layer is not homogenous and is not humidity dependent.

Testing

There are two types of tests for monitoring Micastat® surface electrical characteristics. One type of test is Rtg - Resistance to Ground (see Figure 7). In this test you measure the resistance of the laminate surface to the installed ground bolt.

A second type of test is Rp (Resistance, Point to Point). Here you measure the resistance from one 2.27kg. probe to another 2.27kg. probe; see probe test positions A, B, C, and D in Rp test diagram, Figure 13. This is the test that is more often used in the laboratory to determine Micastat® compliance with electrical specifications.

Resistance To Ground (Rtg):

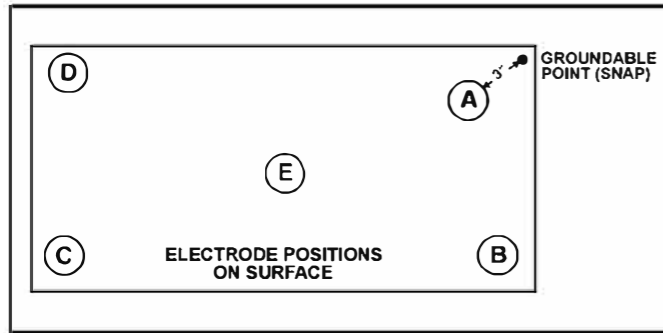

Figure 11. Electrode positions on surface of pad, Rtg test.

1. Locate the five electrode positions, as described below, to be used on the Micastat® surface in relationship to the installed ground bolt (or snap on the Micastat® Pad). Use the relative positions shown above.

A - At least 50 mm from any surface edge and 75 mm from the ground bolt.

B, C & D - The furthest corners from the ground bolt and 50 mm from any surface edge.

E - The geometric centre of the surface.

2. Disconnect the surface to be tested from its normal ground connection.

3. Connect one black lead to the meter and the other end of this lead to the 2.27 kg electrode.

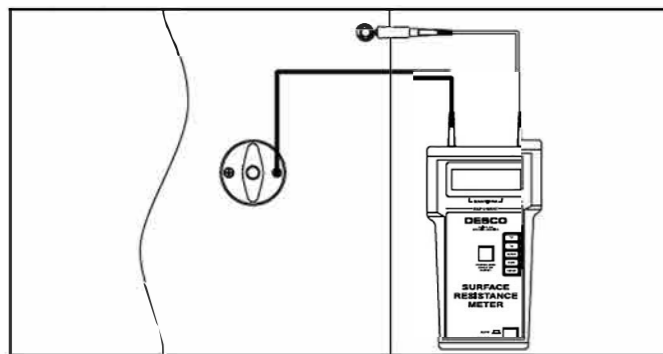

Figure 12. Proper connection of leads.

4. Connect the other black lead to the meter and the groundable point on the mat.
5. Place the electrode at position A on the mat (see the Rtg diagram) and set the meter selector switch to 100V.

6. Push on On/Off button, wait 15 seconds and then record the reading in ohms.
7. Release the On/Off button. Move the electrode to each of the other four positions on the surface and repeat the test.
8. Average the results of the five readings to obtain an average measurement of the resistance of surface to ground.

Resistance Point to Point (Rtt):

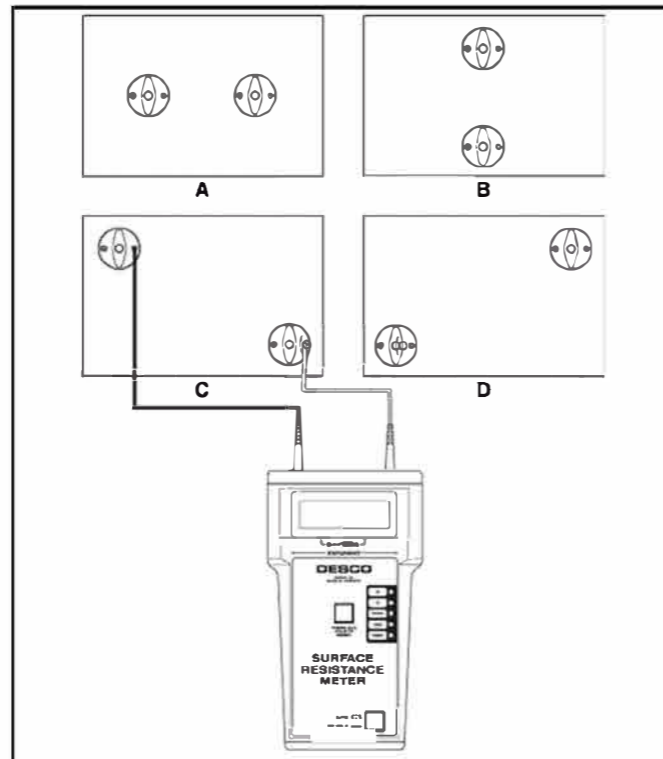

Figure 13. Electrode positions on surface of pad, Rtt test.

1. Locate the four pair of electrode positions to be used approximately as shown in the Rtt test diagram above. Position electrodes at least 250 mm apart and not less than 50 mm from any edge.
2. Disconnect the surface to be tested from its normal ground connection.
3. Connect one end of the black lead to the meter. Connect the other end of this lead to either one of the electrodes. It does not matter which lead is connected to which weighted electrode.
4. Connect the other lead to the meter. Connect the other end to the other weighted electrode.
5. Place the electrodes in position A as shown in Rtt test diagram (Fig. 9). Set the meter selector switch to 100V.
6. Push the On/Off button, wait 15 seconds and then record the reading in ohms.

7. Release the On/Off button. Move the electrode to each of the other three positions on the surface and repeat the test.
8. Average results of the four readings to obtain an average measurement of the resistance of the surface between two points.

Maintenance

1. It is important to store Micastat® laminate sheets at the same relative humidity as the material to which it will be bonded. This will prevent a moisture imbalance in application.
2. Micastat® may swell slightly if a damp object is kept in continuous contact with the surface for more than 12 hours. This is normal; the swelling will disappear soon after the damp object is removed.
3. Micastat® may be cleaned with Reztore® Antistatic Surface and Mat Cleaner, Item No. 71021 or any household soap solution. Be careful that household soaps do not leave an insulative layer behind. This will reduce electrical properties. Difficult stains may be removed with organic solvents such as acetone, alcohol, methyl ethyl ketone (MEK) or paint thinner.

Limited Warranty, Warranty Exclusions, Limit of Liability and RMA Request Instructions

See Desco Industries Inc. Warranty
<http://www.descoindustries.com/Warranty.aspx>

RoHS 2, REACH, and Conflict Minerals Statement

None of the RoHS 2 restricted materials or REACH substances of very high concern as of 2015/12/17, or Conflict Minerals are intentionally added in manufacturing this product. Ref: European Union Directive 2011/65/EU and Regulation (EC) No. 1907/2006/CE. See [Limited Warranty Information](#) of Desco Industries, Inc.

"It should be understood that any object, item, material or person could be a source of static electricity in the work environment. Removal of unnecessary nonconductors, replacing nonconductive materials with dissipative or conductive materials and grounding all conductors are the principle methods of controlling static electricity in the workplace, regardless of the activity." [ESD Handbook TR 20.20 section 2.4]

Micastat® is available from these Desco Industries brands:



for service and support in North America

Sheet Size	Beige	Blue	Grey	White
30" x 10' (0.8m x 3.0m)	10200	10180	10290	10240
30" x 12' (0.8m x 3.7m)	10202	10181	10291	10242
36" x 8' (0.9m x 2.4m)	10203	10182	10292	10243
36" x 10' (0.9m x 3.0m)	10204	10183	10293	10244
36" x 12' (0.9m x 3.7m)	10206	10184	10294	10246
48" x 8' (1.2m x 2.4m)	10208	10185	10295	10248
48" x 12' (1.2m x 3.7m)	10212	10187	10297	10252
60" x 12' (1.5m x 3.7m)	10215	10190	10300	10255

Mat Top Size	Beige	Blue	Grey	White
24" x 36" (0.6m x 0.9m)	10310	10344	10342	10393
24" x 48" (0.6m x 1.2m)	10350	10384	10382	10394



for service and support in the U.K. and Europe

Sheet Size	Beige	Grey
30" x 8' (0.76m x 2.4m)	90022	90066
30" x 10' (0.76m x 3.0m)	90024	90068
30" x 12' (0.76m x 3.6m)	90026	90070
36" x 8' (0.91m x 2.4m)	90028	90072
36" x 10' (0.91m x 3.0m)	90030	90074
36" x 12' (0.91m x 3.6m)	90032	90076
48" x 8' (1.2m x 2.4m)	90034	90078
48" x 10' (1.2m x 3.0m)	90035	90079
48" x 12' (1.2m x 3.6m)	90036	90080
48" x 8' (1.5m x 2.4m)	90038	90082
60" x 10' (1.5m x 3.0m)	90040	90084
60" x 12' (1.5m x 3.6m)	90042	90086



for service and support in the U.K. and Europe

Sheet Size	Beige	Grey
30" x 10' (0.76m x 3.0m)	210960	210961
36" x 10' (0.91m x 3.0m)	210962	210963
36" x 12' (0.91m x 3.6m)	210964	210965
48" x 8' (1.2m x 2.4m)	210966	210967
48" x 12' (1.2m x 3.6m)	210968	210969
60" x 10' (1.5m x 3.0m)	210970	210971
60" x 12' (1.5m x 3.6m)	210972	210973

Test Equipment Depot - 800.517.8431 - 99 Washington Street Melrose, MA 02176 - TestEquipmentDepot.com