

WAL025974

WaveLEDT70BI8008403,5DCLAESDNA

Old item no.: 18902BK

EAN-nr: 7040670259745

Stock code: B



Wave LED-ESD is an illuminated magnifier designed for use in static-sensitive environments where electrostatic discharges can prove fatal for electronic components. The shade and arm are powder-coated with a metal-laced paint that measures $10^4\Omega/\text{sq}$. (conductive). The remaining components are molded in a material that measures $10^5 - 10^6\Omega/\text{sq}$. (static dissipative). Since the surfaces are no longer insulative, triboelectric charging results in drastically lower voltages, especially since any charge (under 50 volts) is uniformly distributed throughout the entire surface of the head assembly. No knobs to tighten, nothing to adjust - a flexible, self-balancing shade and hands-free neck assembly combined with 30" heavy-duty internal-spring parallel, three-pivot K-arm, allows the lamp head to be secured in any position. The fully-enclosed neck design is ideal for environments where FOD is a concern. An automatic shut-off feature and step dimming further ensures energy savings. WAVE LED offers shadow-free 3.5-diopter (1.88X) magnification with light coming from both sides as well as three-dimensional

Lightsource	
Number of lamps	2
Lightsource	LED
CRI and/or Color Temperature	80 CRI, 4000K
Lamp power (W)	12
Lumen/Watt	59
LLMF LED 50000h Ta25	0.80
Average useful life (IEC 62717) Ta25	50000
Lumen Out	764
Technical data	
Maximum ambient temperature (°C)	25
IP classification	20
ESD-Safe	Yes
Termination	
Plug type	NA
Cord length (ft)	5
Mounting	Edge clamp



Electrical data	
Maximum voltage (V)	240
Maximum frequency (Hz)	60
Minimum frequency (Hz)	50
Voltage from (V)	110
Total consumption (W)	13
Optic	
Primary Lens (D)	3.5
Working distance (mm)	285.7
Magnification (X)	1.88
Dimensions	
Net weight (kg)	4
Arm length (in.)	30
Body	
Body color	Black

Test Equipment Depot - 800.517.8431 - 99 Washington Street Melrose, MA 02176

TestEquipmentDepot.com

WAL025974

Drawings

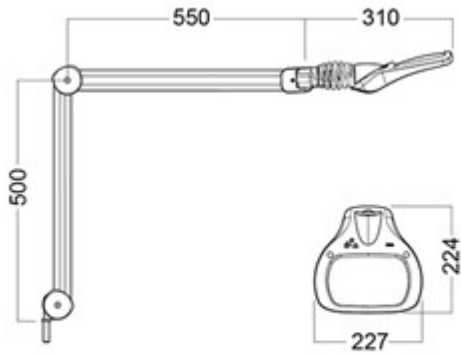

Test Equipment Depot - 800.517.8431 - 99 Washington Street Melrose, MA 02176
TestEquipmentDepot.com