

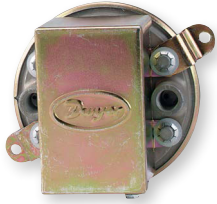

Series 1900 Pressure Switch

Specifications - Installation and Operating Instructions



Series 1910 pressure switch. All pressure and electrical connections and set point adjustments are on one side for easy installation.

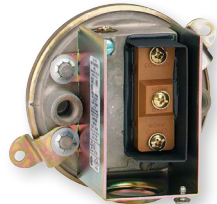

Series 1910 switch with conduit enclosure off. Shows electric switch and set point adjustment screw.

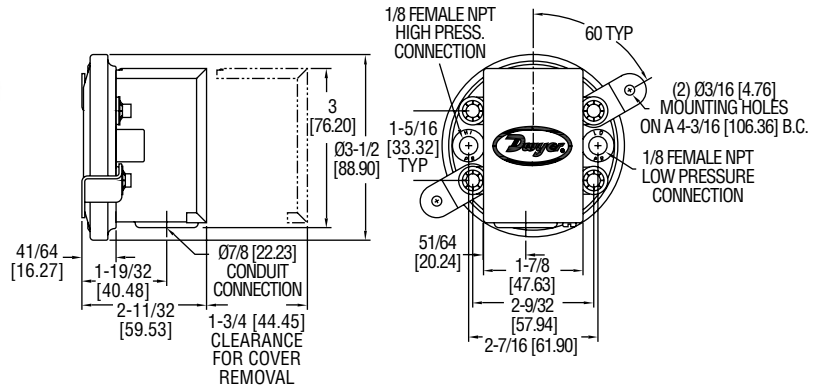

The Dwyer-engineered force-motion amplifier increases the leverage of diaphragm movement and results in a switch with excellent sensitivity and repeatability.

Advanced design and precision construction permit these switches to perform many of the tasks of larger, costlier units. Designed for air conditioning service, they also serve many fluidics, refrigeration, oven and dryer applications. For use with air and non-combustible gases. Series 1900 switches are available with set points of 0.07 to 20 inches water column. Set point adjustment can be made easily - before or after installation. Range screw is inside conduit enclosure to help prevent tampering. For easy mounting and access, pressure and electrical connections and set point adjustment are located on one side. This permits installation in corners or spaces too small for other switches.

SPECIAL MODELS & ACCESSORIES

Special close coupled street elbow for right angle pressure connections. Can be installed on switch anytime. Zinc plated aluminum.

Weatherproof Housing

16 ga. steel enclosure with gasketed cover (NEMA 4) for wet or oily conditions. Withstands 200 hour salt spray test. Wt. 5 lbs. (2.3 kg). Switch must be factory installed. Change 1910 base number to 1911 and add -WP suffix. Example: 1911-1-WP.

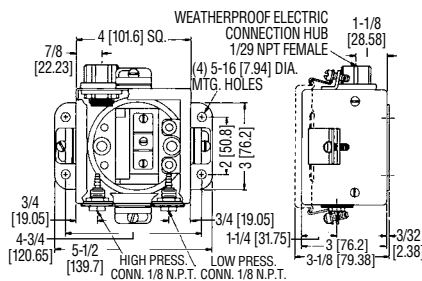

Explosion-Proof Housing

NEMA 7, 9 NEMA 3. (7 lbs). Switch must be factory installed. Change model to 1911 and add -EXPL suffix. Example: 1911-1-EXPL. Aluminum base and cover rated Class I, Groups C & D, Div. 1. Class II, Groups E, F, & G, Div. 1.

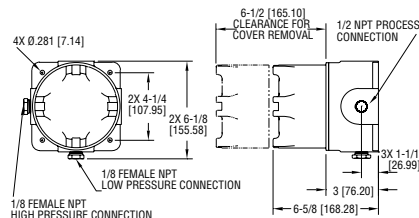

SPECIFICATIONS

Service: Air and non-combustible, compatible gases.
Environment: Standard model intended for indoor use.
Wetted Materials: Consult factory.
Temperature Limits: -30 to 180°F (-34 to 82.2°C) (32°F for non dry air).
Pressure Limits: 45" w.c. (11.2 kPa) continuous, 10 psig (68.95 kPa) surge.
Humidity Limit: 80% RH (non-condensing).
Altitude Limit: 6560 ft (2000 m) max.
Switch Type: Single-pole double-throw (SPDT).
Repeatability: ±3%.
Electrical Rating: 15 A @ 120-480 VAC (~), 60 Hz. Resistive 1/8 HP @ 125 VAC(~), 1/4 HP @ 250 VAC(~), 60 Hz. Derate to 10 A for operation at high cycle rates.
Electrical Connections: 3 screw type, common, normally open and normally closed.
Installation Category: III (transient over-voltage).
Process Connections: 1/8" female NPT.
Mounting Orientation: Diaphragm in vertical position. Consult factory for other position orientations.
Set Point Adjustment: Screw type inside conduit enclosure.
Pollution Degree: 2.
Weight: 1lb. 4.5 oz. (581 g).
Agency Approvals: CE, UL, CSA, FM.

Explanation of Symbols

Symbol	Publication	Description
~	IEC 60417 - 5032	Alternating current
⊕	IEC 60417 - 5019	Protective conductor terminal

Series 1910 Switches - Models Operating Ranges, Deadbands

Model	Operating Range, in w.c.	Approximate Dead Band	
		At Min. Set Point	At Max. Set Point
1910-00	0.07 to 0.15	0.04	0.04
1910-0	0.15 to 0.5	0.10	0.10
1910-1	0.40 to 1.6	0.15	0.16
1910-5	1.40 to 5.5	0.30	0.30
1910-10	3.0 to 11.75	0.40	0.40
1910-20	4.0 to 20.0	0.40	0.50

INSTALLATION

1. Select a location that is free from excessive vibration, corrosive atmosphere and where the ambient temperature is within the limits for these switches.

2. Mount standard switches with the diaphragm in a vertical plane and with switch lettering and nameplate in an upright position. Some switches are position sensitive and may not reset properly unless they are mounted with the diaphragm vertical. (Special units can be furnished for other than vertical mounting arrangements if required.)

3. Connect switch to source of pressure, vacuum or differential pressure. Metal tubing with 1/4" O.D. is recommended, but any tubing which will not restrict the air flow can be used. Connect to the two 1/8" female NPT pressure ports as noted below:

- Differential pressures - connect pipes or tubes from source of greater pressure to high pressure port marked HI-PR and from source of lower pressure to low pressure port marked LO-PR.
- Pressure only (above atmospheric) - connect tube from source of pressure to high pressure port. The low pressure port is left open to atmosphere.
- Vacuum only (below atmospheric pressure) - connect tube from source of vacuum to low pressure port. The high pressure port is left open to atmosphere.

CAUTION Power must be off while wiring connections are being made.

4. Electrical connections to the standard single pole, double throw snap switch are provided by means of screw terminals marked "common", "norm open", and "norm closed". The normally open contacts close and the normally closed contacts open when pressure increases beyond the set point.

CAUTION Do not exceed the specified voltage rating. Permanent damage not covered by warranty may result.

5. Switch loads should not exceed the maximum specified current rating of 15 amps resistive. Switch capabilities decrease with high load inductance or rapid cycle rates. Whenever an application involves either of these factors, the user may find it desirable to limit the switched current to 10 amps or less in the interest of prolonging switch life.

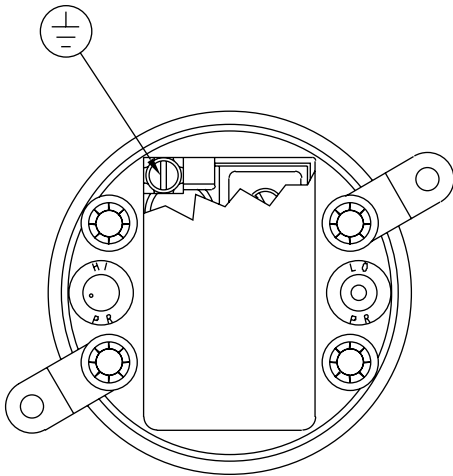

OPERATION

Pressure acting on the power diaphragm rotates the amplifying lever, which in turn extends the range spring and rotates the snap switch input lever. When the set point is reached, the snap switch is actuated and the electrical contacts make or break.

ADJUSTMENT

To change the set point, proceed as follows:

A. Remove the snap-on cover from the conduit enclosure by loosening its retaining screw and pulling firmly at its bottom end. Turn the slotted adjustment screw at the top of range spring housing clockwise to raise the set point pressure and counter-clockwise to lower the set point.

B. The recommended procedure for calibrating or checking calibration is to use a "T" assembly with three rubber tubing leads, all as short as possible and the entire assembly offering minimum flow restriction. Run one lead to the pressure switch, another to the manometer of known accuracy and appropriate range, and apply pressure through the third tube. Make final approach to the set point very slowly. Note that manometer and pressure switch will have different response times due to different internal volumes, lengths of tubing, fluid drainage etc. Be certain the switch is checked in the position it will assume in use, i.e. with diaphragm in a vertical plane and switch lettering and nameplate in an upright position.

C. For highly critical applications it is a good idea to check the set point adjustment and reset it as necessary once or twice in the first few months of operation. This will compensate for any change in initial tension which may occur in the spring and diaphragm. For most applications this change will not be significant and no resetting will be required.

MAINTENANCE

Moving parts of these switches are sealed in and are permanently tamper proof. The single adjustment is that of the set point. Care should be taken to keep the switch reasonably dry and free from dust or dirt. No lubrication or unusual precautions are required for normal use.