

DESCO TECHNICAL BULLETIN TB-3072

Mini Monitor Installation, Operation and Maintenance



Made in the
United States of America



Figure 1. Desco Mini Monitor

Description

The Desco Mini Monitor is a single workstation continuous monitor. It continuously monitors the path-to-ground integrity of one operator and one ESD worksurface. The Mini Monitor eliminates the need for periodic testing and record keeping of wrist straps.

The Mini Monitor is designed with Wave Distortion Technology which provides stable continuous monitoring of the path-to-ground and presence of 1 megohm resistance of an operator's wrist strap. Audio and visual alarms activate (in less than 50 milliseconds) when the operator unintentionally disconnects from the monitor or the wrist strap connection points are intermittent. The Mini Monitor also serves as a ground point for an ESD worksurface and monitors for a path-to-ground of less than 500 megohms. All Mini Monitors are calibrated to NIST standards and include a certificate.

WAVE DISTORTION

Wave Distortion Technology is the Most Reliable Technology for the Continuous Monitoring of Single-Wire (Conductor) Wrist Straps

"Wave Distortion" or vector impedance works by applying a continuous test voltage of 1.2 volts peak-to-peak at 1 to 2 microamperes (0.000002 amperes) to the wrist strap that is connected to the continuous or constant monitor. The test voltage creates a sine wave that the monitor circuit compares to established patterns. By monitoring the "distortions", or shape of the sine wave, Wave Distortion Technology determines if the monitored circuit is complete - the operator is in the circuit and the total equivalent DC resistance is within specifications. Wave Distortion Technology produces a very fast alarm time (<50 milliseconds) and minimal false alarms.

ANSI/ESD S20.20 section 7.3 states "Compliance verification records shall be established and maintained to provide evidence of conformity to the technical requirements." Per ANSI/ESD S1.1 Annex A.3 Daily (wrist strap system) testing may be omitted if constant monitoring used." Per ESD Handbook ESD TR 20.20 section 5.3.2.4.4 "Typical Test programs recommend that wrist straps that are used daily should be tested daily. However, if the products that are being produced are of such value that knowledge of a continuous, reliable ground is needed, and then continuous monitoring should be considered or even required."

The Mini Monitor and its accessories are available as the following item numbers:

Item	Description
19239	Mini Monitor, Black, North American Power Adapter
19242	Mini Monitor, Blue, with Jewel® Wrist Strap, North American Power Adapter
19243	Mini Monitor, Black, Universal Power Adapter
19258	Power Adapter, 100-240VAC Input, 24VDC 150mA Output, IEC Inlet
19260	Power Adapter, 100-240VAC Input, 24VDC 150mA Output, North America Plug
98221	Wave Distortion Monitor Verification Tester

Packaging

[19239](#) Mini Monitor, North America

- 1 Mini Monitor
- 2 Countersunk Washers
- 2 Flat Head Screw, 6-32 x 1/4"
- 1 Power Adapter, 24VDC, North America Plug
- 1 Certificate of Calibration

[19242](#) Mini Monitor, Jewel® Kit, North America

- 1 Mini Monitor
- 1 [09100](#) Jewel® Elastic Wrist Strap
- 2 Countersunk Washers
- 2 Flat Head Screw, 6-32 x 1/4"
- 1 Power Adapter, 24VDC, North America Plug
- 1 Certificate of Calibration



Figure 2. North American power adapter included with the [19239](#) and [19242](#) Mini Monitors

[19243](#) Mini Monitor, Universal Power Adapter

- 1 Mini Monitor
- 2 Countersunk Washers
- 2 Flat Head Screw, 6-32 x 1/4"
- 1 10mm Interchangeable Park Snap
- 1 10mm Operator Jack Adapter
- 1 Power Adapter, 24VDC, IEC Inlet
- 1 Certificate of Calibration



Figure 3. Universal power adapter included with the [19243](#) Mini Monitor

NOTE: The power cord must be purchased separately if ordering the [19243](#) Mini Monitor. The power cords are available as the following item numbers:

Item	Plug Type
50545	Europe
50546	United Kingdom

Features and Components



Figure 4. Mini Monitor features and components

A. Power Jack: Connect the included 24VDC power adapter here.

B. Operator LEDs: Illuminates green when the operator is properly grounded. Illuminates solid red and audible alarm sounds when the operator is not properly grounded.

C. Worksurface LEDs: Illuminates green when the worksurface is properly grounded. Illuminates red and audible alarm sounds when the worksurface is not properly grounded.

D. Park Snap: Allows the operator to disconnect (and park) a wrist strap when leaving the workstation, without creating a false alarm. Touch the park snap and the monitor's audible alarm will disable for approximately 10 seconds. Use this time to disconnect the wrist cord from the wristband, and attach it to the park snap or remove the banana plug from the jack. Upon returning to the workstation and disconnecting the wrist cord from the park snap, the operator has approximately 10 seconds to reconnect the wrist cord to a worn wristband before activating the alarm.

E. Monitored Operator Jack: Insert the single-wire wrist cord here to monitor the operator's connection to ground.

F. Threaded 10mm Ground Snap: Connects the worksurface mat to electrical ground.

G. Threaded 10mm Worksurface Monitor Snap: Verifies that the worksurface's path-to-ground is <500 megohms.

Installation

1. Remove the Mini Monitor from the carton, and inspect for damage.
2. Locate an appropriate AC outlet near the Mini Monitor, and test it for proper wiring and grounding prior to use. The Desco AC Outlet Analyzer or similar test equipment may be used to verify the outlet's functionality. Use item number [98132](#) for 120VAC North American outlets and item number [98131](#) for 220VAC UK outlets.
3. Determine the mounting location of the Mini Monitor. It is normally installed toward the front edge of a workstation where its LEDs can be visible to the operator. Use a blade to pierce two holes 1-5/16" apart from one another into the worksurface mat.
4. Use a Phillips screwdriver to secure the two flathead screws and countersunk washers through the worksurface mat and into the two threaded 10mm snaps on the bottom of the Mini Monitor.

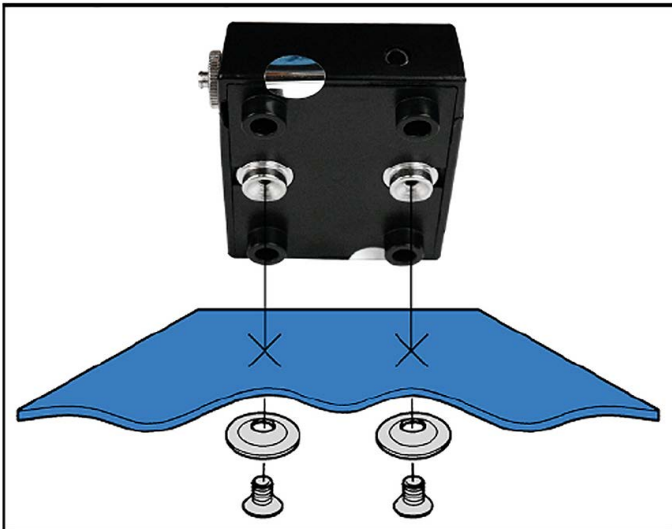

Figure 5. Securing the Mini Monitor to a worksurface mat

5. Connect the power adapter to the power jack located on the top-side of the Mini Monitor. Connect the wire from the supply to the tested AC outlet, and plug it into the outlet.

NOTE: Older revision Mini Monitors do not feature threaded 10mm snaps on their bottom-side. They require the use of push and clinch snaps to secure the monitor to the worksurface mat.

Installation onto Micastat® Laminate

Materials Needed:

- 2 [14244](#) Micastat® Flush Mount Ground Inserts
 - 1 [14242](#) Micastat® Flush Mount Insert Tool
 - 1 [09857](#) 10mm Socket and Rivet (100 per pack)
 - 2 8-32 Button Cap Screws
1. Install the two flush mount ground inserts into the Micastat® laminate. Space the inserts 1-5/16" apart from one another.
 2. Once the ground inserts are installed, remove the 8-32 screws that were supplied with the kits.
 3. Place 10mm snap sockets on top of the installed brass ground inserts.
 4. Screw the 10mm snap sockets into place on the ground inserts using the 8-32 button cap screws.
 5. Align the two snaps underneath the Mini Monitor to the two snaps on the Micastat® laminate. Apply downward force on the monitor once aligned to snap the Mini Monitor into place.
 6. Connect the power adapter to the power jack located on the top-side of the Mini Monitor. Route the wire from the supply to a nearby AC outlet and plug it into the outlet. Make sure the voltage and frequency match those listed on the power supply. The Mini Monitor is now powered, and the Micastat® laminate is now grounded.

10mm Park Snap and 10mm Operator Jack Adapter

The [19243](#) Mini Monitor includes an interchangeable 10mm park snap and 10mm banana jack adapter for operators who use wrist cords with 10mm terminations. Use the park snaps' knurled rims to unscrew the 4mm park snap from the monitor and install the 10mm park snap to the monitor. Plug the 10mm operator jack adapter into the monitor's operator jack.



Figure 7. Changing the park snap on the [19243](#) Mini Monitor

Operation

1. Fit the wristband snugly onto the wrist.
2. Snap the wrist cord to the wristband.
3. Plug the wrist cord into the operator jack. The green operator LED will illuminate. This indicates that the operator is properly grounded.
4. If this does not happen, examine the wrist cord for continuity or damage and the wristband to ensure that it fits securely. If you have dry skin, apply an approved dissipative hand lotion such as [Menda Reztore® ESD Hand Lotion](#).
5. When leaving the workstation, first touch the monitor's park snap. The monitor's audible alarm will disable for approximately 10 seconds. Use this time to disconnect the wrist cord from the wristband and attach it to the park snap without sounding a false alarm.
6. Upon returning to the workstation and disconnecting the wrist cord from the park snap, the monitor will provide approximately 10 seconds for the operator to reconnect the wrist cord to a worn wristband before sounding the monitor's alarm.



Figure 8. Using the Mini Monitor

Calibration

Frequency of recalibration should be based on the critical nature of those ESD sensitive items handled and the risk of failure for the ESD protective equipment and materials. In general, Desco recommends that calibration be performed annually.

Use the Desco [98221](#) Wave Distortion Monitor Verification Tester to perform periodic verification (once every 6-12 months) of the Mini Monitor. The verification tester can be used to check the test limits of the Mini Monitor without removing it from the workstation.

See [TB-3074](#) for more information.



Figure 9. Desco [98221](#) Wave Distortion Monitor Verification Tester

Specifications

Input Voltage and Frequency (External Adapter)	AC/DC Power Adapter Power Input: 100-240VAC, 50/60 Hz Power Output: 24VDC @ 150mA Cable Length: 5 ft. (1.5 m)
Operating Temperature	50 to 95°F (10 to 35°C)
Environmental Requirements	Indoor use only at altitudes less than 6500 ft. (2 km) Maximum relative humidity of 80% up to 85°F (30°C) decreasing linearly to 50% @ 85°F (30°C)
Dimensions	2.77" L x 2.08" W x .90" H (70 mm x 53 mm x 23 mm)
Weight	0.1 lbs. (0.05 kg)
Operator Test Range*	500 kilohms to 10 megohms impedance
Worksurface Test Limit**	500 megohms (±20%)
Operator Test Voltage	1.2V peak-to-peak @ 1.2µA, open circuit
Worksurface Test Voltage	5 to 7.5V, open circuit
Alarm Response Time	<50 ms
Country of Origin	United States of America

*This cannot be verified with standard DC test equipment. The continuous monitor is an impedance sensing device, and the limits are determined by the magnitude and angle of the impedance.

**The worksurface mat must have a conductive layer such as Dual Layer Rubber or Dissipative 3-Layer Vinyl with conductive buried layers. Desco workstation monitors are not recommended for use with homogeneous matting.

ANSI/ESD S20.20 requires the use of a surface resistance meter for periodic verification of a worksurface's resistance-to-ground (Rtg). Constant monitors may not be used as a substitute for this requirement.

Limited Warranty, Warranty Exclusions, Limit of Liability and RMA Request Instructions

See the Desco Warranty -

Desco.com/Limited-Warranty.aspx