

User Manual



Visit us at www.TestEquipmentDepot.com

Professional Dual-Laser Infrared Thermometer with 30:1 Distance-to-Sight Ratio, USB Output, Single Type K Input, and Temperature Alarm

with NIST-Traceable Calibration

Model 20250-07

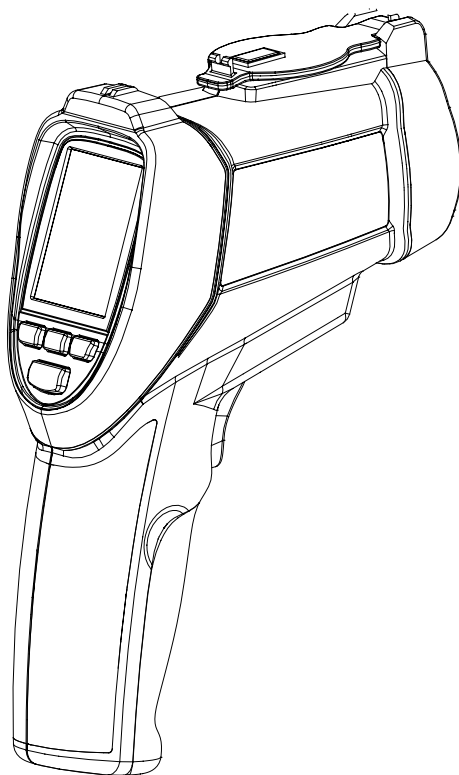

Introduction

The Digi-Sense Professional Dual-Laser Infrared Thermometer (Model 20250-07) with 30 to 1 distance-to-sight ratio offers fast response and high accuracy. This heavy-duty meter is ideal for a wide range of applications including food preparation, safety and fire inspection, plastic molding, marine, HVAC, and fleet maintenance. Advanced features include USB interface for data transmission, temperature alarm, adjustable emissivity, temperature differential, data Hold, Max/Min/Avg readings, and auto power-off. The meter also supports contact measurement through a type K thermocouple input. The instrument is fully tested and calibrated to NIST-traceable standards. Careful use of this meter will provide years of reliable service.

Unpacking

Check individual parts against the list of items below. If anything is missing or damaged, please contact your instrument supplier immediately.

1. Meter
2. One type K flexible probe
3. USB cable
4. Software
5. Tripod
6. Carrying case
7. One 9 V battery
8. User manual
9. NIST-traceable calibration report with data

Key Features

- 30:1 Distance-to-sight ratio
- 1.5% basic accuracy
- Dual laser sighting
- USB interface for transmission of data to PC
- Contact measurements via type K thermocouple input
- Precise noncontact IR measurements
- Rapid detection function
- Adjustable emissivity from 0.10 to 1.0
- User-selectable °C or °F units
- Automatic data Hold
- MAX/MIN/AVG temperature displays
- Temperature differential
- High and low alarms (audible)
- Automatic selection range and display resolution
- Trigger lock
- Backlight LCD
- Automatic power-off to conserve battery life

Meter Description

1. IR sensor
2. Laser pointer beam
3. Type K thermocouple input
4. USB computer interface
5. LCD
6. **Up ▲** button
7. **Backlight**  / **Laser** button
8. **Down ▼** button
9. **MODE** button
10. Lens cover with magnetic lock
11. Measurement trigger
12. Battery cover
13. Handle grip

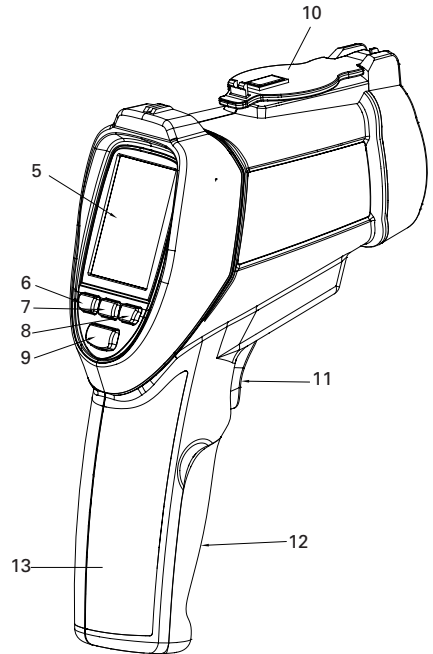
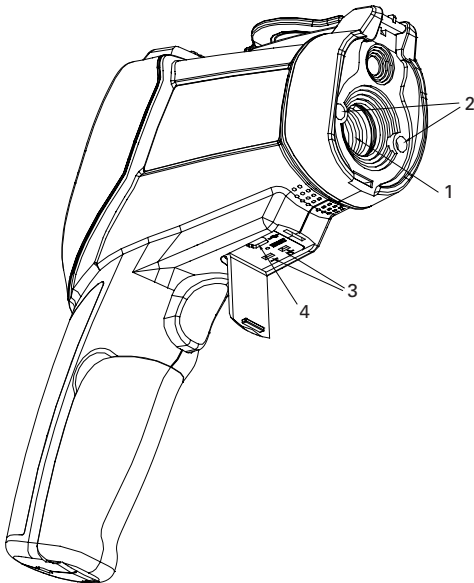

Display Layout

1. SCAN measuring indicator
2. Data HOLD icon
3. Laser pointer indicator
4. Trigger lock indicator
5. High alarm indicator
6. Low alarm indicator
7. MAX, MIN, AVG, and DIF icons
8. °C and °F temperature icons
9. USB icon (transmit data to PC)
10. Low-battery indicator
11. Emissivity or type K temperature readout
12. Type K thermocouple icon
13. Emissivity icon
14. Current temperature readout
15. Max, Min, Avg, or Dif temperature readout

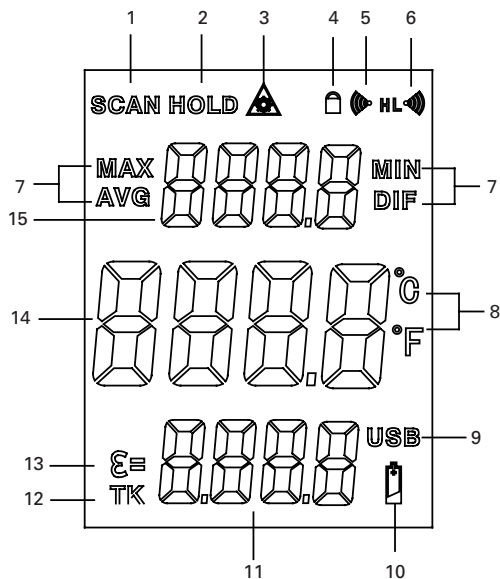

How it Works

Infrared thermometers measure the surface temperature of an object. The unit's optics sense emitted, reflected, and transmitted energy, which is collected and focused onto a detector. The unit's electronics translate the information into a temperature reading which is displayed on the unit. The laser is used for aiming purposes only.

Field of View

Make sure that the target is larger than the unit's spot size. The smaller the target, the closer you should be to it. When accuracy is critical, make sure the target is at least twice as large as the spot size.

Distance and Spot Size

As the distance (D) from the object increases, the spot size (S) of the area measured by the unit becomes larger.

Locating a Hot Spot

To find a hot spot, aim the thermometer outside the area of interest, then scan across with an up-and-down motion until you locate the hot spot.

Emissivity

Emissivity is a term used to describe the energy-emitting characteristics of materials. Most (90% of typical applications) organic materials and painted or oxidized surfaces have an emissivity of 0.95 (preset in the unit). Inaccurate readings will result from measuring shiny or polished metal surfaces. To compensate, cover the surface to be measured with black tape or flat black paint. Allow time for the tape to reach the same temperature as the material underneath it. Measure the temperature of the tape or painted surface. (Refer to table on facing page.)

Good Measuring Practices

Holding the meter by its handle, point the IR sensor toward the object whose temperature is to be measured. The meter automatically compensates for temperature deviations from ambient temperature. Keep in mind that it will take up to 30 minutes for the IR sensor to stabilize if going from ambient temperatures to a much higher (or lower) temperature measurement.

Reminders

- The unit is not recommended for measuring shiny or polished metal surfaces (stainless steel, aluminum, etc.). See **Emissivity** above.
- The unit cannot measure through transparent surfaces such as glass. It will measure the surface temperature of the glass instead.
- Steam, dust, smoke, etc. can prevent accurate measurement by obstructing the unit's optics.

Emissivity Values

Substance	Thermal emissivity	Substance	Thermal emissivity
Asphalt	0.90 to 0.98	Cloth (black)	0.98
Concrete	0.94	Human skin	0.98
Cement	0.96	Lather	0.75 to 0.80
Sand	0.90	Charcoal (powder)	0.96
Earth	0.92 to 0.96	Lacquer	0.80 to 0.95
Water	0.92 to 0.96	Lacquer (matte)	0.97
Ice	0.96 to 0.98	Rubber (black)	0.94
Snow	0.83	Plastic	0.85 to 0.95
Glass	0.90 to 0.95	Timber	0.90
Ceramic	0.90 to 0.94	Paper	0.70 to 0.94
Marble	0.94	Chromium oxides	0.81
Plaster	0.80 to 0.90	Copper oxides	0.78
Mortar	0.89 to 0.91	Iron oxides	0.78 to 0.82
Brick	0.93 to 0.96	Textiles	0.90

Setup and Operation

1. Hold the meter by its handle grip and point it toward the surface to be measured.
2. Pull and hold the trigger to turn the meter on and begin testing. The display will light if the battery is good. Replace the battery if the display does not light. Meter automatically powers down after 10 seconds once the trigger is released.
3. While measuring, the **SCAN** icon will appear in the upper left-hand corner of the LCD.
4. Release the trigger and the **HOLD** icon will appear at the top of the LCD, indicating that the reading is being held.
5. While in the **HOLD** mode, press the **MODE** button to access and set the Max/Min/Avg/Dif readings, emissivity (EMS) value, trigger lock (on/off), high alarm (on/off and set point), low alarm (on/off and set point), and temperature units (°C or °F). Each time you press the **MODE** button, you advance through each option. Refer to the flow chart on facing page to see the sequence of functions in the mode cycle.
 - a. **Emissivity (EMS)**. When the **Emissivity** icon is flashing, use the **Up ▲** and **Down ▼** buttons to adjust the value from 0.10 to 1. Then press the **MODE** button again to enter setting. **Note:** If the type K thermocouple is connected, you cannot adjust emissivity.
 - b. **Trigger Lock**. Use for continuous monitoring of temperatures. When the **Lock** icon is flashing, use the **Up ▲** or **Down ▼** button to turn "on". Then press the **MODE** button again to enter setting. Once you press the measurement trigger, the **Lock** icon is shown, confirming the lock measurement mode. The meter will continuously display the temperature until the measurement trigger is pressed again.
 - c. **High Alarm**. When the **High alarm** icon is flashing, use the **Up ▲** or **Down ▼** button to turn "on". Then press the **MODE** button again to enter setting. The **High alarm** icon will still be flashing, allowing you to set the alarm trigger temperature set point using the **Up ▲** and **Down ▼** buttons. Press **MODE** button again to enter setting.
 - d. **Low Alarm**. When the **Low alarm** icon is flashing, use the **Up ▲** or **Down ▼** button to turn "on". Then press the **MODE** button again to enter setting. The **Low alarm** icon will still be flashing, allowing you to set the alarm trigger temperature set point using the **Up ▲** and **Down ▼** buttons. Press **MODE** button again to enter setting.
6. **Max, Min, Avg, Dif Readings**. While measuring, pressing the **MODE** button will allow you to toggle between maximum, minimum, average, and differential readings.
7. **Laser Pointer and Backlight Functions**. Press the **Backlight/Laser** button to turn the laser and backlight functions on and off at any stage.

8. **USB Function.** Meter will transmit the IR and T/C measurement data to a PC via USB interface. While in measurement mode, press and hold the **Backlight/Laser** button until the **USB** icon appears in the lower corner of the LCD, indicating the function is turned on. Press and hold the **Backlight/Laser** button again to turn off the **USB** function; the USB icon will then disappear from the LCD. **Note:** Install software according to steps at bottom of page.

Setup MODE Flow Chart

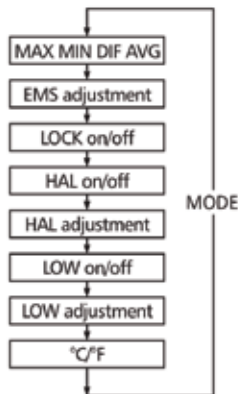

Recording / Data Transmission Operation (Software)

1. First install the software on PC following the setup wizard. Once software is successfully installed, the data transmission icon shortcut will be automatically placed on your PC desktop.
2. Connect the meter to your PC via the supplied USB cable.
3. Power the meter on.
4. Open the installed Data Transmission Software by double-clicking on the icon on your PC desktop.
5. The software will automatically detect the meter and start to download the data to your PC. **Note:** Meter must be in scanning mode for the data to transfer to your PC. The software screen will display the data being downloaded from the meter. The data results will be displayed graphically and numerically for each reading taken.
6. To save the measurement data to your PC, select "File" icon from the menu bar and save data to desired location on your PC. **Note:** Data will be saved in an Excel® format that will include all summary information as captured on the "Data Summary" tab.
7. To print recorded data, simply select the "print" icon on the menu bar.
8. On the menu bar, select HELP to read detailed information on the capabilities of this software.

Specifications

IR temperature range	-58 to 3002°F (-50 to 1650°C)
T/C temperature range	-58 to 2498°F (-50 to 1370°C)
Resolution	0.1°F/C below 1000°, 1°F/C above 1000°
IR accuracy	From -58 to 68°F (-50 to 20°C): ±5.4°F (3°C) From 68 to 752°F (20 to 400°C): ±1.0% ± 1.8°F (1°C) From 752 to 1472°F (400 to 800°C): ±1.5% ± 3.6°F (2.0°C) From 1472 to 3002°F (800 to 1650°C): ±2.5%
T/C accuracy	From -58 to 1832°F (-50 to 1000°C): ±1.5% of reading ± 5°F (±3°C) From 1832 to 2498°F (1000 to 1370°C): ±1.5% of reading ± 3.6°F (±2°C)
IR response time	150 ms
Emissivity	Adjustable from 0.10 to 1.0
Distance-to-sight ratio (field of view)	D/S = approximately 30:1 ratio (D = distance, S = spot)
Laser	Dual Class 2 (II) lasers
Spectral range	8 to 14 μm
Out-of-range indication	LCD will show "----"
Operating temperature	32 to 122°F (0 to 50°C)
Storage temperature	14 to 140°F (-10 to 60°C)
Weight	17.4 oz (494 g)
Dimensions	7½" x 6" x 2¼" (18.9 x 15.2 x 5.7 cm)
Power	One 9 V battery

Field of View

The meter's field of view is 30:1, meaning that if the meter is 30 inches from the target, the diameter of the object under test must be at least 1 inch. Other distances are shown in the diagram at right. Make sure that the target is larger than the meter's spot size. The smaller the target, the closer you should be to it. When accuracy is critical, make sure the target is at least twice as large as the spot size. As the distance (D) from the object increases, the spot size (S) of the area measured by the meter becomes large. The relationship between distance and spot size is shown in diagram. The focal point is 36" (914 mm). The spot sizes indicate 90% encircled energy.

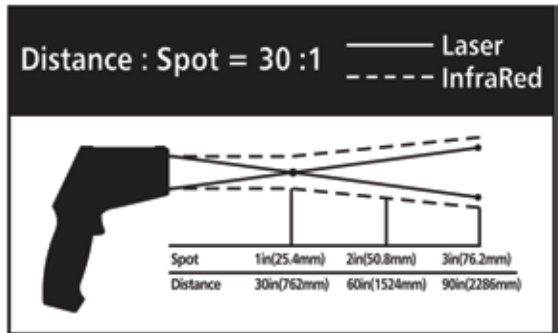

Safety

- Use extreme caution when the laser beam is turned on.
- Do not let the laser beam enter your eye, another person's eye or the eye of an animal.
- Be careful not to let the laser beam on a reflective surface strike your eye.
- Do not allow the laser light beam to impinge on any gas which can explode.



Maintenance, Recalibration, and Repair

Cleaning and Storage

- The meter should be cleaned with a damp cloth and mild detergent when necessary. Do not use solvents or abrasives.
- Store the meter in an area with moderate temperature and humidity (refer to the operating and storage temperatures on facing page).

Battery Replacement

If the battery power is insufficient, the **Low-battery** icon will appear on the LCD. Open the battery cover and replace the 9 V battery. Securely close the cover.

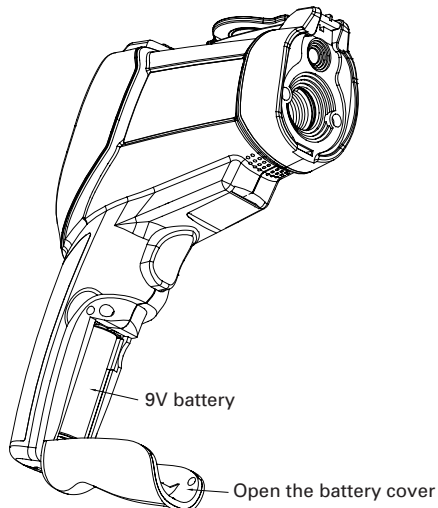

Maintenance, Recalibration, and Repair (continued)

It is recommended that Digi-Sense products are calibrated annually to ensure proper function and accurate measurements; however, your quality system or regulatory body may require more frequent calibrations. To schedule your recalibration, please contact InnoCal, an ISO 17025 calibration laboratory accredited by A2LA.



Phone: 1-866-INNOCAL (1-866-466-6225)

Fax: 1-847-327-2993

E-mail: sales@innocalsolutions.com

Web: InnoCalSolutions.com

For Product and Ordering Information, Contact:



99 Washington Street
Melrose, MA 02176
Phone 781-665-1400
Toll Free 1-800-517-8431

