



**120 ° Adjustable
Illumination**



**6 ft Power Cord
w/ 100V Plug**

High Brightness 14 Watts x 2 LEDs	Glass Diffuser Provides even light distribution	IP67 Rated Sealed to keep out fluids, chips & shavings	Angle Light 0° - 120° Adjustable mounting bracket
--	--	--	---

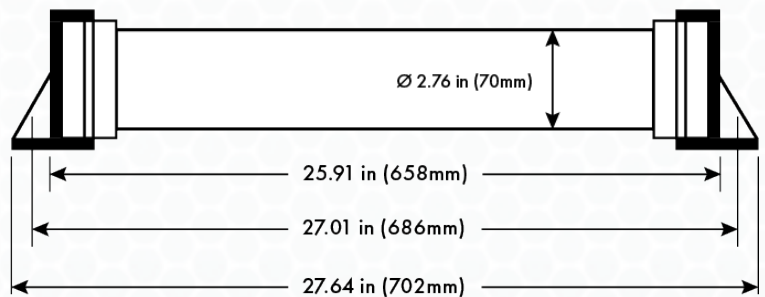
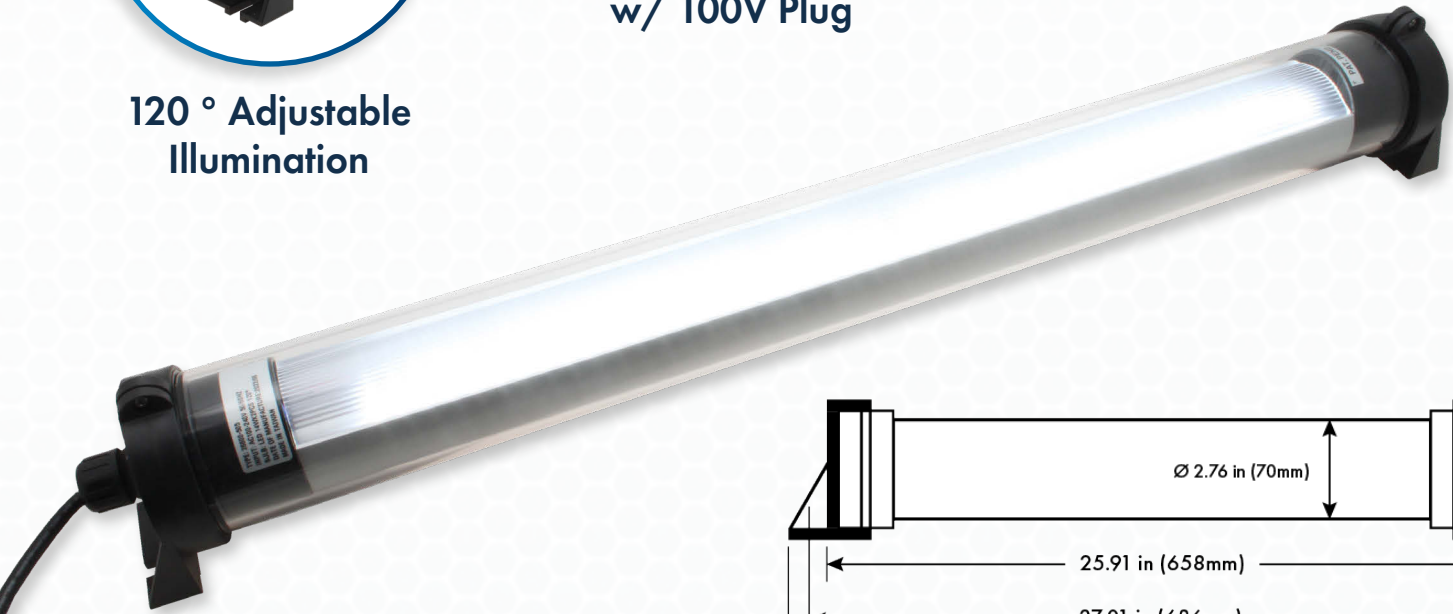

Machine Light

**Tubular LED Machine Light 2 x 14 Watt 26 in (658mm)
with Glass Diffuser**

Aven's LED machine lights are designed to provide even, ultra high brightness and a wide illumination angle for use with machining centers, semiconductor manufacturing equipment, workshops, clean rooms etc. This Tubular LED Machine Light is 26 in (658mm) in length with a diameter of 2.76 in (70mm). The LED lights provide 40,000 hours of life. The glass diffuser lens provides even light distribution. The machine light is IP67 rated and comes with a mounting bracket with hardware and a 6ft cable with 110V plug.

Key Features

- Long life LEDs (40,000 hours)
- Illuminance: 530 lux at 55 inches (1.4 meters)
- Wide illumination angle
- IP67 rated
- Sealed to keep out fluids, chips and shavings
- Glass diffuser lens
- Built-in Ballast

Machine Light <i>Tubular LED Machine Light 2 x 14 Watt 26 in (658mm) with Glass Diffuser Lens</i>	
Item #	26600-505G
Input Voltage	AC100-240V 50/60 HZ
LED Watts	14 watts x 2
Illuminance	530 lux at 55 in (1.4meters)
Color Temperature	5700K
Illumination Angle	0° - 120° Degrees
Rating	IP67
Lens Type	Glass
Cable Length	6 ft with 110V Plug
Operating Temperature Range	-30°C to +40°C -22°F to +104°F
Package Contents	<ul style="list-style-type: none"> • Machine Light • Mounting Bracket w/ Hardware • 6ft cable w/ 110V plug