User's Manual

2786 Decade Resistance Box

Test Equipment Depot - 800.517.8431 - 99 Washington Street Melrose, MA 02176 - TestEquipmentDepot.com

Introduction

Thank you for purchasing the 2786 Decade Resistance Box. This User's manual contains useful information regarding the instrument's functions and operating procedures, as well as precautions that should be observed during use. Before using this product, thoroughly read this manual to understand how to use it properly.

Keep this manual in a safe place for quick reference in the event that a question arises.

Contact information of Yokogawa offices worldwide is provided on the following sheet.

PIM 113-01Z2 Inquiries List of worldwide contacts

Notes

- The information contained in this manual is subject to change without notice. Furthermore, the actual display items may differ slightly from the ones appearing in this manual.
- Every effort has been made to ensure the information contained herein is accurate. However, should any concerns, errors, or emissions come to your attention, or if you have any comments, please contact us.
- Copying or reproduction of any or all of the content of this manual without Yokogawa's permission is strictly prohibited.

Cautionary Notes for Safe Use of the Product

When operating the instrument, be sure to observe the cautionary notes given below to ensure correct and safe use of the instrument. If you use the instrument in any way other than as instructed in this manual, the instrument's protective measures may be impaired. This manual is an essential part of the product; keep it a safe place for future reference. YOKOGAWA is by no means liable for any damage resulting from use of the instrument in contradiction to these cautionary notes.

■ The following safety symbols are used on the instrument and in the manual:



Danger! Handle with Care.

This symbol indicates that the operator must refer to an explanation in the User's Manual or Service Manual in order to avoid risk of injury or loss of life of personnel or damage to the instrument.

WARNING

Indicates a hazard that may result in the loss of life or serious injury of the user unless the described instruction is abided by.

CAUTION

Indicates a hazard that may result in an injury to the user and/or physical damage to the product or other equipment unless the described instruction is abided by.

- **Since mishandling the instrument can result in an accident that may lead to injury or death of the operator, such as an electric shock, be sure to observe the following instructions.**

 **WARNING**

● **Measurement**

- Always maintain the instrument within the limits for allowable current, voltage and power, during operation.
If there is more than one limit for any of these parameters, the lowest limit takes precedence.
- Only operate the instrument on an input-to-ground supply voltage of no greater than 250 V.
- The terminals and internal circuitry may become electrified to high voltages and extremely hot depending on the instrument's condition of use.
Do not touch these parts.

● **Grounding**

- To avoid electric shock, be sure to apply protective grounding to the grounding terminal.

● **Protective Measure**

- If a crack appears in the instrument after it has been accidentally dropped or bumped, the safety-purpose insulation may be damaged.
By all means do not use the instrument, but ask the manufacturer for repair.
-
-

 **WARNING**

● **Operating Environment**

- Do not operate the instrument in a flammable or explosive gas atmosphere.
- Do not operate the instrument if there is any condensation on it.

● **Do Not Remove the Casing or Disassemble**

- Only Yokogawa service personnel are authorized to remove the casing or disassemble or modify the instrument.
Do not attempt to repair the instrument yourself, as doing so is extremely dangerous.
(If you are rack-mounting the instrument, use it correctly according to the handling procedure.)
-
-

CONTENTS

Introduction	i
Cautionary Notes for Safe Use of the Product	ii
1. GENERAL	1
1.1 Description	1
1.2 Features	1
1.3 Specification	2
2. NAMES AND FUNCTIONS OF COMPONENTS	3
3. OPERATION	5
4. MAINTENANCE	6
5. CIRCUIT DIAGRAM	7
Disposing the Product	10

1. GENERAL

1.1 Description

The 2786 Decade Resistance Boxes are stable variable resistors with 6 dials which can be set accurately and quickly. They are used at DC/low frequencies. These resistance boxes can be used in combination with voltage or current generators for adjusting voltage or current. They can also be used as dummy load resistances or in an arm of an AC bridge, and are indispensable for various experiments and studies and as testing facilities for production lines. Two types are available as follows.

Model	Description
278610	0.1 to 111, 111 Ω (6 dials)
278620	1 to 1111, 110 Ω (6 dials)

1.2 Features

(1) Low Temperature coefficient, little resistance shift due to aging

These resistance elements have temperature coefficient of less than ± 10 ppm/ $^{\circ}\text{C}$ and excellent long-term stability.

(2) Small Residual Resistance

Errors due to switch contact resistance, wiring resistance and the fluctuation of contact resistance due to dial position, are extremely small. Yokogawa's Decade Resistance Boxes are the product of years of experience.

(3) Metal Case

Resistance elements are accommodated in a metal case to minimize the effect of external influences electrical and magnetic fields, short term temperature variations, physical damage or contamination.

(4) Compact and light weight

These instruments are compact, lightweight and portable.

(5) Rack-mounted type

The 2786 can be rack-mounted, if the case is removed.

1.3 Specifications

Number of Dials:	6
Resistance Range:	278610; 0.1 to 111,111 Ω 278620; 1 to 1111,110 Ω
Residual Resistance:	less than 23 mΩ
Rated Input Power:	0.3 W/step, within 3 W in total avoid applying voltages greater than maximum rated voltage to the terminals.
Maximum Permissible Input Power:	0.5 W/step, within 5 W in total avoid applying voltages greater than maximum rated voltage to the terminals.
Operating Temperature Range:	0 to 40°C, Humidity 25 to 85%RH
Storage Temperature Range:	-10 to 50°C
Maximum Circuit Voltage:	250 VDC
Dielectric Strength:	1500 VAC for one minute
Insulation Resistance:	More than 500 MΩ at 500 VDC
Dimensions:	Approx. 116 × 497 × 140 mm
Weight:	Approx. 3.5 kg
Accessory:	User's Manual 1 copy

Accuracy and Temperature coefficient:

Dial Step	Accuracy*1	Temperature Coefficient*2	
		α_{23} ($\times 10^{-6}/^{\circ}\text{C}$)	β ($\times 10^{-6}/^{\circ}\text{C}^2$)
0.1 Ω	±2%	±250	-0.4 to -0.8
1 Ω	±0.5%	±100	-0.4 to -0.8
10 Ω	±0.1%	±20	-0.4 to -0.8
100 Ω	±0.05%	±10	-0.4 to -0.8
1 kΩ	±0.05%	±10	-0.4 to -0.8
10 kΩ	±0.1%	±50	±0.1
100 kΩ	±0.1%	±50	±0.1

- *1 • At a temperature of 23±3°C, humidity of 45 to 75% and input power less than 0.1 W.
- The resistance values do not include the residual resistance.
The effects increase for small resistance settings.
- *2 Variation of resistance with temperature change is given by the following equation

$$R_t = R_{23} \{1 + \alpha_{23}(t - 23) + \beta(t - 23)^2\}$$

Where R_t : Resistance value at $t^{\circ}\text{C}$

R_{23} : Resistance value at 23°C

2. NAMES AND FUNCTIONS OF COMPONENTS

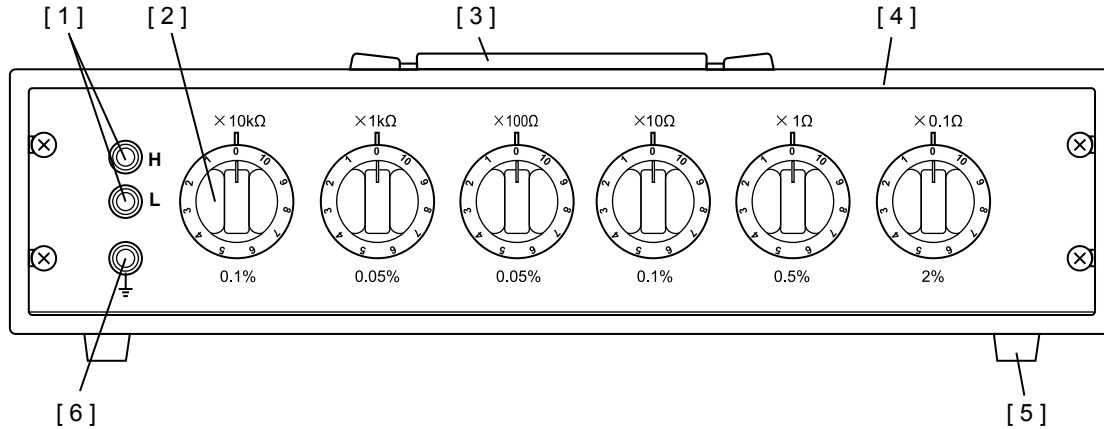

Figure 2.1 278610

[1] Resistance Terminals:

Addition of the values indicated on the dials gives the resistance between the terminals.

[2] Resistance Setting Decade Dials:

Set the desired resistance value for each dial.

[3] Carrying Handle:

[4] Metal Case:

[5] Rubber Feet:

[6] Earth Terminal:

This earth (ground) terminal is connected to the front panel.

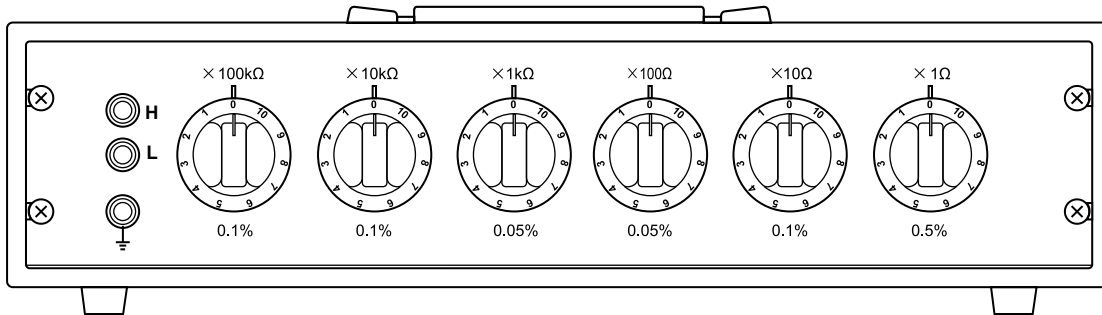

Figure 2.2 278620

3. OPERATION

- (1) Addition of the values indicated on the dials gives the resistance between the terminals.

That is, to obtain a resistance of 12345.6 Ω with the 278610, $\times 10$ k Ω , $\times 1$ k Ω , $\times 100$ Ω , $\times 10$ Ω , $\times 1$ Ω , and $\times 0.1$ Ω dials should be set to 1, 2, 3, 4, 5, and 6 respectively.

- (2) The percentage error and maximum permissible input current for each resistance element-corresponding to a power dissipation of 0.3 W are shown in Table 3.1. The percentage error is also shown on the instrument front panel.

Be careful not to exceed the maximum permissible input current or voltage ratings, or the resistance elements may shift in value.

When two or more dials are used simultaneously, the allowable maximum current is that of the higher resistance value dial.

- (3) Of the two resistance terminals, the one which is closer to the earth terminal $\underline{\underline{\text{L}}}$ is the low resistance (L) terminal. Consequently, when the instrument is used for an unbalanced circuit, this terminal should be connected to lower potential side of the circuit.

Dial Step	Accuracy	Operating Current	Maximum Allowable Current
0.1 Ω	$\pm 2\%$	1.7 A	2.2 A
1 Ω	$\pm 0.5\%$	550 mA	710 mA
10 Ω	$\pm 0.1\%$	170 mA	220 mA
100 Ω	$\pm 0.05\%$	55 mA	71 mA
1 k Ω	$\pm 0.05\%$	17 mA	22 mA
10 k Ω	$\pm 0.1\%$	5.5 mA	7.1 mA (10 k Ω to 30 k Ω) 250 V (40 k Ω to 100 k Ω)
100 k Ω	$\pm 0.1\%$	250 V (200 k Ω to 1 M Ω) 1.7 mA (100 k Ω)	250 V

Table 3.1

- (4) Dielectric strength between instrument terminals and case: withstands 1500 VAC for one minute, and insulation resistance between instrument terminals and case is more than 500 M Ω at 500 VDC. However these conditions depend on ambient temperature and humidity. Observe maximum rated voltage.

- (5) As enclosed type dial switches are employed in the instrument, switch contacts resistance is stable even in dusty areas or where corrosive gases, etc. However, when the instrument has not been used for sometimes, turn the dials several times before use.
- (6) If electrical or mechanical shocks appear to have damaged the instrument, check, its resistance. The 2768 Precision Wheatstone Bridge is suitable.
- (7) The 2786 can be rack-mounted. When rack-mounted, the case is removed, so place a simple cover to protect components, such as resistance elements and switches.

4. MAINTENANCE

To insure accurate measurement it is essential to maintain the instrument in good condition.

Therefore, avoid the following environments:

- Where humidity is high.
- Where the instrument is exposed to direct sunlight, or high temperature.
- Where the instrument is next to a heat source.
- Where the instrument will be subjected to severe vibration.
- Where the atmosphere is salty, contains corrosive gas, dust or dirt.

Calibration

Recommended calibration period: 1 year

Periodic calibration is recommended to maintain the accuracy of the instrument.

5. CIRCUIT DIAGRAM

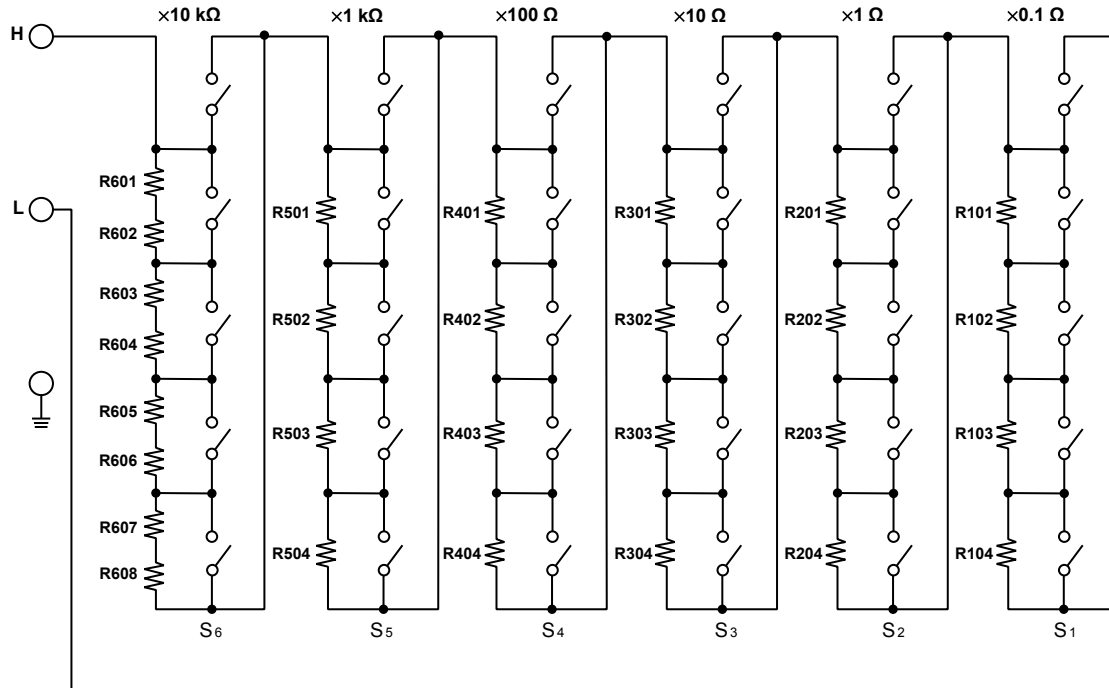

Figure 5.1 278610

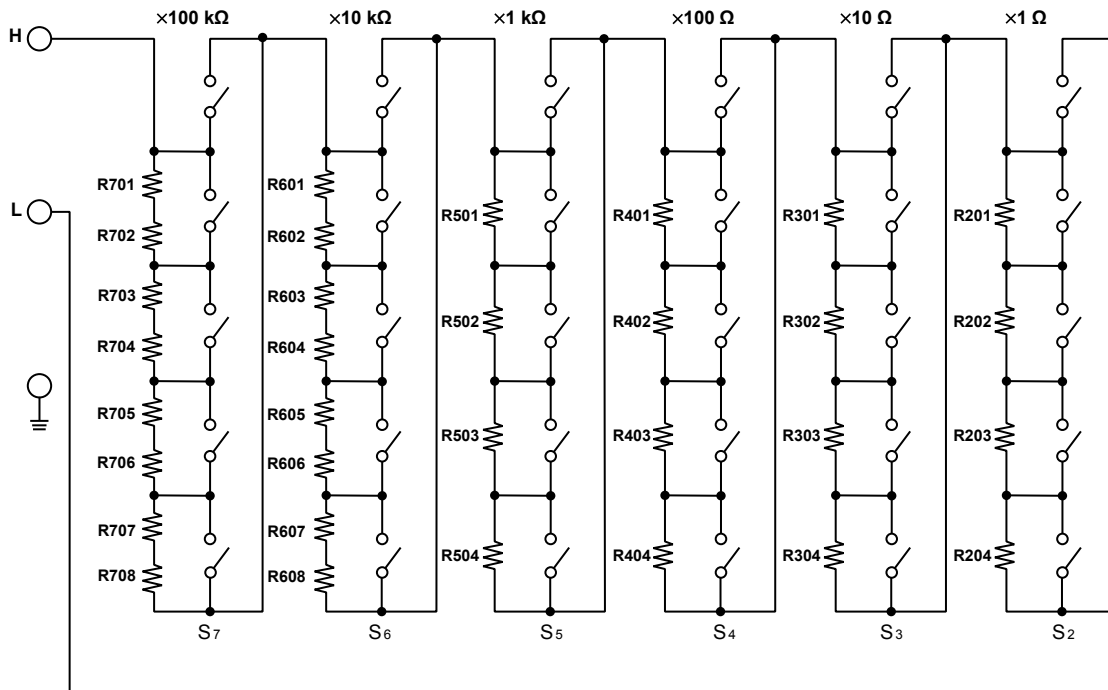

Figure 5.2 278620

Reference Designation	Description	
R101	0.1 Ω	WIRE-WOUND
R102	0.2 Ω	
R103	0.2 Ω	
R104	0.5 Ω	
R201	1 Ω	
R202	2 Ω	
R203	2 Ω	
R204	5 Ω	
R301	10 Ω	
R302	20 Ω	
R303	20 Ω	
R304	50 Ω	
R401	100 Ω	
R402	200 Ω	
R403	200 Ω	
R404	500 Ω	
R501	1 k Ω	
R502	2 k Ω	
R503	2 k Ω	
R504	5 k Ω	

Reference Designation	Description	
R601	5 k Ω	MET-FLM
R602	5 k Ω	
R603	10 k Ω	
R604	10 k Ω	
R605	10 k Ω	
R606	10 k Ω	
R607	25 k Ω	
R608	25 k Ω	
R701	50 k Ω	
R702	50 k Ω	
R703	100 k Ω	
R704	100 k Ω	
R705	100 k Ω	
R706	100 k Ω	
R707	250 k Ω	
R708	250 k Ω	

Disposing the Product

Waste Electrical and Electronic Equipment (WEEE), Directive

(This directive is valid only in the EU.)

This product complies with the WEEE directive marking requirement.

This marking indicates that you must not discard this electrical/electronic product in domestic household waste.

Product Category

With reference to the equipment types in the WEEE directive, this product is classified as a "Monitoring and control instruments" product.

When disposing products in the EU, contact your local Yokogawa Europe B.V. office.

Do not dispose in domestic household waste.



Printed in Japan