

34065 OIL INJECTOR FOR SERVICING R-134A A/C SYSTEMS

⚠ WARNING ⚠



Unplug the unit before beginning service work. Incorrect use or connections can cause electrical shock.



Wear eye protection when working with refrigerants. Contact with refrigerant can cause eye injury.



Use extreme caution when disconnecting hoses. Pressurized refrigerant may be present in hoses. Point hoses away from you and anyone nearby.



Use only PAG oil in the oil injector, and then only to service vehicles with R-134a A/C systems. Use of other oils, or use with other types of A/C systems, will result in system failure.



Use only with refrigerant type R-134a. Cross-contamination with other refrigerant types will cause severe damage to the A/C system, and to service tools and equipment. Do not mix refrigerant types through a system or in the same container.



Use only with refrigerant type R-134a. Cross-contamination with other refrigerant types will cause severe damage to the A/C system, and to service tools and equipment. Do not mix refrigerant types through a system or in the same container.

Avoid breathing A/C refrigerant and lubricant vapor or mist. Exposure may irritate eyes, nose, and throat. To remove R-134a from the A/C system, use service equipment certified to meet the requirements of SAE J2210 (R-134a recycling equipment). If accidental system discharge occurs, ventilate the work area before resuming service. Additional health and safety information may be obtained from refrigerant and lubricant manufacturers.

Do not pressure test or leak test HFC-134a service equipment or vehicle A/C systems using compressed air. Some mixtures of air/HFC-134a have been shown to be combustible at elevated pressures. These mixtures are potentially dangerous and may result in fire or explosion causing injury or property damage. Additional health and safety information may be obtained from refrigerant and lubricant manufacturers.

Do not open valve to pressurized system. The No. 34065 Oil Injector is not designed for use with high pressure.

The oil injector is designed for use with a manifold gauge set. Oil is charged into the system through the blue low-side hose while the system is in a vacuum.

Note: It is important to keep the oil level above the end of the dip tube in the bottle (at a minimum of one ounce) to prevent air from entering the system.

HOOK-UP AND OPERATION

1. Recover used refrigerant from the system following the manufacturer's specifications.
2. Open both manifold gauge valves, and verify there is no pressure present on both gauges.
3. While the system is in a vacuum, close the manifold's red high-side and blue low-side valves.

For Manifold: Attach the oil injector to the refrigerant port of the manifold using a charging hose.

For Charging Stations: The oil injector should already be installed onto the manifold. See "Installation Instructions" on the next page.

4. Verify there is sufficient oil in the bottle. If not, unthread the bottle from the cap, add oil to the bottle, and thread the bottle tightly onto the cap.
5. Open the manifold's blue low-side valve.
6. Note the oil level in the injector bottle; then open the oil injector valve. Watch the calibrations on the bottle, allowing the correct amount of oil to be charged into the system. Close the oil injector valve to stop the oil charge (but do not go below one ounce).

For Manifold: Close the low-side manifold valve, and verify all valves are closed. Disconnect the oil injector from the manifold, and continue recharging or proceed with the next service operation.

For Charging Station: Close the oil injector valve; then continue recharging as needed, or proceed with the next service operation.



99 Washington Street
Melrose, MA 02176
Phone 781-665-1400
Toll Free 1-800-517-8431

Visit us at www.TestEquipmentDepot.com

Continued

INSTALLATION INSTRUCTIONS

Follow these steps to install No. 34065 Oil Injector on the 34100 Smart Cart or 34050 Manual Charging Station:

1. Turn off the MAIN POWER switch, and unplug the station from the power source. The station **must be disconnected** from the vehicle.
2. Remove the $\frac{1}{8}$ " hex pipe from the left end of the manifold, and install the fitting adapter included with the oil injector.
3. Attach No. 34065 to the adapter. The station is ready for use.

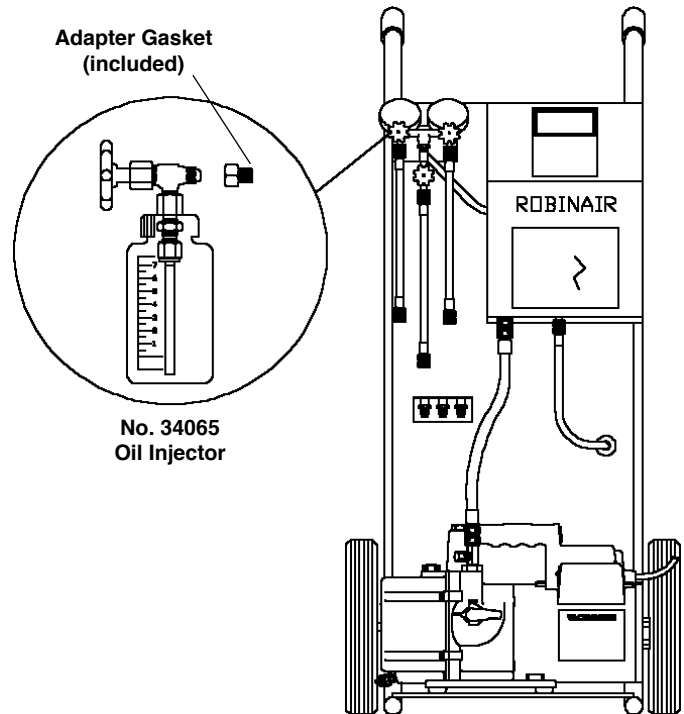

Because of ongoing product improvements, we reserve the right to change design, specifications, and materials without notice.

ROBINAIR®

**Test Equipment
Depot**
1-800-517-8431

99 Washington Street
Melrose, MA 02176
Phone 781-665-1400
Toll Free 1-800-517-8431

 Visit us at www.TestEquipmentDepot.com