

Hydraulic Pipe Bender



⚠ WARNING!

Read this Operator's Manual carefully before using this tool. Failure to understand and follow the contents of this manual may result in electrical shock, fire and/or serious personal injury.





Safety Symbols

In this operator's manual and on the product, safety symbols and signal words are used to communicate important safety information. This section is provided to improve understanding of these signal words and symbols.

 This is the safety alert symbol. It is used to alert you to potential personal injury hazards. Obey all safety messages that follow this symbol to avoid possible injury or death.

 **DANGER** DANGER indicates a hazardous situation which, if not avoided, will result in death or serious injury.

 **WARNING** WARNING indicates a hazardous situation which, if not avoided, could result in death or serious injury.

 **CAUTION** CAUTION indicates a hazardous situation which, if not avoided, could result in minor or moderate injury.

NOTICE NOTICE indicates information that relates to the protection of property.



This symbol means read the operator's manual carefully before using the equipment. The operator's manual contains important information on the safe and proper operation of the equipment.



This symbol means always wear safety glasses with side shields or goggles when handling or using this equipment to reduce the risk of eye injury.



This symbol indicates the risk of hands, fingers or other body parts being crushed.



This symbol indicates the risk the electrical shock.



This symbol indicates the risk of machine tipping, causing striking or crushing injuries.

General Safety Rules*

WARNING

Read all safety warnings and instructions. Failure to follow the warnings and instructions may result in electric shock, fire and/or serious injury.

SAVE ALL WARNINGS AND INSTRUCTIONS FOR FUTURE REFERENCE!

The term "power tool" in the warnings refers to your mains-operated (corded) power tool or battery-operated (cordless) power tool.

Work Area Safety

- **Keep your work area clean and well lit.** Cluttered or dark areas invite accidents.
- **Do not operate power tools in explosive atmospheres, such as in the presence of flammable liquids, gases, or dust.** Power tools create sparks which may ignite the dust or fumes.
- **Keep children and by-standers away while operating a power tool.** Distractions can cause you to lose control.

Electrical Safety

- **Power tool plugs must match the outlet. Never**

modify the plug in any way. Do not use any adapter plugs with earthed (grounded) power tools. Unmodified plugs and matching outlets will reduce risk of electric shock.

- **Avoid body contact with earthed or grounded surfaces such as pipes, radiators, ranges and refrigerators.** There is an increased risk of electrical shock if your body is earthed or grounded.
- **Do not expose power tools to rain or wet conditions.** Water entering a power tool will increase the risk of electrical shock.
- **Do not abuse the cord. Never use the cord for carrying, pulling or unplugging the power tool. Keep cord away from heat, oil, sharp edges or moving parts.** Damaged or entangled cords increase the risk of electric shock.
- **When operating a power tool outdoors, use an extension cord suitable for outdoor use.** Use of a cord suitable for outdoor use reduces the risk of electric shock.
- **If operating a power tool in a damp location is unavoidable, use a ground fault circuit interrupter (GFCI) protected supply.** Use of a GFCI reduces the risk of electric shock.

* The text used in the General Safety Rules section of this manual is verbatim, as required, from the applicable CSA 745/UL 45 standard. This section contains general safety practices for many different types of power tools. Not every precaution applies to every tool, and some do not apply to this tool.

Personal Safety

- **Stay alert, watch what you are doing and use common sense when operating a power tool. Do not use a power tool while you are tired or under the influence of drugs, alcohol, or medication.** A moment of inattention while operating power tools may result in serious personal injury.
- **Use personal protective equipment. Always wear eye protection.** Protective equipment such as dust mask, non-skid safety shoes, hard hat, or hearing protection used for appropriate conditions will reduce personal injuries.
- **Prevent unintentional starting. Ensure the switch is in the off-position before connecting to power source and/or battery pack, picking up or carrying the tool.** Carrying power tools with your finger on the switch or energizing power tools that have the switch on invites accidents.
- **Remove any adjusting key or wrench before turning the power tool ON.** A wrench or a key left attached to a rotating part of the power tool may result in personal injury.
- **Do not overreach. Keep proper footing and balance at all times.** This enables better control of the power tool in unexpected situations.
- **Dress properly. Do not wear loose clothing or jewelry. Keep your hair, clothing, and gloves away from moving parts.** Loose clothes, jewelry, or long hair can be caught in moving parts.
- **If devices are provided for the connection of dust extraction and collection facilities, ensure these are connected and properly used.** Use of dust collection can reduce dust-related hazards.

Power Tool Use And Care

- **Do not force power tool. Use the correct power tool for your application.** The correct power tool will do the job better and safer at the rate for which it is designed.
- **Do not use power tool if the switch does not turn it ON and OFF.** Any power tool that cannot be controlled with the switch is dangerous and must be repaired.
- **Disconnect the plug from the power source and/or the battery pack from the power tool before making any adjustments, changing accessories, or storing power tools.** Such preventive safety measures reduce the risk of starting the power tool accidentally.
- **Store idle power tools out of the reach of children and do not allow persons unfamiliar with the power tool or these instructions to operate the power tool.** Power tools are dangerous in the hands of untrained users.
- **Maintain power tools. Check for misalignment or binding of moving parts, breakage of parts and any other condition that may affect the power tool's operation. If damaged, have the power tool repaired before use.** Many accidents are caused by poorly maintained power tools.
- **Keep cutting tools sharp and clean.** Properly maintained cutting tools with sharp cutting edges are less likely to bind and are easier to control.
- **Use the power tool, accessories and tool bits etc. in accordance with these instructions, taking into account the working conditions and the work to be performed.** Use of the power tool for operations different from those intended could result in a hazardous situation.

Service

- **Have your power tool serviced by a qualified repair person using only identical replacement parts.** This will ensure that the safety of the power tool is maintained.

Specific Safety Information

⚠ WARNING

This section contains important safety information that is specific to this tool.

Read these precautions carefully before using the RIDGID® Hydraulic Pipe Benders to reduce the risk of crushing injuries, electric shock or other serious personal injury.

SAVE THESE INSTRUCTIONS!

Keep this manual with the hydraulic bender for use by the operator.

Hydraulic Pipe Bender Safety

- **Keep your fingers and hands away from the bending attachments and work piece during bending.** Your fingers, hands and other body parts can be caught, crushed, fractured or amputated if they become entangled in the bender or between these components and any other object.
- **Properly support the tool and pipe.** This will help to prevent the tipping of the pipe and equipment.





- **Pipe moves during bending and can cause striking or crushing injuries.** Be sure there is adequate clearance around the pipe before bending.
- **Hydraulic benders use high pressure fluid to generate large forces. High pressure fluid can penetrate skin. Large forces can break and throw parts, causing serious injury.** Stand clear of the unit during use and always wear appropriate protective equipment, including eye protection.
- **One person must control the work process and machine operation. Only the operator should be in the work area when the machine is operating.** This helps reduce the risk of injury.
- **Read and understand this manual, and the warnings and instructions for all equipment being used with this tool before operating.** Failure to follow all warnings and instructions may result in property damage and/or serious injury
- **Use the Hydraulic Pipe Bender only with RIDGID Hydraulic Pipe Bender attachments as directed in these instructions.** Other uses or modifying the Hydraulic Pipe Benders may damage the tool, the attachments or cause personal injury.

The EC Declaration of Conformity (890-011-320.10) will accompany this manual as a separate booklet when required.

- BS 1387 Medium and Heavy Series
- GB/3091 (ISO 559) Medium and Heavy Series

Pipe with thicker walls and/or high hardness (over 75 HRb)/strength (over 66 ksi/455 MPa Tensile) may not be able to be bent. Pipe with comparable outside diameter and wall thickness to the pipes listed may be able to be bent depending on pipe material characteristics. Pipe with thinner walls can be bent but may experience issues with kinking or buckling in the bend area.

Icons

-  Do not dispose of electrical equipment with household waste
-  Power ON
-  Power OFF
-  Fill Port
-  Weight

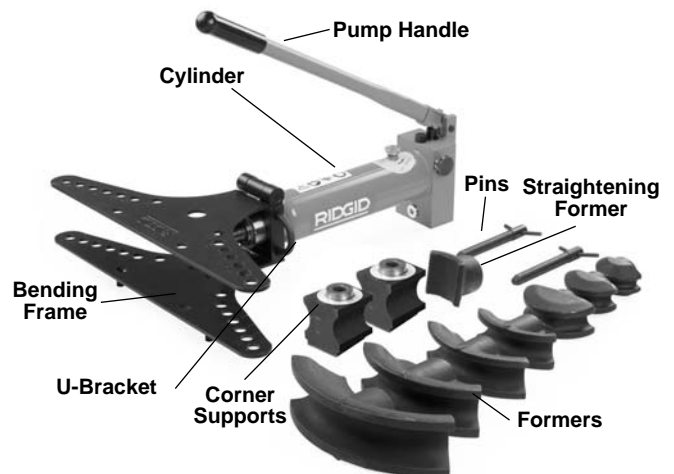

Figure 1 – Hydraulic Pipe Bender 2" and 3" Manual Unit

Description And Specifications

Description

RIDGID® Hydraulic Pipe Benders allow precision cold bending of metallic pipe from 1/4" to 3" (depending on the unit). The tip-up wing configuration of the RIDGID Hydraulic Bender allows easy access to the pipe for set up and removal. Benders are available in both manual and electric versions. An open wing version is available for ease of pipe loading and unloading.

The RIDGID Hydraulic Benders are generally designed to bend the following types of pipe:

- EN 10255 Medium and Heavy Series
- ASTM A53 Schedule 40 and 80
- DIN 2440, 2441 Series



Figure 2 – Hydraulic Pipe Bender 2" and 3" Electric Unit



Figure 3 – Open Wing Bender

The machine serial number is located on the side of the pump. The last 4 digits indicates the month and year of the manufacture. (03 = month, 10 = year).

NOTICE Selection of appropriate materials and installation, joining and forming methods is the responsibility of the system designer and/or installer. Selection of improper materials and methods could cause system failure.

Stainless steel and other corrosion resistant materials can be contaminated during installation, joining and forming. This contamination could cause corrosion and premature failure. Careful evaluation of materials and methods for the specific service conditions, including chemical and temperature, should be completed before any installation is attempted.

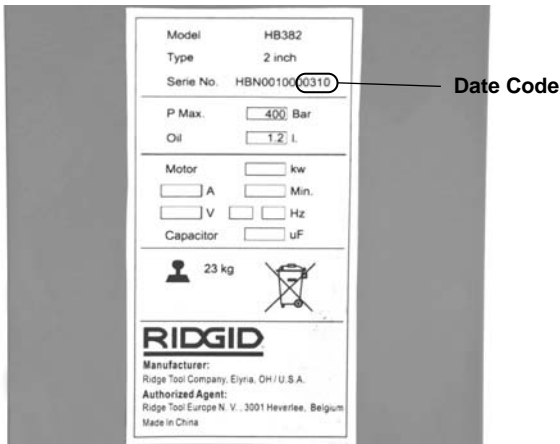

Figure 4 – Machine Serial Number

Specifications

Pipe Bender

Model No.	Capacity Inch	Pump Pressure (bar)	Ram Force kN(klb)	Pump Type	Motor		Approximate Equipment Dimensions L x W x H (cm)	Standard Formers	Shipping Weight		Crate Dimensions L x W x H (cm)
					Volt & Frequency	Power kW			lb	kg	
HB382	3/8" - 2"	450	90 (20.1)	Manual	N/A	N/A	73 x 63.5 x 62 28.8" x 25" x 24.4"	3/8", 1/2", 3/4", 1", 1 1/4", 1 1/2", 2"	159	72	82 x 33 x 49.5 32.3" x 13" x 19.5"
HB382E	3/8" - 2"	450	90 (20.1)	Electric	230/50Hz 1Φ 230/60Hz 3Φ 115/60Hz 1Φ 400/50Hz 3Φ	1.4 1.5 1.4 1.5	73 x 63.5 x 43 28.8" x 25" x 16.9"	3/8", 1/2", 3/4", 1", 1 1/4", 1 1/2", 2"	211	96	82 x 39.5 x 60 32.3" x 15.6" x 23.6"
HB383	3/8" - 3"	450	146 (32.7)	Manual	N/A		75.5 x 103 x 62 29.8" x 40.6" x 24.4"	3/8", 1/2", 3/4", 1", 1 1/4", 1 1/2", 2", 2 1/2", 3"	344	156	117 x 37.5 x 49.5 46.1" x 14.8" x 19.5"
HB383E	3/8" - 3"	450	146 (32.7)	Electric	230/50Hz 1Φ 230/60Hz 3Φ 115/60Hz 1Φ 400/50Hz 3Φ	1.4 1.5 1.4 1.5	75.5 x 103 x 62 29.8" x 40.6" x 24.4"	3/8", 1/2", 3/4", 1" 1 1/4", 1 1/2", 2", 2 1/2", 3"	401	182	117 x 46.5 x 62 46.1" x 18.3" x 24.1"
HBO382	3/8" - 2"	450	90 (20.1)	Manual	N/A	N/A	70.5 x 65 x 62 28" x 25.5" x 24"	3/8", 1/2", 3/4", 1", 1 1/4", 1 1/2", 2"	202	92	82 x 33 x 49.5 32.3" x 13" x 19.5"
HBO382E	3/8" - 2"	450	90 (20.1)	Electric	230/50Hz 1Φ 230/60Hz 3Φ 115/60Hz 1Φ 400/50Hz 3Φ	1.4 1.5 1.4 1.5	70.5 x 65 x 43 28" x 25.5" x 16.9"	3/8", 1/2", 3/4", 1" 1 1/4", 1 1/2", 2"	255	116	82 x 39.5 x 60 32.3" x 15.6" x 23.6"

Specifications (continued)

Operating Temperature: 14°F to 122°F (-10°C to 50°C) (See Maintenance Section for more information.)

All benders come with appropriate formers and corner supports for the size range, and are packaged in a reusable wooden crate. Formers are for pipes to EN10255 and equivalent as listed below:

Former

Catalog No.	Nominal Pipe Size	Pipe O.D.		Wall Thickness				Bend Radius*		Weight		Pipe** Type/Standard
				MIN.		MAX.						
				Inch	mm	Inch	mm	Inch	mm	Inch	mm	
37218	1/4"	0.540	13,5	0.08	2,2	0.16	4	2.36	60	2.2	1	EN10255, ASTM A53
37223	3/8"	0.675	17,2	0.09	2,3	0.16	4	1.77	45	1.8	0,8	EN10255, ASTM A53
37228	1/2"	0.840	21,3	0.10	2,6	0.16	4	1.97	50	2.4	1,1	EN10255, ASTM A53
37233	3/4"	1.050	26,9	0.10	2,6	0.16	4	3.15	80	4.0	1,8	EN10255, ASTM A53
37238	1"	1.315	33,7	0.13	3,2	0.20	5	4.33	110	4.0	1,8	EN10255, ASTM A53
37243	1 1/4"	1.660	42,4	0.13	3,2	0.20	5	5.31	135	4.6	2,1	EN10255, ASTM A53
37248	1 1/2"	1.990	48,3	0.13	3,2	0.20	5	6.10	155	9.5	4,3	EN10255, ASTM A53
37253	2"	2.375	60,3	0.14	3,6	0.22	5,5	8.66	220	14.4	6,5	EN10255, ASTM A53
37258	2 1/2"	2.875	76,1	0.14	3,6	0.28	7	12.60	320	38.5	17,5	EN10255, ASTM A53
37263	3"	3.500	88,9	0.16	4,0	0.30	7,6	15.35	390	59.9	27,2	EN10255, ASTM A53

* Bend radius to centerline of pipe. ** See description for more information.

Pre-Operation Inspection

⚠ WARNING



Before each use, inspect your pipe bender and correct any problems to reduce the risk of serious injury from electric shock, crushing injuries and other causes and prevent machine damage.

1. If an electric bender, make sure the ON/OFF switch is in the OFF (○) position and the power cord is unplugged.
2. Clean any oil, grease or dirt from the pipe bender, including the handles and controls. This allows better inspection of the pipe bender and helps prevent the pipe bender or control from slipping from your grip during use.
3. Inspect the bender for:
 - Hydraulic leaks. Check the hydraulic fluid level and adjust as needed (see Maintenance Section).
 - Any broken, cracked, bent, missing, misarranged or binding parts or any other condition that may prevent the safe and normal operation of the bender.

- Cracks or breaks in the formers and corner supports.
- Inspect the power cord and plug for damage or modification, such as cuts or a missing ground plug.
- Presence and legibility of the warning label. See Figure 5A and 5B.

If any issues are found during the inspection of the bender, do not use until those issues have been corrected.



Figure 5A – Warning Label (Manual)



Figure 5B – Warning Label (Electric)

4. If any other equipment is being used, inspect and maintain per its instructions to make sure it functions properly.

Machine And Work Area Set-Up

⚠ WARNING



Set up the bender and work area according to these procedures to reduce the risk of injury from electric shock, machine tipping, crushing and other causes, and to help prevent bender damage.

1. Locate a work area that has:
 - Adequate lighting.
 - No flammable liquids, vapors or dust that may ignite. The equipment is not explosion proof and can cause sparks.
 - Clear level, stable, dry location for all of the equipment and the operator.
 - Properly grounded electrical outlet of proper voltage. If in doubt, have outlet inspected by licensed electrician.
2. Clean the work area before setting up any equipment. Wipe up any oils or liquids. Clear anything that the pipe could hit during bending.
3. Inspect the pipe to be bent and installation area and confirm that you have the correct tool and formers for the job. *See the Specifications Section.* Do not attempt to bend pipe that exceeds the pipe bender specifications. This could damage the pipe bender.
4. Confirm that equipment to be used has been properly inspected.

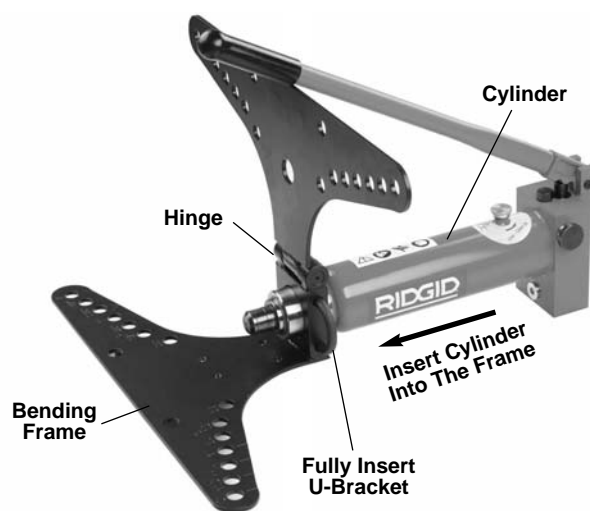

Figure 6 – Assembling 2" and 3" Benders

5. Assembly

All benders should be set up on the floor or other suitable surface. Bender parts are heavy and awkward. Use appropriate transport and lifting methods.

If using the accessory wheel stand or turnable tripod, follow instructions for proper set-up.

- Place the bending frame with the hinged side up.
- Insert the end of the cylinder into the opening at the end of the bending frame. Align the groove on the cylinder with the back of the bending frame.
- Fully insert the U-bracket through the joint between the bending frame and the cylinder.
- Place the corner supports on the lower bending frame over the appropriate holes for the size of pipe to be bent.
- Insert the pins through the bending frames to retain the corner supports.



Figure 7 – Assembled 2"/3" Electric Bender



Figure 8 – Assembled Open Wing Bender

6. Open the fill cap on the cylinder two full turns. This allows air into the reservoir during use for proper operation. (See Figure 11.)

Powering The Electric Bender

1. Confirm that the ON/OFF (I/O) switch is in the OFF (O) position.
2. Make sure that the power cord is routed away from the work area. Run the cord along a clear path to the outlet, and with dry hand plug in. Keep all connections dry and off the ground. If the power cord is not long enough, use an extension cord that:
 - Is in good condition
 - Has a plug similar to that on the tool.
 - Is rated for outdoor use and contains a W or W-A in the cord designation (i.e. SOW), or complies with H05VV-F, H05RN-F types or IEC type design (60227 IEC 53, 60245 IEC 57).
 - Has sufficient wire size (16 AWG (1.5mm²) for 50' (15.2m) or less, 14 AWG (2.5mm²) for 50' – 100' (15.2m – 30.5m) long). Undersized wires can over-heat, melting the insulation or causing a fire or other damage.

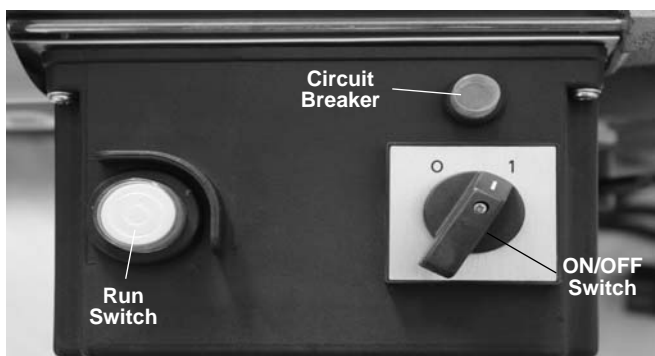

Figure 9 – Electric Bender Controls

3. Check the bender for proper operation.

Move the ON/OFF switch to the ON (I) position. Press and release the Run switch. If the ON/OFF switch and Run switch do not control the motor operation, do not use the bender until it has been repaired.

Depress and hold the Run switch. Inspect for misalignment, binding, odd noises or any other unusual conditions. Release Run switch. If any unusual conditions are found, do not use the machine until it has been repaired.

Move the ON/OFF switch to the OFF (O) position.

Operating Instructions

⚠ WARNING



Keep your fingers and hands away from the bending attachments and work piece during bending. Your fingers, hands and other body parts can be caught, crushed, fractured or amputated if they become entangled in the bender or between these components and any other object.

Properly support the tool and pipe. This will help to prevent the tipping of the pipe and equipment.

Pipe moves during bending and can cause striking or crushing injuries. Be sure there is adequate clearance around the pipe before bending

Follow operating instructions to reduce the risk of injury from entanglement, striking, crushing, electrical shock and other causes.

Loading The Pipe

1. Confirm that the equipment and work area has been properly set up and is free of by-standers and other distractions. Confirm ON/OFF switch is on the OFF (O) position.
2. If needed, mark the pipe to be bent at the appropriate location.
3. If needed, open the upper bending frame.
4. Choose the appropriate bending former for the pipe to be bent. Formers are marked with the size and catalog number. See the Specifications for more information. Place former over the end of the ram.
5. Place the pipe to be bent in front of the former and if needed place supports under the pipe to hold it in the correct position for bending. The former includes a

mark at the center for alignment. Properly support the pipe to prevent tipping of the pipe and the bender throughout use.

6. Apply grease to the side of the corner support that contacts the pipe. Place the supports at the appropriate holes as marked on the bending frame. The corner supports must be located in the correct, symmetrical holes or the bender can be damaged during use.



Figure 10 – Loading the Pipe

7. Close the bending frame and fully insert the corner support pins through both wings of the bending frame. Align the corner supports so that the zero marks on the angle indicators line up with the mark on the upper wing (See Figure 12).

Open wing benders do not have angle indicators. Make sure the pins are fully inserted into the lower wing.

8. Confirm that the bender and pipe are stable.

Advancing/Retracting The Ram

Turn the release knob clockwise on the hydraulic pump to the closed (advance ram) position (See Figure 11.) To retract ram, turn release knob counter clockwise to retract position. An internal spring will retract the ram.

Manual Pump

Move the pump handle up and down to advance the ram. Do not use handle extensions. This can damage the handle or slip during use and cause injury.



Figure 11 – Release Knob Positions (Advance/Retract)

Electric Pump

Move the ON/OFF switch to the ON (I) position. Press the RUN switch to ADVANCE the ram. Place ON/OFF switch in OFF (O) position when not in use or retracting the ram.

Bending The Pipe

1. Stand next to the cylinder on the same side as the Release knob. Do not reach over the machine to operate. Advance the ram. When the bending former touches the pipe, slowly and carefully advance the ram while aligning the bend location with the former. Continue advancing the ram until the pipe is just against the corner supports. Do not place your fingers, hands or other body parts in a position that would allow them to be trapped or crushed.
2. Confirm that the corner supports are in the correct position (as marked on the frame) for the pipe to be bent and the pins are fully inserted in the frame (See Figure 12). If not, the bender can be damaged during use. Make sure that the ends of the pipe extend past the corner supports enough to prevent the pipe from slipping off during bending. See Chart 1.

Chart 1 – Minimum Pipe Length Past The Center Of The Pin

Pipe Size O.D.		Min. Distance Center Line of Pin to End of Pipe	
Inch	mm	Inch	mm
1/4	13,5	1.6	40
3/8	17,2	1.6	40
1/2	21,3	1.9	47
3/4	26,9	2.0	51
1	33,7	2.1	54
1 1/4	42,4	2.3	58
1 1/2	48,3	2.5	63
2	60,3	2.2	56
2 1/2	76,1	3.3	84
3	88,9	3.7	93

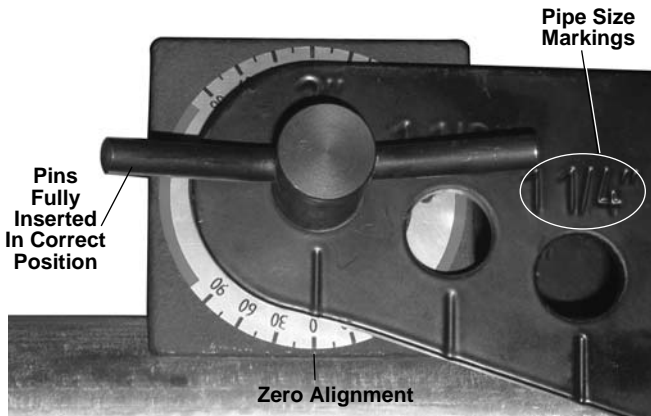

Figure 12 – Angle Indicator Alignment – Start of Bend

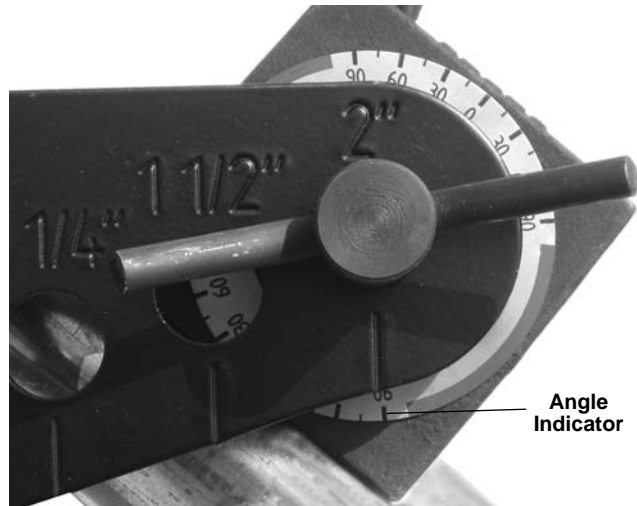

Figure 15 – Angle Indicator – End of Bend



Figure 13 – Operating the Manual Bender



Figure 14 – Operating the Open Wing Bender

3. Continue to advance the ram and bend the pipe. As the pipe is bent, the ends will move. Stay clear of the moving pipe. Monitor the angle indicators (Figure 15). The average of the angles measured by each angle indicator equals the approximate total angle bent.

Watch the ram as it extends. If you can see a small groove in the ram (Figure 16), stop advancing the ram to prevent hydraulic leaks and ram damage

4. For certain sizes of pipe (2 1/2", 3"), a ram extension must be used to form a 90 degree bend. When the groove in the ram (Figure 16) is visible, stop advancing the ram. Make sure that the pipe is properly supported to prevent it from moving or falling. Turn the release knob to the retract position, and retract the ram far enough to allow the extension to be inserted between the end of the ram and the former. Insert the extension and carefully advance the ram. Do not place your fingers, hands or other body parts in a position that would allow them to be trapped or crushed.



Figure 16 – Groove in Ram

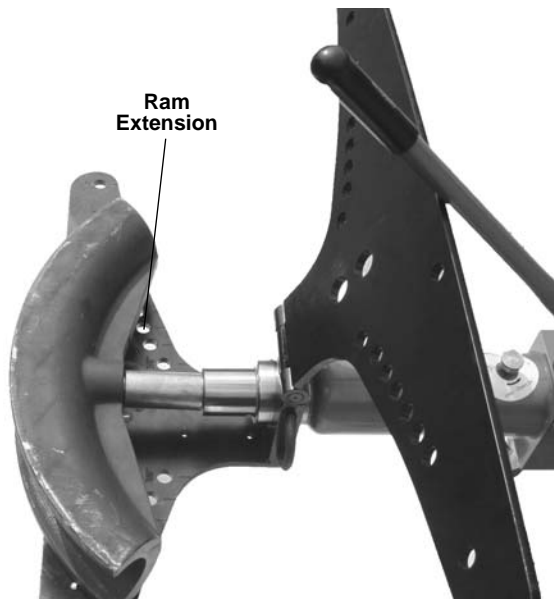

Figure 17 – Inserting the Ram Extension (Shown Open Without Pipe For Clarity)

As the desired degree of bend is reached stop advancing the ram. Do not try to create a bend of more than 90 degrees (per the angle indicator), this could cause kinking of the pipe and other issues. A square or other measuring device may be needed to measure exact bend angles. It is preferable to under bend the pipe as it is easier to bend the pipe a little more than to straighten it. When the ram is retracted, the pipe may spring back, so you may need to slightly compensate to get the desired angle.

5. With the bend complete, move the ON/OFF switch to the OFF (O) position. Retract the ram by turning the release knob to the retract position.
6. Remove the pipe from the bender. If needed, remove pins, corner supports and/or open the top wing. If the former is stuck to the pipe, a block of wood or a soft faced hammer can be used to tap the former off the pipe. Do not use regular hammers, chisels or other hardened tools to remove the former. They can chip and damage the former and cause injury.

Straightening Bends

A straightening former is available to slightly reduce the angle of a bend (up to approximately 10 degrees). Use of the straightening former may deform the bend. In some cases (such as 90 degree bends on 2½" or 3") the straightening former cannot be used. To use:

1. Place the straightening former on the end of the ram.
2. Place the pipe so that the bend sits against the straightening former and the legs of the bend are

against the corner supports. Make sure the set up is symmetric, with the corner supports in the correct position, to prevent damage to the bender.

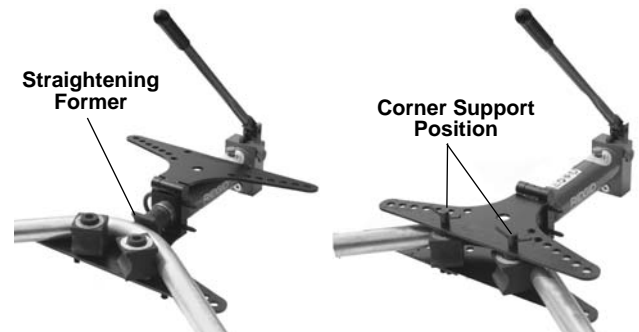

Figure 18 – Straightening a Bend

3. Follow the steps for “Bending the Pipe”.

Maintenance Instructions

⚠ WARNING

Maintain the hydraulic bender according to these procedures for a longer product life and to reduce the risk of injury from electrical shock and other causes.

Cleaning

After each use, wipe any oil or dirt off of the bender and formers with a clean, dry, soft cloth. Pay special attention to the ram and piston to remove any dirt or debris that could scratch polished parts or damage seals. If needed, the formers and corner supports can be cleaned with a wire brush.

Lubrication

Monthly, or more often if needed, apply a light machine oil or grease to handle pivot points, wing hinge, and pins. Do not apply oil to hydraulic system components.

Hydraulic Oil

Checking Level/Adding Hydraulic Oil

Before each use, check oil level. Place the bender on a flat level surface with the ram fully retracted. Remove the oil vent cap – oil should be even with the bottom of the fill neck. If oil is needed, add Shell Tellus 32 Hydraulic Oil or other equivalent high quality hydraulic oil and replace oil vent cap. See *Figure 10* for location of oil vent cap.

Changing

Once a year, or more often with heavy use or use in dusty conditions, the hydraulic oil should be changed.

Place the pump end of the hydraulic cylinder in a container to collect the hydraulic oil as it is drained. Directly under the cylinder is a plug (Figure 19). Remove the plug, filter spring and filter and allow the hydraulic fluid to drain. Open the oil vent cap and raise the ram end of the cylinder slightly to improve drainage. Complete drainage may take up to several hours. Properly dispose of the used hydraulic oil per the Material Safety Data Sheet (MSDS) and local requirements.



Figure 19 – Hydraulic Oil Drain Plug and Access to Filter

Clean the filter by rinsing in clean hydraulic oil. Re-install the clean or new filter, spring and plug. Fill the bender with new hydraulic oil following the instructions for adding hydraulic oil. Operate the bender through several cycles to remove air from the system and check the hydraulic oil level.

Oil Capacity

HB382/382E, HBO382/382E	1.27 QT./1.2 liter
HB383/383E	1.70 QT./1.6 liter

Low Temperature Operation

If the Hydraulic Bender will be used in low temperatures (Less than 14°F (-10°C)) it is recommended that the Hydraulic oil be changed to a high quality Hydraulic oil suitable for the temperature.

Accessories

⚠ WARNING

To reduce the risk of serious injury, only use accessories specifically designed and recommended for use with the RIDGID hydraulic benders, such as those listed below. Other Accessories suitable for use with other tools may be hazardous when used with the RIDGID hydraulic benders.

Hydraulic Pipe Bender Accessories

Catalog No.	Description
37293	Pins, HB382/HB382E
37273	Corner Supports, HB382/HB382E
37603	U-Bracket, HB382/HB382E
37618	Straightening Former, HB382/HB382E/HB383/HB383E
37298	Pins, HB383/HB383E
37278	Corner Supports, HB383/HB383E
37838	U-Bracket, HB383/HB383E
37828	Foot Wheels, HB382/HB382E/HB383/HB383E
37813	Turnable Tripod, HB382/HB382E/HB383/HB383E
38568	Extension, HB383/383E
42533	Corner Supports, HB0382/HB0382E
42543	Pins, HB0382/HB0382E

Machine Storage and Transportation

NOTICE The Hydraulic bender must be kept indoors or well covered in rainy weather. Store the machine in a locked area that is out of the reach of children and people unfamiliar with hydraulic benders. This machine can cause serious injury in the hands of untrained users. Store unit between 14°F (-10°C) and 122°F (50°C).

When preparing to move the hydraulic bender, always close the fill cap on the cylinder to prevent hydraulic oil from leaking.

Service And Repair

⚠ WARNING

Improper service or repair can make machine unsafe to operate.

The “Maintenance Instructions” will take care of most of the service needs of this machine. Any problems not addressed by this section should only be handled by an authorized RIDGID service technician.

Tool should be taken to a RIDGID Independent Authorized Service Center or returned to the factory.

Disposal

Parts of the hydraulic pipe bender contain valuable materials and can be recycled. There are companies that specialize in recycling that may be found locally. Dispose of the components in compliance with all applicable regulations. Contact your local waste management authority for more information.



For EC Countries: Do not dispose of electrical equipment with household waste!

According to the European Guideline 2002/96/EC for Waste Electrical and Electronic Equipment and its implementation into national legislation, electrical equipment that is no longer usable must be collected separately and disposed of in an environmentally correct manner.

Troubleshooting

PROBLEM	POSSIBLE REASONS	SOLUTION
Ram Does Not Advance.	Release Knob Not Fully Closed. Fill Cap Is Closed. Low Oil Level. Clogged Oil Filter. Air In Hydraulic System. Seals Are Worn/Damaged.	Close Release Knob. Open Fill Cap Two Full Turns. Check Oil Level. Change Hydraulic Oil/Clean Filter. Operate Bender Unloaded To Remove Air From System. Have Bender Serviced.
Motor Does Not Start.	Power Supply Not Connected. Motor Too Hot. Circuit Breaker Open.	Connect Power Supply. Allow Motor To Cool Down. Depress Circuit Breaker Reset On Motor Control. Check Power Supply Circuit Breaker.
Oil Leaks.	Seals Are Worn/Damaged.	Have Bender Serviced.
Pipe Kinks Or Buckles.	Pipe Wall Is Too Thin. Former is wrong size for pipe.	<i>See Description/Specification Section.</i> Use correct former.
Pipe Won't Bend.	Ram Does Not Advance. Pipe Wall Too Thick/Pipe Too Hard.	<i>See Above.</i> <i>See Description/Specification Section.</i>



99 Washington Street
Melrose, MA 02176
Phone 781-665-1400
Toll Free 1-800-517-8431

 Visit us at www.TestEquipmentDepot.com

**We
Build
Reputations™**

RIDGID®

EMERSON™
Commercial & Residential Solutions

EMERSON. CONSIDER IT SOLVED.™