

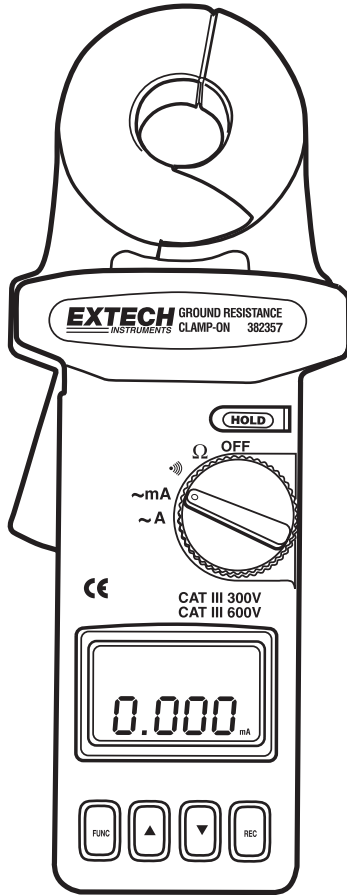

Ground Resistance Clamp On Tester

MODEL 382357



Warranty

EXTECH INSTRUMENTS CORPORATION warrants the basic instrument to be free of defects in parts and workmanship for one year from date of shipment (a six month limited warranty applies on sensors and cables). If it should become necessary to return the instrument for service during or beyond the warranty period, contact the Customer Service Department at (781) 890-7440 EXTENSION 210 for authorization or visit www.extech.com for more information. **A Return Authorization (RA) number must be issued before any product is returned to Extech.** The sender is responsible for shipping charges, freight, insurance and proper packaging to prevent damage in transit. This warranty does not apply to defects resulting from action of the user such as misuse, improper wiring, operation outside of specification, improper maintenance or repair, or unauthorized modification. Extech specifically disclaims any implied warranties or merchantability or fitness for a specific purpose and will not be liable for any direct, indirect, incidental or consequential damages. Extech's total liability is limited to repair or replacement of the product. The warranty set forth above is inclusive and no other warranty, whether written or oral, is expressed or implied.

Introduction

Congratulations on your purchase of Extech's 382357 Ground Resistance Tester. This Clamp-on device allows the user to measure ground resistance without the use of auxiliary ground rods. This device can only be used on multi-grounded systems. It is not necessary to disconnect the ground under test. Proper use and care of this meter will yield years of reliable service.

Safety

- Only qualified technicians should operate this meter.
- Use extreme caution when operating the meter near energized electrical equipment.
- Do not attempt to use this meter to twist or pry the ground electrode or ground wire away from grounded equipment.
- All metal objects or wires connected to the electrical system under test should be assumed to be lethal until tested. Grounded systems are no exception.
- Ensure that the batteries are inserted correctly in the battery compartment.
- Remove the batteries from the meter if the meter is to be stored for long periods.

WARNING: If the meter is used in a manner not specified by the manufacturer, the built in protections provided by the meter may be impaired.

International Safety Symbols



This symbol, adjacent to another symbol or terminal, indicates the user must refer to the manual for further information.





This symbol, adjacent to a terminal, indicates that, under normal use, hazardous voltages may be present

Description

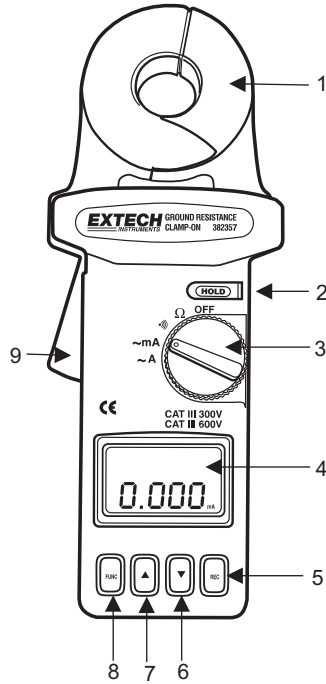
1. Jaw Assembly
2. Hold Button
3. Rotary Selector Switch
4. LCD Display
5. Record Button
6. ▼ (decrement) Button
7. ▲ (increment) Button
8. Function Button
9. Measurement Trigger



Display Symbols

Ω	Ohms (resistance measurement)
<i>mA</i> , <i>A</i>	milli-amperes, Amperes (current measurements)
•)))	Hi Lo alarm position
NOISE	Excessive noise on the ground conductor or rod
	Clamp jaws are not fully closed
	Low Battery
REC	Indicates data logging in progress
NO.	Indicates the READ function
H	Hold function activated

Specifications

General Specifications

Resistance Test Frequency:	3.333 kHz (15mV rms approx.)
Max Conductor size	0.9" (23mm)
Display	4-digit (9999 count) display
Sampling rate	0.5 seconds
Power supply	One 9V battery
Power consumption	40mADC
Battery Life	3000 measurements
Temp. Coefficient	0.15 times the specified accuracy per °C (from 39 to 64°F (4 to 18°C) and 82 to 122°F (28 to 50°C))
Current Overload	Protected to 100A Continuous; 200A for less than 60 seconds (50/60Hz)
Continuity check	Audible tone if reading is less than approx. 40Ω
Range selection	Automatic ranging
Safety	Meets the requirements for IEC1010-1 Category III 300V and Category II 600 V
Operating conditions	14 to 122°F (0 to 50°C) with < 85% RH
Storage conditions	-4 to 122°F (-20 to 60°C) with < 75% RH
Dimensions	10.1 x 3.9 x 1.9" (257 x 100 x 47mm)
Weight	1.4lbs (640g)
Accessories	Resistance check plate, 9V battery, & carrying case

Ground Resistance (Aurorange) Specifications

Range	Resolution	Accuracy (of reading)
0.025 to 0.250 Ω	0.002 Ω	$\pm (1.5\% + 0.05\Omega)$
0.250 to 1.000 Ω	0.02 Ω	$\pm (1.5\% + 0.05\Omega)$
1.001 to 9.999 Ω	0.02 Ω	$\pm (1.5\% + 0.1\Omega)$
10.00 to 50.00 Ω	0.04 Ω	$\pm (1.5\% + 0.1\Omega)$
50.01 to 99.99 Ω	0.04 Ω	$\pm (1.5\% + 0.5\Omega)$
100.0 to 200.0 Ω	0.4 Ω	$\pm (1.5\% + 1.0\Omega)$
200.1 to 400.0 Ω	2 Ω	$\pm (5.0\% + 5\Omega)$
400.0 to 600.0 Ω	5 Ω	$\pm (10\% + 10\Omega)$
600.1 to 1500 Ω	20 Ω	$\pm 20\%$

Accuracy Note: Loop resistance non-inductive, external field < 50A/m, external electrical field < 1 V/m, conductor centered

Ground / Leakage Current Specifications

Range	Accuracy (% of reading)
0.200 to 1.000mA	$\pm (2.0\% \pm 0.05\text{mA})$
1.00 to 10.00mA	$\pm (2.0\% \pm 0.03\text{mA})$
10.0 to 100.0mA	$\pm (2.0\% \pm 0.3\text{mA})$
100 to 1000mA	$\pm (2.0\% \pm 0.3\text{mA})$
0.20 to 4.00A	$\pm (2.0\% \pm 0.03\text{A})$
4.00 to 30.00A	$\pm (3.0\% \pm 0.03\text{A})$

Notes: Auto-range, 50/60Hz bandwidth, True RMS sensing, Crest Factor < 3.0

High and Low Alarm

	Range	Resolution
High Alarm	0-1500 Ω	1 Ω
Low Alarm	0-1500 Ω	1 Ω

Operation

Note: Ensure that the jaws are fully closed before testing.

Note: DO NOT clamp on to any conductor or open the clamp jaws during the start-up self-calibration (self-cal is identified by the LCD counting down from CAL5 to CAL1).

Ground Resistance Measurements

1. Open the clamp jaws and check that all surfaces are clean and free of dust, dirt, or any foreign substances. Clean if necessary.
2. Forcefully snap the clamp jaws open and closed several times.
3. Turn the meter on by moving the rotary switch to the ohms Ω position. DO NOT interrupt the start up procedure by opening the clamp jaws or clamping around a conductor. During self-calibration, the meter will display CAL5, CAL4, CAL3, CAL2 and CAL1.
4. Once the start-up calibration procedure is completed, the meter will sound a beep. Clamp on to an electrode or ground rod and read the value of ground resistance on the display.

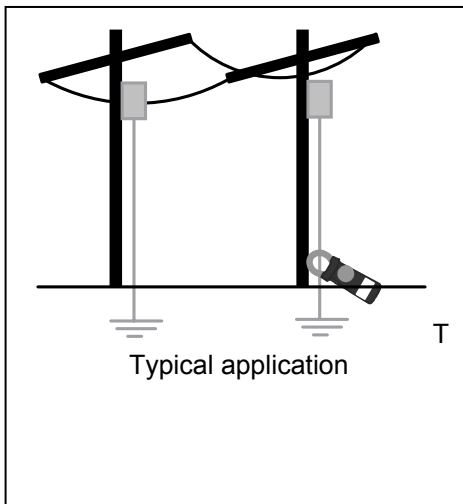

Ground / Leakage Current Measurement

1. Turn the meter on by moving the rotary switch to the mA or A position.
2. Clamp on to the electrode or conductor
3. Read the value of leakage current displayed on the LCD.

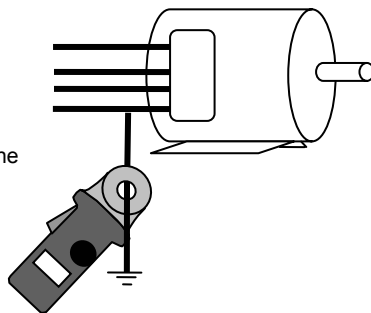

HOLD

Press the HOLD button to freeze the reading in the display.  will appear in the display. Press HOLD again to exit the function.

High and Low Alarm

1. Turn the meter on by moving the rotary switch to the **•)))** position.
2. Press the FUNC button to view and adjust the "HI" alarm value..
3. Press **▲** or the **▼** button to increase or decrease the value. Hold down the button to increase the speed of adjustment. The value can be incremented from 0 to 1500 ohms and then OL (overload). The value will roll over to 0 after OL is displayed.
4. Once the desired value is set, press the FUNC button a second time to view and adjust the "LO" alarm value.
5. Press the FUNC button three more times to exit the setting mode.
6. The meter will now compare the measured resistance value with the high and low limits when the meter is set to the **•)))** position. If the reading is larger than the HI value, the meter will beep and display "**HI**" on the LCD. If the reading is lower than the LO value, the meter will beep and display "**LO**" on the LCD.

Data Logging

Setting the Sampling Time

1. Press the FUNC button three times until the "**SEC**" symbol appears in the LCD display.
2. The sampling rate is now displayed in seconds.
3. Press the **▲** or the **▼** button to increase or decrease the value. The value can be incremented from 0 to 255 seconds.
4. Once the desired value is set, press the FUNC button several times until the characters in the upper row of the LCD disappear.

Recording Data

1. Press the REC button to start recording data at the specified sampling rate. The "**REC**" symbol will appear on the top of the LCD display. To stop recording, press the REC button. The "**REC**" symbol will no longer be displayed on the LCD.

NOTE: Data logging will automatically stop if the memory is filled (116 records), or if the meter detects a low battery condition.

NOTE: If the sampling interval is set to 0, only one sample will be recorded. To record another sample, press REC again.

Recalling Stored Data

1. Press the FUNC button four times until the "**NO.**" symbol is displayed on the LCD. The current record number will be displayed in the top row and the data will be displayed below it.
2. Press the **▲** or the **▼** button to step through and read the data in the next memory location. Holding down the button will increase the speed of the incrementing value.

Clearing Data Memory

1. With the meter powered off, press and hold down the REC button while turning the meter on. The "**CL**" symbol will appear on the display indicating that memory has been cleared.

Typical multi-grounded distribution system

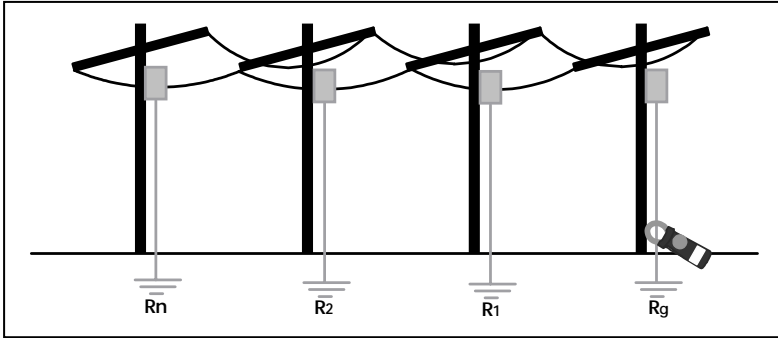

If the parallel ground resistances, R_1, R_2, R_3 , etc, up to R_n are combined as R_{eq} , then only R_g and R_{eq} are left in the circuit

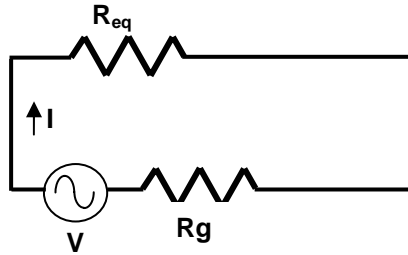

If a constant voltage is applied to the circuit, the following equation applies:

$$\frac{V}{I} = R_g + R_{eq} \quad \text{where: } R_{eq} = \frac{1}{\sum \frac{1}{R_i}}, i = 1, 2, \dots, n$$

If R_g and $R_1, R_2, R_3 \dots R_n$, are approximately the same, and n is large (200, for example), then R_{eq} will be much less than R_g and may possibly approach zero.

Example:

If R_g and $R_1, R_2, R_3 \dots R_n$ are all 10Ω respectively and $n = 200$, then R_{eq} by calculation equals:

$$R_{eq} = \frac{1}{\frac{1}{10} + \frac{1}{10} + \dots + \frac{1}{10}} = 0.05\Omega$$

$$\frac{V}{I} = R_g + R_{eq} = 10 + 0.05 = 10.05 \rightarrow R_g$$

Applications

Telephone-Electrical Ground Rods

1. Remove any protective covering from the ground conductor
2. Turn the meter switch to the Ohm Ω function.
3. Once the start-up calibration procedure is completed clamp on to an electrode or ground rod.
4. Allow several seconds for the meter to settle and then note the reading.

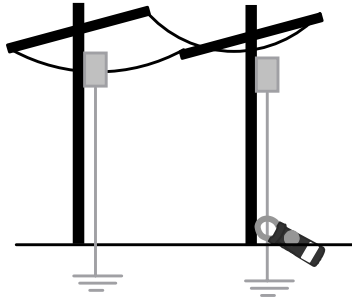

Cellular Transmission Towers

WARNING: Use extreme care when making measurements around transmission towers; High Voltage may be present.

The ground conductor should be located at the base of the tower, but your configuration may be different.

1. Locate the ground conductor
2. Clamp around the ground conductor. You should place the clamp before any splices, bonds or other splits in the ground system.
3. Read the measured reading.

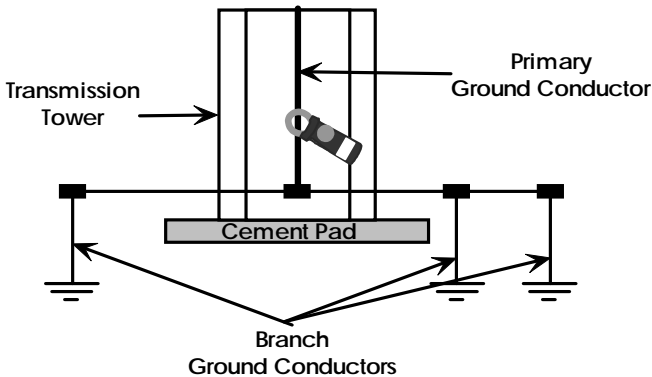

Service Entrance

Note: Multiple ground rods, multiple grounds i.e. ground rod(s) and water pipe grounds, or a combination may be present depending on the particular situation. In these situations it is necessary to make your measurements between the service-entrance neutral and all subsequent ground points.

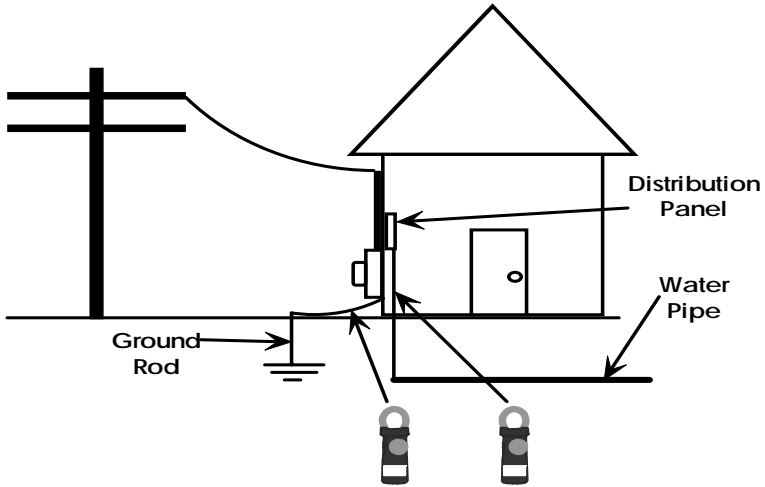

Troubleshooting

1. Snap the jaws open and closed two or three times before turning the meter on
2. Do not clamp on to any device during the power-up initialization sequence.
3. Snap the jaws two or three times after clamping on to the ground electrode or rod.
4. Slight amounts of drift may occur at high resistance measurements; this is normal and should not be cause for concern.

Blank display or any failure mode

Replace the battery before proceeding.

Start-up Initialization Failure

The start-up calibration will continue indefinitely if the jaws are open or dirty. Check that the jaws' mating surfaces are clean. Do not open the jaws while the initialization sequence is running.

Noise on the Ground Electrode or Rod

If noise is present (over 3A or 30V) on the ground electrode or rod, the word "**NOISE**" will appear on the display and readings can no longer be considered accurate. Before the meter can be used accurately, the noise problem must be addressed.

Reference Test Loop

The reference test loop is a set of resistors that provides a means to check the performance of the meter.

1. Open the measurement jaws and check that the mating surfaces are clean and free of dust, dirt, or any foreign substances. Clean if necessary.
2. Clamp the meter around the reference loop as shown in the diagram.
3. Give the meter a few seconds to settle and read the measurement. The meter should display approximately the same value as marked on the reference loop, taking into consideration the accuracy listed in the specification chart. If the readings are not similar to what is marked on the reference loop, consult the **Trouble Shooting** and **Maintenance** sections of this manual.

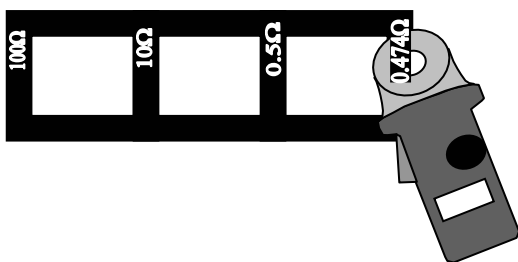

Maintenance

General Care

Store the ground resistance tester and reference loop in its case when not in use. A damp cloth may be used to clean any surface dirt from the meter. Never use harsh detergents, abrasives, solvents, or cleaners on the meter.

Battery Replacement

When the low battery symbol appears on the display, replace the meter's 9V battery. Use a high quality alkaline battery whenever replacement becomes necessary.

1. Remove the two rear screws and open the meter housing.
2. Replace the battery, close the meter housing, and affix the two rear screws.

Clamp Jaw Maintenance

The jaws may be brushed clean with a toothbrush or similar soft-bristled brush. Care must be taken to ensure that the contact fins are not bent or deformed, as this will affect the operation of the meter.

Calibration and Repair Services

Extech offers repair and calibration services for the products we sell. Extech also provides NIST certification for most products. Call the Customer Service Department for information on calibration services available for this product. Extech recommends that annual calibrations be performed to verify meter performance and accuracy.



Support line (781) 890-7440

Technical support: Extension 200; E-mail: support@extech.com

Repair & Returns: Extension 210; E-mail: repair@extech.com

Product specifications subject to change without notice

For the latest version of this User's Guide, Software updates, and other up-to-the-minute product information, visit our website: www.extech.com

Copyright © 2004 Extech Instruments Corporation

All rights reserved including the right of reproduction in whole or in part in any form

Test Equipment Depot - 800.517.8431 - 99 Washington Street Melrose, MA 02176
FAX 781.665.0780 - TestEquipmentDepot.com