



Visit us at [www.TestEquipmentDepot.com](http://www.TestEquipmentDepot.com)



Back to the Extech 461830 Product Page

## User's Guide

# **EXTECH**

**INSTRUMENTS**

## Digital Stroboscope Tachometer

### Model 461830 and Model 461831

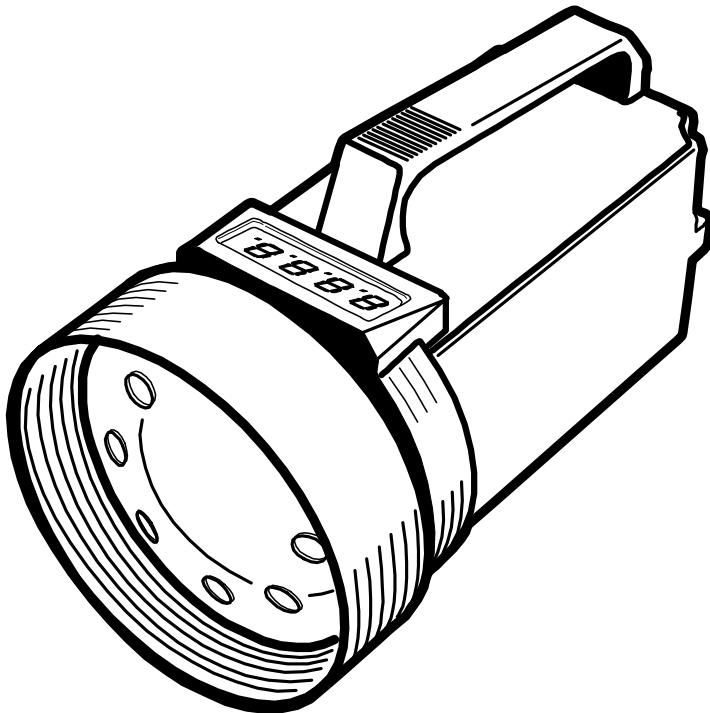

## Safety

---



This symbol, adjacent to another symbol or terminal, indicates the user must refer to the manual for further information.



This symbol, adjacent to a terminal indicates that, under normal use, hazardous voltages may be present

**WARNING:** Do not look directly at the Strobe's Xenon lamp or its reflector.

**WARNING:** This device causes moving objects to appear still. Take precautions against accidental contact with moving objects.

**CAUTION:** Do not touch the flash tube.

# Specifications

## General Specifications

Circuit	Exclusive one-chip LSI circuit with crystal time base
Display	4-digit (10,000 count; 0 to 9999) LED display
Measurement unit	RPM (revolutions or rotations per minute) is the speed of the moving device under test which equals the FPM rate (strobe flashes per minute)
Operating Temperature	32 to 122°F (0 to 50°C)
Operating Humidity	< 80% RH
Power Supply	110VAC (461830) or 220VAC (461831) 50/60Hz ±10%
Power Consumption	<25 watts @ 115V
Weight	2.2 lbs. (1kg)
Dimensions	8.3 x 4.8 x 4.8" (21 x 12 x 12cm)
Housing construction	Impact resistant plastic with plastic lens and mirrored reflectors

## Electrical Specifications

Measurement Range	100 to 10,000 RPM/FPM
Resolution	0.1 (<1000 RPM/FPM) 1 (1000 to 9999 RPM/FPM) 10 (10,000 RPM/FPM)
Accuracy	± (0.05% + 1 digits)
Sampling Time	1 second
Strobe Flash adjust range	LOW: 100 to 1,000 RPM/FPM HIGH: 1000 to 10,000 RPM/FPM
Strobe Flash tube type	Xenon lamp
Strobe Flash duration	60 to 1000 microseconds
Strobe Flash Energy	4 Watt-Seconds (Joules)
Strobe Beam Angle	80°
Strobe Flash Color	White 6500°K

**Notes:** Replace the Xenon lamp when readings appear irregular. To prolong the Xenon lamp life and ensure safe operation, please adhere to the following recommendations.

- A 30-minute use limit < 3000rpm and 5-minute use limit > 3000rpm exists. Do not use the instrument for periods longer than specified otherwise damage to the instrument may result.
- Always permit a 10-minute cool-down between cycles.
- Do not touch the Xenon flash tube.

# Meter Description

---

1. Xenon lamp
2. LED Display
3. Grip handle
4. COARSE adjust knob
5. FINE adjust knob
6. Power ON/OFF switch
7. Range Select Switch
8. AC power cord and jack

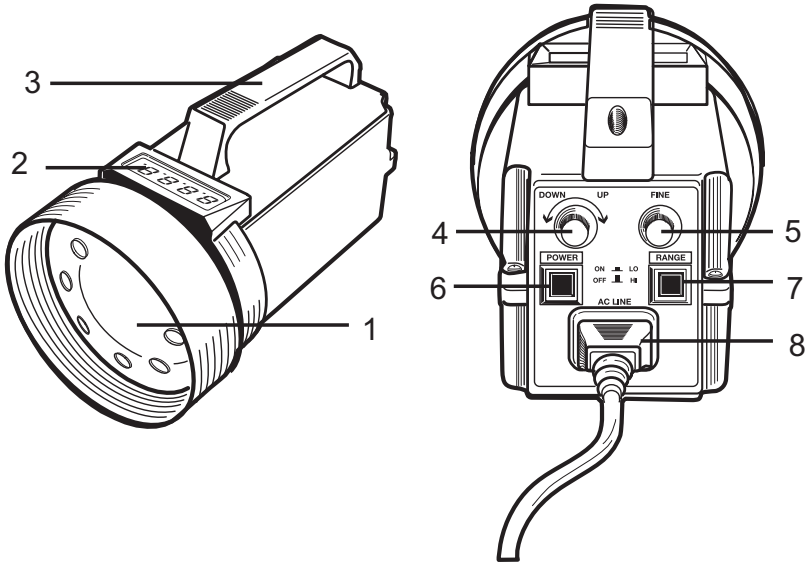

# ***Operation***

---

## **Powering the instrument**

1. Plug the supplied power cable into the instrument's power cable jack.
2. Plug the other end of the cable into an appropriate AC power source. The Model 461830 requires 110VAC and the 461831 requires 220VAC. Do not plug the device into an incorrect power source otherwise damage to the instrument will result.
3. Use the ON/OFF switch to turn the instrument on or off.

## **Speed (RPM) Measurements**

1. Remove power to the device under test so that it is stationary.
2. Affix a reflective mark or place a small piece of the supplied reflective tape on the device under test.
3. Point the Stroboscope's beam toward the reflective mark.
4. Use the 'FINE' and 'COARSE' adjustment knobs to synchronize or "stop" the motion of the reflective mark (read the 'Display Notes' section below).
5. Read the RPM value on the LED display.

## **Range Adjustments**

1. While measuring, use the RANGE button to select the range as desired
2. The LOW range is used for measurements below 1,000 RPM. The HIGH range is used for measurements above 1,000 RPM.

## Display Notes for Speed Measurements

Care must be taken to ensure that the reflective mark is providing a 1:1 measurement. Check that there is only one mark and not two, four, or more stationary marks on the object under test.

Two or more stopped marks indicate a 'harmonic' measurement (2:1, 3:1, 4:1 etc.) and the instrument will display double, triple, or quadruple the actual speed. A useful method of avoiding harmonic measurements is to adjust the FINE/COARSE knobs until two images (reflective marks) appear and then lower the flash rate (via COARSE/FINE knobs) until a single, stationary image appears. This will be the actual speed.

In the example below, a rotating shaft is affixed with one piece of reflective tape. The illustrations below represent several possible images that would appear when the strobe beam is pointed to the shaft.

If more than one reflective mark appears (as in columns 3, 4, and 5 below) the image is showing a 'harmonic'. The bold column (column 2) shows the actual speed of the shaft. Column 1 shows a harmonic whereby the actual speed is divided in half. Because of this, it is good practice to adjust the 'FINE' and 'COARSE' knobs until you can see the 'doubled harmonic' (Column 3) and then the 'halved harmonic' (Column 1) and then find the setting in-between (Column 2 in bold).



Shaft speed	1000rpm	<b>1000rpm</b>	1000rpm	1000rpm	1000rpm
Strobe flash rate	500rpm	<b>1000rpm</b>	2000rpm	3000rpm	4000rpm
Visible reflective marks	1	<b>1</b>	2	3	4

Note that the LED display has an AUTO RANGE INDICATOR (flashing decimal at the far right) that appears when the readings are over 10,000 RPM. In these cases, multiply the displayed reading by 10.

### Visually inspecting a moving object (stop-motion)

When the speed of the moving object matches the flash rate of the stroboscope, the moving object appears still. Measure the speed of a moving object as described in the previous sections to obtain a stop-motion. Once stop-motion is achieved, the FINE adjust knob is used to vary the viewing perspective of the object under test for visual inspection.

### Important note on Test Durations

The Xenon lamp used in this instrument has time restrictions on usage. If the specified test times and cool-off periods (shown in the table below) are not observed, damage to the instrument can result and the life span of the lamp can be shortened.

RPM	Max. Operating Time	Cool-Off Time
< 3,000 rpm	30 minutes	10 minutes
> 3,000 rpm	5 minutes	