

# INSPECTION TROLLEY OPTIMIZES YOUR VIEW.

## Wohler VIS Camera Trolley

FLEXIBILITY IN DUCTWORK AND PIPES

# SAVE MOVEMENT IN DARK PIPES.



## WOHLER VIS CAMERA TROLLEY

Positions the camera head perfectly in the pipe

**A crisp image of every detail in the pipe: That is what perfect video inspection is all about.**

Wohler camera optics ensure crystal clear imagery. And the Wohler VIS camera trolley makes it possible to view every inch of the pipe or duct with ease. Clever details ensure it easily rounds every bend. No detail is overlooked during the inspection, because the camera head is always guided through the middle of the pipe.

# Premium flexibility

The Wohler VIS camera trolley is designed for use in air ducts sized dia 6" and above or 6 x 6", in waste water pipes and air ducts as well as seamless chimneys. And that guaranteed in combination with every Wöhler VIS camera head. A particularly practical aspect: It can be used in combination with customary accessories such as supplementary lighting, the stabilization sleeve and coupling protection sleeve. The best possible view in the pipe is guaranteed, because the Wöhler camera trolley offers

numerous adjustment options: And they can be set with just one hand. The camera head is securely attached on the trolley or hangs protected below the trolley. That ensures the best-possible clearance between the optics and the pipe walls.

It is also possible to push the camera trolley forward in any position: Even when it tips to one side, it just keeps on rolling on.

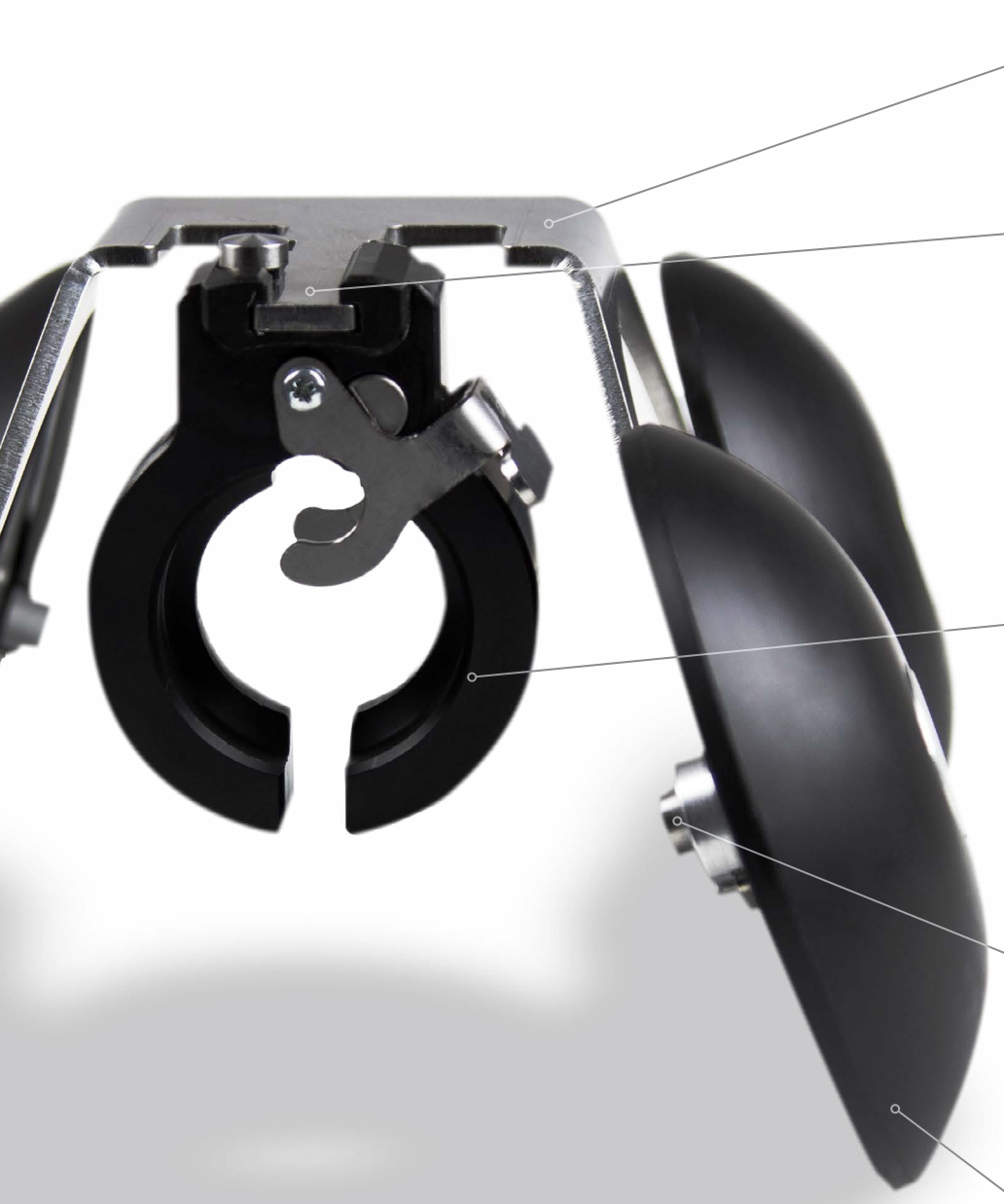

## Rugged body

Made of corrosion and acid-resistant stainless steel, but weighs in at just 1.5 lbs.

## Lock rail

The lock rail allows the user to adjust the position of the camera head holding fixture forward and back 3 steps. The camera head can lay fixed on top of the trolley or securely hang below the trolley.

## Camera head holding fixture

Suitable for all Wohler camera heads (dia 1", dia 1.5", dia 2") as well as a variety of accessory parts such as supplementary lighting and stabilization sleeve.

## Adjustable wheel height

The height setting rail facilitates setting the height of the camera trolley to three different heights.

## Plastic wheels

Ensure optimum movement in round and flat ducts

## TECHNICAL DATA

### Wohler VIS Camera Trolley

Material of the trolley .....	Stainless steel
Material of the wheel .....	POM
Height (adjustable) .....	30" – 35"
Width (adjustable) .....	5" – 5.5"
Weight .....	1.5 lbs

## Application examples – Wohler VIS Camera Trolley



The camera trolley remains in operation even when in a tilted position.



Wohler VIS Camera Head dia 1.5" with supplementary lighting and stabilization sleeve.



Wohler VIS Camera Head, dia 1" with supplementary lighting attached below the trolley.



Camera holding fixture on top securing the Wohler VIS Camera Head, dia 2" and supplementary lighting as well as a stabilization sleeve.

Scope of delivery	Wohler VIS Camera Trolley	Wohler VIS Camera Trolley - Set
Wohler VIS Camera Trolley	•	•
Camerahead-holder	•	•
Storage bag Wohler VIS Camera Trolley	•	•
Stabilizing sleeve for Supplementary Light detachable or VIS cameraheads Ø 2"		•
Stabilizing sleeve for adaptation of push rods with threaded connection M10		•
Article-no.	4705	4753
<b>Order</b>	Yes <input type="checkbox"/>	Yes <input type="checkbox"/>
Enter amount		