

# THERMO-ANEMOMETER TEST INSTRUMENT

Measures Air Velocity or Air Volume and Temperature Simultaneously

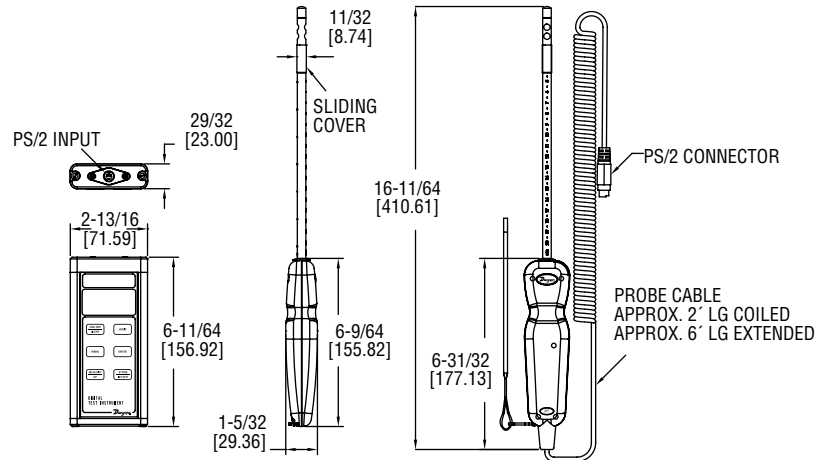

New Six Button Operation  
Provides Quick Access  
to Enhanced Features



Scan here  
to watch  
product video

The **MODEL 471B** Thermo-Anemometer Test Instrument is a versatile dual function unit that quickly and easily measures air velocity or volumetric flow as well as air temperature in imperial or metric units. A stainless steel probe is included, which has a comfortable hand grip and etched insertion depth marks. The extruded aluminum housing fully protects electronics, yet is lightweight and comfortable to hold.

#### FEATURES/BENEFITS

- High contrast and backlit LCD for visibility in any condition
- Able to store up to 99 readings
- Integral sliding cover protects probe sensors when not in use
- Built-in volumetric air flow calculations

#### APPLICATIONS

- Duct traverses
- HVAC inspections
- Testing and balancing

#### MODEL CHART

Model	Description
471B-1	Digital thermo anemometer includes 9V battery, sensing probe, wrist strap, soft carrying case and instructions

#### ACCESSORIES - CASES

Model	Description
UHH-C1	Spare soft carrying case
A-160-CASE	Hard carrying case for longer probes (18" to 36")

#### ACCESSORIES - PROBES

Model	Probe Length	Description
AP1	8"	Thermo anemometer air velocity & temperature probe with coiled cable
AP1-18	18"	Thermo anemometer air velocity & temperature probe with coiled cable
AP1-24	24"	Thermo anemometer air velocity & temperature probe with coiled cable
AP1-36	36"	Thermo anemometer air velocity & temperature probe with coiled cable

#### SPECIFICATIONS

**Service:** Air velocity and temperature of clean, dry air.

**Temperature Limits:** Process air velocity: -20 to 212°F (-29 to 100°C); Process temperature: -40 to 212°F (-40 to 100°C); Ambient: 5 to 125°F (-15 to 51°C).

**Display:** 4.5 digit LCD.

**Resolution:** 0.1%, 0.1 °F/°C.

**Range Air Velocity:** 0 to 6000 FPM (0 to 30 m/s).

**Accuracy Air Velocity:** ±3% FS within temperature range of 40 to 90°F (4 to 32°C).

**Range Volumetric Air Flow:** 19,999 in selected flow units.

**Range Temperature:** -40 to 212°F (-40 to 100°C).

**Accuracy Temperature:** ±0.5°F (±0.28°C) from 32 to 122°F (0 to 50°C); ±1.5°F (±0.83°C) from -40 to 32°F (-40 to 0°C) & 122 to 212°F (50 to 100°C).

**Probe Length:** 8" (203 mm) insertion.

**Cable Length:** 28" (71 cm) retracted, 6 ft (183 cm) extended.

**Power Requirements:** 9 V alkaline battery, installed non-functional, user replaceable.

**Weight:** 16 oz (454 g).

**Agency Approvals:** CE.



Replaceable Probe with  
Secure 6 Pin Adapter



Soft Carrying Case  
Included with Every Unit

Test Equipment  
Depot  
1-800-517-8431

99 Washington Street  
Melrose, MA 02176  
Phone 781-665-1400  
Toll Free 1-800-517-8431