

Chargebuster® Overhead Ionizer Installation, Operation and Maintenance



Made in the
United States of America



Figure 1. Desco [60640](#) Chargebuster® Overhead Ionizer

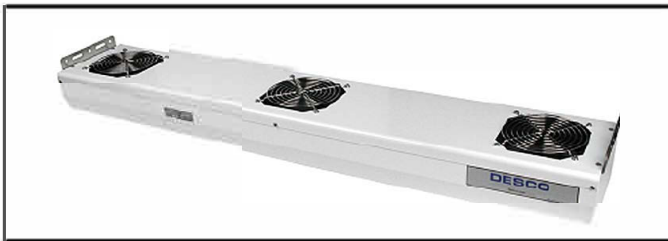

Figure 2. Desco [60473](#) Chargebuster® Overhead Ionizer



Figure 3. Desco [60467](#) Chargebuster® Overhead Ionizer with Light



Figure 4. Desco [60468](#) Chargebuster® Overhead Ionizer with Lights

Description

Desco Chargebuster® Overhead Ionizers are steady-state DC ionizers designed for use in ESD protected areas. The 2-fan ionizers ([60640](#), [60467](#)) have a 2' x 4' coverage area, and the 3-fan ionizers ([60473](#), [60468](#)) have a 2' x 5' coverage area. The Chargebuster® Overhead Ionizers' discharge times (< 3 seconds at 18") and low offset voltage (± 10 volts) meet the required limits of ANSI/ESD S20.20 < ± 35 volts tested per ANSI/ESD STM3.1 and ESD TR53. Its emitters are made of pure tungsten and spaced further apart to minimize ion recombination, increase discharge efficiency and provide a broader coverage area. The fans have 3 speeds (high, medium, low) which produce consistent performance at all 3 settings. The Chargebuster® Overhead Ionizers utilize an auto-feedback system that continuously optimizes its performance and automatically alarms and shuts down should its supply voltage drop.

The Desco [60467](#) and [60468](#) Chargebuster® Overhead Ionizers include 700 lumen light panels (cool white) that provide additional illumination to the work area and improve visibility and productivity. The [60467](#) features one light panel, and the [60468](#) features two.

"Necessary non-conductors in the environment cannot lose their electrostatic charge by attachment to ground. Ionization systems provide neutralization of charges on these necessary non-conductive items (circuit board materials and some device packages are examples of necessary non-conductors). Assessment of the ESD hazard created by electrostatic charges on the necessary nonconductors in the work place is required to ensure that appropriate actions are implemented, commensurate with risk to ESDS [ESD sensitive] items". (ANSI/ESD S20.20 Foreword)

"In order to mitigate field-induced CDM [Charged Device Model] damage, the ESD program shall include a plan for the handling of process-required insulators. If the field exceeds 2,000 volts/inch, steps shall be taken to either: A) Separate the insulator from the ESD-sensitive device by a distance of 30 cm (12 inches); or B) Use ionization or other charge mitigating techniques to neutralize the charge." (ANSI/ESD S20.20 section 8.3)

"The primary method of static charge control is direct connection to ground for conductors, static dissipative materials, and personnel. A complete static control program must also deal with isolated conductors that cannot be grounded, insulating materials (e.g., most common plastics), and moving personnel who cannot use wrist or heel straps or ESD control flooring and footwear."

“Air ionization is not a replacement for grounding methods. It is one component of a complete static control program. Ionizers are used when it is not possible to properly ground everything and as backup to other static control methods. In clean rooms, air ionization may be one of the few methods of static control available.” (ESD Handbook ESD TR20.20 Ionization, section 5.3.6.1)

The Chargebuster® Overhead Ionizer is available in four models:

Item	Fans	Lights	Input Voltage	Power Cord
60640	2	0	120 VAC	North America
60473	3	0	120 VAC	North America
60467	2	1	120 VAC	North America
60468	3	2	120 VAC	North America

Packaging

- 1 Chargebuster® Overhead Ionizer
- 1 Hanging Kit
- 1 Power Cord, North American Plug
- 2 Emitter Point Cleaners (60640, 60467)
- 3 Emitter Point Cleaners (60473, 60468)
- 1 Certificate of Calibration

Installation

The Chargebuster® Overhead Ionizer is designed to mount above the work area, providing even coverage without using valuable worksurface area. Mounting is a matter of personal preference. Use the included hanging kit to suspend the ionizer with its brackets, or secure its brackets to a shelf. Ensure that the mounting is secure and capable of supporting the weight of the ionizer. The power cord should be supported as well to protect the operator from any hazard.

The ideal mounting height is 18" above the worksurface, although the ionizer may be located slightly higher or lower if required. For optimum performance, ensure that the intake grills for the fans are not obstructed.

Verify that the ON/OFF switch located at the back of the ionizer is in the OFF position. Plug the power cord into the ionizer, and plug the other end into a properly wired power outlet.



Figure 5. Fan Speed Switch, Power Input and Power Switch

Operation

1. Set the fan speed switch to the LOW, MED, or HI position. Higher airflow will result in faster neutralization rates.
2. Position the ionizer so that maximum airflow is directed towards the items or area to be neutralized.
3. Turn the unit ON. When the unit is first turned on, it conducts a self-test. The audible alarm will sound and the LED will cycle through the colors red, yellow and green. The LED will remain green during normal operation.
4. Toggle the light switch on the front of the ionizer to ON to power the LED panel(s) (60467, 60468 only).

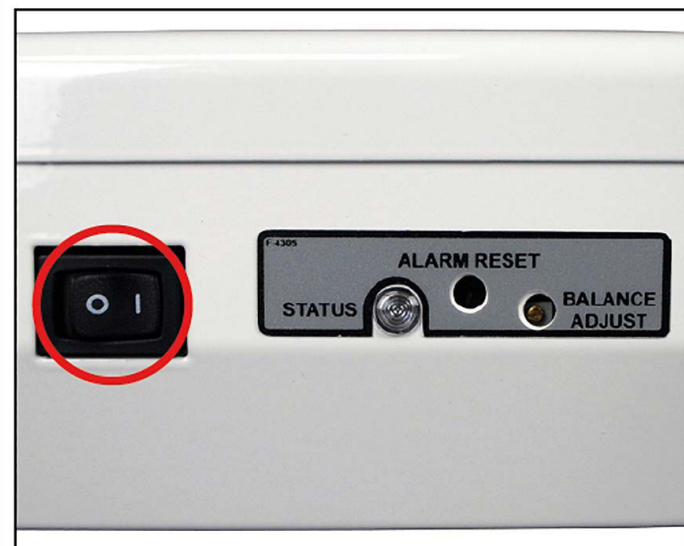

Figure 6. Light Switch (60467 and 60468 models only)

Maintenance

“All ionization devices will require periodic maintenance for proper operation. Maintenance intervals for ionizers vary widely depending on the type of ionization equipment and use environment. Critical clean room uses will generally require more frequent attention. It is important to set-up a routine schedule for ionizer service. Routine service is typically required to meet quality audit requirements.” (ESD Handbook TR20.20 section 5.3.6.7 Ionizer Maintenance / Cleaning)

EIA-625, recommends checking ionizers every 6 months, but this may not be suitable for many programs particularly since an out-of-balance may exist for months before it is checked again. ANSI/ESD S20.20 section 6.1.3.1 Compliance Verification Plan Requirement states: “Test equipment shall be selected to make measurements of appropriate properties of the technical requirements that are incorporated into the ESD program plan.”

CLEANING THE EMITTER POINTS

Under normal conditions, the ionizer will attract dirt and dust (especially on the emitter points). To maintain optimum neutralization efficiency and operation, cleaning should be performed on a regular basis.

In the event of circuit failure, the unit will enter shutdown mode.

When the unit enters shutdown mode, ionization will be stopped, the LED on the front of the unit will illuminate a constant red, and the audible alarm will continuously sound. The user must then reset the unit by turning it OFF and back ON.

The emitter points should be cleaned using the included Emitter Point Cleaners or a swab dampened with Isopropyl alcohol.

1. Turn the unit OFF and unplug the power cord.
2. Open the top screen by loosening the screw and swinging the grill to one side.
3. Clean the emitter points using the included Emitter Point Cleaners or a swab dampened with Isopropyl alcohol.
4. Reattach the top screen.
5. Plug in the power cord and turn the unit ON.
6. Verify the performance of the ionizer by using a charged plate monitor, or ionization test kit.



With normal handling, the emitter points should not require replacement during the life of the unit. If necessary, item [60507](#) Replacement Emitter Points are available for purchase.

Adjustments and Compliance Verification

BALANCE OFFSET VOLTAGE ADJUSTMENT

The Chargebuster® Overhead Ionizer is an auto-balancing unit. However, tuning or manual adjustment can be accomplished by inserting a small screwdriver or trimmer adjustment tool into the balance adjustment hole. To increase the output in a positive direction, turn the potentiometer clockwise. To increase the output in a negative direction, turn the potentiometer counter-clockwise.

INPUT VOLTAGE CONFIGURATION

WARNING - Risk of electric shock

These servicing instructions are for use by qualified personnel only. Do not perform any servicing of internal parts unless you are qualified to do so.

NOTE: The AC power cord MUST always be disconnected before the unit is disassembled.

The input voltage may be verified or reset by opening the ionizer's enclosure. This can be accomplished by removing the 10 screws that secure the cover to the base.

The ionizer's input voltage can be configured to 120 VAC or 220 VAC using the JH1 jumpers located on its PCB. See Figures 7 and 8 for these configurations.

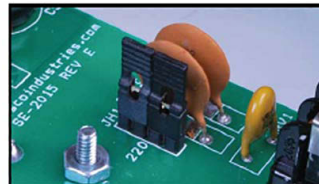

Figure 7. 120 VAC jumper setting

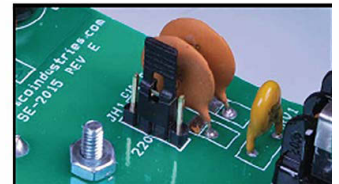

Figure 8. 220 VAC jumper setting

If the supply voltage drops from 110 Volts to below 85 Volts or from 200 Volts to below 170 Volts, the unit will shut down, the audible alarm will beep and the LED will blink red. The unit will automatically reset when the minimum voltage is restored.

Calibration

When an alarm sounds, most users will clean emitter pins (see Maintenance / Alarms section) and calibrate the ionizer. Per ESD TR53 section 5.3.6.7.1 "The best practice is to measure the offset voltage and discharge times, clean the unit, including emitter points and air filters if present, offset voltage to zero (if adjustable), and then repeat offset voltage and discharge time testing. If the unit does not meet offset voltage specifications or minimum established discharge time limits, further service is indicated. Manufacturers should provide details on service procedures and typical service intervals."

Most companies will assign a number or otherwise identify each ionizer and setup a Compliance Verification / Maintenance / Calibration schedule. If the ionizers all test good, the data can justify lengthening the calibration period. If ionizers require adjustment the calibration period should be shortened. Although ESD TR53 does not advise a test frequency, JESDD625-A (Revision of EIA-625) recommends ionizers be tested semiannually, noting to use "S3.1 except the number of measurement points and locations may be selected based on the application."

NOTE: A charged plate analyzer or monitor should be used in order to properly calibrate the Chargebuster® Overhead Ionizer (see the EMIT 50571 Charged Plate Analyzer).

1. Properly setup the ionizer as described in the Installation procedure on page 1.
2. Turn the unit ON and set the FAN SPEED to HIGH.
3. Position the charged plate analyzer 18 inches underneath one of the fans of the ionizer.

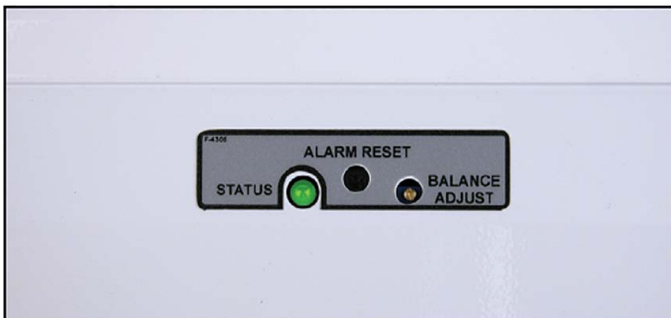

Figure 9. Calibration controls

4. Push and hold the ALARM RESET button on the ionizer until the STATUS LED turns red. Release the button and the LED should switch back to green. This allows the user to calibrate the balance (offset voltage) of the ionizer without setting off the alarm.
5. The balance (offset voltage) of each fan should be within 0 and ± 10 volts. The required limit per ANSI/ESD S20.20 is less than ± 35 volts. To increase the output in a positive direction, turn the BALANCE ADJUST potentiometer in a clockwise direction. To increase the output in a negative direction, turn the BALANCE ADJUST potentiometer in a counter-clockwise direction.
6. Test the neutralization (discharge) times by applying $\pm 1,000$ volts on the charged plate. The neutralization (discharge) time typically will be less than 3 seconds when charged plate analyzer is directly under a fan. See the "Neutralization (Discharge) Times" section for typical discharge times. The required limit per ANSI/ESD S20.20 is "user defined".
7. Submit the balance (offset voltage) to the ionizer's control circuit by quickly pressing the ALARM RESET button. The STATUS LED should turn off and then illuminate green to verify that the control circuit was successfully programmed.
8. Test each fan's alarm by shorting its two grills located on the bottom side of the ionizer. The alarm should sound and the STATUS LED should illuminate red.



Figure 10. Shorting the ionizer's two fan grills

Neutralization (Discharge) Times

All data was taken with the fan speed set to high. All time measurements are in seconds. The distance between the overhead ionizer and charged plate is 18" per ANSI/ESD STM 3.1.

NOTE: Discharge times in seconds are representative only and are not a guarantee. Discharge times are actual measurements recorded in a factory ambient environment.

Per ANSI/ESD S20.20, the test method for Product Qualification test is ANSI/ESD STM3.1, and for Compliance Verification is ESD TR53 which advises "Measurements should be made at the location where ESD sensitive items are to be ionized." A larger area may require additional ionizers. Per S20.20 the required limit for ionizer discharge time is user defined. Use Table to determine the number of ionizers to achieve ionization of area to be neutralized to meet your company's ESD control plan specified discharge times.

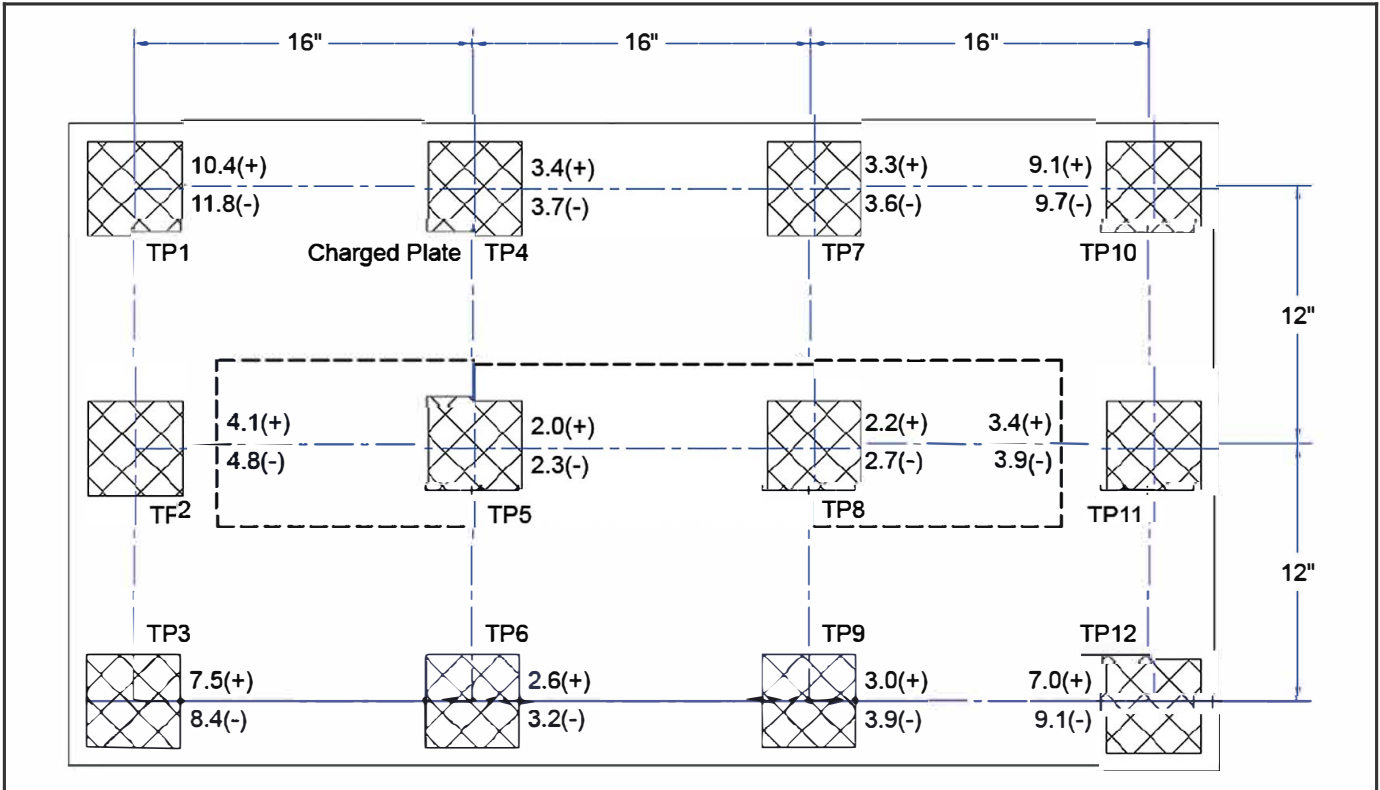

Figure 11. 60473, 60468 Neutralization (Discharge) Times at 100VAC, 50Hz input

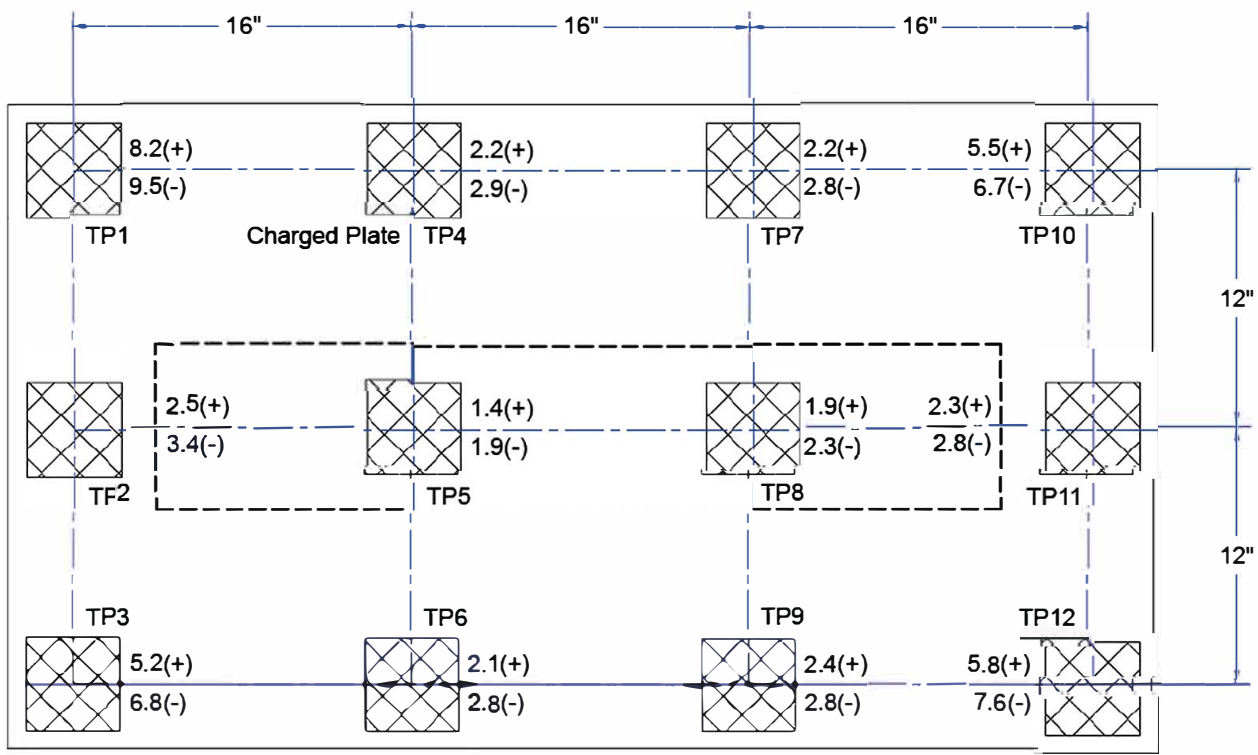

Figure 12. 60473, 60468 Neutralization (Discharge) Times at 120VAC, 60Hz input

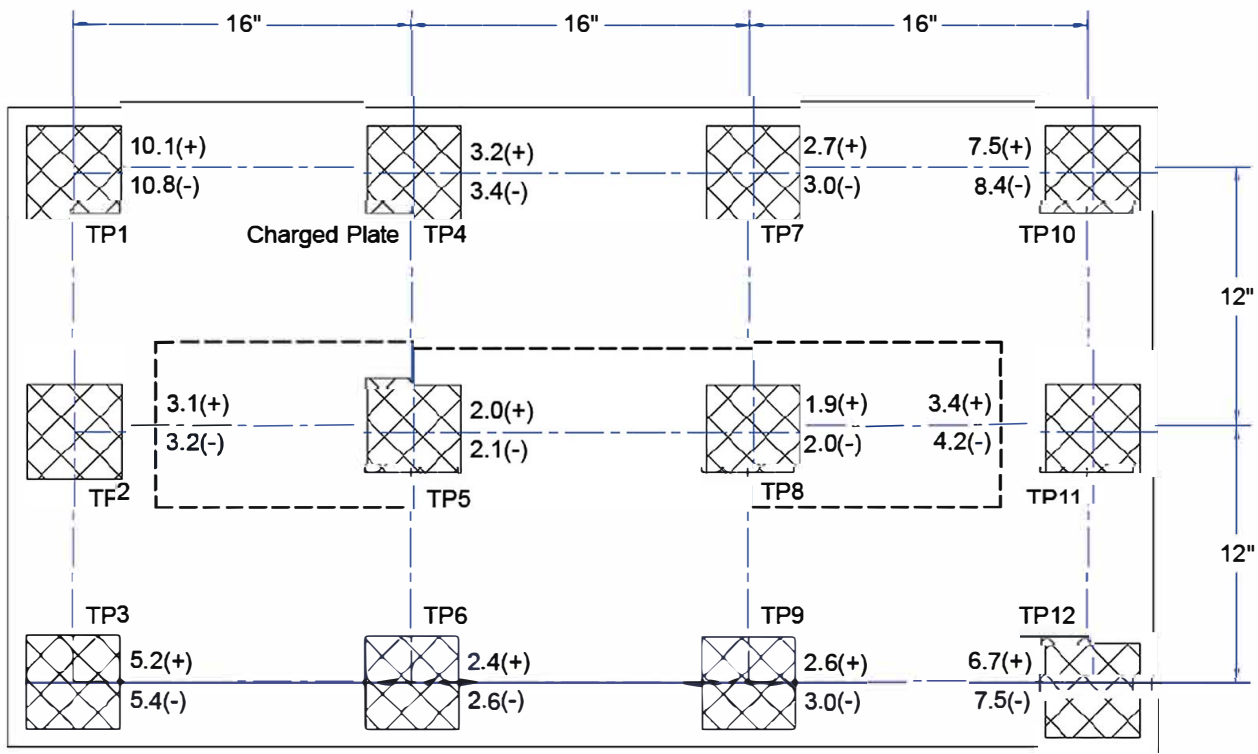

Figure 13. 60473, 60468 Neutralization (Discharge) Times at 220VAC, 50Hz input

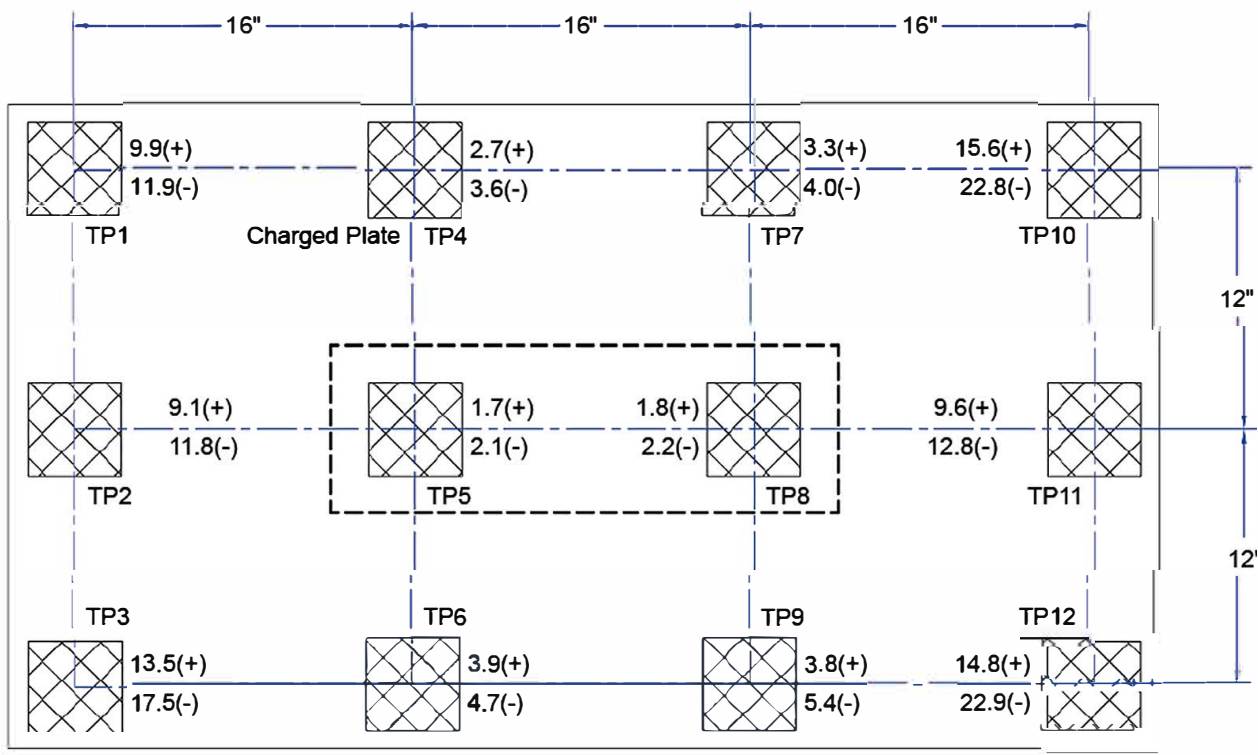

Figure 14. 60640, 60467 Neutralization (Discharge) Times at 100VAC, 50Hz input

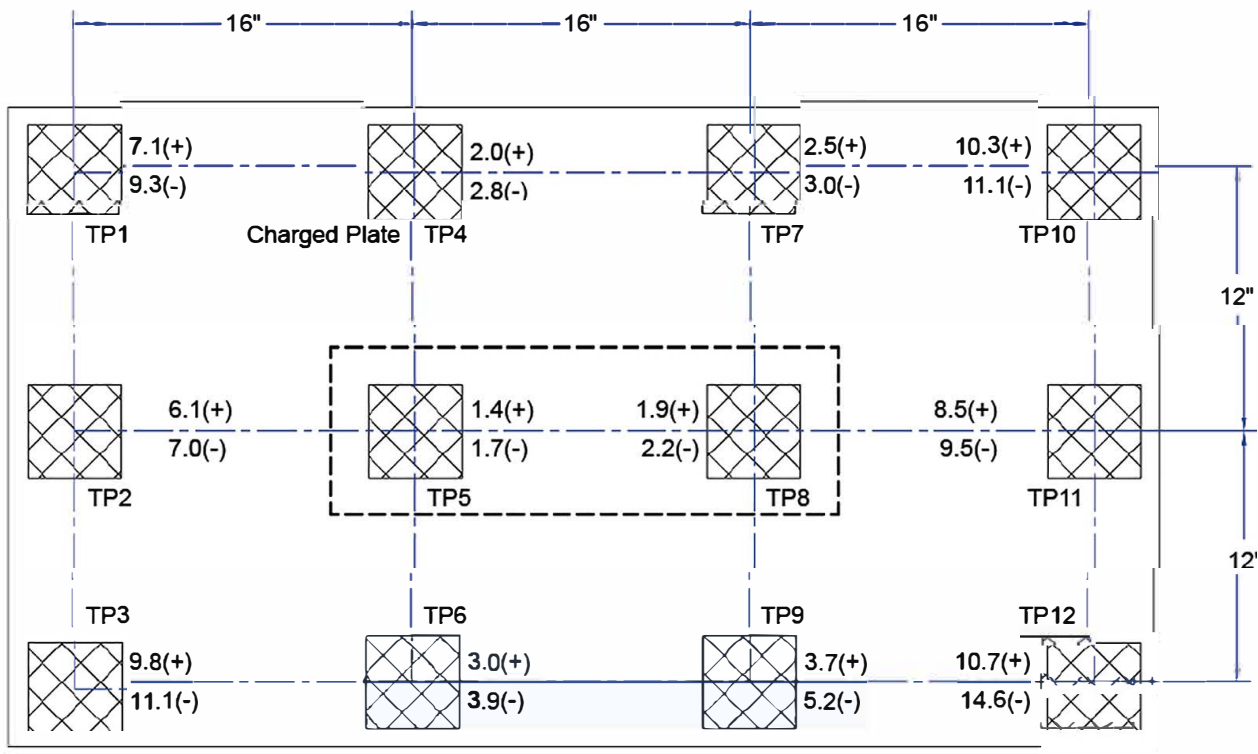

Figure 15. 60640, 60467 Neutralization (Discharge) Times at 120VAC, 60Hz input

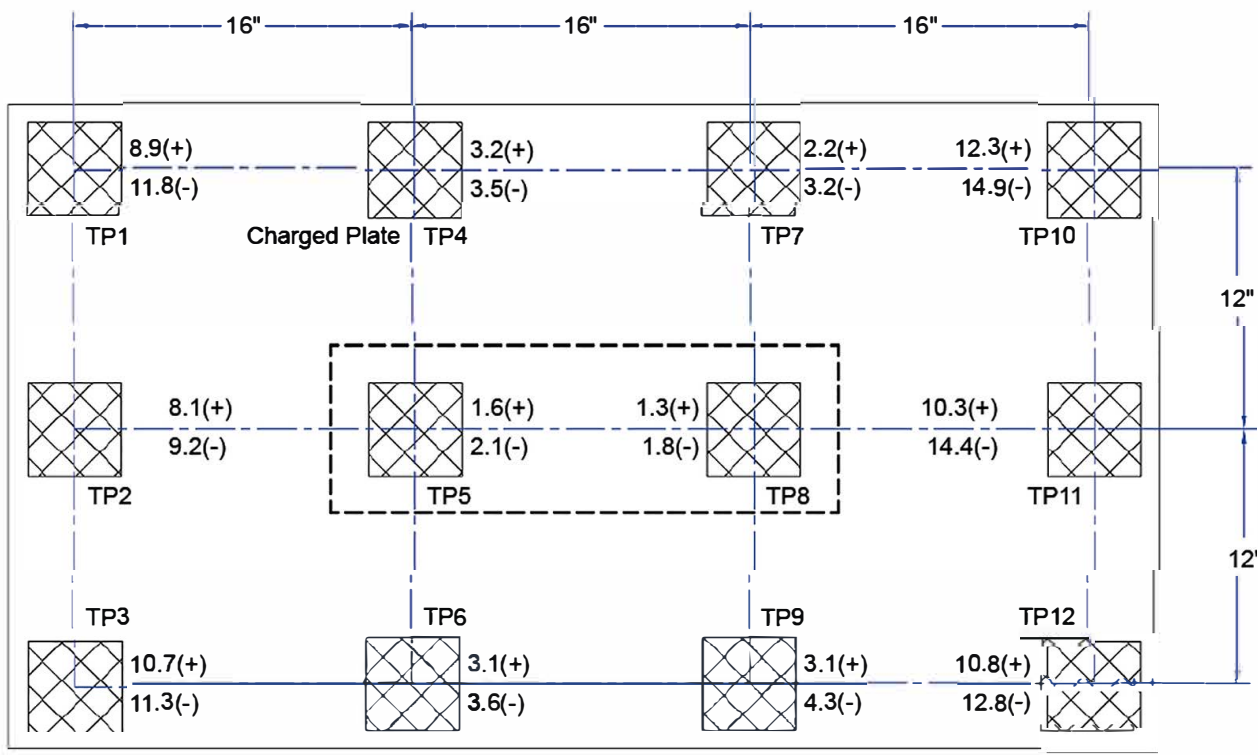

Figure 16. 60640, 60467 Neutralization (Discharge) Times at 220VAC, 50Hz input

Specifications

Typical positive and negative discharge times (1000V to 100V) measured using ANSI/ESD STM 3.1 are shown in the "Neutralization (Discharge) Times" section. The performance of the ionizer was measured with the unit positioned as shown, with the fan speed on high and without a filter.

Air Flow

60473, 60468 - Three speed fan (150 cfm - 300 cfm)
60640, 60467 - Three speed fan (100 cfm - 200 cfm)

Balance (offset voltage)

±10 Volts Typical
±20 Volts Maximum
(Temperature Range: 65°F - 80°F, RH: 15% - 65%)

Chassis

Powder coated steel

Dimensions

60473, 60468 - 3.9" H x 6.6" W x 37.3" L
(9.9cm H x 16.8cm W x 94.7 cm L)

60640, 60467 - 3.9" H x 6.6" W x 22.3" L
(9.9cm H x 16.8cm W x 56.6 cm L)

Emitter Points

.050" diameter
Made of pure tungsten for improved mechanical strength and ionization stability.

Fuse

400mA slow blow

High Voltage Power Supply

5.5kV DC nominal

Input Power

AC line power
Internally selectable for 100/120 VAC - 50/60Hz or
220/230 VAC - 50/60Hz

Ion Emission

Steady-state DC with sense feedback

Lights (60467, 60468 only)

700 lumen each
Cool white color
12 year estimated life expectancy (based on an average use of 10 hours per day)

Mounting

May be rigid-mounted or suspended from ceiling

Ozone

< 0.05 ppm

Weight

60473, 60468 - 10 lbs (4.5 kg)
60640, 60467 - 7 lbs (3.2 kg)

Health

There are no known health risks associated with our devices. The emitters work at about 4-6 kV and can create ozone, but there have been no significant measurement of ozone from our emitter sets, as all our existing units test well below the OSHA limit of 0.05 ppm ozone. For additional safety information, see "Dispelling an Old Myth" written by William Metz of Hewlett-Packard published in Evaluation Engineering Magazine, September 2001.

Accessories

60509 IONIZER MOTION SENSOR

Desco offers the [60509](#) Desco Ionizer Motion Sensor as an accessory for the Chargebuster® Overhead Ionizer. Use it to activate the ionizer when an operator is present and deactivate it when the workstation is vacant. The Ionizer Motion Sensor conserves energy and reduces ionizer maintenance.



Figure 17. Desco [60509](#) Ionizer Motion Sensor

Limited Warranty, Warranty Exclusions, Limit of Liability and RMA Request Instructions

See [Desco Terms and Conditions](#)