

Model 6220 DC Current Source Model 6221 AC and DC Current Source

User's Manual

622x-900-01 Rev. B / June 2005

Test Equipment Depot - 800.517.8431 - 99 Washington Street Melrose, MA 02176 - TestEquipmentDepot.com

KEITHLEY

A GREATER MEASURE OF CONFIDENCE

WARRANTY

Keithley Instruments, Inc. warrants this product to be free from defects in material and workmanship for a period of 1 year from date of shipment.

Keithley Instruments, Inc. warrants the following items for 90 days from the date of shipment: probes, cables, rechargeable batteries, diskettes, and documentation.

During the warranty period, we will, at our option, either repair or replace any product that proves to be defective.

To exercise this warranty, write or call your local Keithley representative, or contact Keithley headquarters in Cleveland, Ohio. You will be given prompt assistance and return instructions. Send the product, transportation prepaid, to the indicated service facility. Repairs will be made and the product returned, transportation prepaid. Repaired or replaced products are warranted for the balance of the original warranty period, or at least 90 days.

LIMITATION OF WARRANTY

This warranty does not apply to defects resulting from product modification without Keithley's express written consent, or misuse of any product or part. This warranty also does not apply to fuses, software, non-rechargeable batteries, damage from battery leakage, or problems arising from normal wear or failure to follow instructions.

THIS WARRANTY IS IN LIEU OF ALL OTHER WARRANTIES, EXPRESSED OR IMPLIED, INCLUDING ANY IMPLIED WARRANTY OF MERCHANTABILITY OR FITNESS FOR A PARTICULAR USE. THE REMEDIES PROVIDED HEREIN ARE BUYER'S SOLE AND EXCLUSIVE REMEDIES.

NEITHER KEITHLEY INSTRUMENTS, INC. NOR ANY OF ITS EMPLOYEES SHALL BE LIABLE FOR ANY DIRECT, INDIRECT, SPECIAL, INCIDENTAL OR CONSEQUENTIAL DAMAGES ARISING OUT OF THE USE OF ITS INSTRUMENTS AND SOFTWARE EVEN IF KEITHLEY INSTRUMENTS, INC., HAS BEEN ADVISED IN ADVANCE OF THE POSSIBILITY OF SUCH DAMAGES. SUCH EXCLUDED DAMAGES SHALL INCLUDE, BUT ARE NOT LIMITED TO: COSTS OF REMOVAL AND INSTALLATION, LOSSES SUSTAINED AS THE RESULT OF INJURY TO ANY PERSON, OR DAMAGE TO PROPERTY.

KEITHLEY

A GREATER MEASURE OF CONFIDENCE

Model 6220 DC Current Source
Model 6221 AC and DC Current Source
User's Manual

©2004, Keithley Instruments, Inc.
All rights reserved.
Cleveland, Ohio, U.S.A.
Second Printing, June 2005
Document Number: 622x-900-01 Rev. B

Manual Print History

The print history shown below lists the printing dates of all Revisions and Addenda created for this manual. The Revision Level letter increases alphabetically as the manual undergoes subsequent updates. Addenda, which are released between Revisions, contain important change information that the user should incorporate immediately into the manual. Addenda are numbered sequentially. When a new Revision is created, all Addenda associated with the previous Revision of the manual are incorporated into the new Revision of the manual. Each new Revision includes a revised copy of this print history page.

Revision A (Document Number 622x-900-01)	June 2004
Revision B (Document Number 622x-900-01)	June 2005

The following safety precautions should be observed before using this product and any associated instrumentation. Although some instruments and accessories would normally be used with non-hazardous voltages, there are situations where hazardous conditions may be present.

This product is intended for use by qualified personnel who recognize shock hazards and are familiar with the safety precautions required to avoid possible injury. Read and follow all installation, operation, and maintenance information carefully before using the product. Refer to the manual for complete product specifications.

If the product is used in a manner not specified, the protection provided by the product may be impaired.

The types of product users are:

Responsible body is the individual or group responsible for the use and maintenance of equipment, for ensuring that the equipment is operated within its specifications and operating limits, and for ensuring that operators are adequately trained.

Operators use the product for its intended function. They must be trained in electrical safety procedures and proper use of the instrument. They must be protected from electric shock and contact with hazardous live circuits.

Maintenance personnel perform routine procedures on the product to keep it operating properly, for example, setting the line voltage or replacing consumable materials. Maintenance procedures are described in the manual. The procedures explicitly state if the operator may perform them. Otherwise, they should be performed only by service personnel.

Service personnel are trained to work on live circuits, and perform safe installations and repairs of products. Only properly trained service personnel may perform installation and service procedures.

Keithley products are designed for use with electrical signals that are rated Measurement Category I and Measurement Category II, as described in the International Electrotechnical Commission (IEC) Standard IEC 60664. Most measurement, control, and data I/O signals are Measurement Category I and must not be directly connected to mains voltage or to voltage sources with high transient over-voltages. Measurement Category II connections require protection for high transient over-voltages often associated with local AC mains connections. Assume all measurement, control, and data I/O connections are for connection to Category I sources unless otherwise marked or described in the Manual.

Exercise extreme caution when a shock hazard is present. Lethal voltage may be present on cable connector jacks or test fixtures. The American National Standards Institute (ANSI) states that a shock hazard exists when voltage levels greater than 30V RMS, 42.4V peak, or 60VDC are present. **A good safety practice is to expect that hazardous voltage is present in any unknown circuit before measuring.**

Operators of this product must be protected from electric shock at all times. The responsible body must ensure that operators are prevented access and/or insulated from every connection point. In some cases, connections must be exposed to potential human contact. Product operators in these circumstances must be trained to protect themselves from the risk of electric shock. If the circuit is capable of operating at or above 1000 volts, **no conductive part of the circuit may be exposed.**

Do not connect switching cards directly to unlimited power circuits. They are intended to be used with impedance limited sources. NEVER connect switching cards directly to AC mains. When connecting sources to switching cards, install protective devices to limit fault current and voltage to the card.

Before operating an instrument, make sure the line cord is connected to a properly grounded power receptacle. Inspect the connecting cables, test leads, and jumpers for possible wear, cracks, or breaks before each use.

When installing equipment where access to the main power cord is restricted, such as rack mounting, a separate main input power disconnect device must be provided, in close proximity to the equipment and within easy reach of the operator.

For maximum safety, do not touch the product, test cables, or any other instruments while power is applied to the circuit under test. ALWAYS remove power from the entire test system and discharge any capacitors before connecting or disconnecting ca-

bles or jumpers, installing or removing switching cards, or making internal changes, such as installing or removing jumpers.

Do not touch any object that could provide a current path to the common side of the circuit under test or power line (earth) ground. Always make measurements with dry hands while standing on a dry, insulated surface capable of withstanding the voltage being measured.

The instrument and accessories must be used in accordance with its specifications and operating instructions or the safety of the equipment may be impaired.

Do not exceed the maximum signal levels of the instruments and accessories, as defined in the specifications and operating information, and as shown on the instrument or test fixture panels, or switching card.

When fuses are used in a product, replace with same type and rating for continued protection against fire hazard.

Chassis connections must only be used as shield connections for measuring circuits, NOT as safety earth ground connections.

If you are using a test fixture, keep the lid closed while power is applied to the device under test. Safe operation requires the use of a lid interlock.

If a  screw is present, connect it to safety earth ground using the wire recommended in the user documentation.

The  symbol on an instrument indicates that the user should refer to the operating instructions located in the manual.

The  symbol on an instrument shows that it can source or measure 1000 volts or more, including the combined effect of normal and common mode voltages. Use standard safety precautions to avoid personal contact with these voltages.

The  symbol indicates a connection terminal to the equipment frame.

The **WARNING** heading in a manual explains dangers that might result in personal injury or death. Always read the associated information very carefully before performing the indicated procedure.

The **CAUTION** heading in a manual explains hazards that could damage the instrument. Such damage may invalidate the warranty.

Instrumentation and accessories shall not be connected to humans.

Before performing any maintenance, disconnect the line cord and all test cables.

To maintain protection from electric shock and fire, replacement components in mains circuits, including the power transformer, test leads, and input jacks, must be purchased from Keithley Instruments. Standard fuses, with applicable national safety approvals, may be used if the rating and type are the same. Other components that are not safety related may be purchased from other suppliers as long as they are equivalent to the original component. (Note that selected parts should be purchased only through Keithley Instruments to maintain accuracy and functionality of the product.) If you are unsure about the applicability of a replacement component, call a Keithley Instruments office for information.

To clean an instrument, use a damp cloth or mild, water based cleaner. Clean the exterior of the instrument only. Do not apply cleaner directly to the instrument or allow liquids to enter or spill on the instrument. Products that consist of a circuit board with no case or chassis (e.g., data acquisition board for installation into a computer) should never require cleaning if handled according to instructions. If the board becomes contaminated and operation is affected, the board should be returned to the factory for proper cleaning/servicing.

Table of Contents

1	Getting Started	
	Introduction	1-2
	User's Manual content and structure	1-2
	Capabilities and features	1-2
	General information	1-3
	Warranty information	1-3
	Contact information	1-3
	Safety symbols and terms	1-3
	Unpacking and inspection	1-3
	Options and accessories	1-4
	Front and rear panel familiarization	1-4
	Front panel summaries	1-4
	Rear panel summaries	1-8
	Heat sink and cooling vents	1-9
	Power-up	1-11
	Line power connection	1-11
	Source preset	1-12
	Disabling the front panel	1-12
	Menus	1-13
	CONFIG menus	1-13
	Direct access menus	1-13
	Editing controls	1-14
	Source and compliance editing	1-14
	Menu navigation	1-14
	Password	1-16
	Remote interface	1-17
	Error and status messages	1-17
	Default settings	1-18
	Save and restore setups	1-18
	Select power-on setup	1-19
	SCPI programming	1-19
	Optional command words	1-19
	Query commands	1-19

2	Output Connections	
	Output connectors	2-2
	Triax connector	2-2
	Ground points	2-3
	LO and GUARD banana jacks	2-3
	INTERLOCK	2-4
	Output configurations	2-5
	Triax inner shield	2-6
	Triax output low	2-7
	Guards	2-8
	Triax Cable Guard	2-8
	Floating the current source	2-9
	Connections to DUT	2-9
	Supplied triax cable	2-9
	Basic connections	2-10
	Shields and guarding	2-10
	Using a test fixture	2-12
3	DC Current Source Operation	
	Current source output capabilities	3-2
	Source ranges	3-2
	Compliance	3-3
	Output power (source or sink)	3-3
	Output response	3-5
	Setting source and compliance	3-8
	Source and compliance editing	3-8
	Autorange	3-11
	Source preset	3-12
	Sourcing current	3-12
	Remote programming – source output commands	3-15
	Applications	3-16
4	Sweeps	
	Sweep overview	4-2
	Linear staircase sweep	4-2
	Logarithmic staircase sweep	4-2
	Custom sweep	4-2
	Sweep characteristics	4-4
	Custom sweep editing	4-4
	Using auto-copy with custom sweeps	4-4
	Source ranging	4-4
	Sweep delay	4-5

Front panel sweep operation	4-5
Using the sweep configuration menu	4-5
Performing a staircase sweep	4-6
Performing a custom sweep	4-7
Remote sweep operation	4-8
Running a staircase sweep	4-9
Running a custom sweep	4-10
SCPI commands — sweeps	4-11

5 **Delta, Pulse Delta, and Differential Conductance**

Operation overview	5-2
Test systems	5-4
Keithley instrumentation requirements	5-4
System configurations	5-4
System connections	5-5
DUT test connections	5-8
Configuring communications	5-9
Triggering sequence	5-10
Readings	5-11
Display readings	5-11
Measurement units	5-11
Read commands	5-13
Delta	5-13
Model 622x measurement process	5-13
Configuration settings	5-15
Operation	5-16
Setup and arm commands	5-19
Pulse Delta	5-21
Model 6221 measurement process	5-21
Pulse Delta outputs	5-22
Configuration settings	5-26
Operation	5-29
Setup commands	5-32
Differential Conductance	5-34
Model 622x measurement process	5-34
Configuration settings	5-37
Operation	5-38
Setup and arm commands	5-41

6 Averaging Filter, Math, and Buffer

Averaging filter	6-2
Averaging filter characteristics	6-2
Filter setup and control	6-4
Remote programming – Averaging filter	6-4
Math	6-5
$mX+b$ and $m/X+b$ (reciprocal)	6-5
Configuring $mX+b$ and $m/X+b$	6-6
Remote programming – Math	6-6
Buffer	6-7
Buffer characteristics	6-7
Storing readings	6-8
Recall	6-8

7 Wave Functions (6221 Only)

Wave function overview	7-2
Setting waveform parameters	7-3
Ranging	7-3
Frequency	7-4
Offset	7-4
Duty cycle	7-5
Phase marker	7-6
Duration	7-7
Externally triggered waveforms	7-7
Front panel wave function operation	7-8
Using the wave function menu	7-8
Generating a sine wave	7-10
Generating an arbitrary waveform	7-11
Remote wave function operation	7-12
Programming sine waves	7-13
Programming arbitrary waveforms	7-14
SCPI commands — wave functions	7-15

A Specifications

B SCPI Tables (Abridged)

List of Illustrations

1 Getting Started

Figure 1-1	Models 6220 and 6621 front panels	1-5
Figure 1-2	Model 622x rear panel	1-8
Figure 1-3	Menu editing keys	1-14

2 Output Connections

Figure 2-1	Triax connector and grounds points	2-2
Figure 2-2	LO and GUARD banana jacks	2-3
Figure 2-3	INTERLOCK	2-4
Figure 2-4	Output configurations – triax inner shield connected to Output Low	2-5
Figure 2-5	Output configurations – triax inner shield connected to Cable Guard	2-6
Figure 2-6	Basic connections to DUT	2-10
Figure 2-7	Noise shield	2-10
Figure 2-8	Safety shield	2-11
Figure 2-9	Cable Guard connections – triax inner shield connected to Cable Guard	2-11
Figure 2-10	Connections for noise shield, safety shield, and guarding	2-12

3 DC Current Source Operation

Figure 3-1	Output boundaries (source and sink)	3-5
Figure 3-2	Source and compliance editing – Model 6220	3-8
Figure 3-3	Source and compliance editing – Model 6221	3-10

4 Sweeps

Figure 4-1	Comparison of sweep types	4-3
------------	---------------------------------	-----

5 Delta, Pulse Delta, and Differential Conductance

Figure 5-1	Delta, Pulse Delta, and Differential Conductance measurements	5-3
Figure 5-2	System configurations for Delta, Pulse Delta, and Differential Conductance	5-5
Figure 5-3	System connections – stand-alone operation	5-6
Figure 5-4	System connections – PC control of Model 622x	5-7
Figure 5-5	Guarded test connections	5-8
Figure 5-6	Delta measurement technique	5-14
Figure 5-7	Pulse Delta 3-point measurement technique	5-21
Figure 5-8	Pulse timing	5-24
Figure 5-9	Pulse sweep output examples	5-25
Figure 5-10	Differential Conductance measurement process	5-35

6 Averaging Filter, Math, and Buffer

Figure 6-1	Buffer recall	6-9
------------	---------------------	-----

7

Wave Functions (6221 Only)

Figure 7-1	Offset example	7-4
Figure 7-2	Duty cycle	7-5
Figure 7-3	Phase marker	7-6

List of Tables

3	DC Current Source Operation	
Table 3-1	Source ranges and maximum outputs	3-2
Table 3-2	DC output commands	3-15
4	Sweeps	
Table 4-1	Sweep configuration menu	4-5
Table 4-2	Sweep example parameters	4-8
Table 4-3	Staircase sweep commands (linear and logarithmic)	4-11
Table 4-4	Custom (list) sweep commands	4-12
5	Delta, Pulse Delta, and Differential Conductance	
Table 5-1	Measurement unit commands	5-12
Table 5-2	Delta commands	5-20
Table 5-3	Pulse Delta commands	5-33
Table 5-4	Differential Conductance commands	5-42
6	Averaging Filter, Math, and Buffer	
Table 6-1	Average filter types	6-2
Table 6-2	Averaging filter commands	6-5
Table 6-3	Math commands	6-6
Table 6-4	Buffer commands	6-9
7	Wave Functions (6221 Only)	
Table 7-1	Wave function characteristics	7-2
Table 7-2	Wave function configuration menu	7-8
Table 7-3	Waveform example parameters	7-12
Table 7-4	Waveform function commands	7-15
B	SCPI Tables (Abridged)	
Table B-1	Calculate command summary	B-2
Table B-2	Display command summary	B-2
Table B-3	Format command summary	B-3
Table B-4	Output command summary	B-3
Table B-5	Sense command summary	B-3
Table B-6	Source command summary	B-4
Table B-7	Status command summary	B-7
Table B-8	System command summary	B-8
Table B-9	Trace command summary	B-9
Table B-10	Trigger command summary	B-10
Table B-11	Units command summary	B-10

1 Getting Started

Section 1 topics

Introduction, page 1-2

User's Manual content and structure, page 1-2

Capabilities and features, page 1-2

General information, page 1-3

Warranty information, page 1-3

Contact information, page 1-3

Safety symbols and terms, page 1-3

Unpacking and inspection, page 1-3

Options and accessories, page 1-4

Front and rear panel familiarization, page 1-4

Front panel summaries, page 1-4

Rear panel summaries, page 1-8

Heat sink and cooling vents, page 1-9

Power-up, page 1-11

Line power connection, page 1-11

Source preset, page 1-12

Disabling the front panel, page 1-12

Menus, page 1-13

CONFIG menus, page 1-13

Direct access menus, page 1-13

Editing controls, page 1-14

Source and compliance editing, page 1-14

Menu navigation, page 1-14

Password, page 1-16

Remote interface, page 1-17

Error and status messages, page 1-17

Default settings, page 1-17

Save and restore setups, page 1-18

Select power-on setup, page 1-18

SCPI programming, page 1-17

Optional command words, page 1-19

Query commands, page 1-19

NOTE The information in this section is an abbreviated version of the information in Section 1 of the Reference Manual. Refer to Section 1 of the Reference Manual for complete details and additional information that is not provided in this manual.

Introduction

User's Manual content and structure

This User's Manual is provided as a hardcopy and is also provided on the supplied Product Information CD in PDF format. The User's Manual is an abbreviated version of the operation sections of the Reference Manual. The seven sections of the User's Manual correspond (in abbreviated form) to the first seven sections of the Reference Manual.

The Reference Manual is on the Product Information CD in PDF format. Refer to the Reference Manual for complete information.

Capabilities and features

- Source \pm DC current from 0.1pA to 105mA.
- Voltage compliance limit from 0.1V to 105V in 10mV steps.
- 11W, four-quadrant sink or source operation (duty cycle limitation for high power sink).
- Analog filter to slow down output response.
- Triax cable guarding to optimize output response speed and reduce leakage currents in high impedance test circuits.
- Banana jack guard output for voltage measurements.
- Sweep functions: linear staircase, logarithmic staircase, and custom.
- Waveform functions (6221 only): Sine, square, ramp, and arbitrary function generator.
- Five user-saved setups.
- Delta testing when used with the Keithley Model 2182 or 2182A:
 - **Delta** – Uses a square wave output and a 3-point measurement algorithm to cancel the effects of thermal EMFs.
 - **Pulse Delta (6221 and 2182A only)** – Provides a pulse output and a 3-point (or 2-point) measurement algorithm for testing of temperature sensitive Device Under Test (DUT).
 - **Differential Conductance** – Uses a differential current output and a 3-point moving average algorithm to perform differential measurements.
 - Buffer storage and recall for up to 65,536 delta readings
 - Averaging filtering for delta readings
- Supported remote interfaces: **Model 6220**: GPIB and RS-232.
Model 6221: GPIB, RS-232, and Ethernet.
- KI-220 language – DDC commands to emulate Model 220 operation.

General information

Warranty information

Warranty information is located at the front of this manual. Should your Model 622x require warranty service, contact the Keithley representative or authorized repair facility in your area for further information. When returning the instrument for repair, be sure to fill out and include the service form at the back of this manual to provide the repair facility with the necessary information.

Contact information

Worldwide phone numbers are listed at the front of this manual.

Safety symbols and terms

The following symbols and terms may be found on the instrument or used in this manual:

If a  screw is present, connect it to safety earth ground using the wire recommended in the user documentation.

The  symbol on an instrument indicates that the user should refer to the operating instructions located in the manual.

The  symbol on an instrument shows that it can source or measure 1000 volts or more, including the combined effect of normal and common mode voltages. Use standard safety precautions to avoid personal contact with these voltages.

The  symbol indicates a connection terminal to the equipment frame.

The **WARNING** heading used in this manual explains dangers that might result in personal injury or death. Always read the associated information very carefully before performing the indicated procedure.

The **CAUTION** heading used in this manual explains hazards that could damage the instrument. Such damage may invalidate the warranty.

Unpacking and inspection

Inspection for damage

The Model 622x was carefully inspected electrically and mechanically before shipment. After unpacking all items from the shipping carton, check for any obvious signs of physical damage that may have occurred during transit. (There may be a protective film over the display lens, which can be removed.) Report any damage

to the shipping agent immediately. Save the original packing carton for possible future shipment. Before removing the Model 622x from the bag, observe the following handling precautions.

Handling precautions

- Always grasp the Model 622x by the covers.
- After removing the Model 622x from its anti-static bag, inspect it for any obvious signs of physical damage. Report any such damage to the shipping agent immediately.
- When the Model 622x is not installed and connected, keep the unit in its anti-static bag and store it in the original packing carton.

Package content

The following items are included with every Model 622x order:

- Model 622x current source with line cord.
- Protective triax Shield/Cap (CAP-28-1).
- 237-ALG-2 Triax cable terminated with alligator clips on one end.
- Model 8501 Trigger Link cable.
- CA-351 null-modem serial cable.
- CA-180-3A Ethernet cross-over cable (Model 6221 only).
- Accessories as ordered.
- Certificate of calibration.
- Model 622x User's Manual (P/N 622x-900-00).
- Product Information CD-ROM that contains PDFs of the User's and Reference Manuals.

Options and accessories

The various options and accessories that are available from Keithley for the Model 622x are listed and explained in Section 1 of the Reference Manual.

Front and rear panel familiarization

Front panel summaries

The front panels of the Models 6220 and 6221 are shown in [Figure 1-1](#). The descriptions of the front panel controls follow [Figure 1-1](#).

Many of the keys that are used to select a function or operation are also used for configuration by first pressing the **CONFIG** key. For example, to configure a sweep, press **CONFIG** and then **SWP**.

Figure 1-1
Models 6220 and 6621 front panels

Model 6220:

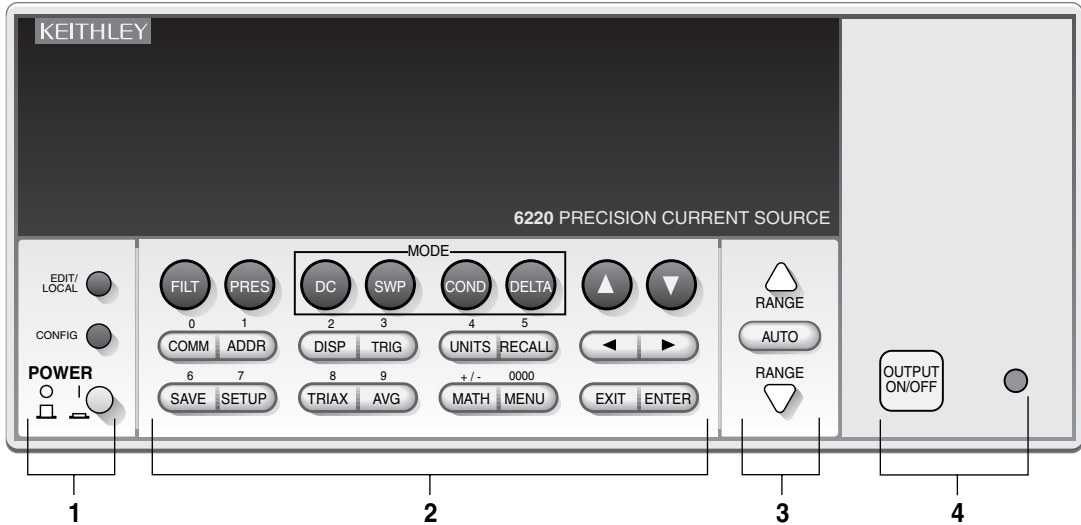

Model 6221:

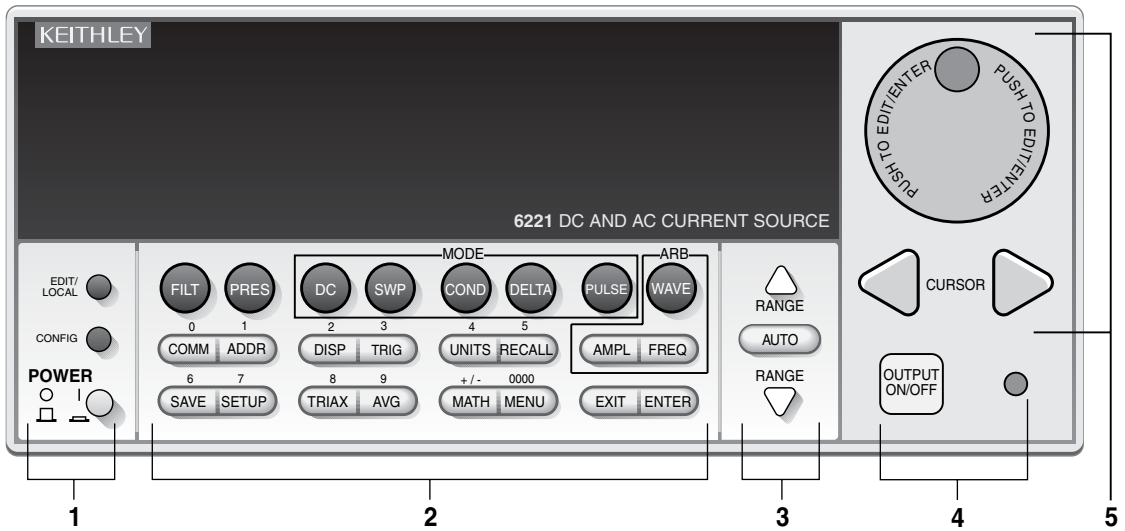

1 Special keys and power switch:

EDIT/LOCAL	Dual function – While in local, EDIT selects the source editing mode. While in remote, LOCAL cancel the remote mode.
CONFIG	Use to configure a function or operation.
POWER	Power switch – In position turns 622x on (I), out position turns it off (O).

2 Function and operation keys:

Top Row

FILT	Enables/disables analog filter.
PRES	Enables/disables the pre-set source value. Press CONFIG > PRES to set the source value for PRES.
DC	Selects DC current source function.
SWP	Arms the sweep function. Press CONFIG > SWP to configure the sweep.
COND	Arms Differential Conductance. Press CONFIG > COND to configure Differential Conductance.
DELTA	Arms Delta. Press CONFIG > DELTA to configure Delta.

6220:

△	Increments value.
▽	Decrements value.

6221:

PULSE	Arms Pulse Delta. Press CONFIG > PULSE to configure Pulse Delta.
WAVE	Arms Wave mode. Press CONFIG > WAVE to configure Wave.

Middle Row

COMM	Configures communications: GPIB, RS-232, or Ethernet (6221). Can also press CONFIG > COMM to configure communications.
ADDR	Sets GPIB address.
DISP	Turns off display. Press LOCAL or DISP to turn display back on.
TRIG	Starts a sweep, delta, or wave (6221) test, or causes a manual trigger event. Press CONFIG > TRIG to configure triggers.
UNITS	Use to select measurement units for a delta function. Can also press CONFIG > UNITS to select measurement units.
RECALL	Displays buffer readings and statistics. Press CONFIG > RECALL to access menu to clear the buffer.

6220:

◀	Moves cursor (blinking digit or menu item) to the left.
▶	Moves cursor (blinking digit or menu item) to the right.

6221:

AMPL	Sets the amplitude for the Wave function. Can also press CONFIG > AMPL to set the amplitude. When in a menu, use this key to move the cursor to the left.
FREQ	Sets the frequency for the Wave function. Can also press CONFIG > FREQ to set the frequency. When in a menu, use this key to move the cursor to the right.

Bottom Row

SAVE	Saves up to five instrument setups for future recall, and selects power-on setup.
SETUP	Restores a default setup (preset or *RST) or a user saved setup.
TRIAx	Configures triax connector: Inner shield and Output Low. Can also press CONFIG > TRIAX to configure triax connector.
AVG	Enables/disables averaging filter. Press CONFIG > AVG to configure averaging filter.
MATH	Enables/disable math. Press CONFIG > MATH to configure math.
MENU	Accesses the main menu for calibration, self-tests, serial number, and beeper control.
EXIT	Cancels selection, backs out of menu structure.
ENTER	Accepts selection, moves to next choice or exits menu.

3 Range keys:

\triangle and ∇	Dual function – Selects the next higher or lower source range. When in a menu, these keys increment or decrement values.
AUTO	Enables or disables source autorange.

4 Output control and LED status indicator:

OUTPUT ON/OFF	Turns source output on or off. For the 6221, press CONFIG > OUTPUT to set the output response for the Model 6221.
LED indicator	Turns on when output is on. Blinks if source goes into compliance.

5 Rotary knob and CURSOR keys (Model 6221):

When in source edit, use CURSOR keys for cursor control and rotate the knob to change a source or compliance value. The rotary knob can also be used to enable or disable the source EDIT mode.

When in a menu, use the CURSOR keys or rotary knob for menu item cursor control. When displaying a menu value, use the CURSOR keys for cursor control and rotate the knob to change the value. Pressing the knob opens a menu item or selects a menu option or value.

6 Display annunciators (not shown):

EDIT	Unit is in the source editing mode.
ERR	Questionable reading or invalid cal step.
REM	Unit in remote mode.
TALK	Unit addressed to talk.
LSTN	Unit addressed to listen.
SRQ	Service request.
FILT	Analog filter or Averaging filter is enabled.
MATH	Math is enabled.
AUTO	Auto source range selected.
ARM	Sweep or delta function armed and ready to run.
TRIG	External triggering selected.
* (asterisk)	Readings being stored in buffer.
SMPL	Blinks for every other reading acquired from the Model 2182/2182A.

Rear panel summaries

The rear panel of the Models 622x is shown in [Figure 1-2](#). The Model 6221 rear panel is shown, but the Model 6220 is identical except it does not have the Ethernet connector. The descriptions of the rear panel components follow [Figure 1-2](#).

Figure 1-2
Model 622x rear panel

NOTE The rear panels of the Model 6220 and 6221 are the same, except the Model 6220 does not have an Ethernet connector (3).

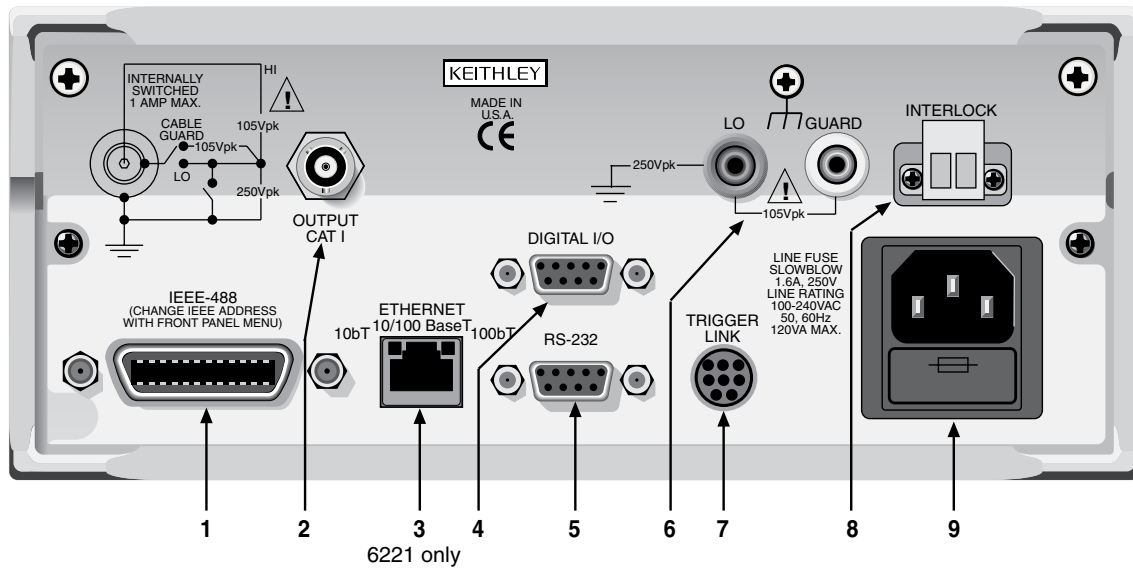

1 IEEE-488

Connector for IEEE-488 (GPIB) operation. Use a shielded cable, such as the Model 7007-1 or 7007-2.

2 OUTPUT

3-lug female triax connector for current source output. Mates to the supplied triax cable (237-ALG-2). Will also mate to any triax cable terminated with a 3-slot male triax connector.

3 ETHERNET

RJ45 female connector for Ethernet operation. Use an RJ45 male/male cable for connection. Two status LEDs are located at the top of the connector. These LEDs indicate status of the Ethernet (see Section 10 of the Reference Manual for details).

4 DIGITAL I/O

Male DB-9 connector. Four pins for digital output, one pin for Start of Test (SOT) trigger, and one for external voltage (VEXT) input.

5 RS-232

Female DB-9 connector:

- For RS-232 operation, use a straight-through (not null modem) DB-9 shielded cable for connection to the PC.
- For Delta, Pulse Delta, and Differential Conductance, use the supplied serial cable (CA-351) for connections between the Model 622x and the Model 2182/2182A.

6 LO and GUARD

Banana safety jacks for output low and banana jack Guard.

7 TRIGGER LINK

Eight-pin micro-DIN connector for sending and receiving trigger pulses among connected instruments. Use a trigger link cable (Model 8501) for connections.

8 INTERLOCK

Interlock connector – Provides two screw terminals for connection to an interlock switch. When the interlock switch is closed, the OUTPUT of the 622x is enabled, allowing it to be turned on. When the interlock switch is opened, the OUTPUT is disabled (OUTPUT cannot be turned on and will turn off if it was on).

9 Power module

Contains the AC line receptacle and power line fuse. The instrument can operate on line voltages of 100V to 240VAC at line frequencies of 50 or 60Hz.

Heat sink and cooling vents

The Model 622x uses a heat sink and three cooling vents to dissipate heat. The right side of the case is cut out to expose the black, finned heat sink. Cooling vents are provided on both sides of the case and on the top cover.

The heat sink could get hot enough to cause burns. Even if the instrument is turned off, you should assume that the heat sink is still hot as it takes considerable time for it to cool off.

WARNING When handling the Model 622x, **NEVER** touch the heat sink located on the right side of the case. This heat sink could be hot enough to cause burns.

CAUTION **NEVER** place a container of liquid (e.g., water, coffee, etc.) on the top cover. If it spills, the liquid will enter the case through the vents and cause severe damage.

Excessive heat could damage the Model 622x and at the very least, degrade its performance. The Model 622x must be operating in an environment where the ambient temperature does not exceed 50°C.

CAUTION To prevent damaging heat build-up and thus ensure specified performance, adhere to the following precautions:

- The heat sink must be kept free of dust, dirt, and contaminants, since its ability to dissipate heat could become impaired.
- The cooling vents must be kept free of any obstructions. **DO NOT** place any objects on the top cover. Even partial blockage could impair proper cooling.
- **DO NOT** position any devices adjacent to the Model 622x that force air (heated or unheated) into or onto its cooling vents or surfaces. This additional airflow could compromise accuracy performance.
- For bench top use, the Model 622x can be placed on a hard surface that is at ambient temperature. The feet of the Model 622x will raise the chassis off the surface to allow adequate ventilation under the unit. **DO NOT** use the Model 622x on a soft, compliant surface, like a carpet.
- The Model 622x can be set on top of another instrument that is dissipating heat, but additional spacing is required. In order to maintain full power capability, 1.75" of spacing is required. The feet of the Model 622x only provide 0.625" (5/8") of spacing.
- Rack mounting requires 1U of vertical spacing at the top and bottom of the Model 622x. 1U is a standard vertical spacing unit and is equal to 1.75". The typical distance between the mounting screw holes on the rack rails is 0.125" (1/8").
- When rack mounting the Model 622x, make sure there is adequate airflow around the sides and top to ensure proper cooling. Adequate airflow enables air temperatures within approximately one inch of the Model 622x surfaces to remain within specified limits under all operating conditions.

- **Rack mounting high power dissipation equipment adjacent to the Model 622x could cause excessive heating to occur. The specified ambient temperature must be maintained around the surfaces of the Model 622x to specified accuracies.**
- **A good measure to ensure proper cooling in rack situations with convection cooling only is to place the hottest equipment (e.g., power supply) at the top of the rack. Precision equipment, such as the Model 622x, should be placed as low as possible in the rack where temperatures are coolest. Adding space panels below the Model 622x will help ensure adequate air flow.**

Power-up

WARNING When handling the Model 622x, **NEVER** touch the heat sink located on the right side of the case. This heat sink could be hot enough to cause burns.

Line power connection

Follow the procedure below to connect the Model 622x to line power and turn on the instrument. The current source operates from a line voltage of 100 to 240V at a frequency of 50 or 60Hz. Line voltage and line frequency are automatically sensed. There are no switches to set. Make sure the operating voltage in your area is compatible.

CAUTION **Operating the instrument on an incorrect line voltage may cause damage to the instrument, possibly voiding the warranty.**

1. Before plugging in the power cord, make sure that the front panel power switch is in the off (O) position.
2. Connect the female end of the supplied power cord to the AC receptacle on the rear panel. Connect the other end of the power cord to a grounded AC outlet.

WARNING The power cord supplied with the Model 622x contains a separate ground wire for use with grounded outlets. When proper connections are made, instrument chassis is connected to power line ground through the ground wire in the power cord. Failure to use a grounded outlet may result in personal injury or death due to electric shock.

3. Turn on the instrument by pressing the front panel power switch to the on (I) position.

Source preset

The **PRES** key can be used to set the source to a preset value. When the **PRES** key is pressed, the source will set to the preset value ("PRES" message displayed). When the **PRES** key is pressed again, the unit will return to the original source value. See "[Source preset](#)" on [page 3-12](#) for details on setting the preset value.

Disabling the front panel

The front panel (display and most controls) can be disabled to allow testing on light sensitive devices; eliminate step-to-step timing jitter for Sweeps, Delta, and Differential Conductance; and increase system speed.

The front panel can be disabled by pressing the **DISP** key. The following message will be briefly displayed before the display shuts off:

FRONT PANEL DISABLED

Press LOCAL or DISP to resume.

As indicated in the displayed message, press **LOCAL** or **DISP** to enable the front panel.

Remote programming – Use the following command to control the front panel:

```
DISPlay:ENABle <b>
```

- ‘ Enable or disable the front panel.
- ‘ = ON or OFF.
- ‘ Default setting is front panel ON.

Step-to-step timing jitter

For Sweeps, Delta, and Differential Conductance, step-to-step timing may jitter as much as 1ms. This jitter can be eliminated by disabling the front panel.

If the display is disabled while a Sweep, Delta, or Differential Conductance is running, a 2-second pause in continuous operation will occur. To avoid this pause, disable the front panel before arming the Sweep, Delta or Differential Conductance test. Keep in mind that remote programming must then be used to arm and start the test.

Menus

Many aspects of operation are configured through menus. A direct access menu can be opened by pressing a single key, and other menus require that the **CONFIG** key be pressed before pressing another key.

CONFIG menus

NOTE “Press **CONFIG** > Press **SWP**” is an example of a key-press sequence. To open the menu, press the **CONFIG** key and then the **SWP** key.

Models 6220 and 6221:

CONFIG > **SWP** opens CONFIGURE SWEEPS menu ([Section 4](#)).
CONFIG > **COND** opens DIFF CONDUCTANCE menu ([Section 5](#)).
CONFIG > **DELTA** opens CONFIGURE DELTA menu ([Section 5](#)).
CONFIG > **TRIG** opens CONFIGURE TRIGGER menu (Section 8 of the 622x Reference Manual).
CONFIG > **RECALL** opens CLEAR BUFFER? menu ([Section 6](#)).
CONFIG > **MATH** opens CONFIGURE MATH menu ([Section 6](#)).

Model 6221 only:

CONFIG > **PULSE** opens CONFIG PULSE DELTA menu ([Section 5](#)).
CONFIG > **WAVE** opens CONFIGURE WAVEFORM menu ([Section 7](#)).
CONFIG > **OUTPUT** opens OUTPUT RESPONSE menu ([Section 3](#)).

Direct access menus

NOTE All of the following keys to open direct access menus (except **RECALL**) can also be opened by first pressing the **CONFIG** key.

Models 6220 and 6221:

COMM opens COMMUNICATIONS SETUP menu ([page 1-17](#)).
ADDR opens ADDRESS = (value) menu for GPIB.
UNITS opens READING UNITS menu ([Section 3](#)).
RECALL opens menu for stored readings and statistics ([Section 6](#)).
SAVE opens SAVED SETUP MENU ([page 1-18](#)).
SETUP opens RESTORE SETUP menu ([page 1-18](#)).
TRIAx opens CONFIGURE TRIAX menu ([Section 2](#)).
MENU opens MAIN MENU (see “[MAIN menu](#)” below).

Return to [Section 1 topics](#)

Model 6221:

AMPL opens menu to set AMPL: (value) ([Section 7](#)).

FREQ opens menu to set FREQ (frequency) ([Section 7](#)).

MAIN menu

The MAIN MENU is a direct access menu that is opened by pressing the **MENU** key. Menu items include CAL, TEST, SERIAL#, and BEEPER. See Section 1 of the Reference Manual for more information on these MAIN MENU items.

Editing controls

Source and compliance editing

When the Model 622x is in the edit mode (EDIT annunciator on), the editing controls are used to set source and compliance values. The typical way to enter the edit mode is to press the **EDIT** key. Details on “[Source and compliance editing](#)” are provided on [page 3-8](#).

Menu navigation

When the Model 622x is not in the edit mode (EDIT annunciator off), the editing controls (see [Figure 1-3](#)) are used to navigate menus to make selections and/or set values.

Figure 1-3
Menu editing keys

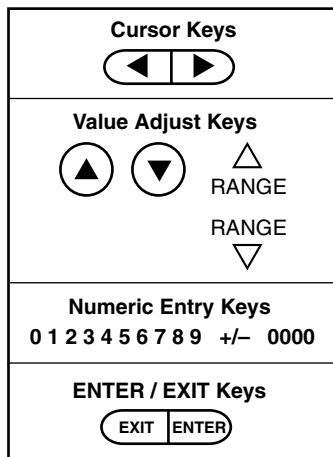
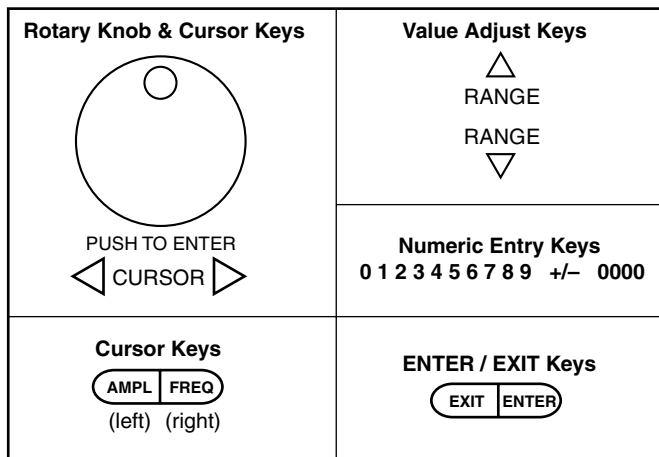
6220 Editing Keys:**6221 Editing Keys:**

Model 6220 menu navigation

After entering a menu structure, use the editing keys as follows:

Selecting menu items

1. Use the **Cursor Keys** to place the blinking cursor on a menu item to be opened or selected.
2. Press the **ENTER** key to select an item or open a sub menu.
3. Use the **EXIT** key to cancel a change or back out of the menu structure.

Setting a value

There are two ways to adjust a value: value adjust or numeric entry. Both methods use the following editing techniques:

- To set a value to zero, press the **0000** numeric entry key.
- To toggle the polarity of a value, press the **+/-** numeric entry key.

Value adjust method:

1. Use the **Cursor Keys** to place the blinking cursor on the digit to be edited.
2. Use the Value Adjust Keys to increment or decrement the value of the digit. Digit(s) to the left may also change as the edited value is changed beyond "9" or under "0".
3. Repeat steps 1 and 2 as needed to set the desired value.
4. Press **ENTER** to select the value. Pressing **EXIT** will cancel the change.

Numeric entry method:

1. Use the **Cursor Keys** to place the blinking cursor on the most significant digit to be edited.
2. Key in a digit by pressing a **Numeric Entry Key** (0 to 9), The cursor moves to the next digit on the right.
3. Repeat step 2 as needed to set the desired value.
4. Press **ENTER** to select the value. Pressing **EXIT** will cancel the change.

Model 6221 menu navigation

Editing for the Model 6221 is basically the same as editing for the Model 6220, except for the following differences:

- Cursor control is provided by the **Cursor Keys** located under the rotary knob.
- When at a menu level that requires an item to be selected, the **Rotary Knob** can also be used for cursor control. Turn the knob clockwise to move the cursor to the right, and turn it counter-clockwise to move the cursor to the left.
- With a value displayed, value adjust can be performed using the **Rotary Knob**. Turn it clockwise to increment a digit, and turn it counter-clockwise to decrement a digit.
- Pressing the **ROTARY KNOB** performs the same function as the **ENTER** key. Press the knob to select or open a menu item, or to select a displayed value.

Password

For remote programming, a user-defined password can be used to disable protected commands. Most Model 622x commands are protected. From the front panel, the password can be cleared using the following key-press sequence:

Press **COMM** > Select **PASSWORD** > Select **YES** to clear the password

See Section 10 of the Reference Manual for details on password.

Remote interface

For remote operation, one of the following interfaces can be used: GPIB, RS-232, and (for the Model 6221) Ethernet. When using the GPIB, the SCPI or KI-220 language can be used.

NOTE Interface selection and configuration can be performed from the **COMMUNICATIONS SETUP** menu, which is accessed by pressing the **COMM** key. All details on interface selection and configuration are provided in **Section 10** of the Reference Manual.

GPIB

At the factory, the GPIB (SCPI language) is the selected interface and the GPIB address is set to 12. Use the following key-press sequence to change the address:

Press **ADDR** > Set the address (**0 to 30**) > Press **ENTER**

RS-232

When the RS-232 interface is selected, the following defaults are initially set (but can be changed):

Baud rate: 19.2k

Terminator: LF (line feed)

Flow control: None

Eight data bits, one stop bit, and no parity are used for the RS-232. These settings are fixed and cannot be changed.

Ethernet (Model 6221 only)

The information for setting up the Ethernet is provided in Section 10 of the Reference Manual (see "Ethernet interface reference").

Error and status messages

Error and status messages are displayed momentarily. During operation and programming, you will encounter a number of front panel messages. Typical messages are either status or error type, as listed in Appendix B of the Reference Manual.

Default settings

The Model 622x can be restored to one of seven setup configurations: five user-saved setups, PRESET (bench defaults), and *RST (bus defaults). As shipped from the factory, the Model 622x powers up to the PRESET settings. PRESET settings provide a general purpose setup for front panel operation, while the *RST settings do the same for remote operation.

NOTE User setups cannot be saved or recalled while Wave, Sweep, Delta, Pulse Delta, or Differential Conductance is armed or running. Attempting to do so will generate error +413 Not allowed with mode armed.

A custom sweep cannot be saved as a user setup. Attempting to do so will generate error +528 Cannot save CUSTOM sweep setup.

Source preset values are not saved as part of a user setup.

See Section 1 of the Reference Manual for more information on “Default settings” including a table that lists all the default settings.

Save and restore setups

Save setup:

Press **SAVE** > Select **SAVE** > Set memory location (**0 to 4**) > Press **ENTER**

Restore user setup:

Press **SETUP** > Select **USER** > Set memory location (**0 to 4**) > Press **ENTER**

Restore PRESET defaults:

Press **SETUP** > Select **PRESET**

Restore *RST defaults:

Press **SETUP** > Select ***RST**

Remote programming

*SAV <NRf>	‘ Save present setup in memory.
*RCL <NRf>	‘ Recall saved user setup from memory. ‘ <NRf> = 0, 1, 2, 3, or 4
SYSTem:PRESet	‘ Restore PRESET default setup.
*RST	‘ Restore *RST default setup.

Select power-on setup

Power-on to PRESET defaults:

Press **SETUP** > Select **POWER ON** > Select **PRESET**

Power-on to *RST defaults:

Press **SETUP** > Select **POWER ON** > Select ***RST**

Power-on to user setup:

Press **SETUP** > Select **POWER ON** > Select **USER SETUP NUMBER** >
Set memory location (**0 to 4**) > Press **ENTER**

Remote programming

SYSTEM:POSetup <name> ' Select power-on setup.
' <name> = RST, PRESet, SAV0, SAV1, SAV2, SAV3, or
' SAV4.

SCPI programming

SCPI programming information is integrated with front panel operation throughout this manual. SCPI commands are listed in tables and additional information that pertains exclusively to remote operation is provided after each table.

NOTE Except for Section 14 in the Reference Manual, most SCPI tables in this manual are abridged to some degree. That is, they may NOT include optional command words and most query commands. Optional command words and query commands are summarized as follows.

Optional command words

In order to be in conformance with the IEEE-488.2 and SCPI standards, the Model 622x accepts optional command words. Any command word that is enclosed in brackets ([]) is optional and need not be included in the program message.

Query commands

Most command words have a query form. A query command is identified by the question mark (?) that follows the command word. A query command requests (queries) the programmed status of that command. When a query command is sent and the Model 622x is addressed to talk, the response message is sent to the computer.

Output Connections

Section 2 topics

Output connectors, page 2-2

Triax connector, page 2-2

Ground points, page 2-3

LO and GUARD banana jacks, page 2-3

INTERLOCK, page 2-4

Output configurations, page 2-5

Triax inner shield, page 2-6

Triax output low, page 2-7

Guards, page 2-8

Triax Cable Guard, page 2-8

Floating the current source, page 2-9

Connections to DUT, page 2-9

Supplied triax cable, page 2-9

Basic connections, page 2-10

Shields and guarding, page 2-10

Using a test fixture, page 2-12

NOTE The information in this section is an abbreviated version of the information in Section 2 of the Reference Manual. Refer to Section 2 of the Reference Manual for complete details and additional information that is not provided in this manual.

Output connectors

Triax connector

Current source output is accessed at the 3-lug female triax connector on the rear panel. Use a 3-slot male triax cable to make connections to this connector. A triax cable terminated with alligator clips (Model 237-ALG-2) is a supplied item for the Model 622x (see “[Supplied triax cable](#)” on page 2-9). The triax connector is shown in [Figure 2-1](#).

Figure 2-1
Triax connector and grounds points

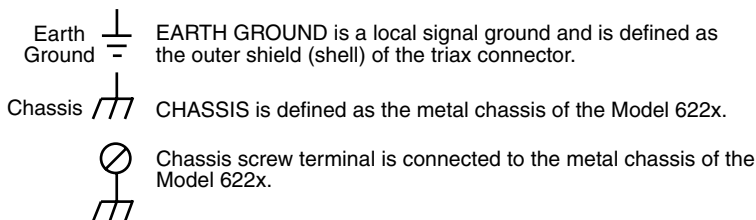
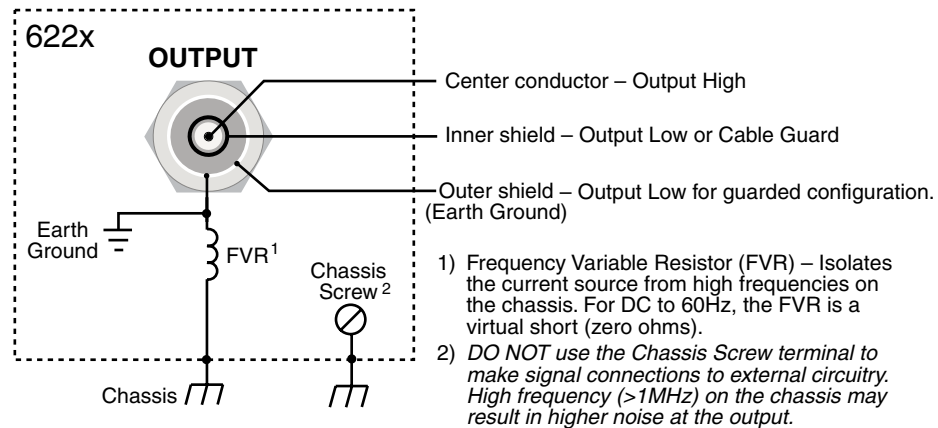

Triax connector terminals

The triax connector terminals are summarized as follows. For details on these terminals, see “[Output configurations](#)” on page 2-5.

Center conductor – The center conductor of the triax connector is always connected to Output High of the current source.

Inner shield – The inner shield of the triax connector can be connected to Output Low or Cable Guard. See “[Triax inner shield](#)” on page 2-6 for details on the inner

shield connection setting. See [“Triax Cable Guard”](#) on page 2-8 for details on using the Cable Guard.

Outer shield – The outer shield of the triax connector is always connected to Earth Ground of the Model 622x (see [“Ground points”](#) for details).

Frequency variable resistor (FVR)

The outer shield (Earth Ground) of the triax connector is isolated from the chassis of the Model 622x by a Frequency Variable Resistor (FVR). The FVR (shown in [Figure 2-1](#)) is used to isolate the current source circuitry from high frequencies that may be present on the chassis of the Model 622x. As frequencies on the chassis increase, the resistance of the FVR increases to dampen its effects.

Ground points

The various ground points used by the Model 622x are shown and explained in [Figure 2-1](#). The ground point for signal connections to external circuitry is **Earth Ground**. Earth Ground is the outer shield of the triax connector and is isolated from the **Chassis** by the FVR.

Keep in mind that the **Chassis** should never be used as a ground point for signal connections. High frequencies present on the chassis of the Model 622x may result in higher noise on the output.

The **Chassis** should only be used as a safety shield. Use the **Chassis Screw** for connections to the chassis of the Model 622x.

LO and GUARD banana jacks

The LO and GUARD banana jacks are located on the rear panel and are shown in [Figure 2-2](#).

Figure 2-2
LO and GUARD banana jacks

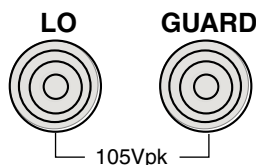

LO banana jack

The LO banana jack is electrically identical to the Output Low accessed at the triax connector. However, when using the **CABLE GUARD** and **FLOATING** triax settings, Output Low *is not* available at the triax connector. The LO banana jack must be used as Output Low (see [“Output configurations”](#) on page 2-5 for details on the triax connector settings).

GUARD banana jack

The **GUARD** available at the banana jack is different from **CABLE GUARD** that can be accessed at the triax cable. See “[Guards](#)” on page 2-8 for more information.

INTERLOCK

The Model 622x is equipped with an INTERLOCK that is to be connected to an interlock switch (see [Figure 2-3](#)). When the interlock switch is open, the OUTPUT of the Model 622x is disabled and cannot be turned on. If the OUTPUT is already on, opening the interlock switch will turn the OUTPUT off. When the interlock switch is closed, the OUTPUT is enabled and can be turned on.

[Figure 2-3](#) shows the connector for INTERLOCK. It is a quick-disconnect screw-terminal block. Pull the terminal block off the rear panel to connect the interlock switch.

The interlock switch is mounted on a test fixture such that the switch will open (disable the OUTPUT) when the test fixture lid is opened. The switch will close (enable the OUTPUT) when the test fixture lid is closed. See “[Using a test fixture](#)” page 2-12 for details on using INTERLOCK with a test fixture.

Figure 2-3
INTERLOCK

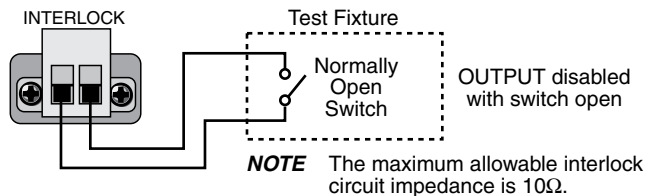

WARNING An open INTERLOCK only disables the output from the Model 622x. If an external source is being used in the test circuit, its voltage will be present in the test circuit. A hazardous voltage from an external source could be connected directly to the OUTPUT connector of the Model 622x.

As a general rule of safety, always turn off all external sources before making or breaking connections to the test circuit.

Output configurations

There are four configurations that can be used for current source output:

- Triax inner shield is connected to **Output Low**, which is connected to **Earth Ground** (see [Figure 2-4A](#)).
- Triax inner shield is connected to **Cable Guard** and **Output Low** is connected to **Earth Ground** (see [Figure 2-5A](#)).
- Triax inner shield is connected to **Output Low**, which is disconnected from Earth Ground (**Floating**) (see [Figure 2-4B](#)). This is the default setting.
- Triax inner shield is connected to **Cable Guard**. **Output Low** is accessed at the LO banana jack and is disconnected from Earth Ground (**Floating**) (see [Figure 2-5B](#)).

Using the Model 622x with the triax inner shield connected to Output Low makes it compatible with the Keithley Model 220 current source.

WARNING To prevent electric shock and/or damage to the Model 622x, **DO NOT** exceed the maximum (Max) voltage levels indicated in [Figure 2-4](#) and [Figure 2-5](#).

CAUTION To prevent damage to internal fuses of the Model 622x, current from output low to earth ground must be limited to 1A. Use a fuse or other current limiting device in the external test circuit. One internal fuse is located between the Triax Output Low and banana jack LO. The other internal fuse is located between Triax Output Low and earth ground.

Figure 2-4

Output configurations – triax inner shield connected to Output Low

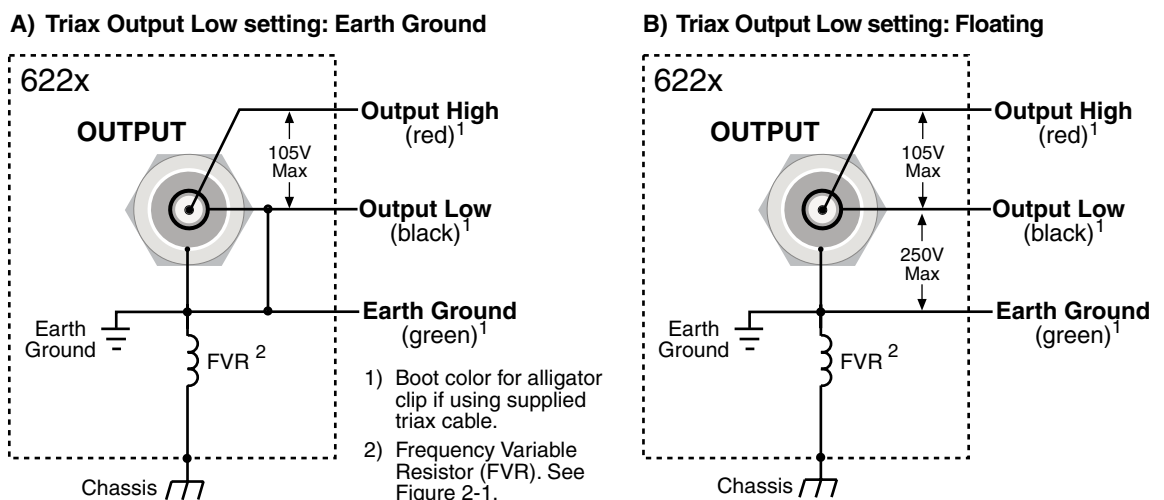

Return to [Section 2 topics](#)

Figure 2-5

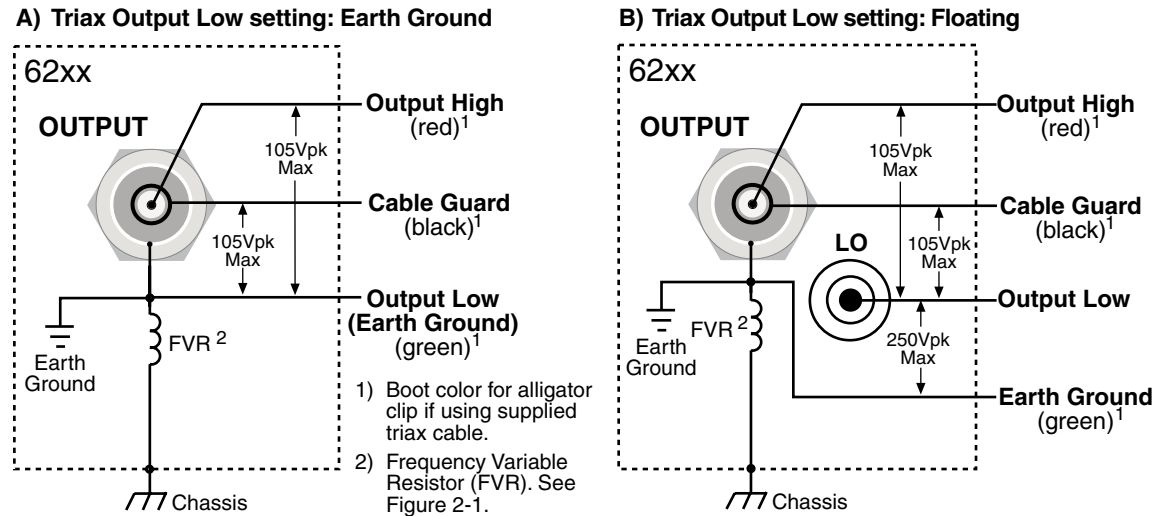
Output configurations – triax inner shield connected to Cable Guard

Triax inner shield

The inner shield of the triax connector can be connected to Output Low (to be compatible with the Keithley 220 Current Source) or to Cable Guard. Output Low is the default connection.

The current source OUTPUT must be OFF in order to change the inner shield setting. Perform the following steps to check or change the inner shield connection:

1. If the current source output is on, press the **OUTPUT** key to turn it **OFF** (“OFF” message is displayed).
2. On the Model 622x, press the **TRIAX** key to display the **CONFIGURE TRIAX** menu.
3. Using the cursor controls, place the blinking cursor on **INNER SHIELD** and press the **ENTER** key to display the **TRIAX INNER SHIELD** options.
4. Place the cursor on **OUTPUT LOW (220 STYLE)** or **GUARD** and press the **ENTER** key.
5. Press the **EXIT** key to return to the normal display state.

Remote programming (triax inner shield)

Changing the inner shield connection can only be done with the current source OUTPUT OFF. Otherwise, error +403 Not allowed with output on will occur.

Commands for triax inner shield connection:

```
OUTPut:ISHield?           ' Query connection for triax inner shield.
OUTPut:ISHield <name>    ' Connect inner shield to Cable Guard or Output Low.
                          ' <name> = GUARd or OLOW
```

Example – Turns off the current source OUTPUT and connects the inner shield of the OUTPUT connector to Cable Guard:

```
OUTPut OFF
OUTPut:ISHield GUARd
```

Triax output low

Output Low can be connected to Earth Ground (which is the outer shell of the triax connector) or it can float. By default, Output Low floats.

Perform the following steps to check or change the Output Low connection:

1. On the Model 622x, press the **TRIAx** key to display the **CONFIGURE TRIAX** menu.
2. Using the cursor controls, place the blinking cursor on **OUTPUT LOW** and press the **ENTER** key to display the **TRIAx OUTPUT LOW** options.
3. Place the cursor on **FLOATING** or **EARTH GROUND** and press the **ENTER** key.
4. Press the **EXIT** key to return to the normal display state.

Remote programming (triax output low)

Commands for output low connection:

```
OUTPut:LTEarth?         ' Query connection for output low.
OUTPut:LTEarth <b>     ' Enable or disable triax output low connection to Earth
                       ' Ground.
                       ' <b> = ON (Earth Ground)
                       '      = OFF (Floating)
```

Example – Disconnects (floats) triax output low from Earth Ground:

```
OUTPut:LTEarth OFF
```

Guards

The Model 622x provides two guards: triax Cable Guard and banana jack Guard.

Cable Guard – This guard provides a voltage that is at essentially the same potential as Output High of the Model 622x. Guarding may greatly reduce leakage current and capacitance in the test circuit. Effective guarding requires that the triax Cable Guard configuration be used for the triax cable and a guard plate be used for the DUT.

Banana Jack Guard – This guard is similar to cable guard in that it provides a voltage that is essentially the same potential as Output High (1mV accuracy, typical). This guard should not be used to guard a triax cable. Rather, banana jack Guard is designed for use with a voltmeter to make measurements on a high-impedance DUT.

NOTE Details on using the banana jack Guard is provided in Section 2 of the Reference Manual.

Triax Cable Guard

A triax cable has insulation resistance and capacitance between its conductors. A typical triax cable could typically have $1\text{T}\Omega/\text{ft.}$ of insulation resistance and $100\text{pF}/\text{ft.}$ of cable capacitance. Significant insulation resistance and capacitance can also be present in the test fixture for the DUT.

Capacitance – Any capacitance that exists between the output and the DUT slows down the response (current rise time) at the DUT. When the Model 622x output is turned on (or a step change occurs), there is an initial current surge through the capacitance seen across the load. Current will stop flowing through the capacitor after it fully charges. A current is considered to be “settled” when it is within 1% of its final value. It takes approximately five RC time constants (5τ) for the capacitor to charge and allow the settled current to flow through the DUT.

Leakage current – After the capacitance charges, it is effectively removed from the test circuit (assuming the source level remains constant). Insulation resistance in parallel with the DUT is left, effectively making a current divider. Leakage current (not delivered to the DUT) can be significant if the insulation resistance is not significantly greater than the resistance of the DUT. For example, if the insulation resistance is only 10 times the resistance of the DUT, then 10% sourcing error will occur.

NOTE The principles of guarding are explained in Section 2 of the Reference Manual (see “Guards”).

When to use Cable Guard

When to use Cable Guard is a judgement call that must be made by the user. In general, Cable Guard is used to reduce leakage current for high-impedance DUT, and reduce capacitance in the triax cable and at the DUT to improve output response (rise time). Lower capacitance results in faster output response.

While Cable Guard will greatly reduce capacitance in the triax cable and at the DUT, there are other possible sources of high capacitance that can greatly degrade the overall effectiveness of guarding.

The DUT (or test circuit) may inherently have high capacitance, and/or the voltmeter used in the test system may have high capacitance. These capacitances, which cannot be guarded out, may negate the need for Cable Guard (especially for low-impedance DUT). The Keithley Model 2182/2182A Nanovoltmeter has relatively high input capacitance (~300pF, and ~500pF in special mode only).

Floating the current source

Using an external source in the test system may require that the Model 622x current source float off Earth Ground. Depending on the test circuit configuration, the external source could possibly be shorted through Earth Ground if the Model 622x is not floating off Earth Ground. Details on “Floating the current source” are provided in Section 2 of the Reference Manual.

Connections to DUT

WARNING To prevent electric shock, all power must be removed from the test system before making or breaking connections. Turn off all equipment and sources, and disconnect their power cords.

Supplied triax cable

The Model 237-ALG-2 triax cable is supplied with the Model 622x. This 6.6ft (2m) cable mates to the OUTPUT triax connector and is terminated with alligator clips that are covered with color-coded boots. Terminal identification for the cable depends on the triax connector configuration (see [Figure 2-4](#) and [Figure 2-5](#)).

WARNING The Model 237-ALG-2 triax cable can allow exposed voltages when used in certain applications.

This triax cable is intended for use only by qualified personnel who recognize shock hazards and are familiar with the safety precautions required to avoid possible injury. If this product is to be used by an operator, a qualified person must ensure the operator is protected from electric shock and contact with hazardous live circuits.

Basic connections

Basic connections can be used for low voltage (not greater than 30Vrms, 42Vpeak) testing where guarding and/or noise shielding are not required. Basic connections to a DUT are shown in [Figure 2-6](#). Use the connections shown in [Figure 2-6A](#) if the inner shield of the triax connector is connected to Output Low. Use the connections shown in [Figure 2-6B](#) if the inner shield is connected to Cable Guard.

Figure 2-6

Basic connections to DUT

A) Inner shield connected to Output Low

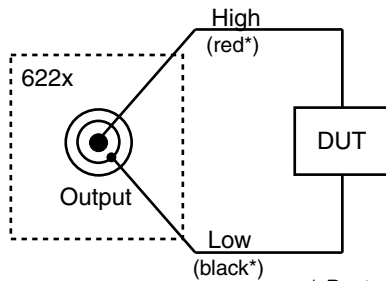

B) Inner shield connected to Cable Guard

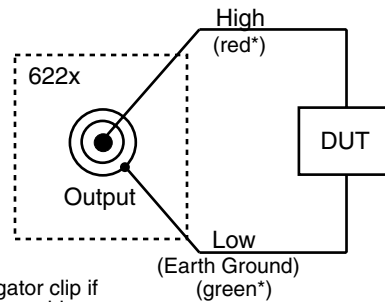

* Boot color for alligator clip if using supplied triax cable.

Shields and guarding

Noise shield connections

[Figure 2-7](#) shows typical noise shielding for the two triax connector configurations. A noise shield is used to prevent unwanted signals from being induced into the test circuit. A test current below 1 μ A may benefit from effective shielding. Typically, the metal noise shield surrounds the DUT and is connected to Output Low.

Figure 2-7

Noise shield

A) Inner shield connected to Output Low

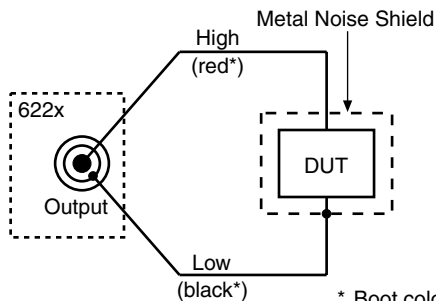

B) Inner shield connected to Cable Guard, Output Low connected to earth ground

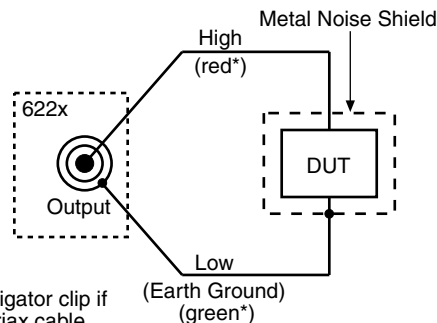

* Boot color for alligator clip if using supplied triax cable.

Safety shield connections

A safety shield must be used whenever hazardous voltages (>30Vrms, 42Vpeak) will be present. The metal safety shield must completely surround DUT test circuitry and must be connected to a known Safety Earth Ground and Chassis (see [Figure 2-8](#)). Use #18AWG wire or larger for connections.

Figure 2-8
Safety shield

A) Inner shield connected to Output Low

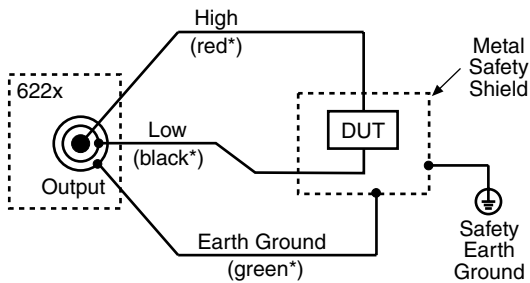

B) Inner shield connected to Cable Guard, Output Low connected to earth ground

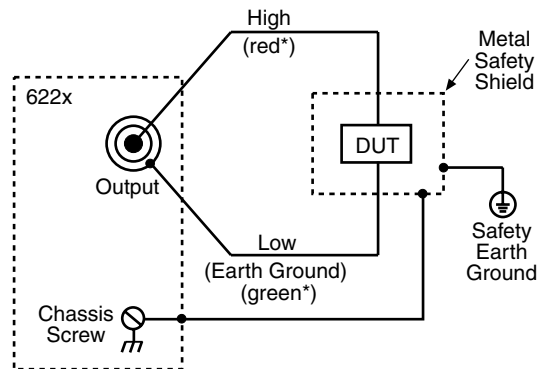

* Boot color for alligator clip if using supplied triax cable.

Cable Guard connections

Triax Cable Guard is used to provide guarding for the triax cable and can be extended all the way to the DUT at a metal guard plate. Connections for Cable Guard are shown in [Figure 2-9](#).

Figure 2-9
Cable Guard connections – triax inner shield connected to Cable Guard

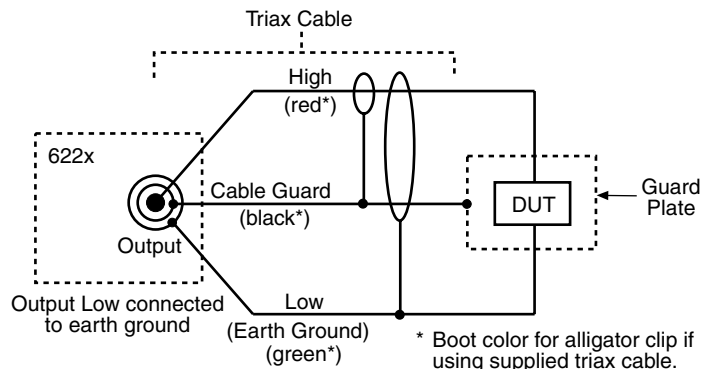

* Boot color for alligator clip if using supplied triax cable.

A safety shield must be used whenever hazardous voltages ($>30\text{Vrms}$, 42Vpeak) will be present in the test circuit. [Figure 2-10](#) shows how to make guarded connections with the use of a safety shield.

Using shielding and guarding together

[Figure 2-10](#) shows connections for a test system that uses a noise shield, a safety shield, and guarding.

Figure 2-10
Connections for noise shield, safety shield, and guarding

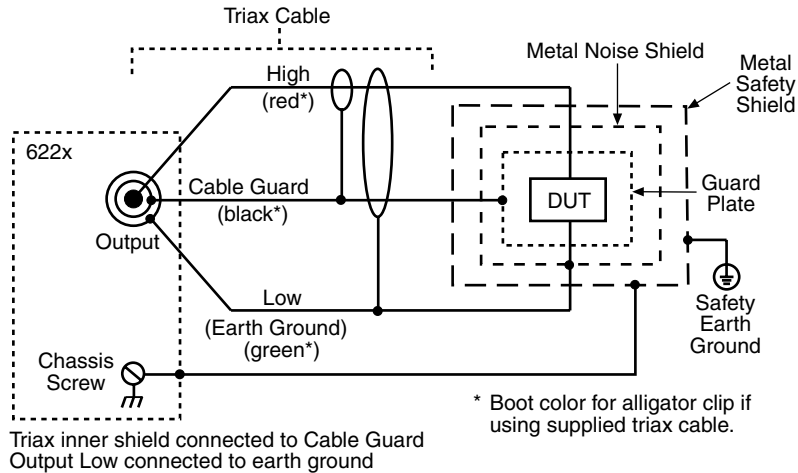

Using a test fixture

In order to facilitate safe operation and optimum performance, a safety test fixture with a built-in interlock switch must be used. The interlock switch of the test fixture is to be connected to the “[INTERLOCK](#)” of the Model 622x (see page 2-4).

NOTE Guidelines to build a safe, high performance test fixture are provided in Section 2 of the Reference Manual (see “Using a test fixture”).

DC Current Source Operation

Section 3 topics

Current source output capabilities, page 3-2

Source ranges, page 3-2

Compliance, page 3-3

Output power (source or sink), page 3-3

Output response, page 3-5

Setting source and compliance, page 3-8

Source and compliance editing, page 3-8

Sourcing current, page 3-12

Remote programming – source output commands, page 3-15

NOTE The information in this section is an abbreviated version of the information in Section 3 of the Reference Manual. Refer to Section 3 of the Reference Manual for complete details and additional information that is not provided in this manual.

NOTE Supplied example software allows you to control a Model 622x from any PC using simple mouse clicks through a virtual front panel. For details, see “Using the example software” in Section 10 of the Reference Manual.

Current source output capabilities

- Nine ranges to source current from 100fA to 105mA.
- Compliance can be set from 0.1V to 105V in 10mV steps.
- Maximum output power is 11W.
- Four quadrant (source and sink) source operation

Source ranges

Each source range has 5% overrange capability. Each source range and its maximum output is listed in [Table 3-1](#). A source range can be selected manually, or autorange can be used.

Manual ranging – A fixed source range can be selected manually using the **RANGE** Δ and ∇ keys. When selecting a fixed range, select the lowest (best) possible range that will accommodate the output current. For example, if sourcing 12mA, select the 20mA range.

Autorange – For front panel operation, the **AUTO** key is a single action control. When pressed, the best range is selected for the displayed source value. For remote operation, autorange is always active when it is enabled, and the Model 622x will automatically select the best (lowest) source range for the source value.

NOTE More information on “**Autorange**” is provided on [page 3-11](#). The commands for ranging are listed in [Table 3-2](#).

Table 3-1
Source ranges and maximum outputs

Source Range	Max Output	Source Range	Max Output	Source Range	Max Output
2nA	± 2.1 nA	2 μ A	± 2.1 μ A	2mA	± 2.1 mA
20nA	± 21 nA	20 μ A	± 21 μ A	20mA	± 21 mA
200nA	± 210 nA	200 μ A	± 210 μ A	100mA	± 105 mA

Compliance

The compliance setting limits the output voltage of the Model 622x. The voltage compliance limit can be set from 0.1V to 105V in 10mV steps. The output will not exceed the programmed compliance level.

Make sure to set compliance to a voltage level that is greater than the voltage requirements for the load. For example, if sourcing 10mA to a 1k Ω load, the voltage compliance setting must be >10V (10mA x 1k Ω = 10V). If it is not, the Model 622x goes into compliance and the magnitude of the current output will be less than the programmed setting. For example, if compliance is set to 9V and current output is set to 10mA, only 9mA will be sourced to a 1k Ω load (9V/1k Ω = 9mA).

The OUTPUT indicator light blinks when the current source is in compliance. Either there is a fault condition in the test circuit, or the source and/or compliance levels are not properly set.

Compliance overshoot

Depending on range and load impedance, step changes in current could cause the output voltage to briefly overshoot its normal expected level by as much as 2V. During normal “out of compliance” operation, this voltage “glitch” will settle to the expected output voltage within the settling time specification for the selected range (see “[Output response](#)” on page 3-5).

If the compliance voltage is set too close to the expected output voltage, the overshoot could place the Model 622x in compliance. Due to the compliance circuitry, it could take several microseconds for the overshoot to settle and return the current source to the “out of compliance” state. This slower response to overshoot could damage a voltage sensitive DUT (Device Under Test).

One way to avoid compliance overshoot is to set a compliance that is at least 2V above the expected static output voltage. For example, if the normal operating voltage across the load is 10V, set the compliance to at least 12V.

Additional details on compliance overshoot and prevention are provided in Appendix E of the Reference Manual.

Output power (source or sink)

The maximum power output of the Model 622x is 11W. The bipolar current source provides four quadrant source or sink operation. When connected to a passive DUT, the Model 622x operates as a source. When connected to an active load (e.g., external source, capacitor), the Model 622x can operate as a source or sink.

When operating as a source, current is delivered to a test circuit. The polarity of the current and the voltage seen at the output are the same (both positive or both negative).

When operating as a sink, the Model 622x is dissipating power rather than sourcing it. The polarity of the current and voltage seen at the output is opposite (one positive, one negative). An external source or an energy storage device, such as a capacitor, can force operation into the sink region.

Figure 3-1 shows examples of the Model 622x connected to an external source where it can operate as a source or sink. For both examples, the Model 622x is programmed to output +10mA. When connected to the 1k Ω resistor and 10V source as shown in Figure 3-1A, the Model 622x operates as a 200mW source supplying power to the external test circuit. When the external voltage is decreased to -30V as shown in Figure 3-1B, the Model 622x instead operates as a sink. The Model 622x dissipates 200mW of power (10mA x -20V = -200mW).

Figure 3-1
Source and sink examples

A) Source operation

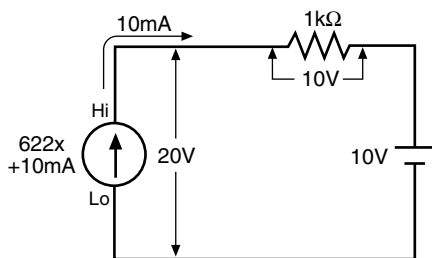

B) Sink operation

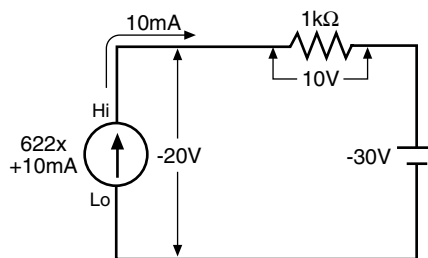

Operating boundaries

Figure 3-2 shows the four quadrants of operation for the Model 622x. When operating in the first (I) or third (III) quadrant, the Model 622x is operating as a source. Figure 3-1A shows an example of quadrant I operation (current and voltage both positive).

When operating in the second (II) or fourth (IV) quadrant, the Model 622x is operating as a sink. Figure 3-1B shows an example of quadrant IV operation (current positive and voltage negative).

Figure 3-2
Output boundaries (source and sink)

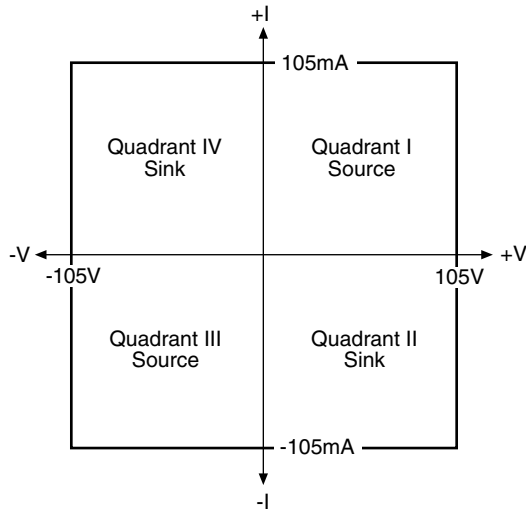

Output response

Output response is the time it takes for an output change to settle to within 1% of its final value. For the Model 6220, output response (settling time) can be as fast as 100 μ s (typical). For The Model 6221, output response can be as fast as 2 μ s (typical) for the higher source ranges. If desired, the output response of the Model 6221 can be set to match the output response of the Model 6220 (both typically 100 μ s).

For the Models 6220 and 6221, an analog filter can be enabled to slow down the output response. For a high-impedance load, the analog filter reduces overshoot, excessive noise, and instability (oscillation).

Analog filter

The Model 622x has an analog filter that, when enabled, will slow down the output response (settling time) of the current source.

When the analog filter is enabled, a capacitor (typically 33pF) is placed across the output. Depending on the load impedance, the analog filter may or may not significantly increase the settling time of the current source.

For example, assume the Model 6221 is on the 2mA range and FAST response is selected. For this configuration, the Settling Time is specified at 2 μ s (typical). Also assume the load impedance is 1k Ω . With the analog filter enabled, the additional settling time (five time constants) is calculated as follows:

$$\begin{aligned}\text{Additional settling time} &= 5RC \\ &= 5 \times 1\text{k}\Omega \times 33\text{pF} \\ &= 0.165\mu\text{s}\end{aligned}$$

Enabling the analog filter adds 0.165 μ s settling time, which is not a significant increase in comparison to 2 μ s.

Now assume the load is 1M Ω . The additional settling time with the analog filter enabled is 165 μ s (5 x 1M Ω x 33pF). The analog filter greatly increased the settling time from 2 μ s to approximately 167 μ s.

NOTE The above example is only intended to show how load impedance affects settling time when using the analog filter. Actual settling times will also depend on other impedances present in the test circuit, such as capacitance and leakage resistance in cabling and in the test fixture.

For load impedances <10k Ω , the analog filter has little effect on the output response. At the 10k Ω load impedance point, the filter capacitor across the load creates a filter response of less than 1MHz, which is the maximum output bandwidth of the Model 6221 for the higher current ranges.

For load impedances greater than 1M Ω , the reduced response of the filtered output can significantly reduce overshoot, noise, and instability (oscillation).

With the analog filter disabled, the output capacitance of the Model 622x is <10pF.

If not sure about using the analog filter, experimentation may be the best way to determine which analog filter state (enabled or disabled) provides the best results.

NOTE An external user-supplied filter can be effective at reducing high frequency noise generated by the Model 622x current source. For details, see “External user-supplied filter” in Appendix E of the Reference Manual.

Response speed setting (6221 only)

The filter response speed of the Model 6221 can be set for FAST or SLOW. For the SLOW setting, the output response of the Model 6221 is the same as the output response of the Model 6220.

The FAST setting allows a faster output response. The FAST response setting changes the maximum output response bandwidth of the Model 6221 to 1MHz. It also reduces stability. The output will remain stable into a 10 μ Hz (typical) load. For a more complex load, the faster speed may make the test system more susceptible to oscillation.

Note that output stability into an inductive load is only dependent on the response mode setting and is not affected by the analog filter (on or off).

Again, experimentation may be the best way to determine which response setting (FAST or SLOW) provides the best results.

Settling time specifications

The output "Settling Time" specifications are listed in [Appendix A](#) and assume that the analog filter is disabled. For the Model 6221, settling times are provided for the FAST and SLOW response speed settings. Note that the SLOW setting of the Model 6221 has the same response as the Model 6220. Enabling the analog filter may or may not significantly increase settling times. For details, see "[Analog filter](#)" on page 3-5.

NOTE All settling times are typical into a resistive load to 1% of final value.

The listed settling times in [Appendix A](#) are specified for a resistive load. The maximum load resistance for the specified settling times is calculated as follows:

$$\text{Max Load Resistance} = 2V / I_{\text{FULL SCALE OF RANGE}}$$

For example, on the 20mA range, the max load resistance is calculated as follows:

$$\text{Max Load Resistance} = 2V / 20\text{mA} = 100\Omega$$

The settling times for other load conditions can be calculated as explained in Section 3 of the Reference Manual (see "Settling time specifications").

Setting source and compliance

Source and compliance editing from the front panel cannot be performed from the front panel if the Model 622x is in remote. To return to the local state, press the **LOCAL** key.

For **remote programming**, commands to select source range, and set source and compliance values are shown in [Table 3-2](#). Programming examples are also provided in the procedure for “[Sourcing current](#)” on page 3-12.

Source and compliance editing

[Figure 3-3](#) explains how to set source and compliance values for the Model 6220. [Figure 3-4](#) shows the source and compliance editing controls for the Model 6221. The procedure to set source and compliance values for the Model 6221 follow [Figure 3-4](#). “[Source/compliance editing notes](#)” for both procedures are provided on page 3-9.

Figure 3-3
Source and compliance editing – Model 6220

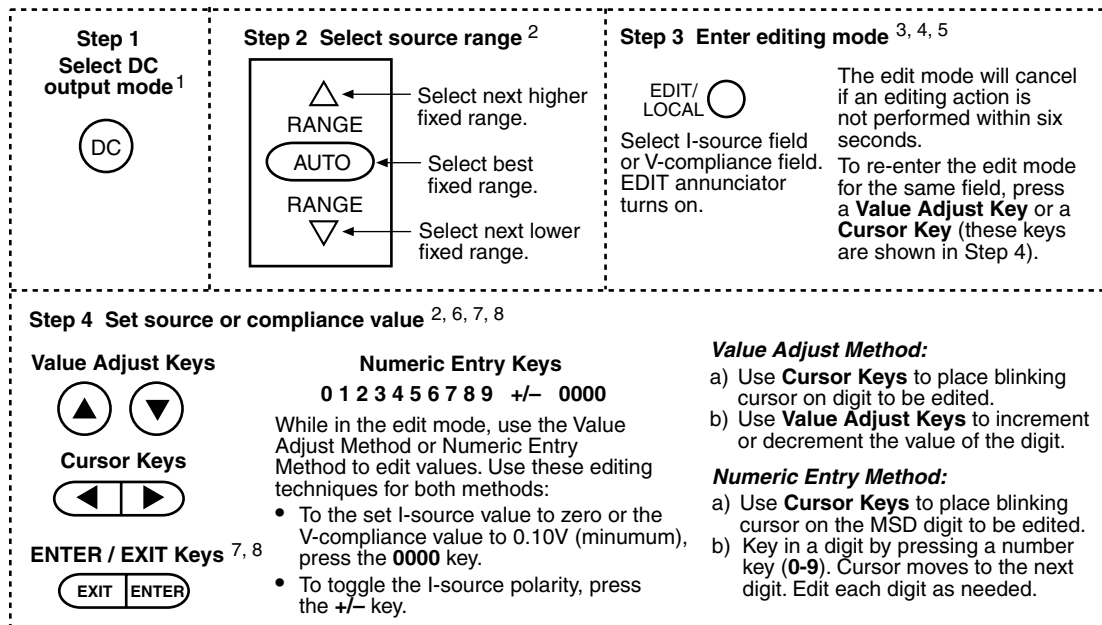

Source/compliance editing notes

The following notes apply to source editing for both the Models 6220 (Figure 3-3) and 6221 (Figure 3-4):

1. The displayed source and/or compliance value can only be edited if the **DC** source mode is selected.
2. Select a fixed range that will accommodate the source value to be set. Note that after a source value is set (Step 4 in Figure 3-3), pressing **AUTO** range will select the best fixed range (if it is not already selected). Details on "Autorange" are provided on page 3-11.
3. The Model 622x must be in the edit mode in order to edit source and compliance values.
4. The first press of the **EDIT** key selects the editing mode for the I-source field (EDIT annunciator turns on). Each subsequent press toggles between the source field and the compliance field. The flashing digit indicates which reading (source or compliance) is presently selected for editing.
5. The unit will exit the editing mode if an editing action is not performed within six seconds. To re-enter the edit mode, perform one of the following.
 - For the Model 6220, press a **Value Adjust Key** or a **Cursor Key** to re-enter the edit mode for the last selected field.
 - For the Model 6221, press a **Cursor Key** or the **Rotary Knob** to re-enter the edit mode for the last selected field.
 - For both models, press the **EDIT** key to re-enter the edit mode for the I-source field.
6. You cannot set a digit to a value that exceeds the maximum allowable setting. For the I-source field, the largest allowable value is limited by the selected range (e.g., $\pm 2.1000\text{mA}$ for the 2mA source range). For the I-compliance field, the largest allowable value is 105.00V.
7. When editing the source value, the output is updated immediately, allowing you to adjust the source value while the output is on. To exit the edit mode, allow it to time out, or press **ENTER** or **EXIT**.
8. When editing the compliance value, compliance is not updated until the edit mode is allowed to time out, or when **ENTER** or **EXIT** is pressed.

Figure 3-4
Source and compliance editing – Model 6221

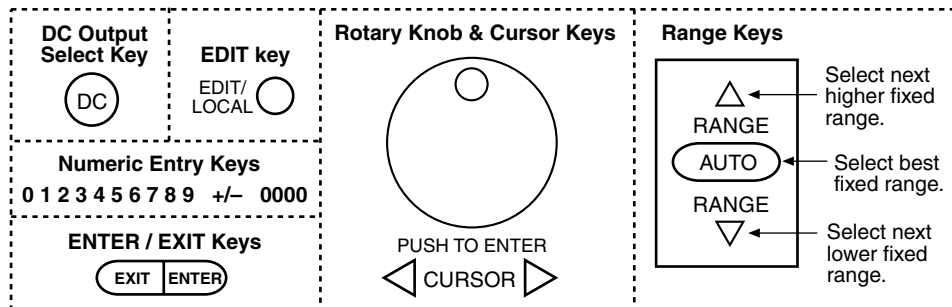

Perform the following steps to set source and compliance values for the Model 6221. The notes in the steps refer to the ["Source/compliance editing notes"](#) on page 3-9.

- Step 1 Select DC output mode**¹ – Press the **DC Output Select Key** to select the DC output mode.
- Step 2 Select source range**² – Use the **Range Keys** to select a source range.
- Step 3 Enter source editing mode**^{3, 4, 5} – Use the **EDIT Key** to select the I-source field or V-compliance field (EDIT annunciator turns on). The editing mode will cancel if an editing action is not performed within six seconds. To re-enter the edit mode for the same field, press a **Cursor Key**, or push and release the **Rotary Knob**.
- Step 4 Set source or compliance value**^{2, 6, 7, 8} – Use the Value Adjust Method or Numeric Entry Method to edit values. Use these editing techniques for both methods:
- To set the I-source value to zero or set the V-compliance value to 0.10V (minimum), press the **0000** key.
 - To toggle the I-source polarity, press the **+/-** key.

Value Adjust Method:

- Use the **Cursor Keys** to place the blinking cursor on the digit to be edited.
- Turn the **Rotary Knob** clockwise to increment the value, or counter-clockwise to decrement.

Numeric Entry Method:

- Use the **Cursor Keys** to place the blinking cursor on the digit to be edited.
- Key in a digit by pressing a number key (**0-9**). The cursor moves to the next digit. Edit each digit as needed.

Autorange

Front panel operation

The **AUTO** range key is a single action control to select the best fixed range for the displayed source value. After setting a source value, pressing **AUTO** will ensure that the best fixed range is selected.

For example, assume the source is set to +1mA on the 20mA range (+01.000 mA displayed). When the **AUTO** key is pressed, the range will change to the 2mA range (which is the best range).

Autorange is only asserted (enabled) for the instant that the **AUTO** key is pressed. Therefore, the AUTO annunciator does not turn on. If already on the best range, pressing **AUTO** will result in no action.

Remote operation

For remote operation, autorange remains active when it is enabled. When the source value is changed, the range will (if needed) automatically change to the best range for that value. With auto range enabled, the AUTO annunciator turns on to indicate that autorange is active.

For example, assume autorange is enabled, and the source is presently set for 1mA on the 1mA range. When the source value is changed to 5mA, the range will automatically uprange to the 10mA range.

Active autorange will disable if a command to select a fixed range is sent. The commands to control autorange and select a fixed range are listed in [Table 3-2](#).

NOTE Active autorange is only intended for remote operation. When the Model 622x is taken out of remote (e.g., LOCAL key pressed), the AUTO annunciator stays on and automatic down-ranging remains active. Active autorange will disable (AUTO annunciator turns off) when a RANGE Δ or ∇ key is pressed.

Source preset

The **PRES** key can be used to set the source to a preset value and range. When the **PRES** key is pressed, the source will select the preset range and set the preset value. The preset value is set as follows:

1. Press the **PRES** key. The message “PRES” is displayed while the preset value is being used.
2. Using the source editing keys as explained in [Figure 3-3](#) and [Figure 3-4](#), set the preset value to the desired level.

When finished using the preset value, press **PRES** again to disable the feature. The “PRES” message will cancel, and the unit will return to the original source value. Note that the compliance value cannot be preset, and source preset values cannot be saved as part of a user setup.

Sourcing current

To source current, (1) connect the test circuit (DUT) to the output, (2) set the source range output value and compliance, (3) enable the output filter (if desired), and finally, (4) turn the output on.

1. **Connect test circuit (DUT) to Model 622x output.**

WARNING Before making or breaking connections, the Model 622x must be turned off and the power cord must be disconnected from the AC outlet. Also, power must be removed from all external test circuits and instrumentation.

Connection information is provided in [Section 2](#). Keep in mind that there are two basic output triax connector configurations that can be selected:

- **Inner shield connected to Output Low.** Cable Guard is not available.
 - **Inner shield connected to Cable Guard** with Output Low connected to the outer shield (Earth Ground) of the triax connector.
2. **Set the source and compliance values.**
 - [Figure 3-3](#) explains how to set the source and compliance values for the Model 6220.
 - [Figure 3-4](#) explains how to set the source and compliance values for the Model 6221.

While in the edit mode, **AUTO** range can be used, but range changes will not occur during the editing process.

After setting the I-source value for a fixed range, enabling **AUTO** range will select the optimum (lowest) range for the source value.

Remote programming – Autorange can be used when setting the I-source value. With autorange enabled, the Model 622x will automatically select the optimum (lowest) range to accommodate the source value.

The commands to select the source range, and set the output and compliance values are provided in [Table 3-2](#). The following examples demonstrate proper syntax.

Example – Select the 20mA source range, set the source to output 12mA, and set compliance to 10V:

```
CURRent:RANGe 12e-3      ' Selects the 20mA range.*
CURRent 12e-3           ' Sets the DC output to 12mA.
CURRent:COMPLIance 10   ' Sets voltage compliance to 10V.
```

* To select a fixed source range, specify a parameter value that is the same as the current output value to be sourced. For the parameter value “12e-3”, the Model 622x selects the lowest range (20mA) that will accommodate a 12mA output.

3. If desired, change the output response.

For the Models 6220 and 6221, an analog output filter can be enabled to slow down the output response. For the Model 6221, the output response can be set to FAST or SLOW. See [“Output response”, page 3-5](#) for details on setting the output response.

Analog filter – Use the **FILT** key to toggle the state (on or off) of the low-pass filter. When this key is first pressed, the message “FILTER ON” will be briefly displayed and the “FILT” annunciator turns on. To disable the filter, again press the **FILT** key (“FILT” annunciator turns off).

Response speed setting (6221) – The response speed can only be changed while the output is off. Response speed is set as follows:

- a. Press the **CONFIG** key and then the **OUTPUT** key to display the output response menu.

NOTE If the output was on when attempting to access the output response menu, the output will turn off. Repeat step a above to access the output response menu.

- b. Using the controls for [“Menu navigation”](#) on page 1-14, select the **FAST** or **SLOW (6220 STYLE)** response speed.

For **remote programming**, the commands to set output response are shown in [Table 3-2](#). The following example demonstrates proper syntax.

Example – Enables the analog filter and, for the Model 6221, sets the output response to fast:

```
CURRent:FILTer ON      ' Enables the analog filter.  
OUTPut:RESPonse FAST ' Sets the output response of the 6221 to FAST.
```

4. Turn on the output.

NOTE In order to turn on the output, an interlock switch must be connected to the INTERLOCK connector on the rear panel of the Model 622x. Closing the interlock switch will enable the OUTPUT allowing it to be turned on. For details, see [“INTERLOCK”](#) on page 2-4.

The **OUTPUT** key toggles the output state (on or off). When the output is turned on, the OUTPUT indicator light turns on.

For **remote programming**, the command to control the output is shown in [Table 3-2](#). The following example demonstrates proper syntax.

Example – Turns the output on:

```
OUTPut ON      ' Turns output on.
```

The OUTPUT indicator will blink if the current source goes into compliance. This indicates that the set current is not being delivered to the load. See [“Compliance”](#) on page 3-3 for details.

Remote programming – source output commands

Table 3-2 lists the commands to configure and control the DC output. A programming example to output DC current is also provided.

Table 3-2

DC output commands

Command	Description	Default
CLEAr	Turns output off and sets output level to zero.	
CURRent:RANGe <n>	Sets current source range (amps). ^{1, 2} <n> = -105e-3 to 105e-3	100e-3
CURRent:RANGe:AUTO 	Enables or disables source autorange. = ON or OFF	OFF
CURRent <n>	Sets DC current source output level (amps). <n> = -105e-3 to 105e-3	0.0
CURRent:COMPLIance <NRf>	Sets voltage compliance (volts). <NRf> = 0.1 to 105	10.0
CURRent:FILTer 	Enables or disables the output analog filter. = ON or OFF	OFF
OUTPut:RESPOse <name>	Select fast or slow output response speed for 6221. <name> = FAST or SLOW ^{3, 4}	FAST
OUTPut 	Turn output on or off. = ON or OFF	OFF
SourceMeter	Sets output to zero, then turns the output off ⁴	

1. To select a fixed source range, specify the current output value that is going to be sourced. The Model 622x will go to the lowest range that can source that value. For example, If you are going to source 25mA, let <n> = 25e-3. The 100mA range will be selected.
2. Selecting a fixed source range disables autorange.
3. The output must be off in order change the output response. Sending this command while the output is on will generate error -220 Execution Error.
4. OUTP OFF turns the output off, but does change the set output level. SOUR:CLE sets the output level to zero and then turns the output off.

Programming example

The following programming example shows a typical command sequence to configure and control the DC output:

CLEar	' Turns the output off.
CURRent:RANGe:AUTO ON	' Enables autorange.
CURRent 12e-3	' Sets output level to +12mA.
CURRent:COMPLIance 10	' Sets voltage compliance to 10V.
OUTPut ON	' Turns the output on.
OUTPut OFF	' Turns the output off.

Applications

Some applications for the Model 622x are summarized below. See Appendix E of the Reference Manual for details on these applications.

- **Calibration source** – Explains how to use Model 622x as a current calibration source. The custom sweep function allows a user-defined list of current source values to be stored in memory. During the calibration process, each current source level is output in the order that it appears in the list.
- **Resistivity measurements** – Certain semiconductor materials such as silicon have high resistivities. The Model 622x can be used to source stable and accurate current, and the Keithley 6514 Electrometer can be used to provide an accurate voltage measurement. Resistivity is then calculated.
- **Diode characterization** – With the Model 622x and Keithley 6514 Electrometer, it is possible to plot I-V (current-voltage) characteristics of a diode over several decades. The Model 6514, with its high input resistance, will allow the voltage measurement to be accurately made.
- **Transistor characterization** – The Model 622x can be used with a Keithley 24xx SourceMeter to characterize a device's electrical DC parameters. The Model 622x Current Source is configured to sweep a number of base currents for the test. The Model 24xx SourceMeter is configured to sweep voltage and measure current.
- **External user-supplied filter** – Based on load impedance and response time requirements, a user-supplied filter can be effective at reducing high frequency noise generated by the Model 622x current source.
- **Compliance overshoot prevention** – Depending on range and load impedance, step changes in current could cause the output voltage to briefly overshoot its set compliance level by as much as 2V and take several microseconds to settle. A few microseconds of overshoot could be enough to damage voltage sensitive devices.

4 Sweeps

Section 4 topics

Sweep overview, page 4-2

Linear staircase sweep, page 4-2

Logarithmic staircase sweep, page 4-2

Custom sweep, page 4-2

Sweep characteristics, page 4-4

Custom sweep editing, page 4-4

Using auto-copy with custom sweeps, page 4-4

Source ranging, page 4-4

Sweep delay, page 4-5

Front panel sweep operation, page 4-5

Using the sweep configuration menu, page 4-5

Performing a staircase sweep, page 4-6

Running a staircase sweep, page 4-9

Remote sweep operation, page 4-8

Running a staircase sweep, page 4-9

Running a custom sweep, page 4-10

SCPI commands — sweeps, page 4-11

NOTE The information in this section is an abbreviated version of the information in Section 4 of the Reference Manual. Refer to Section 4 of the Reference Manual for complete details and additional information that is not provided in this manual.

Sweep overview

As shown in [Figure 4-1](#), the Model 622x Current Source can generate three types of DC current sweeps.

NOTE User setups cannot be saved or recalled while a sweep is armed or running. Attempting to do so will generate error +413 Not allowed with mode arm.

Linear staircase sweep

With this sweep type, the current increases or decreases in specific steps, beginning with a start current and ending with a stop current. [Figure 4-1A](#) shows an increasing linear staircase sweep from a 1mA start current to a 5mA stop current in 1mA steps. The bias current is the fixed current setting just prior to the start of the sweep. The current output will remain at the last point in the sweep after completion.

Logarithmic staircase sweep

In this case, the current increases or decreases logarithmically, beginning with a start current and ending with a stop current. [Figure 4-1B](#) shows an increasing log staircase sweep from a 0.1mA start current to a 100mA stop current with logarithmic steps. Again, the bias current is the fixed current setting just prior to the start of the sweep. The current output will remain at the last point in the sweep after completion.

Custom sweep

The custom sweep allows you to program arbitrary sweep steps anywhere within the output current range of the Model 622x. [Figure 4-1C](#) shows a typical custom sweep with arbitrary steps. As with the other two sweep types, the bias current is the fixed current setting just prior to the start of the sweep. The current output will remain at the last point in the sweep after completion.

NOTE A custom sweep cannot be saved as a user setup. Attempting to do so will generate error +528 Cannot save CUSTOM sweep setup.

Figure 4-1
Comparison of sweep types

A. Linear Staircase Sweep

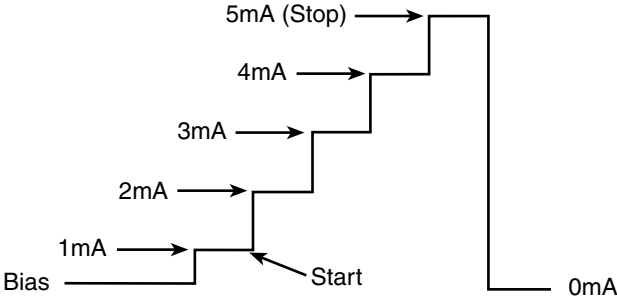

B. Logarithmic Staircase Sweep

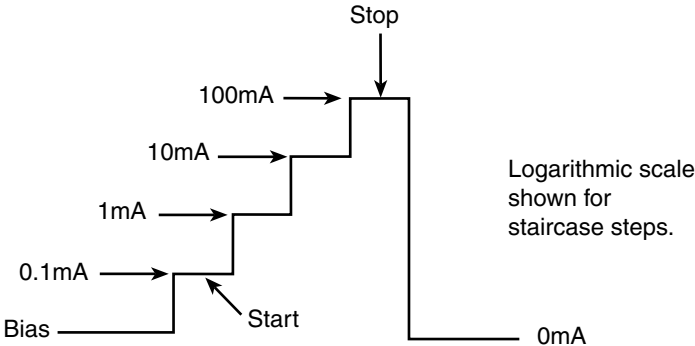

C. Custom Sweep

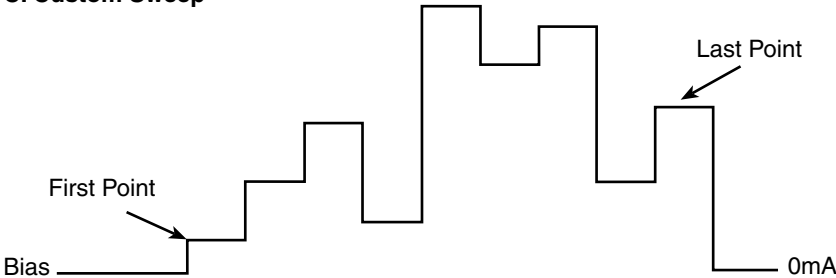

Sweep characteristics

NOTE Jitter – Step-to-step sweep timing may jitter as much as 1 ms. This jitter can be eliminated by disabling the front panel. For details, see “[Step-to-step timing jitter](#)” on [page 1-12](#).

Custom sweep editing

A typical custom sweep editing display is shown below:

```
P12345: +1.234567 mA  
Del:123456.789s Cmpl:100.00 V
```

The leftmost value on the top line is the point number, and the next value is the actual current setting. The formatting also shows the current range. The bottom line values are delay in seconds and compliance. Before entering this display, use the #-POINTS menu to select the number of sweep points. The editing for the custom sweep point adjust menu will not accept values above the number of points selected.

Using auto-copy with custom sweeps

An “auto-copy” feature is included to help reduce keystrokes when editing custom sweeps. If auto-copy is enabled, whenever a point is entered (by pressing the ENTER key), the compliance and delay values will automatically be copied to all higher-numbered points in the list.

Source ranging

The source ranging setting determines how the Model 622x selects the current range based on the sweep steps as follows:

- **BEST** — With this option, the unit will select a single fixed source range that will accommodate all of the source levels in the sweep.
- **AUTO** — With this option, the Model 622x will select the most sensitive source range for each source level in the sweep. Note that the output current goes to zero during the range change.
- **FIXED** — With this option, the source remains on the range it is on when the sweep is started. For sweep points that exceed the source range capability, the source will output the maximum level for that range.

Sweep delay

The sweep delay parameter determines how long the Model 622x will remain on each sweep step once the output current is set to the step value. For linear and logarithmic staircase sweeps, the sweep delay period is the same for every step in the sweep. For custom sweeps, the sweep delay for each step can be independently programmed.

The programmable range for the sweep delay is from 0.001s to 999999.999s.

Front panel sweep operation

Using the sweep configuration menu

To configure sweeps, press CONFIG then SWP, then make your selections from [Table 4-1](#) below. See the detailed procedures for each sweep type below.

Table 4-1
Sweep configuration menu

Menu selection	Description
TYPE STAIR LOG CUSTOM	Select sweep type: Set START, STOP, STEP, DELAY. Set START, STOP, NO OF POINTS, DELAY. Set #-POINTS, ADJUST POINTS, AUTO COPY*.
SWEEP-COUNT FINITE INFINITE	Choose sweep count: Enter desired # of sweeps. Continuously repeating sweeps.
SOURCE-RANGING BEST AUTO FIXED	Select source ranging: Use best range based on maximum sweep step. Auto range based on individual sweep step. Always stay on fixed source range.
COMPLIANCE-ABORT NO YES	Select compliance abort mode: Do not abort sweep if compliance reached. Abort sweep if compliance reached.

* Select AUTO COPY ON to automatically copy delay and compliance values to all sweep points.

Performing a staircase sweep

1. **Configure source functions:**
 - a. If desired, set the bias current (output current prior to the start of the sweep) by pressing the DC key and then setting the current to the desired value.
 - b. Select the compliance display field, then set the voltage compliance as appropriate for expected sweep parameters.
2. **Configure the sweep as follows:**
 - a. Press CONFIG then SWP to enter the sweep configuration menu.
 - b. Select TYPE, then press ENTER.
 - c. Select STAIR or LOG, then press ENTER to choose a linear staircase sweep.
 - d. For STAIR sweeps, enter the desired START, STOP, STEP, and DELAY values. For LOG sweeps, enter the desired START, STOP, NO OF POINTS, and DELAY values.
 - e. From the CONFIGURE SWEEPS menu, select SWEEP-COUNT, press ENTER, then choose FINITE or INFINITE as desired.
 - f. Again from the CONFIGURE SWEEPS menu, choose SOURCE-RANGING, press ENTER, then select BEST, AUTO, or FIXED as appropriate.
 - g. From the CONFIGURE SWEEPS menu, select COMPLIANCE-ABORT, press ENTER, then choose to abort (YES) or not to abort (NO) the sweep if compliance is reached while the sweep is in progress.
 - h. Press EXIT to return to normal display.
3. **Run sweep:**
 - a. Press the SWP key to arm the sweep. The output will turn on.
 - b. Press TRIG to start the sweep.
 - c. Press EXIT to abort the sweep before it is finished.
 - d. Turn the output off by pressing the ON/OFF OUTPUT key when the sweep is finished.

Performing a custom sweep

1. Configure the bias current (output current prior to the start of the sweep) by pressing the DC key and then setting the current to the desired value.
2. **Configure the sweep as follows:**
 - a. Press CONFIG then SWP to enter the sweep configuration menu.
 - b. Select TYPE, then press ENTER.
 - c. Select CUSTOM, then press ENTER to choose a custom sweep.
 - d. Select #-POINTS, press ENTER, then enter the number of sweep points (64,000 maximum).
 - e. Choose AUTO-COPY, press ENTER, then enable (YES) or disable (NO) auto copy. With auto copy enabled, compliance and delay values are automatically copied to all sweep point locations.
 - f. Select ADJUST-POINTS, then set the current value, compliance, and delay for the first sweep point.
 - g. Set the current value, compliance (if not using auto-copy), and delay for each remaining sweep point.
 - h. From the CONFIGURE SWEEPS menu, select SWEEP-COUNT, press ENTER, then choose FINITE or INFINITE as desired.
 - i. Again from the CONFIGURE SWEEPS menu, choose SOURCE-RANGING, press ENTER, then select BEST, AUTO, or FIXED as appropriate.
 - j. From the CONFIGURE SWEEPS menu, select COMPLIANCE-ABORT, press ENTER, then choose to abort (YES) or not to abort (NO) the sweep if compliance is reached while the sweep is in progress.
 - k. Press EXIT to return to normal display.
3. **Run sweep:**
 - a. Press the SWP key to arm the sweep. The output will turn on.
 - b. Press TRIG to start the sweep.
 - c. Press EXIT to abort the sweep before it is finished.
 - d. Turn the output off by pressing the ON/OFF OUTPUT key when the sweep is finished.

Remote sweep operation

Procedures for programming and running a sweep are shown on the following pages. Each of these procedures includes commands for a typical sweep example. [Table 4-2](#) summarizes parameters for each of these examples. See [“SCPI commands — sweeps,” page 4-11](#) for listings of sweep commands.

Table 4-2

Sweep example parameters

Sweep type	Parameters for sweep examples
Linear staircase sweep (page 4-9)	Start current: 1mA Stop current: 10mA Step current: 1mA Delay: 1s Source range: best fixed Compliance abort: off Sweep count: 1 Bias current: 100 μ A Compliance: 10V
Custom (list) sweep (page 4-10)	# points: 5 Points: 3mA, 1mA, 4mA, 5mA, 2mA Delay: 3s, 1s, 4s, 5s, 2s Compliance: 3V, 1V, 4V, 5V, 2V Source range: auto Compliance abort: off Sweep count: 1 Bias current: 50 μ A

Running a staircase sweep

1. Configure source functions.

Examples – The following commands restore defaults, set the bias current to 100 μ A, and the compliance to 10V:

```
*RST                                ' Restore 622x defaults.
SOUR:CURR 1e-4                      ' Set bias current to 100 $\mu$ A
SOUR:CURR:COMP 10                   ' Set compliance to 10V.
```

2. Configure the sweep.

Examples – The following commands configure a single linear staircase sweep from 1mA to 10mA with 1mA steps using a 1s delay, best fixed source range, and compliance abort disabled:

```
SOUR:SWE:SPAC LIN                   ' Select linear staircase sweep.
SOUR:CURR:STAR 1e-3                 ' Set start current to 1mA.
SOUR:CURR:STOP 1e-2                 ' Set stop current to 10mA.
SOUR:CURR:STEP 1e-3                 ' Set step current to 1mA.
SOUR:DEL 1                           ' Set delay to 1s.
SOUR:SWE:RANG BEST                  ' Select best fixed source range.
SOUR:SWE:COUN 1                     ' Set sweep count to 1.
SOUR:SWE:CAB OFF                    ' Disable compliance abort.
```

3. Arm and run the sweep:

```
SOUR:SWE:ARM                        ' Arm sweep, turn on output.
INIT                                 ' Trigger sweep.
```

4. When the sweep is done, turn the source output off with this command:

```
OUTP OFF
```

Running a custom sweep

1. Configure source functions.

Examples – The following commands restore defaults and set the bias current to 50 μ A:

```
*RST                                ' Restore 622x defaults.
SOUR:CURR 5e-5                       ' Set bias current to 50 $\mu$ A
```

2. Configure the sweep.

Examples – The following commands configure a single custom sweep with five points, different delay and compliance settings for each point, auto source range, and compliance abort disabled:

```
SOUR:SWE:SPAC LIST                    ' Select custom sweep.
SOUR:SWE:RANG AUTO                     ' Select auto source range.
SOUR:LIST:CURR 3e-3,1e-3,4e-3,        ' Sweep points: 3mA, 1mA, 4mA,
5e-3,2e-3                               ' 5mA, 2mA.
SOUR:LIST:DEL 3,1,4,5,2                ' Delay points: 3s, 1s, 4s, 5s, 2s.
SOUR:LIST:COMP 3,1,4,5,2               ' Compliance = 3V, 1V, 4V, 5V, 2V.
SOUR:SWE:COUN 1                         ' Set sweep count to 1.
SOUR:SWE:CAB OFF                        ' Disable compliance abort.
```

3. Arm and run the sweep:

```
SOUR:SWE:ARM                          ' Arm sweep, turn on output.
INIT                                    ' Trigger sweep.
```

4. When the sweep is done, turn the source output off with this command:

```
OUTP OFF
```

SCPI commands — sweeps

Commands for linear and logarithmic staircase sweeps are listed in [Table 4-3](#), while commands for custom (list) sweeps are listed in [Table 4-4](#).

Table 4-3

Staircase sweep commands (linear and logarithmic)

Command	Description	Default
SOURCE [1] : CURRENT : START <n>	Sets start current. <n> = -0.105 to 0.105 (A)	0
SOURCE [1] : CURRENT : STOP <n>	Sets stop current. <n> = -0.105 to 0.105 (A)	0.1
SOURCE [1] : CURRENT : STEP <n>	Sets step current. <n> = 1e-13 to 0.105 (A)	1e-2
SOURCE [1] : CURRENT : CENTER <n>	Sets center current. <n> = -0.105 to 0.105 (A)	0
SOURCE [1] : CURRENT : SPAN <n>	Sets span current. <n> = 2e-13 to 0.210 (A)	0.1
SOURCE [1] : DELAY <n>	Sets source delay. <n> = 0.001 to 999999.999 (s)	1
SOURCE [1] : SWEEP : ARM	Prepare for running the sweep.	
SOURCE [1] : SWEEP : ABORT	Abort sweep immediately.	
SOURCE [1] : SWEEP : SPACING <name>	Selects sweep type. <name>=LINEar, LOGarithmic, or LIST	LINEar
SOURCE [1] : SWEEP : POINTS <n>	Sets sweep points. <n> = 1 to 65535	11
SOURCE [1] : SWEEP : RANGING <name>	Selects sweep source ranging. <name>=AUTO, BEST, or FIXEd	BEST
SOURCE [1] : SWEEP : CABORT 	Sets compliance sweep abort state. = ON or OFF	OFF
SOURCE [1] : SWEEP : COUNT <NRf>	Sets sweep count. <NRf> = 1 to 9999 or INFinite	1

Table 4-4
Custom (list) sweep commands

Command	Description
SOURCE [1] :LIST:CURRENT <NRf> [, <NRf>, ...<NRf>]	Defines list of currents. <NRf> = -0.105 to 0.105 (A)
SOURCE [1] :LIST:CURRENT:APPEND <NRf> [, <NRf>, ...<NRf>]	Adds current points to existing list. <NRf> = -0.105 to 0.105 (A)
SOURCE [1] :LIST:DELAY <NRf> [, <NRf>, ...<NRf>]	Defines list of delay values. <NRf> = 0 to 999.9999 (s)
SOURCE [1] :LIST:DELAY:APPEND <NRf> [, <NRf>, ...<NRf>]	Adds to list of delay values. <NRf> = 0.001 to 999999.999 (s)
SOURCE [1] :LIST:COMPLIANCE <NRf> [, <NRf>, ...<NRf>]	Defines list of compliance values. <NRf> = 0.1 to 105 (V)
SOURCE [1] :LIST:COMPLIANCE:APPEND <NRf> [, <NRf>, ...<NRf>]	Adds to list of compliance values. <NRf> = 0.1 to 105 (V)
SOURCE [1] :LIST:CURRENT:POINTS?	Query # of current list points.
SOURCE [1] :LIST:DELAY:POINTS?	Query # of delay list points.
SOURCE [1] :LIST:COMPLIANCE:POINTS?	Query # of delay list points.

5

Delta, Pulse Delta, and Differential Conductance

Section 5 topics

Operation overview, page 5-2

Test systems

- Keithley instrumentation requirements, page 5-4
- System configurations, page 5-4
- System connections, page 5-5
- DUT test connections, page 5-8
- Configuring communications, page 5-9
- Triggering sequence, page 5-10

Readings

- Display readings, page 5-11
- Measurement units, page 5-11
- Read commands, page 5-13

Delta

- Model 622x measurement process, page 5-13
- Configuration settings, page 5-15
- Operation, page 5-16
- Setup and arm commands, page 5-19

Pulse Delta

- Model 6221 measurement process, page 5-21
- Pulse Delta outputs, page 5-22
- Configuration settings, page 5-26
- Operation, page 5-29
- Setup commands, page 5-32

Differential Conductance

- Model 622x measurement process, page 5-34
- Configuration settings, page 5-37
- Operation, page 5-38
- Setup and arm commands, page 5-41

NOTE The information in this section is an abbreviated version of the information in Section 5 of the Reference Manual. Refer to Section 5 of the Reference Manual for complete details and additional information that is not provided in this manual.

Operation overview

The Model 6220 or 6221 Current Source can be used with a Model 2182/2182A Nanovoltmeter to perform Delta and Differential Conductance. The Model 6221/2182A combination can also perform Pulse Delta. These operations use a delta current-reversal technique to cancel the effects of thermal EMFs.

The Model 622x provides a bipolar output current and the Model 2182/2182A performs A/D conversions (measurements) at source high and source low points. An averaging algorithm is then used to calculate the delta reading.

Delta – The Model 622x provides a square wave current output, and the Model 2182/2182A performs A/D conversions (measurements) at each high and low output level. A 3-point moving-average algorithm is used to calculate Delta readings.

As shown in [Figure 5-1A](#), the first three Model 2182/2182A A/D conversions (measurements) yield the first Delta reading. Each subsequent Model 2182/2182A A/D conversion then yields a single Delta reading. Every Delta reading uses the three previous A/Ds to calculate Delta.

Pulse Delta – The Model 6221 outputs pulses and uses 3-point repeating-average measurements to calculate Pulse Delta voltage. For each pulse, the Model 2182A performs an A/D conversion (measurement) at pulse low, pulse high, and pulse low. Each set of three A/D readings yield a single Pulse Delta reading. [Figure 5-1B](#) shows Pulse Delta measurements. If device heating is a concern, 2-point measurements can instead be used (2nd low pulse not measured due to corruption from heat).

Differential Conductance – The Model 622x outputs a differential current (dI) sweep and measures differential voltage (dV). This function uses a 3-point moving average algorithm to calculate dV. With dI known and dV calculated, the Model 622x can then calculate differential conductance (dG) or differential resistance (dR). [Figure 5-1C](#) shows Differential Conductance measurements.

NOTE Jitter – For Delta and Differential Conductance, step-to-step timing may jitter as much as 1ms. This jitter can be eliminated by disabling the front panel. For details, see “[Step-to-step timing jitter](#)” on [page 1-12](#).

Figure 5-1
Delta, Pulse Delta, and Differential Conductance measurements

A) Delta measurements

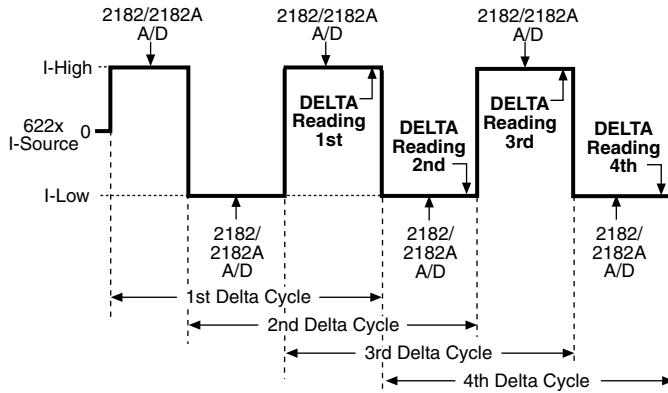

B) Pulse Delta measurements

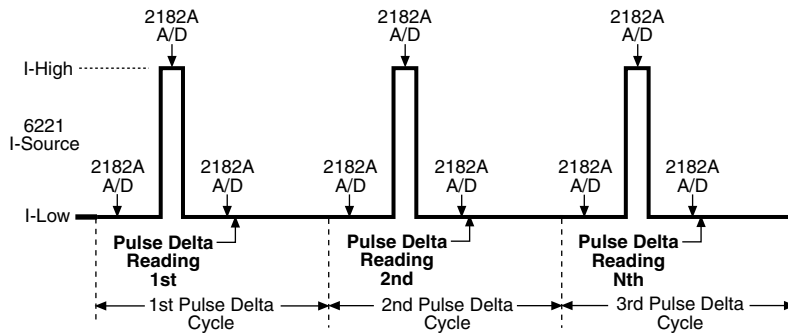

C) Differential Conductance measurements

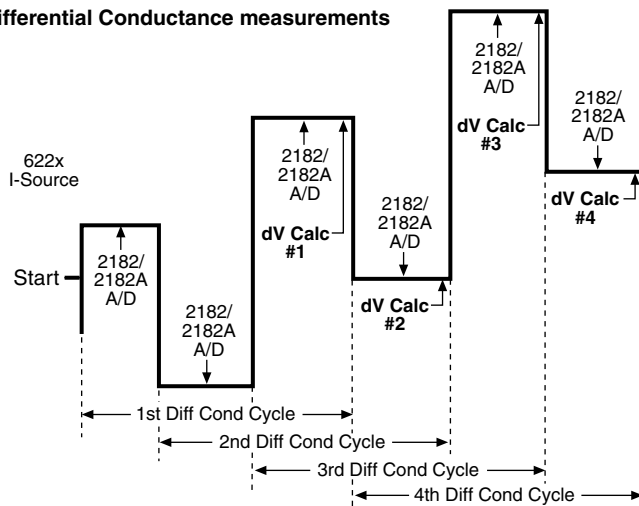

Test systems

NOTE Supplied example software allows you to control Model 622x delta tests from any PC using simple mouse-clicks through a virtual front panel. For details, see “Using the example software” in Section 10 of the Reference Manual.

Keithley instrumentation requirements

Keithley instrumentation requirements for Delta, Pulse Delta, and Differential Conductance are:

- **Models 6220 and 2182** – Delta and Differential Conductance
- **Models 6220 and 2182A** – Delta and Differential Conductance
- **Models 6221 and 2182** – Delta and Differential Conductance
- **Models 6221 and 2182A** – Delta, Pulse Delta, and Differential Conductance

NOTE The firmware version of the Model 2182 must be A10 or higher.
The firmware version of the Model 2182A must be C01 or higher.

System configurations

Stand-alone system

System configuration for stand-alone front panel operation is shown in [Figure 5-2A](#). The RS-232 interface for the Model 2182/2182A must be enabled (on) and the selected interface for the Model 622x must be the GPIB or the Ethernet (Model 6221).

PC control system

System configuration for PC control of the Model 622x is shown in [Figure 5-2B](#). The RS-232 interface for the Model 2182/2182A must be enabled (on) and the selected interface for the Model 622x must be the GPIB or the Ethernet (Model 6221).

Serial communications

In order to perform Delta, Pulse Delta, or Differential Conductance measurements, the Model 622x must communicate to the Model 2182/2182A over the serial (RS-232) interface. With serial communications properly configured and connected, the Model 622x will automatically send setup commands to the Model 2182/2182A when Delta, Pulse Delta, or Differential Conductance is armed. When the test is started, readings from the Model 2182/2182A are automatically sent to the Model 622x to be processed into Delta, Pulse Delta, or Differential Conductance readings that are then stored in the buffer.

Figure 5-2

System configurations for Delta, Pulse Delta, and Differential Conductance

A) Stand-alone system (front panel operation)

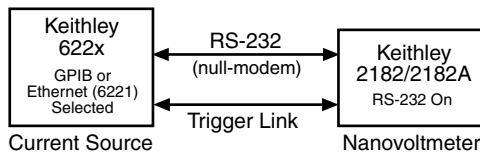

B) PC control of 6220/21

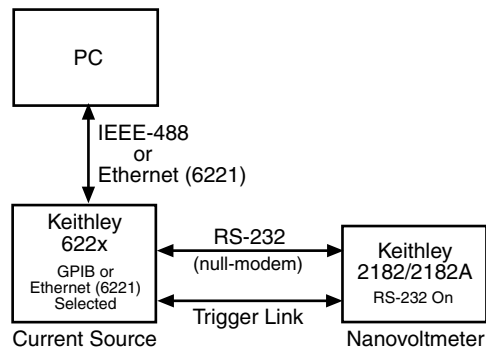

System connections

WARNING Before making or breaking system connections, the Models 622x and 2182/2182A, and the PC must be turned off and the line cords must be disconnected from AC line power.

System connections depend on the system configuration being used (see [Figure 5-2](#)). Connections for the two system configurations are explained as follows.

Connections – stand-alone system

System connections for this configuration are shown in [Figure 5-3](#).

RS-232 – The Model 622x communicates with the Model 2182/2182A via the RS-232 interface. Make sure to use a null-modem RS-232 cable for this connection.

Trigger Link – The Trigger Link synchronizes triggering between the Current Source and the Nanovoltmeter. Trigger Link connections assume that the Model 2182/2182A is using the factory default (hard-wired) configuration:

EXT TRIG (input) = line #2

VMC (output) = line #1

Delta, Pulse Delta, and Differential Conductance will not work if the Model 2182/2182A is not using the default Trigger Link configuration. See “Changing trigger link lines” in Section 5 (Disassembly) of the Model 2182/2182A Service Manual.

Figure 5-3

System connections – stand-alone operation

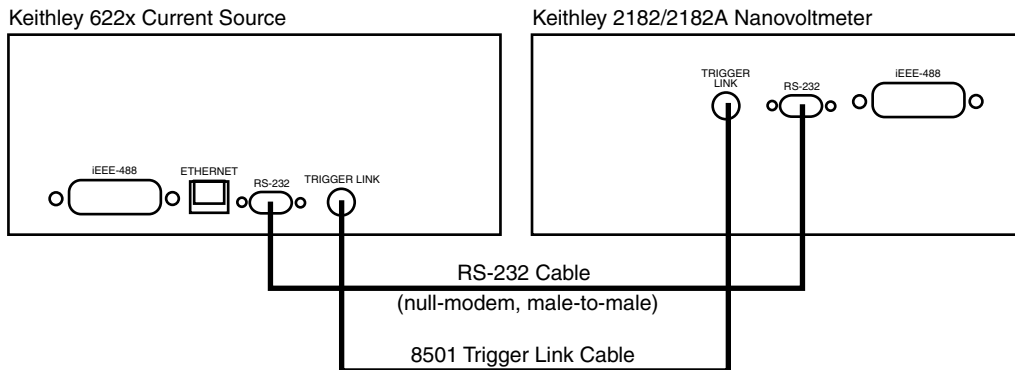

Connections – PC control system

System connections for this configuration are shown in [Figure 5-4](#).

RS-232 and Trigger Link – This system configuration uses the same RS-232 and Trigger Link connections that are used for stand-alone operation.

IEEE-488 or Ethernet (6221) – This system configuration uses a PC to communicate with the Model 622x. For the Model 6220, the IEEE-488 bus interface can be used. For the Model 6221, the IEEE-488 bus or the Ethernet can be used. For the Ethernet, make sure to use a cross-over Ethernet cable for direct connection to the PC.

Figure 5-4
System connections – PC control of Model 622x

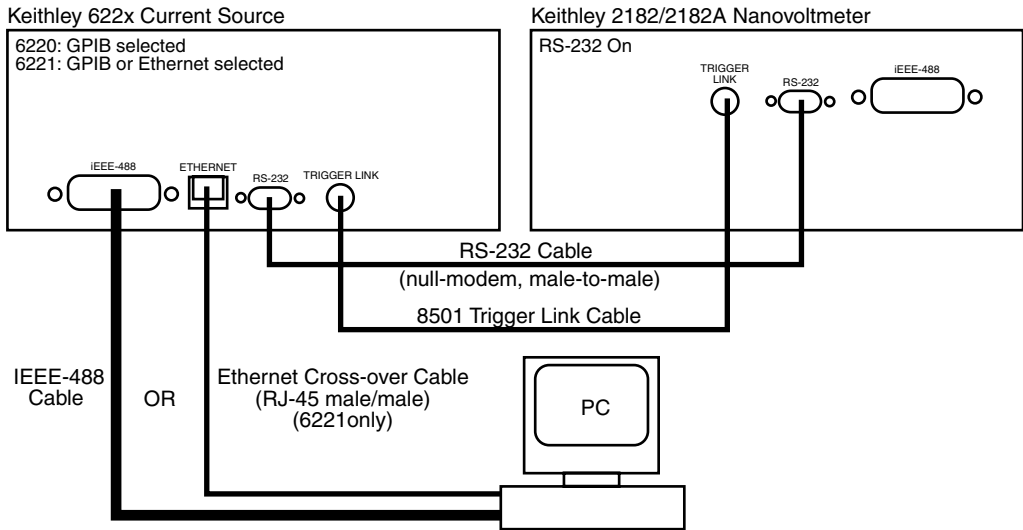

DUT test connections

WARNING Before making or breaking test connections, the Models 622x and 2182/2182A must be turned off and the line cords must be disconnected from AC line power.

DUT test connections are shown in [Figure 5-5](#). This connection scheme uses Cable Guard and an earth grounded test fixture that is equipped with an interlock switch. See [Section 2](#) of this manual for connection information. See Section 2 of the Reference Manual for details on the principles of Cable Guard and guidelines for test fixture requirements.

Figure 5-5
Guarded test connections

NOTE For this connection scheme, the inner shield of the Model 622x OUTPUT connector must be connected to the driven guard. See “[Triax inner shield](#)” on [page 2-6](#) for details on connecting the inner shield of the OUTPUT connector to Cable Guard.

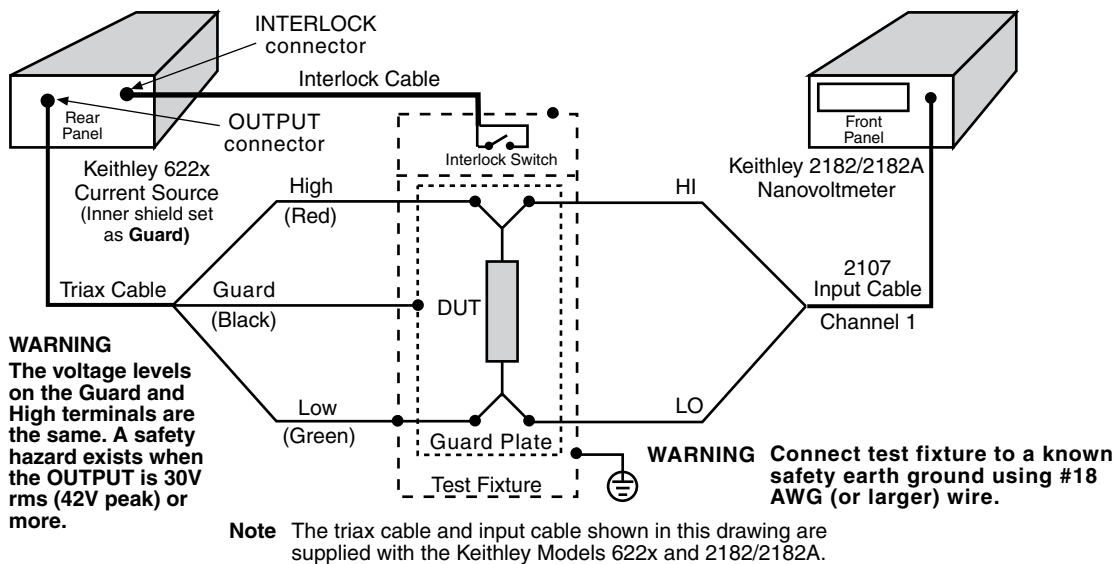

Configuring communications

For both front panel and remote operation, the RS-232 of the Model 2182/2182A must be enabled (on), and the selected communications interface for the Model 622x must be the GPIB or the Ethernet (Model 6221 only).

Model 2182/2182A communications

Configure the Model 2182/2182A for RS-232 communications as follows:

On the Model 2182/2182A, press the **SHIFT** key and then the **RS-232** key to access the RS-232 menu. From this menu, configure the RS-232 as follows:

1. Select **ON** for the RS-232 interface.
2. Select the **19.2K** baud rate.
3. Select the **NONE** setting for flow control.

Details on setting communications are provided in the User's Manual for the Model 2182/2182A (in Section 11, see "Interface selection and configuration procedures").

Model 622x communications

For Delta, Pulse Delta, and Differential Conductance, the Model 622x uses two interfaces for communications. It uses the RS-232 to communicate with the Model 2182/2182A, and it uses the GPIB or Ethernet (Model 6221 only) to communicate with the PC. For details on communications configuration for the Model 622x, see Section 10 of the Reference Manual.

Configure the Model 622x for communications as follows:

1. **RS-232** – On the Model 622x, press the **COMM** key and then select **RS-232** from the communications setup menu:
 - a. Set the **BAUD** rate to **19.2K**.
 - b. Set **FLOW CTRL** (flow control) to **NONE**.
 - c. Press the **ENTER** key.

The Model 622x will reboot if RS-232 was not the previously selected communications interface.

2. **GPIB or Ethernet** – The GPIB or the Ethernet (Model 6221 only) must be the selected interface to allow communications with the PC.

On the Model 622x, press the **COMM** key and then select **GPIB** or **ETHERNET** (6221 only) from the communications setup menu:

- GPIB – Set the IEEE-488 address (0 to 30).
- Ethernet (6221) – Set the IP, Gateway, Subnet, and DHCP.

After configuring the GPIB or Ethernet, press **ENTER**. The configured communications interface will be selected and the Model 622x will reboot.

Arming and Starting the Test

Arming – After a delta test is configured, the test is armed by pressing the **DELTA** key, **PULSE** key (Pulse Delta), or **COND** key (Differential Conductance). For remote programming, the following commands are used to arm the test:

SOUR:DELT:ARM	‘ Arm Delta
SOUR:PDEL:ARM	‘ Arm Pulse Delta
SOUR:DCON:ARM	‘ Arm Differential Conductance

During the arming process, the Model 622x establishes communications with the Model 2182/2182A and performs a series of operations. These arming operations are covered in Section 5 of the Reference Manual.

Starting the test – An armed test can be started by pressing the TRIG key, or sending the :INIT IMM command. Details on running a test are provided in the individual “Operation” procedures for Delta, Pulse Delta, and Differential Conductance later in this section.

Triggering sequence

The Trigger Link is used to synchronize source-measure triggering operations of the Models 622x and 2182/2182A. General trigger sequence for delta tests:

1. Model 622x outputs a current step or pulse.
2. After allowing the output to settle, the Model 622x outputs a trigger to the Model 2182/2182A to perform a measurement. The reading is sent back to the Model 622x (via serial port).
3. The Model 2182/2182A sends a trigger to the Model 622x to output the next current level or pulse.
4. Steps 2 and 3 are repeated until the test is finished.

While the test is running, the Model 622x will calculate Delta, Pulse Delta, or Differential Conductance from the readings it receives from the Model 2182/2182A. The readings will be displayed and stored in the buffer.

Details on the “Trigger sequence” for Delta, Pulse Delta, and Differential Conductance are provided in Section 5 of the Reference Manual.

Readings

Display readings

Display reading examples:

+1.23456 nV Delta	Delta voltage reading
+1.23456 Ω Delta	Delta ohms reading
+1.23456 S D Cond	Differential Conductance Siemens reading
+1.23456 mWp Pulse	Pulse Delta peak power (Watts) reading ^{1, 2, 3}
+1.23456 mW Pulse	Pulse Delta average power (Watts) reading ^{1, 2, 3}

1. Pulse Delta Power can be a peak power reading or an average power reading (see "Measurement units" in Section 5 of the Reference Manual).
2. For remote operation, the returned reading string for a Delta Pulse power reading indicates if it is a peak or average reading. Use the UNIT:POWer? command (see [Table 5-1](#)) to determine if the power reading is peak or average.
3. When recalling buffer statistics (such as Average or Standard Deviation) for Pulse Delta power readings, only the power units for the first stored reading is checked to determine if it is a Peak or Average power reading. The result of the buffer statistic will have the same units (W for Average or Wp for Peak) as the first stored reading.

NOTE The SMPL annunciator blinks on and off for every other reading that is acquired from the Model 2182/2182A.

Measurement units

Volts, ohms, power, or conductance

The readings from the Model 2182/2182A for Delta, Pulse Delta, or Differential Conductance are sent to the Model 622x as voltage readings. These readings can be displayed by the Model 622x as Volts (V), Ohms (Ω), power (Watts; W), or conductance (Siemens; S) readings.

The default units for the Model 622x is volts. With Ohms (Ω) units or Siemens (S) units selected, a reading is calculated as follows:

$$\Omega = V/I$$

$$S = I/V$$

Where: V is the Delta, Pulse Delta, or Differential Conductance voltage reading.
I is the current sourced by the Model 622x.

With Power units selected, power is calculated as follows:

Delta	Pulse Delta ¹	Differential Conductance ²
$W = I \times V$	$W_{PEAK} = I \times V$ $W_{AVG} = I \times V \times \text{Duty Cycle}$	$W = I_{AVG} \times V_{AVG}$

1. See Section 5 of the Reference Manual for details on “Peak power and Average power” for Pulse Delta.
2. See Section 5 of the Reference Manual for details on “Average Voltage and Power” for Differential Conductance.

Setting measurement units

From the front panel, units can be set as follows:

1. Press the **UNITS** key to display the READING UNITS menu.
2. Use the “[Menu navigation](#)” controls (see [page 1-14](#)) to select the desired measurement units (**VOLTS**, **OHMS**, **WATTS**, or **SIEMENS**).
3. Model 6221 only – After selecting **WATTS**, you will be prompted to select the POWER TYPE.
4. Select the desired power type (**AVERAGE** or **PEAK**).

Remote programming – Commands for setting units are listed in [Table 5-1](#).

Table 5-1

Measurement unit commands

Command	Description	Default
UNIT[:VOLT][:DC] <name>	Specify reading units*. <name> = V, OHMS, W, or SIEMens	V
UNIT:POWer[:TYPE] <name>	Set power units reading type for 6221 Pulse Delta. <name> = AVERAge or PEAK	PEAK
UNIT:POWer[:TYPE] ?	Query power units reading type	

* The <name> parameter for Siemens can be sent as S, SIEM, or SIEMENS.

Example – Selects power (W) measurement units for the Model 622x:

```
UNIT W
```

Read commands

The Model 622x does not perform measurements. However, raw readings are sent from the Model 2182/2182A to the Model 622x to calculate Delta, Pulse Delta, or Differential Conductance readings. Readings from the Model 2182/2182A are processed, stored, and displayed by the Model 622x.

The following read commands return pre-math readings and buffer readings. Details on all read commands are provided in Section 5 of the Reference Manual.

Pre-math readings

SENSE[1]:DATA[:LATEST]?

SENSE[1]:DATA:FRESH?

While Delta, Pulse Delta, or Differential Conductance is running, the SENS:DATA:LATEST? command can be sent to read the latest (last) pre-math reading processed by the Model 622x. The returned reading will be filtered if the averaging filter is enabled. If this read command is sent before a new reading is available, the last reading will again be returned.

The SENS:DATA:FRESH? command is the same as the SENS:DATA:LATEST? command except that once a reading is returned, it cannot be returned again. This read command guarantees that each reading gets returned only once. If a new (fresh) reading is not available when SENS:DATA:FRESH? is sent, error -230 Data corrupt or stale will occur.

Buffer readings

TRACe:DATA?

This is the read command to return all readings stored in the buffer. There are also commands to determine the type of readings stored in the buffer, specify a list of consecutive buffer readings to return, and to read the selected buffer statistic. See "Data flow and read commands" in Section 5 of the Reference Manual.

Delta

Model 622x measurement process

The Delta process is shown in [Figure 5-6](#). As shown, three Model 2182/2182A A/D conversions are performed to yield a single Delta reading. When Delta starts, three Model 2182/2182A A/Ds (A, B, and C) are performed and the Delta reading is calculated. After the first Delta cycle, the moving-average technique is then used. As shown, a Delta reading is yielded for every subsequent Model 2182/2182A A/D. The new A/D replaces the oldest A/D in the Delta calculation.

Figure 5-6
Delta measurement technique

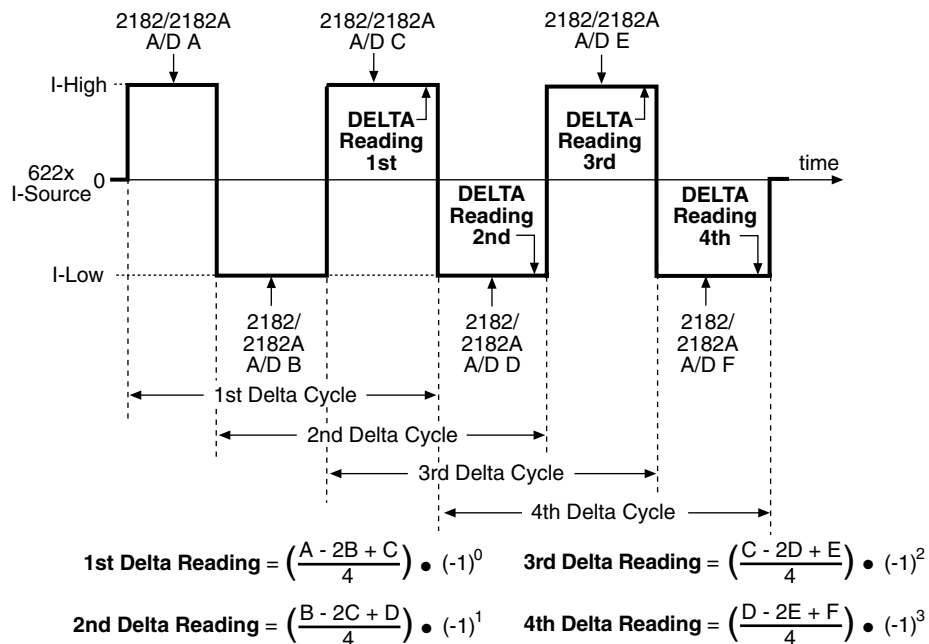

The following equation can be used to calculate any Delta reading:

$$\text{Delta} = \left(\frac{X - 2Y + Z}{4} \right) \cdot (-1)^n$$

Where: X, Y, and Z are the three A/D measurements for a Delta reading.

n = Delta Cycle Number – 1

Example – Calculate the 21st Delta reading:

X, Y, and Z are the three A/D measurements for the 21st Delta reading.

n = Delta Cycle Number – 1

$$= 21 - 1$$

$$= 20$$

Therefore;

$$\begin{aligned} \text{Delta} &= \left(\frac{X - 2Y + Z}{4} \right) \cdot (-1)^{20} \\ &= \frac{X - 2Y + Z}{4} \end{aligned}$$

The $(-1)^n$ term in the Delta calculation is used for polarity reversal of every other calculated Delta reading. This makes all calculated Delta readings in the test the same polarity.

Measurement units

The fundamental measurement for Delta is voltage (Volts; V). However, the voltage reading can be converted into a conductance (Siemens; S), resistance (Ohms; Ω), or power (Watts; W) reading. See [page 5-11](#) for details on selecting “[Measurement units](#)”.

Configuration settings

Delta settings from the front panel are described as follows. These parameters are set from the CONFIGURE DELTA menu that is accessed by pressing the **CONFIG** key and then the **DELTA** key.

The equivalent remote programming commands to configure Delta are summarized in [Table 5-2](#).

I-High and I-Low – These settings specify the high and low level for the square wave output. When setting the I-High level, the I-Low level is set to the same magnitude but negative polarity. For example, setting I-High to 1mA sets I-Low to -1mA. Setting the I-Low level has no effect on I-High.

I-High can be set from 0 to +105mA, and I-Low can be set from 0 to -105mA. The default settings for high and low are +1mA and -1mA.

Delay – The Delta delay occurs after a trigger from the Model 2182/2182A is received and is typically used to allow the current source to settle after changing polarity. Delay can be set from 0.001 to 9999.999s. The default delay is 2ms.

Count – Delta count specifies the number of Delta readings to perform. Delta count can be set to a finite number (1 to 65,536) or Infinity can be selected. With an infinite count selected, the Delta runs continuously. The default count setting is Infinity. The separate sweep count parameter can also be specified to control the number of measurement sets, each composed of delta count readings, that are repeated under trigger model control (see Section 8 of the Reference Manual). Each set is run independently by restarting the delta mode's advanced moving average algorithm.

Compliance Abort – By enabling (YES) Compliance Abort, Delta operation will abort if the current source goes into compliance. By default, Compliance Abort is disabled (NO).

Cold Switching Mode – By enabling (YES) Cold Switching, Delta operation will zero the current source before leaving the trigger layer prior to sequential trigger model iterations. By default, Cold Switching is disabled (NO).

Operation

Delta operation – front panel

The system configuration for front panel stand-alone operation is shown in [Figure 5-2A](#) on [page 5-5](#).

1. Connections are shown in the following illustrations. All power must be removed from all components in the system before making connections:
 - [Figure 5-3, page 5-6](#) – System connections
 - [Figure 5-5, page 5-8](#) – DUT test connections
2. Configure communications for the Models 2182/2182A and 622x as explained in [“Configuring communications,” page 5-9](#).
3. On the Model 2182/2182A, select the desired measurement range (using the **RANGE** keys) and the integration rate (using the **RATE** key). Rate must be set to an integer value (1, 2, 3, ... up to 50 or 60). If some other rate is selected, it will automatically be changed to 1PLC by the Model 622x during the arming process.
4. On the Model 622x, press **CONFIG** and then **DELTA** to access the CONFIGURE DELTA menu. For details on these settings, see [“Configuration settings” on page 5-15](#).
 - a. Set I-HIGH, I-LOW, DELAY, COUNT, and COMPLIANCE ABORT.
 - b. When finished, use the EXIT key to back out of the menu structure.
5. Set the measurement units.

The basic Delta reading is in volts (which is the default setting). However, it can instead be expressed (and displayed) as an Ohms, Watts, or Siemens reading. See [“Delta” on page 5-13](#) for details.

To set the measurement units, press the **UNITS** key to display the **READING UNITS** menu. Select **VOLTS**, **OHMS**, **WATTS**, or **SIEMENS**. Measurement units can be changed while Delta is running.

6. On the Model 622x, press the **DELTA** key to arm Delta.

The Model 6221 is armed when the message “DELTA ARMED Press TRIG to start” is displayed briefly and the ARM annunciator turns on.
7. On the Model 622x, press the **TRIG** key to start taking Delta readings and send them to the buffer.

If a finite Delta count is being used, the Delta measurements will stop after the last Delta measurement is performed. However, Delta remains armed and can be run again by pressing the **TRIG** key. The new Delta readings will overwrite the old readings in the buffer.

If the infinite Delta count is being used, Delta will run continuously. If the buffer fills, Delta readings will stop being stored, even though Delta continues to run.

8. When finished, press **EXIT** to disarm Delta.
9. On the Model 622x, press **RECALL** to access the Delta readings stored in the buffer.

Operation – PC control

The system configuration for PC control of the Model 622x is shown in [Figure 5-2B](#).

1. Connections are shown in the following illustrations. All power must be removed from all components in the system before making connections:
 - [Figure 5-4, page 5-7](#) – System connections
 - [Figure 5-5, page 5-8](#) – Test connections
2. Configure communications for the Models 2182/2182A and 622x as explained in [“Configuring communications,” page 5-9](#).
3. On the Model 2182/2182A, select the desired measurement range and integration rate. These Model 2182/2182A settings can be made from the front panel or remote programming can be used. Rate must be set to an integer value (1, 2, 3, ... up to 50 or 60). If some other rate is selected, it will automatically be changed to 1PLC by Model 622x during the arming process.

For front panel operation, use the **RANGE** keys to select the measurement range. To set the integration rate, use the **RATE** key.

Commands from the PC to control the Model 2182/2182A are addressed to the Model 622x. Each command is then routed through the Model 622x out the serial port (RS-232) to the Model 2182/2182A. The following command word is used for this communication process:

```
SYSTem:COMMunicate:SERial:SEND <data>
```

Where: <data> is a valid Model 2182/2182A command.

The following query command is used to return the response to a query command sent over the serial port:

```
SYSTem:COMMunicate:SERial:ENTer?
```

When communicating over the serial port, there are no errors reported if a Model 2182/2182A is not properly connected to the Model 622x.

Examples – The following commands demonstrate proper syntax for sending commands and returning responses to queries over the serial port:

```

SYST:COMM:SER:SEND "VOLT:RANG 2"      ' Select 2V range for 2182/
                                         ' 2182A.
SYST:COMM:SER:SEND "VOLT:RANG?"      ' Send range query.
SYST:COMM:SER:ENT?                    ' Return response to query.

SYST:COMM:SER:SEND "VOLT:NPLC 1"     ' Set rate to 1PLC for 2182/
                                         ' 2182A.
SYST:COMM:SER:SEND "VOLT:NPLC?"     ' Send rate query.
SYST:COMM:SER:ENT?                    ' Return response to query.

```

4. **Set measurement units** – Volts are the default units for the Model 622x but can instead be expressed (and displayed) as an Ohms, Watts, or Siemens reading (see “Delta” on [page 5-13](#) for details). The commands to set measurement units are listed in [Table 5-1](#). The following example shows the command to select ohms measurement units:

```
UNIT OHMS          Select ohms measurement units.
```

5. **Set up, arm, and run Delta** – Details on the commands to set up and arm Delta are provided in [Table 5-2](#). The following example demonstrates the proper sequence to set up, arm, and run Delta:

```

*RST                ' Restores 622x defaults.
SOUR:DELT:HIGH 1e-3 ' Sets high source value to 1mA.
SOUR:DELT:DElay 100e-3 ' Sets Delta delay to 100ms.
SOUR:DELT:COUN 1000  ' Sets Delta count to 1000.
SOUR:DELT:CAB ON    ' Enables Compliance Abort.
TRAC:POIN 1000     ' Sets buffer to 1000 points. A
SOUR:DELT:ARM      ' Arms Delta.
INIT:IMM           ' Starts Delta measurements. B

```

- A. Trace points specifies the size of the buffer. Buffer size should be the same value as Delta count. See [Section 6](#) for details on all buffer commands.
- B. The initiate command starts Delta readings. After the specified finite number of Delta readings are performed, Delta will stop running. At this point another initiate command will re-start Delta. New Delta readings will overwrite the old Delta readings in the Model 622x buffer.
- If the Infinity count is set, Delta will run continuously. If the buffer fills, Delta readings will stop being stored, even though Delta continues to run.

Table 5-2
Delta commands

Command	Description	Default
[SOURCE [1]] :DELTA :NVPResent?	Queries connection to 2182A. ¹ 1 = yes, 0 = no	
[SOURCE [1]] :DELTA :HIGH <NRf>	Sets high source value (amps). ² <NRf> = 0 to 105e-3	1e-3
[SOURCE [1]] :DELTA :LOW <NRf>	Sets low source value (amps). ² <NRf> = 0 to -105e-3	-1e3
[SOURCE [1]] :DELTA :DELay <NRf>	Sets Delta delay (seconds). ² <NRf> = 0 to 9999.999 or INFinity	0
[SOURCE [1]] :DELTA :COUNT <NRf>	Sets the number of cycles to run. ² <NRf> = 1 to 65536 (finite count) or INFinity	INF
[SOURCE [1]] :SWEep :COUNT <NRf>	Sets the number of measurement sets to repeat. ² <NRf> = 1 to 65536 (finite count) or INFinity	1
[SOURCE [1]] :DELTA :CSWitch 	Enable cold switching mode. ² = 0 or OFF, 1 or ON	0
[SOURCE [1]] :DELTA :CABort 	Enable or disable Compliance Abort. ² = 0 or OFF, 1 or ON	0
[SOURCE [1]] :DELTA :ARM	Arms Delta. ³	
[SOURCE [1]] :DELTA :ARM?	Queries Delta arm. 1 = armed, 0 = not armed	

1. Use the :NVPResent command to determine if a suitable Model 2182/2182A with the correct firmware revision is properly connected to the RS-232 port. This query command can be used for the system configuration shown in [Figure 5-2B](#) on [page 5-5](#).
2. See [“Configuration settings”](#) on [page 5-15](#) for details on these settings.
3. After setting up Delta using the above setup commands, the :ARM command arms Delta. During the arming process, the Model 622x communicates with the Model 2182/2182A.

When armed, Delta will start when the Model 6221 is triggered. Delta can be “un-armed” by sending the following command: SOURCE:SWEep:ABORT.

The query form for the arm command (SOURCE:DELTA:ARM?) is used to determine if Delta is armed. A returned “1” indicates that Delta is armed. A “0” indicates that Delta is not armed.

If the Model 6221 is already armed for another action (e.g., Differential Conductance or Pulse Delta), the Delta arm command will “un-arm” the other action and arm Delta.

Pulse Delta

Use the Keithley Model 2182A with the Model 6221 to run Pulse Delta.

Model 6221 measurement process

Pulse Delta measurements

For Pulse Delta, the Model 6221 outputs current pulses. Current pulses that have a short pulse width are ideal to test a low-power DUT that is heat sensitive.

By default, Pulse Delta uses a 3-point repeating-average algorithm to calculate readings. Each Pulse Delta reading is calculated using A/D measurements for a low pulse, a high pulse, and another low pulse. The Model 6221 outputs the pulses, and the Model 2182A performs the A/D measurements. As shown in [Figure 5-7](#), every three pulses yields a single Pulse Delta voltage reading.

Figure 5-7
Pulse Delta 3-point measurement technique

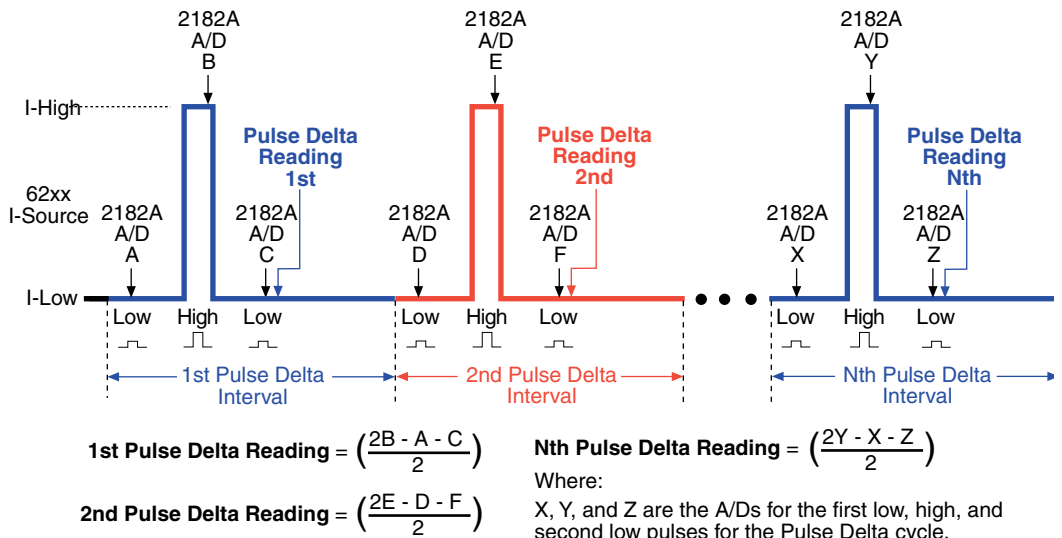

In cases where the high pulse will cause heating of the Device Under Test (DUT), the measurement at the second low pulse could be adversely affected by the heat caused by the high pulse. In that case, the measurement at the second low pulse can be disabled. This does not change the overall timing of the pulse output. Eliminating the second low pulse measurement changes the basic calculation to the following:

$$\text{Pulse Delta} = (2Y - 2X) / 2$$

Where: Y is the measurement at the high pulse.
X is the measurement at the first low pulse.

Measurement units

The fundamental Pulse Delta measurement explained above is in volts. The reading can instead be converted into Ohms (W), Siemens (S), or Power (W). Details on selecting “[Measurement units](#)” are provided on [page 5-11](#).

Peak power and Average power

With Power units selected, a Pulse Delta reading can be expressed (and displayed) as a Peak power reading or an Average power reading. Peak power is the default setting. See “Measurement units” in Section 5 of the Reference Manual for details on Peak power and Average power for Pulse Delta.

Pulse Delta outputs

Pulse Delta output is made up of one or more Pulse Delta cycles. Each cycle is made up of three output pulses (low, high, and low). The time period for a cycle is adjustable and is the same for all cycles. The output pulses have an adjustable pulse width, which is the same for all pulses.

There are two basic Pulse Delta output types: Fixed output and Sweep output. For Fixed output, all high and low pulses are fixed for all Pulse Delta cycles in the test. For Sweep output, the sweep (SWP) function of the Model 6221 is used to output a staircased, logarithmic, or user-specified (custom) pulse sweep.

Fixed output

[Figure 5-8](#) shows one Pulse Delta cycle for a Fixed output. As shown, the Model 6221 outputs a low pulse, a high pulse, and then another low pulse during every Pulse Delta cycle. The pulse width is adjustable and is the same for all high and low pulses. The cycle interval is also adjustable and is based on the set number of power line cycles. The Pulse Delta interval shown in [Figure 5-8](#) is set for 5 PLC (power line cycles), which is the default setting. After the set interval expires, the next Pulse Delta cycle starts (if pulse count is >1).

Pulses are synchronized to the frequency of the power line voltage. When Pulse Delta is started, the three pulses (low, high, and low) are generated on the positive-going edges of the first three power line cycles. For the remaining power line cycles in the interval, the output remains at the I-Low level.

Sweep output

The sweep feature of the Model 6221 can be used to output a series of pulses that allow the use of different levels for the high pulses. Each high pulse returns to the programmed low pulse level. The low level is the same for all pulses.

Like the Fixed output shown in [Figure 5-8](#), a Sweep output is synchronized to the frequency of the power line voltage, and the pulse width is adjustable and is the same for all pulses.

The three available sweeps include (1) staircase sweep, (2) logarithmic sweep, and (3) custom sweep. Examples of these Sweep outputs are shown in [Figure 5-9](#).

Staircase sweep – [Figure 5-9A](#) shows an example of a staircase Sweep output. The sweep is configured to start high pulses at 2mA and staircase to 10mA in 2mA steps. The low pulse level for this sweep is 0mA.

Logarithmic sweep – [Figure 5-9B](#) shows an example of a logarithmic Sweep output. The sweep is configured to output five high pulses (points). The first high pulse starts at 1mA and logarithmically steps to 10mA. The low pulse level for this sweep is 0mA.

Custom sweep – [Figure 5-9C](#) shows an example of a custom Sweep output. The sweep is configured to output five high pulses (points). The level for each high pulse is specified by the user. The high pulse levels for this output are 1mA, 2mA, 4mA, 8mA, and 16mA. The low pulse level for this sweep is 0mA.

Notice that the time period for each Pulse Delta cycle is determined by the set sweep delay. The sweep (including sweep delay) is configured from the CONFIGURE SWEEPS menu. See [Section 4](#) for details.

Figure 5-8
Pulse timing

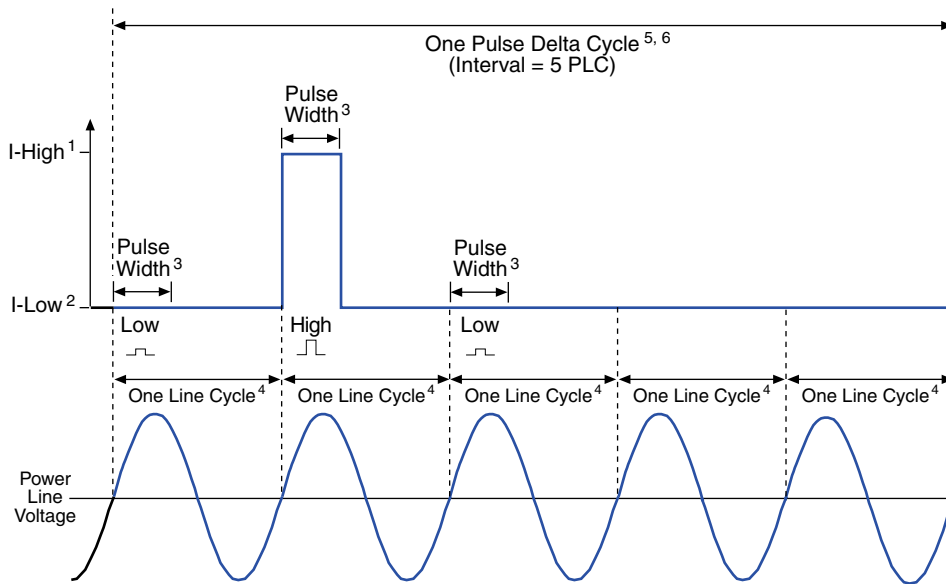

1. I-High can be set from -105mA to +105mA (default is 1mA).
2. I-Low can be set from -105mA to +105mA (default is 0mA).
3. Pulse Width can be set from 50 μ s to 12ms (default is 110 μ s).
4. One 60Hz power line cycle = 16.667ms (1/60)
One 50Hz power line cycle = 20ms (1/50)
5. With Interval set to 5 PLC (power line cycles):
60Hz: One Pulse Delta cycle = 83.33ms (5/60)
50Hz: One Pulse Delta cycle = 100ms (5/50)
6. Interval can be set from 5 to 999999 PLC (default is 5 PLC).

Figure 5-9

Pulse sweep output examples

A) Staircase sweep pulse train: 2 to 10mA in 2mA steps

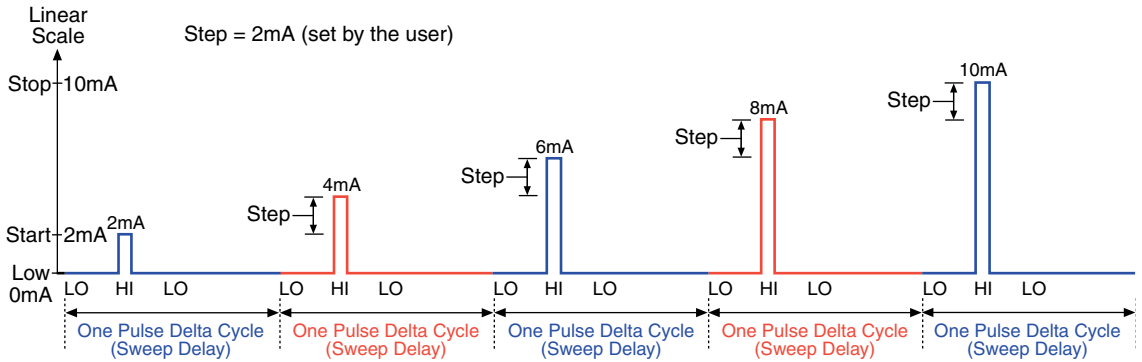

B) Logarithmic sweep pulse train: 1 to 10mA using 5 logarithmic

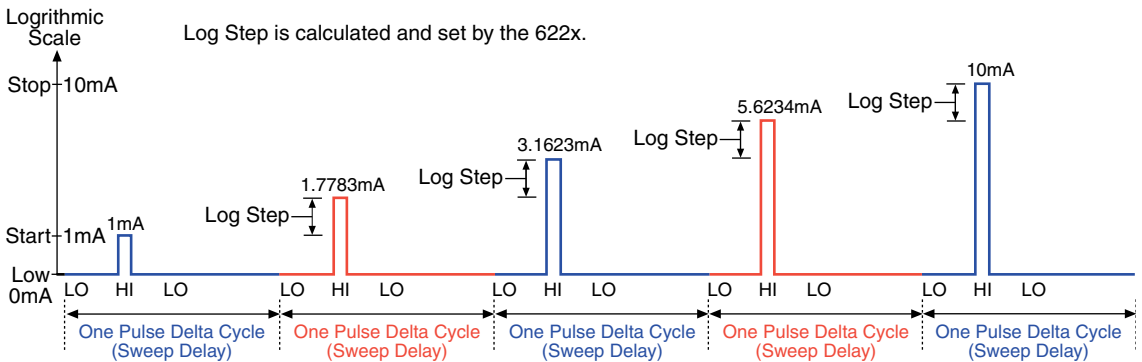

C) Custom sweep pulse train: 1mA, 2mA, 4mA, 8mA, and 16mA (5 points)

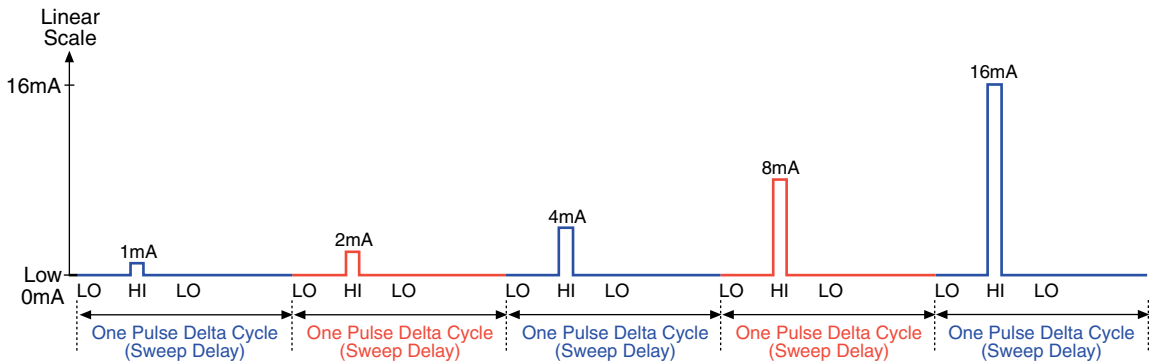

Duty Cycle

Duty cycle defines the ratio between pulse “on” time and pulse “off” time during a Pulse Delta cycle. For example, for a 25% duty cycle, the pulse would be “on” (high) for one-quarter of the cycle, and “off” (0mA low) for three-quarters of the cycle. Pulse Delta cycles with a short duty-cycle can be sourced to prevent heat from adversely affecting the measurement of low power DUT.

When using a 0mA low level (which is the default), the duty cycle for the Pulse Delta cycle is calculated as follows:

$$\text{DutyCycle} = \frac{\text{PulseWidth}}{\text{PulseDeltaCycle}} \cdot 100$$

Where: DutyCycle = Duty cycle expressed as a percent.

PulseWidth = User specified Pulse Width (in seconds).

PulseDeltaCycle = Time period (in seconds) for each Pulse Delta cycle (see “**Pulse Delta cycle time period**”).

Pulse Delta cycle time period

Sweep output – The time period for each Pulse Delta cycle is the same as the sweep delay time that is set by the user when configuring the sweep.

Fixed output – The Pulse Delta cycle (interval) is expressed as the number of power line cycles (PLC). This PLC value must be converted into time (seconds) as follows:

For 60Hz line power:

Pulse Delta cycle time period = Interval setting (PLC) x 16.667ms

For 50Hz line power:

Pulse Delta cycle time period = Interval setting (PLC) x 20ms

Example – For 60Hz line power, the Pulse Delta cycle time period for an Interval setting of 5 PLC is calculated as follows:

$$\begin{aligned} \text{Pulse Delta cycle time period} &= 5 \times 16.667\text{ms} \\ &= 83.33\text{ms} \end{aligned}$$

Configuration settings

Pulse Delta settings from the front panel are described as follows. These parameters are set from the CONFIG PULSE DELTA menu that is accessed by pressing the **CONFIG** key and then the **PULSE** key.

The equivalent remote programming commands to configure Pulse Delta are summarized in [Table 5-3](#).

Fixed output settings

The following parameters are set from the CONFIG PULSE DELTA menu that is accessed by pressing the **CONFIG** key and then the **PULSE** key.

I-Hi and I-Lo

These settings specify the high and low level of the pulses. Each high pulse returns to the programmed low pulse level. Both I-Hi and I-Lo can be set from -105mA to +105mA. The default setting for I-Hi is +1mA, and the default for I-Lo is 0mA.

Width and Source Delay

The pulse width specifies the time period that the output remains at the high and low pulse levels. Pulse width can be set from 50 μ s to 12ms. The default setting for pulse width is 110 μ s.

The source delay is used to allow the pulse to settle before triggering the Model 2182A to perform a measurement conversion (A/D). Source delay can be set from 16 μ s (default setting) to 11.966ms.

The set pulse width and source delay determines the integration rate (measure speed) of the Model 2182A. Integration rate is automatically set when Pulse Delta is armed.

Count

The Pulse Delta count specifies the number of Pulse Delta intervals to perform. Each pulse interval yields one Pulse Delta voltage reading. A finite number (1 to 65,536) can be set or count can be set to Infinity. With infinity set, Pulse Delta will run continuously. The default setting for count is Infinity.

Ranging

For Pulse Delta, the source range can be set for **BEST** (default setting) or **FIXED**. With **BEST** ranging selected, the Model 6221 will select the optimum (lowest) range that will support both the low and high pulse levels. For example, if pulse low is -12mA and pulse high is 10mA, then the 100mA source range will be used.

With **FIXED** ranging selected, the source remains on the range presently selected before arming Pulse Delta. If the selected range is too low, error -221 Settings Conflict will occur.

For **remote programming**, there are two separate commands to set range. Use the SOUR:PDEL:RANG command to set range for a Fixed output, and use the SOUR:SWE:RANG command for the pulse sweep output. Details on these commands are provided in [Table 5-3](#).

Interval

The Pulse Delta cycle time period (interval) is expressed as a number of power line cycles (PLC). For 60Hz one PLC is 16.667ms, and for 50Hz, one PLC is 20ms. Interval can be set from 5 PLC (default setting) to 999999 PLC.

Sweep

The sweep function of the Model 6221 can be enabled (YES) or disabled (NO). When disabled (which is the default setting), the Model 6221 will be configured to output a Fixed output using the programmed high and low pulse levels. When the sweep function is enabled, the Model 6221 will be set to output a configured sweep.

Low Measure

By default, three measurements are performed for every Pulse Delta interval. The Model 2182A measures the voltage at pulse low, pulse high, and finally pulse low as shown in [Figure 5-7](#). As explained in the process for “[Pulse Delta measurements](#)” on [page 5-21](#), a 2-point measurement technique can instead be used when pulse high may cause DUT heating. For the 2-point measurement technique, the voltage measurement for the second low pulse is not performed.

Sweep output settings

The following settings from the CONFIG PULSE DELTA menu are used for pulse sweep output: Width, Sweep, and Low Measure.

The sweep is selected and configured from the CONFIGURE SWEEPS menu that is accessed by pressing the **CONFIG** key and then the **SWP** key. Details on sweeps are provided in [Section 4](#).

It is from the CONFIGURE SWEEPS menu that Source Ranging, Count, and Sweep Delay are set:

Source Ranging

Source range can be set to **BEST** (default setting), **FIXED**, or **AUTO**. The **BEST** and **FIXED** settings are described above in “[Sweep output settings](#)”. The **AUTO** setting is available for a Sweep output. With **AUTO** selected, the instrument automatically selects the optimum (lowest) range for the sweep step.

Delay

Sweep delay defines the Pulse Delta cycle time period (in seconds). The time period is the same for all Pulse Delta cycles. Sweep delay can be set from 1ms to 999999.999s.

Operation

Pulse Delta operation – front panel

The system configuration for front panel stand-alone operation is shown in [Figure 5-2A](#) on [page 5-5](#).

1. Connections are shown in the following illustrations. All power must be removed from all components in the system before making connections:
 - [Figure 5-3, page 5-6](#) – System connections
 - [Figure 5-5, page 5-8](#) – DUT test connections
2. Configure communications for the Models 2182A and 6221 as explained in “[Configuring communications](#)” on [page 5-9](#).
3. On the Model 2182A, select the desired measurement range (using the **RANGE** keys).
4. Perform one the following steps to configure Pulse Delta: Step I for Fixed output, or Step II for Sweep output. “[Configuration settings](#)” are explained on [page 5-26](#).
 - I. **Fixed output** – On the Model 6221, press **CONFIG** and then **PULSE** to access the CONFIG PULSE DELTA menu.
 - a. Set I-HI, I-LO, pulse WIDTH, COUNT, RANGING, source delay (SRC DEL), INTERVAL, disable (**NO**) the SWEEP function, and set the number of low measurements (LOW MEAS) to perform.
 - b. When finished configuring the Fixed output, use the **EXIT** key to back out of the menu structure.
 - II. **Sweep output** – Two configure processes are required for Sweep output:
 - a. On the Model 6221, press **CONFIG** and then **PULSE** to access the CONFIG PULSE DELTA menu. Use this menu to set pulse WIDTH, COUNT, set the number of low measurements (**LOW MEAS**) to perform, and enable (YES) the SWEEP function. When finished, use the **EXIT** key to return to the normal display state.
 - b. On the Model 6221, press **CONFIG** and then **SWP** to access the CONFIGURE SWEEPS menu. Use the TYPE menu item to select and configure the sweep (including the sweep delay), and use the SOURCE RANGING menu item to select ranging (**BEST, FIXED, or AUTO**). When finished, use the **EXIT** key to return to the normal display state.
5. Set the measurement units.

The basic Pulse Delta reading is in volts (which is the default units setting). However, it can instead be expressed (and displayed) as an Ohms, Watts, or Siemens reading. With Watts as the selected units, the reading can be a Peak power reading or an Average power reading. See “[Measurement units](#)” on [page 5-11](#) for details.

To set the measurement units, press the **UNITS** key to display the **READING UNITS** menu. Select **VOLTS**, **OHMS**, **WATTS**, or **SIEMENS**. When **WATTS** is selected, you will then be prompted to select the power units type: **AVERAGE** or **PEAK**. Measurement units can be changed while Pulse Delta is running.

6. On the Model 622x, press the **PULSE** key to arm Pulse Delta. The Model 622x is armed when the message "PULSE MODE ARMED Press TRIG to start" or "PULSE SWEEP ARMED Press TRIG to start" is displayed briefly and the ARM annunciator turns on.
7. On the Model 6221, press the **TRIG** key to start taking Pulse Delta readings and send them to the buffer.
If a finite Pulse Delta count is being used, the Pulse Delta measurements will stop after the last Pulse Delta measurement is performed. However, Pulse Delta remains armed and can be run again by pressing the **TRIG** key. The new Pulse Delta readings will overwrite the old readings in the buffer. If the infinite Pulse Delta count is being used, Pulse Delta will run continuously. If the buffer fills, Pulse Delta readings will stop being stored, even though Pulse Delta continues to run.
8. When finished, press **EXIT** to disarm Pulse Delta.
9. On the Model 6221, press **RECALL** to access the Pulse Delta readings stored in the buffer.

Operation – PC control

The system configuration for PC control of the Model 6221 is shown in [Figure 5-2B](#) on [page 5-5](#).

1. Connections are shown in the following illustrations. All power must be removed from all components in the system before making connections:
 - [Figure 5-4, page 5-7](#) – System connections
 - [Figure 5-5, page 5-8](#) – Test connections
2. Configure communications for the Models 2182A and 6221 as explained in "[Configuring communications](#)" on [page 5-9](#).
3. On the Model 2182A, select the desired measurement range. For front panel operation, use the **RANGE** keys to select the measurement range.

Commands from the PC to control the Model 2182A are addressed to the Model 622x. Each command is then routed through the Model 622x out the serial port (RS-232) to the Model 2182A. The following command word is used for this communication process:

```
SYSTem:COMMunicate:SERial:SEND <data>
```

Where: <data> is a valid Model 2182A command.

The following query command is used to return the response to a query command sent over the serial port:

```
SYSTem:COMMunicate:SERial:ENTer?
```

When communicating over the serial port, there are no errors reported if a Model 2182A is not connected to the serial port.

Examples – The following commands demonstrate proper syntax for sending commands and returning responses to queries over the serial port:

```
SYST:COMM:SER:SEND "VOLT:RANG 1"      ' Select 1V range for 2182A.
SYST:COMM:SER:SEND "VOLT:RANG?"      ' Send range query.
SYST:COMM:SER:ENT?                    ' Return response to query.
```

4. **Set measurement units** – Volts are the default units for the Model 6221 but can instead be expressed (and displayed) as an Ohms, Watts, or Siemens reading (see [“Measurement units”](#) on [page 5-11](#) for details). The commands to set measurement units are listed in [Table 5-1](#). The following example shows the command sequence to select average power measurement units:

```
UNIT W                                ' Select power (Watts) measurement units.
UNIT:POWer AVERAge                    ' Select Average power type.
```

5. **Set up, arm, and run Pulse Delta** – Details on the commands to set up and arm Pulse Delta are provided in [Table 5-3](#). The following example demonstrates the proper sequence to set up, arm, and run a Fixed output:

```
*RST                                  ' Restores 6221 defaults.
SOUR:PDEL:HIGH 10e-3                  ' Sets pulse high value to 10mA.
SOUR:PDEL:LOW 0                        ' Sets pulse low value to 0mA.
SOUR:PDEL:WIDT 500e-6                 ' Sets pulse width to 500µs.
SOUR:PDEL:SDEL 100e-6                 ' Sets source delay to 100µs.
SOUR:PDEL:COUN 200                     ' Sets pulse count to 200.
SOUR:PDEL:RANG BEST                    ' Selects the best source range.
SOUR:PDEL:INT 10                       ' Sets pulse interval to 10 PLC.
SOUR:PDEL:SWE OFF                      ' Disables sweep function.
SOUR:PDEL:LME 2                         ' Set for two low pulse measurements.
TRAC:POIN 200                          ' Sets buffer to 200 points. A
SOUR:PDEL:ARM                           ' Arms Pulse Delta.
INIT:IMM                                ' Starts Pulse Delta measurements. B
```

- A. Trace points specifies the size of the buffer. Buffer size should be the same value as Pulse Delta count. See [Section 6](#) for details on all buffer commands.

- B. The initiate command starts Pulse Delta readings. After the specified finite number of Pulse Delta readings are performed, Pulse Delta will stop running. At this point another initiate command will re-start Pulse Delta. New Pulse Delta readings will overwrite the old Pulse Delta readings in the Model 6221 buffer.
- If the Infinity count is set, Pulse Delta will run continuously. If the buffer fills, Pulse Delta readings will stop being stored, even though Pulse Delta continues to run.
6. **Read Pulse Delta readings** – While Pulse Delta is running, the latest Model 2182A Pulse Delta reading can be read by the Model 6221 using the following command:

SENS : DATA? ' Reads the latest Pulse Delta reading.

The above read command reads the last Pulse Delta reading that was performed by the Model 2182A. If this command is sent before a new reading is available, the last Pulse Delta reading will again be returned.

NOTE If a read command is sent when Pulse Delta is not running, error -221 Settings Conflict will occur.

7. When finished with Pulse Delta, it can be disarmed by sending the following command:
- SOUR : SWE : ABOR ' Stops Pulse Delta and places the Model 2182A in the local mode.
8. **Recall stored Pulse Delta readings** – Model 2182A Pulse Delta readings were sent to the buffer of the Model 6221. Send the following read command to read the buffer:
- TRACe : DATA? ' Read Pulse Delta readings stored in 6221 buffer.

Setup commands

Pulse Delta setup and arm commands

Commands sent from the PC to the Model 6221 to set up and arm Pulse Delta are listed in [Table 5-3](#).

Table 5-3
Pulse Delta commands

Command	Description	Default
SOURce [1] :PDELta:NVPresent?	Queries if 2182A is connected. ¹ 1 = yes, 0 = no	
SOURce [1] :PDELta:HIGH <NRf>	Sets high pulse value (amps). ² <NRf> = -105e-3 to 105e-3	1e-3
SOURce [1] :PDELta:LOW <NRf>	Sets low pulse value (amps). ² <NRf> = -105e-3 to 105e-3	0
SOURce [1] :PDELta:WIDTh <NRf>	Sets pulse width (seconds). ² <NRf> = 50e-6 to 12e-3	110e-6
SOURce [1] :PDELta:SDElay <NRf>	Sets pulse delay (seconds). ^{2, 3} <NRf> = 16e-6 to 11.996e-3	16e-6
SOURce [1] :PDELta:RANGing <name>	Selects fixed pulse range. ^{2, 4} <name> = BEST or FIXEd	BEST
SOURce [1] :SWEep:RANGing <name>	Selects pulse sweep range. ^{2, 4} <name> = AUTO, BEST or FIXEd	BEST
SOURce [1] :PDELta:COUNT <NRf>	Sets the number of Pulse Delta intervals to perform. ² <NRf> = 1 to 65536 (finite count) or INFinity count.	INF
SOURce [1] :PDELta:INTerval <NRf>	Sets cycle time for fixed pulse (PLCs). ² <NRf> = 5 to 999999	5
SOURce [1] :DElay <NRf>	Sets cycle time for lin/log sweep (seconds). ^{2, 3} <NRf> = 1e-3 to 999999.999	1
SOURce [1] :LIST:DElay <NRf> [, NRf, ...<NRf>]	Sets cycle time for custom sweep (seconds). ^{2, 3} <NRf> = 1e-3 to 999999.999	1
SOURce [1] :PDELta:SWEep [:STATe] 	Enable or disable Sweep output mode. ² = ON or OFF	OFF
SOURce [1] :PDELta:LMEasure <NRf>	Set number of low measurements. ² <NRf> = 1 or 2	2
SOURce [1] :PDELta:ARM	Arms Pulse Delta. ⁴	
SOURce [1] :PDELta:ARM?	Queries Pulse Delta arm. 1 = armed, 0 = not armed	

1. Use the :NVPresent command to determine if a suitable Model 2182A with the correct firmware revision is properly connected to the RS-232 port. The RS-232 cannot be the selected interface for the Model 6221. If it is, this query will generate error -221 Settings Conflict.
2. Details on the “[Configuration settings](#)” are provided on [page 5-26](#).
3. When using a Fixed output, use the SOUR:PDEL:INT command to set the Pulse Delta cycle time period (in PLCs).

When using Sweep output, use the SOUR:DEL command to set the Pulse Delta cycle time period (in seconds) for a linear or log sweep. For a custom sweep, use the SOUR:LIST:DEL command to cycle time (in seconds). See [Section 4](#) for details on sweeps.

4. When using a Fixed output, use the SOUR:PDEL:RANG command to set the source range. When using a Sweep output, use the SOUR:SWE:RANG command to set range.
5. After setting up Pulse Delta using the setup commands, the :ARM command arms Pulse Delta. During the arming process, the Model 622x communicates with the Model 2182A.

When armed, Pulse Delta will start when the Model 6221 is triggered. Pulse Delta can be “un-armed” by sending the following command:

```
SOURce:SWEep:ABORT.
```

The query form for the arm command (SOUR:PDEL:ARM?) is used to determine if Pulse Delta is armed. A returned “1” indicates that Pulse Delta is armed. A “0” indicates that Pulse Delta is not armed.

If the Model 6221 is already armed for another action (e.g., Differential Conductance or Delta), the Pulse Delta arm command will “un-arm” the other action and arm Pulse Delta.

Differential Conductance

Differential measurements can be used to study the individual slopes of an I-V (or V-I) curve. By applying a known differential current (dI) to a device, differential voltage (dV) measurements can be performed. With dI and dV known, differential conductance (dG) and differential resistance (dR) can be calculated.

Model 622x measurement process

This measurement process is used to eliminate the effects of thermal EMFs, and a 3-point moving average calculation algorithm is used to provide more accurate readings.

The differential measurement process is shown in [Figure 5-10](#). The Model 622x is configured to output a stepped sweep with a specified Delta, which is the differential current (dI). As shown in the illustration, Delta is added to and subtracted from each subsequent step in the sweep. The solid line is the actual output of the Model 622x.

As shown, each differential voltage calculation (dV Calc) uses the three previous Model 2182/2182A A/D measurement conversions. Keep in mind that dI (Delta) is the same for all calc points. With dI known and dV calculated, the Model 622x can also calculate, display, and store the differential conductance (dG) or differential resistance (dR) for each calculated point.

Figure 5-10
Differential Conductance measurement process

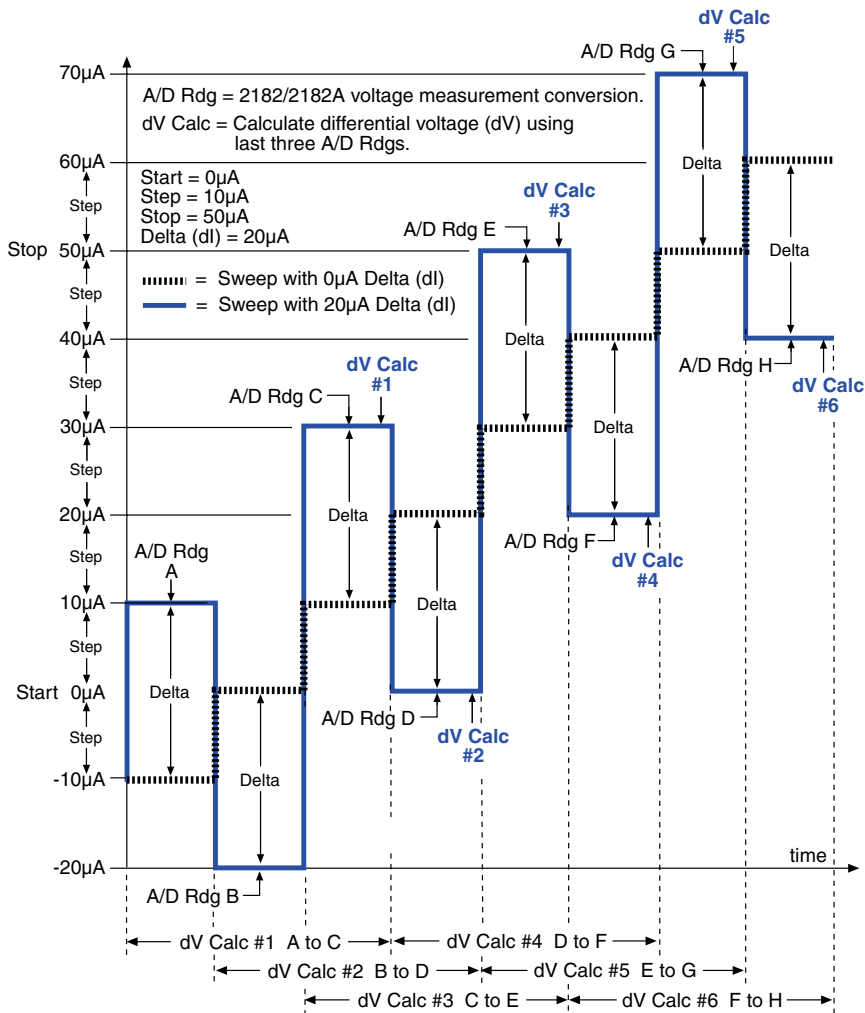

dV Calculations – The following equations are used by the 622x to calculate differential voltage (dV). To calculate dV, points A through H are 2182/2182A voltage measurements (A/D readings).

$$\begin{aligned}
 dV \#1 &= \frac{[(A-B)/2] + [(C-B)/2]}{2} \cdot (-1)^0 & dV \#4 &= \frac{[(D-E)/2] + [(F-E)/2]}{2} \cdot (-1)^3 \\
 dV \#2 &= \frac{[(B-C)/2] + [(D-C)/2]}{2} \cdot (-1)^1 & dV \#5 &= \frac{[(E-F)/2] + [(G-F)/2]}{2} \cdot (-1)^4 \\
 dV \#3 &= \frac{[(C-D)/2] + [(E-D)/2]}{2} \cdot (-1)^2 & dV \#6 &= \frac{[(F-G)/2] + [(H-G)/2]}{2} \cdot (-1)^5
 \end{aligned}$$

dG and dR Calculations – With dl known (dl = Delta) and dV calculated, the 622x can then calculate differential conductance (dG) or differential resistance (dR).

With G units selected, readings are calculated as follows: dG = dl/dV.
 With R units selected, readings are calculated as follows: dR = dV/dl.

Differential Conductance calculations

dV calculations

While the dV calculations for the first six dV readings are shown in [Figure 5-10](#), the following formula can be used to calculate any dV reading in the test:

$$dV = \frac{\frac{(X-Y)}{2} + \frac{(Z-Y)}{2}}{2} \cdot (-1)^n$$

Where: X, Y, and Z are the three A/D measurements for a dV reading.
 $n = \text{Reading Number} - 1$

Example – Calculate the 21st dV reading:

X, Y, and Z are the three A/D measurements for the 21st dV reading.

$$\begin{aligned} n &= \text{Reading Number} - 1 \\ &= 21 - 1 \\ &= 20 \end{aligned}$$

Therefore:

$$\begin{aligned} dV &= \frac{\frac{(X-Y)}{2} + \frac{(Z-Y)}{2}}{2} \cdot (-1)^{20} \\ &= \frac{\frac{(X-Y)}{2} + \frac{(Z-Y)}{2}}{2} \end{aligned}$$

The $(-1)^n$ term in the dV calculation is used for polarity reversal of every other calculated dV reading. This makes all calculated dV readings in the test the same polarity.

Simplified dV calculation

The above dV calculation can be simplified as follows:

$$dV = \frac{\frac{X-Y+Z-Y}{2}}{2} \cdot (-1)^n$$

$$dV = \frac{X-2Y+Z}{4} \cdot (-1)^n$$

Measurement units

The fundamental measurement for Differential Conductance is differential voltage (dV). However, the dV reading can be converted into a differential conductance (dG), differential resistance (dR), or power (Watts) reading. See [page 5-11](#) for details on selecting “[Measurement units](#)”.

With Ohms (dR) or Siemens (dG) measurement units selected, the reading is calculated as follows:

$$dR = dV/dI$$

$$dG = dI/dV$$

Power – With Power measurement units selected, power is calculated using Average Voltage and Average Current. Details on Differential Conductance Power calculations are provided in Section 5 of the Reference Manual (see “Average Voltage and Power”).

Configuration settings

Differential Conductance settings from the front panel are described as follows. These parameters are set from the DIFF CONDUCTANCE menu, which is accessed by pressing the **CONFIG** key and then the **COND** key.

The equivalent remote programming commands to configure Differential Conductance are summarized in [Table 5-4](#).

Step – The step size specifies the size increment for each step of the sweep. In [Figure 5-10](#), the 10 μ A steps are shown by the dashed line. If the step size is set to be larger than the start-stop interval, the step size will be readjusted to provide a 100-point Differential Conductance sweep.

Step is a magnitude and is therefore always set as a positive value. Step can be set from 0 to 105mA. The default step size is 1 μ A.

Start – The start level for the sweep applies to the middle step of the first cycle. As shown in [Figure 5-10](#), the 0 μ A Start level is actually the second step of the sweep. The start level can be set from -105mA to +105mA. The default start level is -10 μ A.

Stop – The stop level for the sweep applies to the middle step of the last cycle. As shown in [Figure 5-10](#), the 50 μ A Stop level is actually the second last step of the sweep. The stop level can be set from -105mA to +105mA. The default start level is +10 μ A.

Delta – The specified Delta is the differential current (dI) for the sweep. It is alternately added to and subtracted from each subsequent step in the sweep. As shown in [Figure 5-10](#), 10 μ A is added to the odd numbered steps and then subtracted from the even numbered steps. Model 2182/2182A A/D readings are performed at each stepped delta level. Delta is a magnitude and is therefore always set as a positive value. Delta can be set from 0 to 105mA. The default Delta setting is 1 μ A.

Delay – The delay for Differential Conductance is used to allow the current source to settle when the output changes to the next stepped delta level. This delay occurs after a trigger from the Model 2182/2182A is received. Delay can be set from 1ms to 9999.999s. The default delay setting is 2ms.

Compliance Abort – By enabling (**YES**) Compliance Abort, Differential Conductance operation will abort if the current source goes into compliance. By default, Compliance Abort is disabled (**NO**).

Details on setting the sweep parameters are explained in [“Operation”, page 5-38](#).

NOTE The source range for the Model 622x is automatically set to the best fixed range when Differential Conductance is armed.

Operation

Operation – front panel

The system configuration for front panel stand-alone operation is shown in [Figure 5-2A on page 5-5](#).

1. Connections are shown in the following illustrations. All power must be removed from all components in the system before making connections:
 - [Figure 5-3, page 5-6](#) – System connections
 - [Figure 5-5, page 5-8](#) – DUT test connections
2. Configure communications for the Models 2182/2182A and 622x as explained in [“Configuring communications,” page 5-9](#).
3. On the Model 2182/2182A, select the desired measurement range (using the **RANGE** keys) and the integration rate (using the **RATE** key). Rate must be set to an integer value (1, 2, 3, ... up to 50 or 60). If some other rate is selected, it will automatically be changed to 1PLC by the Model 622x during the arming process.
4. On the Model 622x, press **CONFIG** and then **COND** to access the DIFF CONDUCTANCE menu. See [“Configuration settings” on page 5-37](#) for details on these settings.
 - a. Set the START, STOP, STEP, DELTA, DELAY, and compliance abort (CMPL ABORT) parameters.
 - b. When finished, use the EXIT key to back out of the menu structure.
5. **Set the measurement units.**

The basic Differential Conductance reading is in volts (which is the default setting). However, it can instead be expressed (and displayed) as an Ohms, Watts or Siemens reading. See [“Measurement units” on page 5-11](#) for details.

To set the measurement units, press the **UNITS** key to display the **READING UNITS** menu. Select **VOLTS**, **OHMS**, **WATTS**, or **SIEMENS**. Measurement units can be changed while Differential Conductance is running.

6. On the Model 622x, press the **COND** key to arm Differential Conductance. The Model 6221 is armed when the message "DIFF COND ARMED Press TRIG to start" is displayed briefly and the ARM annunciator turns on.
7. On the Model 622x, press the **TRIG** key to start taking Differential Conductance readings and send them to the buffer.
Differential Conductance measurements will stop after the last A/D measurement is performed. However, Differential Conductance remains armed and can be run again by pressing the **TRIG** key. The new Differential Conductance readings will overwrite the old readings in the buffer.
8. When finished, press **EXIT** to disarm Differential Conductance.
9. On the Model 622x, press **RECALL** to access the Differential Conductance readings stored in the buffer.

Operation – PC control

The system configuration for PC control of the Model 622x is shown in [Figure 5-2B](#).

1. Connections are shown in the following illustrations. All power must be removed from all components in the system before making connections:
 - [Figure 5-4, page 5-7](#) – System connections
 - [Figure 5-5, page 5-8](#) – Test connections
2. Configure communications for the Models 2182/2182A and 622x as explained in "[Configuring communications,](#)" [page 5-9](#).
3. On the Model 2182/2182A, select the desired measurement range and integration rate. These Model 2182/2182A settings can be made from the front panel or remote programming can be used. Rate must be set to an integer value (1, 2, 3, ... up to 50 or 60). If some other rate is selected, it will automatically be changed to 1PLC by Model 622x during the arming process.

For front panel operation, use the **RANGE** keys to select the measurement range. To set the integration rate, use the **RATE** key.

Commands from the PC to control the Model 2182/2182A are addressed to the Model 622x. Each command is then routed through the Model 622x out the serial port (RS-232) to the Model 2182/2182A. The following command word is used for this communication process:

```
SYSTem:COMMunicate:SERial:SEND <data>
```

Where: <data> is a valid Model 2182/2182A command.

The following query command is used to return the response to a query command sent over the serial port:

```
SYSTem:COMMunicate:SERial:ENTer?
```

When communicating over the serial port, there are no errors reported if a Model 2182/2182A is not connected to the serial port.

Examples – The following commands demonstrate proper syntax for sending commands and returning responses to queries over the serial port:

```
SYST:COMM:SER:SEND "VOLT:RANG 2"      ' Select 2V range for 2182/
                                         ' 2182A.
SYST:COMM:SER:SEND "VOLT:RANG?"      ' Send range query.
SYST:COMM:SER:ENT?                    ' Return response to query.

SYST:COMM:SER:SEND "VOLT:NPLC 1"      ' Set rate to 1PLC for 2182/
                                         ' 2182A.
SYST:COMM:SER:SEND "VOLT:NPLC?"      ' Send rate query.
SYST:COMM:SER:ENT?                    ' Return response to query.
```

- Set measurement units** – Volts are the default units for the Model 622x but can instead be expressed (and displayed) as an Ohms, Watts, or Siemens reading (see “[Measurement units](#)” on [page 5-11](#) for details). The commands to set measurement units are listed in [Table 5-1](#). The following example shows the command to select conductance (Siemens) measurement units:

```
UNIT S                                ' Select Siemens measurement units.
```

- Set up, arm, and run Differential Conductance** – Details on the commands to set up and arm Differential Conductance are provided in [Table 5-4](#). The following demonstrates the proper command sequence to set up, arm, and run Differential Conductance for the Example in [Figure 5-10](#):

```
*RST                                  ' Restores 622x defaults.
SOUR:DCON:START 0                     ' Sets start value to 0µA.
SOUR:DCON:STEP 10e-6                   ' Sets step size to 10µA.
SOUR:DCON:STOP 50e-6                   ' Sets stop value to 50µA.
SOUR:DCON:DELTA 20e-6                  ' Sets delta value to 20µA.
SOUR:DCON:DELay 1e-3                   ' Sets delay to 1ms.
SOUR:DCON:CAB ON                       ' Enables Compliance Abort.
TRAC:POIN 6                            ' Sets buffer size to six points. A
SOUR:DCON:ARM                          ' Arms Differential Conductance.
INIT:IMM                                ' Starts measurements. B
```

- A. Trace points specifies the size of the buffer. Buffer size should be the same value as the number of Differential Conductance readings in the test. See [Section 6](#) for details on all buffer commands.
 - B. The initiate command starts Differential Conductance readings. After all Differential Conductance readings are performed, Differential Conductance will stop running. At this point another initiate command will re-start Differential Conductance. New Differential Conductance readings will overwrite the old Differential Conductance readings in the Model 622x buffer.
6. **Read Differential Conductance readings** – While Differential Conductance is running, the latest Model 2182/2182A reading can be read by the Model 622x using the following command:

SENS : DATA? ' Reads the latest reading.

The above read command reads the last Differential Conductance reading that was performed by the Model 2182/2182A. If this command is sent before a new reading is available, the last Differential Conductance reading will again be returned.

NOTE If a read command is sent when Differential Conductance is not running, error -221 Settings Conflict will occur.

7. When finished with Differential Conductance, it can be disarmed by sending the following command:

SOUR : SWE : ABOR ' Stops Differential Conductance and places the
' Model 2182/2182A in the local mode.

8. **Recall stored Differential Conductance readings** – Model 2182/2182A Differential Conductance readings were sent to the buffer of the Model 622x. Send the following read command to read the buffer:

TRACe : DATA? ' Read Differential Conductance buffer readings.

Setup and arm commands

Commands sent from the PC to the Model 622x to set up and arm Differential Conductance are listed in [Table 5-4](#).

Table 5-4
Differential Conductance commands

Command	Description	Default
SOURce [1] :DCONductance:NVPResent?	Queries if 2182/2182A is connected. ¹ 1 = yes, 0 = no	
SOURce [1] :DCONductance:START <NRf>	Sets start value (amps). ² <NRf> = -105e-3 to 105e-3	-10e-6
SOURce [1] :DCONductance:STEP <NRf>	Sets step size (amps). ² <NRf> = 0 to 105e-3	1e-6
SOURce [1] :DCONductance:STOP <NRf>	Sets stop value (amps). ² <NRf> = -105e-3 to 105e-3	10e-6
SOURce [1] :DCONductance:DELTA <NRf>	Sets delta value (amps). ² <NRf> = 0 to 105e-3	1e-6
SOURce [1] :DCONductance:DELAy <NRf>	Sets delay (seconds). ² <NRf> = 1e-3 to 9999.999	0.002
SOURce [1] :DCONductance:CABort 	Enable or disable Compliance Abort. ² = 0 or OFF, 1 or ON	0
SOURce [1] :DCONductance:ARM	Arms Differential Conductance. ³	
SOURce [1] :DCONductance:ARM?	Queries Diff Cond arm. ³ 1 = armed, 0 = not armed.	
SOURce [1] :DCONductance:NVZero?	Queries V-zero value acquired from 2182/2182A. ⁴	

1. Use the :NVPR? command to determine if a suitable Model 2182/2182A with the correct firmware revision is properly connected to the RS-232 port. This query command can be used for the system configuration shown in [Figure 5-2B](#) on [page 5-5](#).
The RS-232 cannot be the selected interface for the Model 6221. If it is, this query will generate error -221 Settings Conflict.
2. See “[Configuration settings](#)” on [page 5-37](#) for more information on these settings (:START, :STEP, :STOP, :DELTA, :DELAy, and :CABort).
3. After setting up Differential Conductance using the above setup commands, the :ARM command arms Differential Conductance. During the arming process, the Model 622x communicates with the Model 2182/2182A.
When armed, Differential Conductance will start when the Model 6221 is triggered. Differential Conductance can be “un-armed” by sending the following command: SOURce:SWEep:ABORT.

The query form for the arm command (SOUR:DCON:ARM?) is used determine if Differential Conductance is armed. A returned "1" indicates that Differential Conductance is armed. A "0" indicates that Differential Conductance is not armed.

If the Model 6221 is already armed for another action (e.g., Delta or Pulse Delta), the Differential Conductance arm command will "un-arm" the other action and arm Differential Conductance.

4. During the arming process, the Model 622x acquires the offset voltage (V-zero) value of the Model 2182/2182A. The Model 622x factors this value into the calculation for Differential Conductance voltage.

Averaging Filter, Math, and Buffer

Section 6 topics

Averaging filter, page 6-2

Averaging filter characteristics, page 6-2

Filter setup and control, page 6-4

Remote programming – Averaging filter, page 6-4

Math, page 6-7

$mX+b$ and $m/X+b$ (reciprocal), page 6-5

Configuring $mX+b$ and $m/X+b$, page 6-6

Remote programming – Math, page 6-6

Buffer, page 6-7

Buffer characteristics, page 6-7

Storing readings, page 6-8

Recall, page 6-8

NOTE This section only applies to a Model 622x that is being used with a Model 2182/2182A to perform Delta, Pulse Delta, or Differential Conductance measurements.

NOTE The information in this section is an abbreviated version of the information in Section 6 of the Reference Manual. Refer to Section 6 of the Reference Manual for complete details and additional information that is not provided in this manual.

Averaging filter

The average filter can be used with Delta, Pulse Delta, and Differential Conductance. There are two types of averaging filter: moving and repeating. “Filter type” is explained on [page 6-3](#).

The averaging filter stabilizes noisy delta measurements caused by noisy input signals. For Delta, Pulse Delta, and Differential Conductance, readings from the Model 2182/2182A are processed by the Model 622x as delta voltage readings. These delta readings can then be filtered by the Model 622x.

[Table 6-1](#) lists the filter types that can be used with the various delta tests (Yes) and which cannot (No). Note that the filter must be enabled before arming the delta test.

Table 6-1
Average filter types

Average Filter	Moving	Repeating
Delta	Yes	Yes
Pulse Delta: Fixed output	Yes	Yes
Sweep output	Yes	No ²
Differential Conductance	No ¹	Yes

1. If the moving average filter is enabled when Differential Conductance is armed, the filter type will change to repeating.
2. If the repeating average filter is enabled when Pulse Delta (Sweep output) is armed, the filter type will change to moving.

Averaging filter characteristics

Filter count

The filter count specifies how many delta readings (within the filter window) to place in the memory stack. Keep in mind that there are three A/Ds for every Delta and Differential Conductance reading, and two or three A/Ds for every Pulse Delta reading.

When the stack is full, the readings are averaged to calculate the final filtered delta reading. The filter count can be set from 2 to 300. However, only readings within the filter window will be displayed and stored, or transmitted (see “[Filter window](#)” on [page 6-4](#) for details).

Filter type

There are two averaging filter types: moving and repeating.

Moving filter

Basic moving filter operation – For the moving filter, every delta reading yields a filtered delta reading. Every time a delta reading is placed in the buffer stack, the readings in the stack are averaged to yield a single filtered reading. The stack type is first-in, first-out. After the stack fills, the newest reading conversion replaces the oldest. Note that the instrument does not wait for the stack to fill before releasing readings.

Delta and Pulse Delta – As shown in [Table 6-1](#), the moving average filter can be used with Delta and Pulse Delta.

Keep in mind that when using the averaging filter, a settled filter reading is not available until after the filter stack is filled. The filter count sets the filter stack size.

When Delta or Pulse Delta is started, the filter stack is allowed to fill before the first filtered Delta or Pulse Delta reading is stored in the buffer. Therefore, the total number of Delta or Pulse Delta cycles that are performed is calculated as follows:

$$\text{Total Number of Cycles} = \text{Moving Filter Count} + \text{Cycle Count}$$

Repeating filter

Basic repeating filter operation – As shown in [Table 6-1](#), the repeating average filter can be used with Delta, Pulse Delta (fixed output), and Differential Conductance.

The repeating filter takes a specified number (count) of reading conversions, averages them, and yields a reading. It then flushes its stack and starts over.

The filter stack must be filled with delta readings and then averaged to yield (and store) one filtered delta reading. The stack is emptied, and the “fill and average” process is repeated to yield (and store) another filtered reading.

This “fill and average” process is repeated for every specified delta cycle. For example, assume the repeating average filter count is 10 and the delta test is configured to perform 25 cycles. For these test parameters, 250 delta cycles will be performed to store 25 filtered delta readings in the buffer.

Differential Conductance – When using the repeating filter, the actual step size run for the test is the programmed step size divided by the filter count:

$$\text{Step Size (repeating filter)} = \text{Programmed Step Size} / \text{Filter Count}$$

For example, assume the programmed step size is 10 μ A and the Filter Count is 10. When the Differential Conductance test is run, the actual step size will be 1 μ A (10 μ A / 10).

Filter window

The averaging filter uses a “noise” window to control filter threshold. As long as the signal remains within the selected window, A/D conversions continue to be placed in the stack. If the signal changes to a value outside the window, the filter resets, and the filtering process starts over.

The noise window, which is expressed as a percentage of measurement range, allows a faster response time to large signal step changes (e.g., sweep step). A reading conversion outside the plus or minus noise window fills the filter stack immediately.

If the noise does not exceed the selected window, the reading is based on the average of the reading conversions. If the noise does exceed the selected window, the reading is a single reading conversion, and new averaging starts from this point.

The window can only be set remotely and can be assigned any value from 0.00% to 10%. The filter window is expressed as a percent of range. For example, with the Model 2182/2182A on the 10V range, a 10% window means that the filter window is $\pm 1V$.

Filter setup and control

When the averaging filter is enabled, the **FILT** annunciator turns on. For **front panel operation**, the **AVG** key toggles the state of the averaging filter. The filter can be configured while it is enabled or disabled.

To configure the filter, press **CONFIG** then **AVG**. From the **TYPE** menu item, select the **MOVING** or **REPEAT** filter and press **ENTER**. From the **COUNT** menu item, set the filter count (2 to 300) and press **ENTER**. Use the **EXIT** key to return to the normal display state.

Remote programming – Averaging filter

The commands for averaging filter setup and control are listed in [Table 6-2](#). A programming example follows the table.

Table 6-2
Averaging filter commands

Command	Description	Default
SENSe[1]:AVERage:TCONtrol <name>	Select filter control. <name> = MOVing or REPeat.	MOV
SENSe[1]:AVERage:WINDow <NRf>	Set filter window as % of range: <NRf> = 0 to 10 (0 selects no window)	0.0
SENSe[1]:AVERage:COUNt <NRf>	Specify filter count (size). <NRf> = 2 to 300	10
SENSe[1]:AVERage[:STATe] 	Enable or disable averaging filter.	OFF

Programming example — Repeating average filter

This command sequence configures and enables the repeating filter for Differential Conductance:

```

SENS:AVER:TCON REP      ' Select the repeating average filter.
SENS:AVER:WIND 1        ' Set filter window to 1%.
SENS:AVER:COUN 20       ' Set filter count to 20.
SENS:AVER ON            ' Enable the repeating average filter.

```

Math

$mX+b$ and $m/X+b$ (reciprocal)

These math functions affect the results of the Delta, Pulse Delta, or Differential Conductance operations. Details on the delta operations are covered in [Section 5](#).

$mX+b$ and $m/X+b$ manipulate delta readings (X) mathematically according to the following calculations:

$$Y = mX+b$$

$$Y = m/X+b$$

Where: X is the normal delta reading.
 m and b are user-entered constants for scale factor and offset.
 Y is the displayed result.

NOTE Changing the “m” or “b” for $mX+b$ also changes it for $m/X+b$.

Configuring $mX+b$ and $m/X+b$

To select and configure $mX+b$ and $m/X+b$ from the front panel, press **CONFIG** then **MATH**. Select the math function (**MX+B** or **M/X+B**), then enter the required parameters (m and b). Once a math function is selected, press the **MATH** key to toggle math on or off. The MATH annunciator will turn on to indicate that the math function is enabled.

Remote programming – Math

Commands for $mX+b$ and $m/X+b$ math calculations are listed in [Table 6-3](#).

Table 6-3

Math commands

Command	Description	Default
CALCulate[1]:FORMat <name>	Select math format. <name> = NONE, MXB or RECiprocal	MXB
CALCulate[1]:KMATH:MMFactor <NRf>	Set “m” factor for $mX+b$ and $m/X+b$. <NRf> = -9.99999e20 to 9.99999e20	1.0
CALCulate[1]:KMATH:MA1Factor <NRf>	Set “m” factor for $mX+b$ and $m/X+b$. (same as MMFactor)	1.0
CALCulate[1]:KMATH:MBFactor <NRf>	Set “b” factor for $mX+b$ and $m/X+b$. <NRf> = -9.99999e20 to 9.99999e20	0.0
CALCulate[1]:KMATH:MA0Factor <NRf>	Set “b” factor for $mX+b$ and $m/X+b$. (same as MBFactor)	0.0
CALCulate[1]:STATe 	Enable or disable CALC1 calculation	OFF
CALCulate[1]:DATA[:LATest]?	Return the latest CALC1 result.	
CALCulate[1]:DATA:FRESH?	Same as CALC1:DATA? except a reading can only be returned once.	

Programming example — $mX+b$

This command sequence performs a single $mX+b$ calculation and displays the result on the computer CRT. Note that Delta, Pulse Delta, or Differential Conductance must be running when the CALC1 read command is sent.

```

CALC1:FORM MXB           ' Select mX+b math format.
CALC1:KMAT:MMF 2e-3      ' Set scale factor (M) to 2e-3.
CALC1:KMAT:MBF 5e-4      ' Set offset (B) to 5e-4.
CALC1:STAT ON           ' Enable CALC1 (math).
CALC1:DATA?             ' Request latest CALC1 reading.

```

Buffer

The Model 622x has a buffer (data store) to store readings and related data elements for one to 65,536 buffer readings. Buffer readings are readings from the Model 2182/2182A that were processed by the Model 622x as delta readings (Delta, Pulse Delta, or Differential Conductance). Also stored are statistics for the readings. These include maximum, minimum, average mean, standard deviation, and peak-to-peak.

For **front panel operation**, the buffer is always active (enabled). Post-math delta readings are automatically stored in the buffer.

Remote programming provides more control of the buffer:

- The buffer can be disabled.
- When enabled, buffer feed can be pre-math delta readings or post-math delta readings.
- The timestamp can be set for the absolute format or the delta format.

NOTE For remote programming, only the buffer recall commands are documented in this section. See Section 6 of the Reference Manual for details on all buffer commands.

Buffer characteristics

Buffer size

The buffer size automatically sets to accommodate the number of delta readings to be performed. For example, if the test is configured to perform 1,000 delta measurements, the buffer size will be set to 1000.

If the delta test is configured to perform an infinite number of delta measurements, the buffer will be set to maximum size (65,536 readings). After the 65,536th reading, the delta test continues but readings stop being stored.

Buffer data elements

Data elements are stored along with each delta reading. The data elements for **front panel operation** are shown in [Figure 6-1](#). These include reading number, timestamp, reading units, and the current source output value.

For **remote programming**, the returned reading string for a buffer read command includes the reading and the data elements in the following order:

Reading with Units, Timestamp, Current Source, Average Voltage, Compliance State, and Reading Number.

Buffer statistics

The following statistics are available on the stored buffer readings:

- **MIN** and **MAX** provides the minimum and maximum readings stored in the buffer. It also indicates the buffer location of these readings.
- The **PK-PK (peak-to-peak)** value is the difference between the maximum and minimum readings stored in the buffer:

$$\text{PK-PK} = \text{MAX} - \text{MIN}$$

- **Mean** is the mean average of the buffer readings. Mean is calculated as follows:

$$y = \sum_{i=1}^n \frac{X_i}{n}$$

Where: X_i is a stored reading.
 n is the number of stored readings.

- The **STD DEV** value is the standard deviation of the buffered readings. Standard deviation is calculated as follows:

$$y = \sqrt{\frac{\sum_{i=1}^n (\text{Avg} - X_i)^2}{n - 1}}$$

Where: X_i is a stored reading.
 n is the number of stored readings.
 Avg is the mean of the buffer readings.

Buffer timestamp

Each buffer reading has a timestamp. The absolute timestamp is referenced to the first stored reading in the buffer, which is timestamped at 0.0s.

Storing readings

Unless it was disabled using remote operation, the buffer is always active (enabled), and post-math readings are automatically stored in the buffer.

Recall

Buffer readings – Press **RECALL** and use the edit keys shown in [Figure 6-1](#) to navigate through the buffer to view stored readings.

Buffer statistics – While in buffer RECALL, use the **EDIT/LOCAL** key (see [Figure 6-1](#)). Each press of this key displays the next statistic. After the last statistic is displayed (Std Dev), pressing **EDIT/LOCAL** will display the stored readings. When finished, press **EXIT** to return to the normal display.

Figure 6-1
Buffer recall

A) Front panel edit keys to display buffer readings:

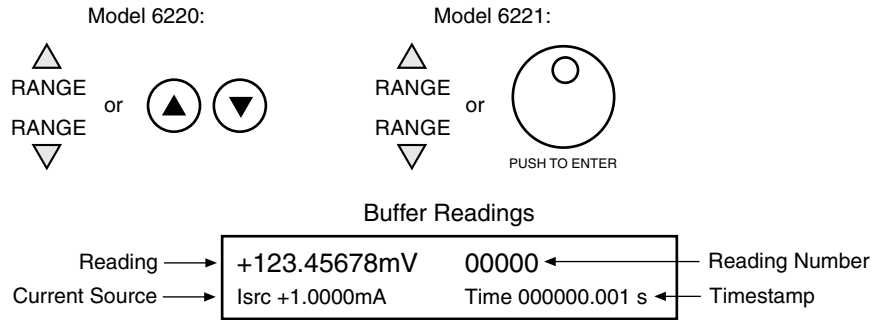

B) Use EDIT/LOCAL key to display buffer statistics:

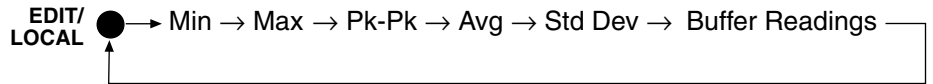

For **remote programming**, the commands to recall delta readings and statistics are listed in [Table 6-4](#).

Table 6-4
Buffer commands

Command	Description	Default
TRACe:DATA?	Request all readings in buffer.	
CALCulate2:FORMat <name>	Select buffer statistic: <name> = MEAN, SDEViation, MAXimum, MINimum, or PKPK	MEAN
CALCulate2:STATe 	Enable or disable calculation: = ON or OFF	OFF
CALCulate2:IMMediate	Perform the selected calculation on buffer readings.	
CALCulate2:DATA?	Read the result of the buffer statistic.	

Wave Functions (6221 Only)

Section 7 topics

Wave function overview, page 7-2

Setting waveform parameters, page 7-3

Editing parameters, page 7-3

Amplitude and offset editing, page 7-3

Amplitude and units, page 7-3

Ranging, page 7-3

Range options, page 7-3

Arbitrary waveform ranging, page 7-4

Frequency, page 7-4

Offset, page 7-4

Duty cycle, page 7-5

Phase marker, page 7-6

Duration, page 7-7

Externally triggered waveforms, page 7-7

Front panel wave function operation, page 7-8

Using the wave function menu, page 7-8

Generating a sine wave, page 7-10

Generating an arbitrary waveform, page 7-11

Remote wave function operation, page 7-12

Programming sine waves, page 7-13

Programming arbitrary waveforms, page 7-14

SCPI commands — wave functions, page 7-15

NOTE	The information in this section is an abbreviated version of the information in Section 7 of the Reference Manual. Refer to Section 7 of the Reference Manual for complete details and additional information that is not provided in this manual.
-------------	---

Wave function overview

Table 7-1 summarizes the basic characteristics of the four wave functions available in the Model 6221. More details on various aspects can be found in the following paragraphs.

Table 7-1

Wave function characteristics

Wave function	Characteristics
Sine wave	Frequency: 1mHz to 100kHz Amplitude: 1pA to 105mA peak Range: 2nA to 100mA Offset: 0 to ± 105 mA Phase marker: 0° to 360° Duration: 100ns to 999999.999s
Square wave	Frequency: 1mHz to 100kHz Amplitude: 1pA to 105mA peak Range: 2nA to 100mA Offset: 0 to ± 105 mA Duty cycle: 0 to 100% Phase marker: 0° to 360° Duration: 100ns to 999999.999s
Ramp wave	Frequency: 1mHz to 100kHz Amplitude: 1pA to 105mA peak Range: 2nA to 100mA Offset: 0 to ± 105 mA Duty cycle: 0 to 100% Phase marker: 0° to 360° Duration: 100ns to 999999.999s
Arbitrary wave	Frequency: 1mHz to 100kHz Amplitude: 1pA to 105mA peak Range: 2nA to 100mA Offset: 0 to ± 105 mA Number of points: 2 to 65,535 Phase marker: 0° to 360° Duration: 100ns to 999999.999s

Setting waveform parameters

NOTE User setups cannot be saved or recalled while Wave is armed or running. Attempting to do so will generate error +413 Not allowed with mode arm.

Editing parameters

The AMPL and FREQ keys also function as left arrow and right arrow keys, respectively, when editing a numeric value or scrolling through a menu.

Amplitude and offset editing

The Model 6221 Amplitude and Offset menus are coupled and follow special rules for editing. To change amplitude, press the AMPL key, use the arrow keys to select a digit, and use the knob to change the value. The range up and down arrows are used to change the amplitude range. Once you have selected an Amplitude range and entered the desired value, go into the Offset menu (CONFIG->WAVE->OFFSET) to set the offset value.

Amplitude and units

The amplitude setting range for all four waveform types is from 1pA to 105mA peak. The peak-to-peak value is double the amplitude setting. For example, a 1mA amplitude setting results in a 2mA peak-to-peak waveform.

The front panel allows setting wave amplitude in either RMS or peak units. The default is Peak, and the RMS selection will only apply for sine wave ($\text{RMS} = 0.70710678 \times \text{peak}$) or triangle wave ($\text{RMS} = 0.57735027 \times \text{peak}$) and will be ignored for other waveform types.

Ranging

Range options

There are two methods of ranging:

- **BEST FIXED** — This option will automatically select the range based on the amplitude and offset parameters set at the time the waveform is armed.
- **FIXED** — With this option, the waveform will be generated on the current range set at the time the wave is armed (after error checking is performed). If using this option, be sure that range is high enough for the selected amplitude and offset.

Arbitrary waveform ranging

The arbitrary waveform is described in normalized units from -1 to +1. See the following example:

Ranging: BEST

Amplitude: 10mA peak

Offset: 0mA

ARB values: range from +1 to -1

These settings will generate a waveform with a peak-to-peak value of 20mA on the 20mA range.

Frequency

The frequency setting range for sine, square, ramp, and arbitrary waveforms is from 1mHz to 100kHz. Note that the period is the reciprocal of the frequency: $1/f$. For example, a 1kHz waveform has a period of 1ms.

Offset

The offset setting allows you to add a DC offset value to a waveform. [Figure 7-1](#) shows an example of a 1mA offset added to a square wave with a 10mA peak (20mA peak-to-peak) amplitude.

Figure 7-1
Offset example

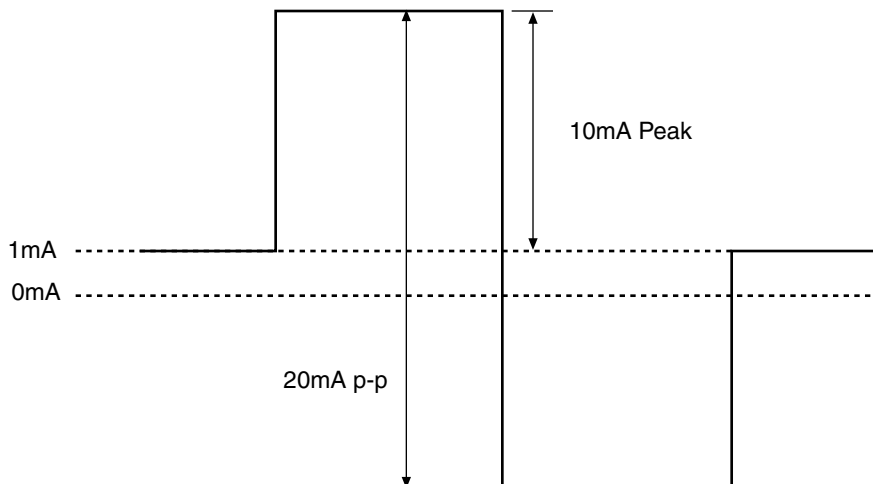

Duty cycle

For a square wave [Figure 7-2A](#), the duty cycle setting is the portion of the total cycle that the wave is high relative to the period of the waveform. For a ramp waveform [Figure 7-2B](#), the duty cycle corresponds to the fraction of the total wave cycle that is rising. A 50% duty cycle corresponds to a symmetric triangle wave. The left waveform in B has a 100% duty cycle, the center waveform has 0% duty cycle, and the right waveform has 50% duty cycle. A 0° marker setting for ramp waveforms corresponds to the minimum output at the start of ramp-up. For sine and square wave, a 0° marker setting for square and sine waves is the zero-crossing point.

Figure 7-2
Duty cycle

A. Square Wave Duty Cycle

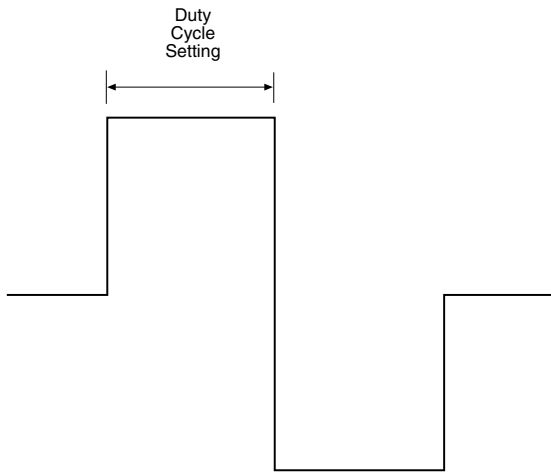

B. Ramp Wave Duty Cycle

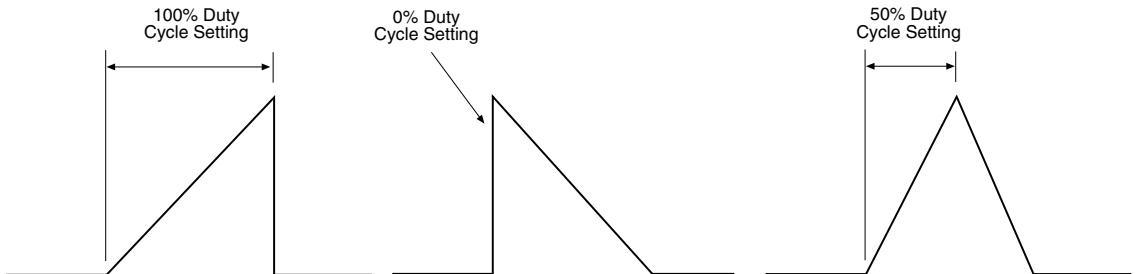

Phase marker

The phase marker (Figure 7-3) allows you to set a pulse marker that defines a specific point of a waveform over a range of 0 to 360°. The phase marker signal is a 1 μ s pulse that appears on the selected line of the external trigger connector (see information on the external trigger connector in Section 8 of the Model 622x Reference Manual for connector designations). You can also define which trigger output line is used for the phase marker pulse (default is line 3), but you cannot use the same line used for the external trigger output (default is 2) or the waveform external trigger input line (default is 0 or disabled). A 0° marker setting for ramp waveforms corresponds to the minimum output at the start of ramp-up. For sine and square wave, a 0° marker setting for square and sine waves is the zero-crossing point.

Figure 7-3
Phase marker

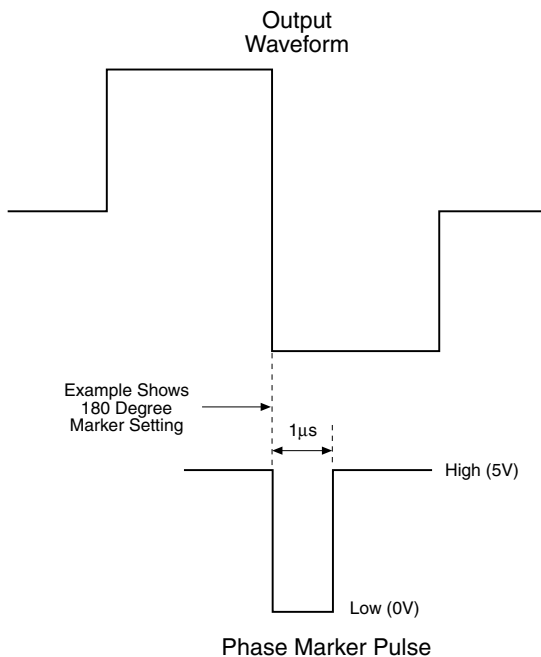

Duration

The duration setting defines how long the waveform is generated. You can set the duration in time over a range of 100ns to 999999.999s, in cycles from 0.001 to 99999999900 cycles (provided the equivalent time, cycles/frequency does not exceed the upper time duration limit), or choose a continuous waveform (INFinite setting). From the front panel, you can only specify a time duration from 0.001s to 999999.999s and a cycle duration as an integer number of cycles between 1 and 99999999900.

When a waveform is armed, the execution time is determined based on the explicitly programmed time duration or calculated from the specified cycles or duration settings. The time duration cannot be changed while a waveform is armed. If the frequency is changed while the waveform is armed, the existing execution time will remain fixed. The equivalent time duration will not be recalculated even if the duration is set to cycles. If the same number of cycles is desired at the new frequency, the wave function should be aborted and then re-armed to force the recalculation of waveform execution time.

Externally triggered waveforms

Model 6221 units with firmware revision A03 or later include a mode to trigger the arbitrary waveform generator using the instrument's trigger link lines. When this mode is enabled, the instrument waits for an external trigger pulse on a specified trigger link line and starts the configured waveform within 1 μ s of the falling edge of the trigger pulse.

This manual section summarizes front panel menu selections and remote commands to control this mode. For complete details on using externally triggering waveforms, see Section 7 of the Model 6220/6221 Reference Manual.

Front panel wave function operation

Using the wave function menu

To configure wave functions, press CONFIG then WAVE, then make your selections from [Table 7-2](#) below. See the detailed procedures for each wave function type that follow.

Table 7-2

Wave function configuration menu

Menu selection	Description
TYPE SINE SQUARE RAMP ARBx	Select waveform type: Select sine wave. Select square wave. Select ramp wave. Select user-defined arbitrary wave. ¹ Where: x = 0 to 4.
OFFS	Enter DC offset (0 to $\pm 105\text{mA}$).
AMPL-UNIT	Select amplitude units (PEAK or RMS). (Front panel only.)
DUTY-CYCLE	Enter duty cycle (0 to 100%).
PH-MKR STATE OUTPUT-POINT OUTPUT-LINE	Select phase marker and line: Turn phase marker ON or OFF. 0 to 360° Set trigger output line (OFF, #1 to #6).
DURATION INFINITE SET-TIME SET-CYCLES	Set duration of waveform: Continuous waveform. Set duration in time (0.001s to 999999.999s). Set duration in cycles (0.001 to 99999999900).
RANGING BEST-FIXED FIXED	Select ranging for selected wave function: Select best range based on wave amplitude. Stay on fixed range when waveform is armed.

1. Arbitrary waveforms can be defined only via remote. Location 0 is volatile RAM, while locations 1-4 are NVRAM and will be saved across power cycles.
2. Waveform triggering available in revision level A03 and later firmware. See Section 7 of the Model 6220/6221 Reference Manual for details on externally triggering waveforms.

Table 7-2 (cont.)

Wave function configuration menu

Menu selection	Description
MORE	Expand to show additional menu items:
TRIG-MODE MAN/BUS NONE TLNK-#1 #2 #3 #4 #5 #6	Configure low jitter external waveform triggering: ² Disable external trigger mode (default). Enables external trigger mode with no line selected. Enables external trigger on trigger link line 1. Enables external trigger on trigger link line 2. Enables external trigger on trigger link line 3. Enables external trigger on trigger link line 4. Enables external trigger on trigger link line 5. Enables external trigger on trigger link line 6.
RE-TRIG IGNORE-TRIG RESTART-IMMEDIATELY	Configure response to external retriggering: Ignore subsequent triggers while outputting a wave. Restart waveform immediately upon each trigger.
INACTIVE-VAL	Set output value before and after triggered waveforms.

1. Arbitrary waveforms can be defined only via remote. Location 0 is volatile RAM, while locations 1-4 are NVRAM and will be saved across power cycles.
2. Waveform triggering available in revision level A03 and later firmware. See Section 7 of the Model 6220/6221 Reference Manual for details on externally triggering waveforms.

Generating a sine wave

1. If you intend to use fixed ranging, manually set the range high enough to accommodate both the amplitude and offset setting.
2. **Configure the waveform as follows:**
 - a. Press CONFIG then WAVE to enter the wave function configuration menu.
 - b. Select TYPE, then press ENTER.
 - c. Select SINE, then press ENTER to choose a sine wave.
 - d. To add a DC offset, select OFFSET from the CONFIGURE WAVEFORM menu, then set the offset as desired.
 - e. To use the phase marker, select PHASE-MARKER, set the STATE to ON, use OUTPUT-POINT to set the phase setting, and OUTPUT-LINE to set the trigger line.
 - f. Again from the CONFIGURE WAVEFORM menu, choose RANGING, press ENTER, then select BEST-FIXED or FIXED as desired.
 - g. From the CONFIGURE WAVEFORM menu, select DURATION, then set the desired waveform duration.
 - h. From the CONFIGURE WAVEFORM menu, select AMPL-UNIT, then set the desired amplitude units (PEAK or RMS).
 - i. Press EXIT to return to normal display.
3. **Set frequency and amplitude:**
 - a. Press the FREQ key, then set the frequency to the desired value.
 - b. Press the AMPL key, then set the amplitude as required.
4. **Generate waveform:**
 - a. Press the WAVE key to arm the wave function.
 - b. Press TRIG to turn on the output and start generating the waveform.
 - c. The output will turn off after the currently set duration period has expired. If the duration is set to infinite, press the EXIT key to stop generating the waveform and turn the output off.

Generating an arbitrary waveform

NOTE	Arbitrary waveforms cannot be defined from the front panel, but they can be generated once they are defined by using the procedure below.
-------------	--

1. If you are using the fixed range setting, manually set the range to a high enough setting to accommodate the expected amplitude and offset settings.
2. **Configure the waveform as follows:**
 - a. Press CONFIG then WAVE to enter the wave function configuration menu.
 - b. Select TYPE, then press ENTER.
 - c. Select ARBx, where x is the arbitrary waveform to use (0-4).
 - d. To add a DC offset, select OFFSET from the CONFIGURE WAVEFORM menu, then set the offset as desired.
 - e. To use the phase marker, select PHASE-MARKER, set the STATE to ON, use OUTPUT-POINT to set the phase setting, and OUTPUT-LINE to set the trigger line.
 - f. Again from the CONFIGURE WAVEFORM menu, choose RANGING, press ENTER, then select BEST-FIXED or FIXED as desired.
 - g. From the CONFIGURE WAVEFORM menu, select DURATION, then set the desired waveform duration.
 - h. Press EXIT to return to normal display.
3. **Set frequency and amplitude:**
 - a. Press the FREQ key, then set the frequency to the desired value.
 - b. Press the AMPL key, then set the amplitude as required.
4. **Generate waveform:**
 - a. Press the WAVE key to arm the wave function.
 - b. Press TRIG to turn on the output and start generating the waveform.
 - c. The output will turn off after the currently set duration period has expired. If the duration is set to infinite, press the EXIT key to stop generating the waveform and turn the output off.

Remote wave function operation

Procedures for programming and generating waveforms for sine and arbitrary waveform types are given on the following pages. Each of these procedures includes commands for a typical wave function example. [Table 7-3](#) summarizes parameters for each of these examples. See [“SCPI commands — wave functions,” page 7-15](#) for a listing of wave function commands.

Table 7-3

Waveform example parameters

Waveform	Parameters for waveform examples
Sine wave (page 7-13)	Frequency: 1kHz Amplitude: 10mA Offset: 1mA Phase marker: off Duration: 5s
Arbitrary wave (page 7-14)	Arbitrary points: -0.5, -0.25, 0, 0.3, 0.4 Range: best fixed Frequency: 100kHz Amplitude: 25mA Offset: 0 Phase marker: Off Duration: 20s

Programming sine waves

1. **Restore defaults with this command:**

```
*RST
```

2. **Configure the waveform.**

Examples – The following commands configure a 1kHz sine wave with an amplitude of 10mA, 1mA offset, and phase marker off:

```
SOUR:WAVE:FUNC SIN           ' Select sine wave.
SOUR:WAVE:FREQ 1e3           ' Set frequency to 1kHz.
SOUR:WAVE:AMPL 1e-2          ' Set amplitude to 10mA.
SOUR:WAVE:OFFS 1e-3          ' Set offset to 1mA.
SOUR:WAVE:PMAR:STAT OFF     ' Turn off phase marker.
SOUR:WAVE:DUR:TIME 5        ' 5 second duration.
SOUR:WAVE:RANG BEST         ' Select best fixed source range.
```

3. **Arm and trigger the waveform, turn on output:**

```
SOUR:WAVE:ARM                ' Arm waveform.
SOUR:WAVE:INIT               ' Turn on output, trigger waveform.
```

4. **To stop generating the waveform and turn the source output off before the duration elapses, send this command:**

```
SOUR:WAVE:ABOR              ' Stop generating waveform.
```

Programming arbitrary waveforms

1. **Restore defaults with this command:**

```
*RST
```

2. **Configure the waveform.**

Examples – The following commands configure a 100kHz arbitrary wave with an amplitude of 25mA, 0mA offset, phase marker off, and 20 second duration:

```
SOUR:WAVE:ARB:DATA -0.5, -0.25, ' Define arbitrary data points in
0, 0.3, 0.4 ' location 0.
SOUR:WAVE:ARB:COPY 1 ' Copy points to location 1.
SOUR:WAVE:FUNC ARB1 ' Select arb wave, location 1.
SOUR:WAVE:FREQ 1e5 ' Set frequency to 100kHz.
SOUR:WAVE:AMPL 25e-3 ' Set amplitude to 25mA.
SOUR:WAVE:OFFS 0 ' Set offset to 0.
SOUR:WAVE:PMAR:STAT OFF ' Turn off phase marker.
SOUR:WAVE:DUR:TIME 20 ' 20 second duration.
SOUR:WAVE:RANG BEST ' Select best fixed source range.
```

3. **Arm and trigger the waveform, turn on output:**

```
SOUR:WAVE:ARM ' Arm waveform.
SOUR:WAVE:INIT ' Turn on output, trigger waveform.
```

4. **To stop generating the waveform and turn the source output off before the duration elapses, send this command:**

```
SOUR:WAVE:ABOR ' Stop generating waveform.
```

SCPI commands — wave functions

Commands for wave functions are listed in [Table 7-4](#).

Table 7-4

Waveform function commands

Command	Description	Default
SOURCE[1]:WAVE:FUNCTion <name>	Selects wave function. <name> = SINusoid, SQUare, RAMP, or ARBITraryX (0-4)	SIN
SOURCE[1]:WAVE:DCYCLe <NRf>	Sets duty cycle. <NRf> = 0 to 100 (%)	50
SOURCE[1]:WAVE:AMPLitude <NRf>	Sets amplitude. <NRf> = 2e-12 to 0.105 (A peak)	1e-3
SOURCE[1]:WAVE:FREQuency <NRf>	Sets frequency. <NRf> = 0 to 1e5 (Hz)	1e3
SOURCE[1]:WAVE:OFFset <NRf>	Sets offset. <NRf> = -0.105 to 0.105 (A)	0
SOURCE[1]:WAVE:RANGing <name>	Selects ranging mode. <name> = BEST or FIXed	BEST
SOURCE[1]:WAVE:PMARk <NRf>	Sets marker phase. <NRf> = 0 to 360 (deg.)	180
SOURCE[1]:WAVE:PMARk:STATe 	Enables/disables phase marker. = ON or OFF	OFF
SOURCE[1]:WAVE:PMARk:OLINe <NRf>	Sets phase marker trigger line. <NRf> = 1 to 6	3
SOURCE[1]:WAVE:ARBITrary:DATA <NRf> [,<NRf>, ... <NRf>]	Defines arbitrary data points. <NRf> = -1 to +1 (100 points max.)	
SOURCE[1]:WAVE:ARBITrary:APPend <NRf> [,<NRf>, ... <NRf>]	Appends arbitrary data points. <NRf> = -1 to +1 (100 points max. per instance of command)	
SOURCE[1]:WAVE:ARBITrary:COPIY <NRf>	Copies arbitrary points to NVRAM. <NRf> = 1 to 4	
SOURCE[1]:WAVE:ARBITrary:POINts?	Queries # of arbitrary data points.	

Table 7-4 (cont.)

Waveform function commands

Command	Description	Default
SOURCE [1] : WAVE : ARM	Arms 6221 for waveform output.	
SOURCE [1] : WAVE : INITiate	Starts waveform output.	
SOURCE [1] : WAVE : ABORT	Aborts waveform output.	
SOURCE [1] : WAVE : DURation : TIME <NRf>	Sets waveform time duration. <NRf> = 100e-9 to 999999.999 (s) or INFINITY.	INFINITY
SOURCE [1] : WAVE : DURation : CYCLes <NRf>	Sets waveform duration in cycles. <NRf> = 0.001 to 99999999900 or INFINITY.	INFINITY
SOURCE [1] : WAVE : EXTRig [: ENABLE] 	Enables/disables mode to externally trigger the waveform generator. * = ON or OFF	OFF
SOURCE [1] : WAVE : EXTRig : ILINE <NRf>	Specify trigger link input trigger line. <NRf> = 0 (none) or 1 to 6	0
SOURCE [1] : WAVE : EXTRig : IGNore 	Sets whether or not to restart waveform upon retriggering. = ON or OFF	OFF
SOURCE [1] : WAVE : EXTRig : IVALue <NRf>	Sets inactive value to output before/ after waveform. <NRf> = -1 to +1	0.00

* Waveform triggering available with firmware revision level A03 and later. See Section 7 of the Model 6220/6221 Reference Manual for details.

A Specifications

6220 Programmable Current Source

SOURCE SPECIFICATIONS

Range (+5% over range)	Accuracy (1 Year) 23°C±5°C ±(%rdg. + amps)	Programming Resolution	Temperature Coefficient/°C 0°-18°C & 28°-50°C	Typical Noise (peak-peak) /RMS ^{3,4,5} 0.1Hz-10Hz	Settling Time ^{1,2} (1% of final value)
2nA	0.4% + 2pA	100fA	0.02% + 200fA	400/80fA	100µs
20nA	0.3% + 10pA	1pA	0.02% + 200fA	4/0.8pA	100µs
200nA	0.3% + 100pA	10pA	0.02% + 2pA	20/4pA	100µs
2µA	0.1% + 1nA	100pA	0.01% + 20pA	200/40pA	100µs
20µA	0.05% + 10nA	1nA	0.005% + 200pA	2/0.4nA	100µs
200µA	0.05% + 100nA	10nA	0.005% + 2nA	20/4nA	100µs
2mA	0.05% + 1µA	100nA	0.005% + 20nA	200/40nA	100µs
20mA	0.05% + 10µA	1µA	0.005% + 200nA	2/0.4µA	100µs
100mA	0.1% + 50µA	10µA	0.01% + 2µA	10/2µA	100µs

ADDITIONAL SOURCE SPECIFICATIONS

OUTPUT RESISTANCE: $>10^{14}\Omega$. (2nA/20nA range)

OUTPUT CAPACITANCE: $<10\text{pF}$, $<100\text{pF}$ Filter ON. (2nA/20nA range)

LOAD IMPEDANCE: Stable into 100µH typical.

CURRENT REGULATION: Line: $<0.01\%$ of range.

Load: $<0.01\%$ of range.

VOLTAGE LIMIT (Compliance): Bipolar voltage limit set with single value. 0.1V to 105V in 0.01V programmable steps.

Accuracy for 0.1V to 20V: 0.1% + 20mV, accuracy for 20V to 105V: 0.1% + 100mV

MAX. OUTPUT POWER: 11W, four quadrant source or sink operation.

GUARD OUTPUT:

Maximum Load Capacitance: 10nF.

Maximum Load Current: 1mA for rated accuracy.

Accuracy: $\pm 1\text{mV}$ for output currents $<2\text{mA}$. (excluding output lead voltage drop).

PROGRAM MEMORY: (offers point-by-point control and triggering, e.g. Sweeps)

Number of Locations: 64K.

EXTERNAL TRIGGER: TTL-compatible EXTERNAL TRIGGER INPUT and OUTPUT.

Max Trigger Rate: 1000/s.

6220 – 2182 MEASUREMENT FUNCTIONS

DUT RESISTANCE: Up to 1GΩ (1 nSiemen).

DELTA MODE RESISTANCE MEASUREMENTS and DIFFERENTIAL CONDUCTANCE: Controls Keithley Model 2182A Nanovoltmeter at up to 24Hz reversal rate (2182 at up to 12Hz).

Source Notes

- 1 Settling times are specified into a resistive load, with a maximum resistance equal to $2\text{V} / I_{\text{fullscale}}$ of range. See manual for other load conditions.
- 2 Settling times to 0.1% of final value are typically $<2\text{x}$ of 1% settling times.
- 3 Noise current into $<100\Omega$.
- 4 RMS Noise 10Hz-20MHz (2nA – 20mA Range) Less than 1mVrms, 5mVp-p (into 50Ω load).
- 5 Typical values are non-warranted, apply at 23°C, represent the 50th percentile, and are provided solely as useful information.

6220 Programmable Current Source

GENERAL SPECIFICATIONS

COMMON MODE VOLTAGE: 250V rms, DC to 60Hz.

COMMON MODE ISOLATION: $>10^9\Omega$, $<2\text{nF}$.

SOURCE OUTPUT MODES: Fixed DC level, Memory List.

REMOTE INTERFACE:

IEEE-488 and RS-232C.

SCPI (Standard Commands for Programmable Instruments)

DDC (command language compatible with Keithley Model 220)

PASSWORD PROTECTION: 11 characters.

DIGITAL INTERFACE:

Handler Interface: Start of test, end of test, 3 category bits, +5V@300mA supply.

Digital I/O: 1 trigger input, 4 TTL/Relay Drive outputs (33V@500mA, diode clamped).

OUTPUT CONNECTIONS:

- Teflon insulated 3-lug triax connector for output.
- Banana Safety Jack for GUARD, OUTPUT LO
- Screw Terminal for CHASSIS
- DB-9 connector for EXTERNAL TRIGGER INPUT, OUTPUT, and DIGITAL I/O
- Two position Screw Terminal for INTERLOCK

INTERLOCK: Maximum 10Ω external circuit impedance.

POWER SUPPLY: 100V to 240V rms, 50-60Hz.

POWER CONSUMPTION: 120VA.

WARRANTY: 1 Year.

ENVIRONMENT:

For Indoor Use Only: Maximum 2000m above Sea Level.

Operating: 0° - 50°C , 70%R.H. up to 35°C . Derate 3% R.H./ $^{\circ}\text{C}$, 35° - 50°C .

Storage: -25°C to 65°C , guaranteed by design.

EMC: Conforms to European Union Directive 89/336/EEC, EN 61326-1.

SAFETY: Conforms to European Union Directive 73/23/EEC, EN61010-1.

VIBRATION: MIL-PRF-28800F Class 3, Random.

WARMUP: 1 hour to rated accuracies.

Passive Cooling: No fan.

DIMENSIONS:

Rack Mounting: 89mm high x 213mm wide x 370mm deep (3.5 in. x 8.375 in. x 14.563 in.).

Bench Configuration (with handle and feet): 104mm high x 238mm wide x 370mm deep (4.125 in. x 9.375 in. x 14.563 in.).

SHIPPING WEIGHT: 4.75kg (10 lbs).

ACCESSORIES SUPPLIED: Model 237-ALG-2 Triaxial Test Lead (6.6ft), Trigger Link cable, RS-232 (Null Modem) cable, Interlock terminal block, User's Manual, CD Manual, LabVIEW Drivers.

6221 AC and DC Current Source

SOURCE SPECIFICATIONS

Range (+5% over range)	Accuracy (1 Year) 23°C±5°C ±(%rdg. + amps)	Programming Resolution	Temperature Coefficient/°C 0°-18°C & 28°- 50°C	Typical Noise (peak-peak) /RMS ^{3,5} 0.1Hz-10Hz	Typical Noise (peak-peak) /RMS ^{3,4,5} 10Hz-(BW)	Output Response Bandwidth (BW) into Short	Settling Time ^{1,2} (1% of final value)	
							Output Resp. Fast (Typical ⁵)	Output Resp. Slow (Max)
2nA	0.4% + 2pA	100fA	0.02% + 200fA	400/80fA	250/50pA	10kHz	90µs	100µs
20nA	0.3% + 10pA	1pA	0.02% + 200fA	4/0.8pA	250/50pA	10kHz	90µs	100µs
200nA	0.3% + 100pA	10pA	0.02% + 2pA	20/4pA	2.5/0.5nA	100kHz	30µs	100µs
2µA	0.1% + 1nA	100pA	0.01% + 20pA	200/40pA	25/5.0nA	1MHz	4µs	100µs
20µA	0.05% + 10nA	1nA	0.005% + 200pA	2/0.4nA	500/100nA	1MHz	2µs	100µs
200µA	0.05% + 100nA	10nA	0.005% + 2nA	20/4nA	1.0/0.2µA	1MHz	2µs	100µs
2mA	0.05% + 1µA	100nA	0.005% + 20nA	200/40nA	5.0/1µA	1MHz	2µs	100µs
20mA	0.05% + 10µA	1µA	0.005% + 200nA	2/0.4µA	20/4.0µA	1MHz	2µs	100µs
100mA	0.1% + 50µA	10µA	0.01% + 2µA	10/2µA	100/20µA	1MHz	3µs	100µs

ADDITIONAL SOURCE SPECIFICATIONS

OUTPUT RESISTANCE: >10¹⁴Ω. (2nA/20nA range)

OUTPUT CAPACITANCE: <10pF, <100pF Filter ON. (2nA/20nA range)

LOAD IMPEDANCE: Stable into 10µH typical, 100µH with Output Response SLOW.

CURRENT REGULATION: Line: <0.01% of range. **Load:** <0.01% of range.

VOLTAGE LIMIT (Compliance): Bipolar voltage limit set with single value. 0.1V to 105V in 0.01V programmable steps.

Accuracy for 0.1V to 20V: 0.1% +20mV, accuracy for 20V to 105V: 0.1% + 100mV

MAX. OUTPUT POWER: 11W, four quadrant source or sink operation.

GUARD OUTPUT:

Maximum Load Capacitance: 10nF.

Maximum Load Current: 1mA for rated accuracy.

Accuracy: ±1mV for output currents <2mA (excluding output lead voltage drop).

PROGRAM MEMORY: (offers point-by-point control and triggering, e.g. Sweeps)

Number of Locations: 64K.

EXTERNAL TRIGGER: TTL-compatible EXTERNAL TRIGGER INPUT and OUTPUT.

Max Trigger Rate: 1000/s.

Source Notes

1. Settling times are specified into a resistive load, with a maximum resistance equal to 2V / I_{fullscale} of range. See manual for other load conditions.
2. Settling times to 0.1% of final value are typically <2x of 1% settling times.
3. Noise current into <100Ω.
4. RMS Noise 10Hz-20MHz (2nA – 20mA Range) Less than 1mVrms, 5mVp-p (into 50Ω load).
5. Typical values are non-warranted, apply at 23°C, represent the 50th percentile, and are provided solely as useful information.

6221 AC and DC Current Source

ARBITRARY FUNCTION GENERATOR

WAVEFORMS: Sine, Square, Ramp, and 4 User Defined Arbitrary Waveforms.

FREQUENCY ACCURACY⁴: ± 100 ppm (1 Year)

AMPLITUDE: 2pA to 210mA peak-peak into loads up to $10^{12}\Omega$.

AMPLITUDE ACCURACY (<10kHz):²

Magnitude: 1% rdg + 0.2% rng

Offset: 0.2% rdg + 0.2% rng

SINE WAVE CHARACTERISTICS:

Frequency Range: 1mHz to 100kHz.²

Amplitude Flatness: Less than 1dB up to 100kHz.⁴

SQUARE WAVE CHARACTERISTICS:

Frequency Range: 1mHz to 100kHz.²

Overshoot: $<2.5\%$ ⁴

Variable Duty Cycle:^{1,3} Settable to 1 μ s min. pulse duration, 0.01% programming resolution.

Jitter (RMS): 100ns + 0.1% of period.⁴

RAMP WAVE CHARACTERISTICS:

Frequency Range: 1mHz to 100kHz.²

Linearity: $<0.1\%$ of peak output up to 10kHz.⁴

ARBITRARY WAVE CHARACTERISTICS:

Frequency Range: 1mHz to 100kHz.²

Waveform Length: 2 to 64K points.

Amplitude Resolution: 16 bits (including sign).⁵

Sample Rate: 10 MSPS.⁵

Jitter (RMS): 100ns + 0.1% of period.⁴

Maximum User Waveforms: 4.

PROGRAMMING TIME (Typical):⁶

Waveform/Amplitude/Frequency Change: 1ms

ARB Transfer Times:

(External transfer time over Bus)

	16K	64K
LAN	0.750s	3.000s
GPIB	1.250s	5.000s

(Internal transfer time of preloaded Arb locations 1-4)

Arb 1 0.001s 0.001s

Arb 2-4 0.500s 2.000s

6221 – 2182 MEASUREMENT FUNCTIONS

DUT RESISTANCE: Up to 1G Ω (1 nSiemen).

(100M Ω limit for pulse mode)

DELTA MODE RESISTANCE MEASUREMENTS and

DIFFERENTIAL CONDUCTANCE: Controls Keithley Model

2182A Nanovoltmeter at up to 24Hz reversal rate (2182 at up to 12Hz).

PULSE MEASUREMENTS:

Pulse widths 50 μ s to 12ms, 1pA to 100mA.

Repetition interval 83.3ms to 5s.

Waveform Notes:

1. Minimum realizable duty cycle is limited by current range response and load impedance.
2. Amplitude accuracy is applicable for 100mA through 2 μ A ranges (Fast Mode) into a maximum resistive load of $2V/I_{fullscale\ of\ range}$. Amplitude attenuation will occur at higher frequencies dependent upon current range and load impedance.
3. For frequencies less than 1 Hz, duty cycle not tested, guaranteed by design.
4. These Specifications are only valid for the 20mA range and a 50 Ω load.
5. These characteristics for informational purposes only.
6. Typical values are non-warranted, apply at 23 $^{\circ}$ C, represent the 50th percentile, and are provided solely as useful information.

GENERAL SPECIFICATIONS

COMMON MODE VOLTAGE: 250Vrms, DC to 60Hz.

COMMON MODE ISOLATION: $>10^9\Omega$, $<2nF$.

SOURCE OUTPUT MODES: Fixed DC level, Memory List, Arbitrary Waveform Function.

REMOTE INTERFACE

Ethernet: RJ-45 connector, TCP/IP (Auto sensed 10bT or 100bTx), IEEE-488, and RS-232C.

SCPI (Standard Commands for Programmable Instruments) DDC (command language compatible with Keithley Model 220)

IP CONFIGURATION: Static or DHCP.

PASSWORD PROTECTION: 11 characters.

DIGITAL INTERFACE:

Handler Interface: Start of test, end of test, 3 category bits, +5V@300mA supply.

Digital I/O: 1 trigger input, 4 TTL/Relay Drive outputs (33V@500mA, diode clamped).

OUTPUT CONNECTIONS:

- Teflon insulated 3-lug triax connector for output.
- Banana Safety Jack for GUARD, OUTPUT LO
- Screw Terminal for CHASSIS
- DB-9 connector for EXTERNAL TRIGGER INPUT, OUTPUT, and DIGITAL I/O
- Two position Screw Terminal for INTERLOCK

INTERLOCK: Maximum 10 Ω external circuit impedance.

POWER SUPPLY: 100V to 240V rms, 50-60Hz.

POWER CONSUMPTION: 120VA.

WARRANTY: 1 Year.

ENVIRONMENT:

For Indoor Use Only: Maximum 2000m above Sea Level.

Operating: 0 $^{\circ}$ -50 $^{\circ}$ C, 70%R.H. up to 35 $^{\circ}$ C. Derate 3% R.H./ $^{\circ}$ C, 35 $^{\circ}$ -50 $^{\circ}$ C.

Storage: -25 $^{\circ}$ C to 65 $^{\circ}$ C, guaranteed by design.

EMC: Conforms to European Union Directive 89/336/EEC, EN 61326-1.

SAFETY: Conforms to European Union Directive 73/23/EEC, EN61010-1.

VIBRATION: MIL-PRF-28800F Class 3, Random.

WARMUP: 1 hour to rated accuracies.

Passive Cooling: No fan.

DIMENSIONS:

Rack Mounting: 89mm high x 213mm wide x 370mm deep (3.5 in. x 8.375 in. x 14.563 in.).

Bench Configuration (with handle and feet): 104mm high x 238mm wide x 370mm deep (4.125 in. x 9.375 in. x 14.563 in.).

SHIPPING WEIGHT: 4.75kg (10 lbs).

ACCESSORIES SUPPLIED: Model 237-ALG-2 Triaxial Test Lead (6.6ft), Trigger Link cable, RS-232 (Null Modem) cable, Interlock terminal block, User's Manual, CD Manual, LabVIEW Drivers.

B

SCPI Tables (Abridged)

Appendix B tables

[Calculate command summary](#), page B-2

[Display command summary](#), page B-2

[Format command summary](#), page B-3

[Output command summary](#), page B-3

[Sense command summary](#), page B-3

[Source command summary](#), page B-4

[Status command summary](#), page B-7

[System command summary](#), page B-8

[Trace command summary](#), page B-9

[Trigger command summary](#), page B-10

[Units command summary](#), page B-10

The SCPI tables in this section are structured as follows:

- Only the shortform version of the command words and parameters are used.
- Most optional commands, which are denoted by brackets ([]), are not included.
- Most of the query commands are not included.

The unabridged SCPI table listings are provided in Section 14 of the Reference Manual.

Table B-1

Calculate command summary

Command	Description	Default
CALC	CALC commands (math calculations):	
:FORM <name>	Select math format: NONE, MXB (mX+b), or REC (m/X+b)	MXB
:KMAT	Configure math calculations:	
:MMF <NRf>	Set "m" for mX+b and m/X+b: -9.99999e20 to 9.99999e20	1.0
:MBF <NRf>	Set "b" for mX+b and m/X+b calculation: -9.99999e20 to 9.99999e20	0.0
:STAT 	Enable or disable CALC calculation.	OFF
:DATA?	Read calculation:	
:FRES?	Same as CALC:DATA? except reading can only be returned once.	
CALC2	CALC2 commands (buffer statistics):	
:FORM <name>	Select buffer statistic: MEAN, SDEV, MAX, MIN, or PKPK	MEAN
:STAT 	Enable or disable calculation.	OFF
:IMM	Perform the selected buffer calculation on buffer contents.	
:DATA?	Read the results of the buffer statistic.	
CALC3	CALC3 commands (limit testing):	
:LIM 	Stage 1 limit test:	
:SOUR2 <NRf>	Set limit test fail pattern: 0 to 15	15
:FAIL?	Query limit test pass/fail: 0 = pass, 1 = fail	
:FORC	Output force commands:	OFF
:STAT 	Enable or disable I/O pattern force state.	
:PATT <NRf>	Set I/O pattern: 0 to 15	15

Table B-2

Display command summary

Command	Description	Default
DISP	Display control commands:	(Note)
:ENAB 	Enables or disables front panel display and controls.	
:TEXT <a>	Define ASCII top message "a" (up to 20 characters).	
:STAT 	Enable or disable top line text message.	
:TEXT?	Read text message	
:ATTR?	Query attributes of top message characters: blinking (1) or not blinking (0).	
:WIND2	Bottom line display characters:	
:TEXT <a>	Define ASCII bottom message "a" (up to 32 characters).	
:STAT 	Enable or disable text message.	
:TEXT?	Read text message	
:ATTR?	Query attributes of message characters: blinking (1) or not blinking (0).	

Note: *RST and SYST:PRES have no effect on the display commands.

Table B-3

Format command summary

Command	Description	Default
FORM	Reading format commands:	
[:DATA] <type>	Specify data format: ASC, SRE, or DRE	ASC
:ELEM <item list>	Specify data elements: READ, TST, UNIT, RNUM, SOUR, COMP, AVOL (or ALL or DEF)	READ, TST
:BORD <name>	Specify byte order: NORM or SWAP.	(Note)
:SREG <name>	Select format for reading status registers: ASC, HEX, OCT or BIN.	ASC

Note: *RST default is NORM. SYST:PRES default is SWAP.

Table B-4

Output command summary

Command	Description	Default
OUTPut	Source output control:	
[:STAT]?	Turn output on or off (standby).	OFF
:LTE 	Connect output low to earth ground (ON) or float output low (OFF).	OFF
:ISH <name>	Connect triax inner shield to OLOW (output low) or cable GUAR.	OLOW
:RESP <name>	Set the output response for 6221: FAST or SLOW.	FAST
:INT	Interlock:	
:TRIP?	Returns a "0" if interlock is tripped (open) or a "1" if interlock is closed (output enabled).	

Table B-5

Sense command summary

Command	Description	Default
SENS	Commands for readings from 2182/2182A:	
:DATA?	Return the latest pre-math delta reading.	
:FRES?	Same as :DATA? except the reading can only be returned once.	
:AVER	Averaging filter:	
:TCON <name>	Select filter control: MOV or REP	MOV
:WIND <NRf>	Set filter window as % of range: 0 to 10	0.00
:COUN <NRf>	Specify filter count (size): 2 to 300	10
[:STAT] 	Enable or disable averaging filter.	OFF

Table B-6

Source command summary

Command	Description	Default
SOUR	Current source output commands:	
:CLE	Clearing the current source:	
[:IMM]	Set output to zero and then turn the output off.	
:CURR	Current source:	
[:AMPL] <n>	Set current source output (amps): -105e-3 to 105e-3	0.0
:RANG <n>	Select a fixed source range: -105e-3 to 105e-3	100e-3
:AUTO 	Enable or disable source auto range.	OFF
:COMP <NRf>	Set voltage compliance (volts): 0.1 to 105	10
:FILT 	Enable or disable analog filter.	
:STAR <n>	Set start current (amps): -105e-3 to 105e-3	0
:STOP <n>	Set stop current (amps): -105e-3 to 105e-3	100e-3
:STEP <n>	Set step current (amps): 1e-13 to 105e-3	1e-2
:CENT <n>	Set center current (amps): -105e-3 to 105e-3	0
:SPAN <n>	Set span current (amps): 2e-13 to 210e-3	100e-3
:DEL <n>	Set source delay (seconds): 1e-3 to 999999.999	1
:SWE	Source sweep operation:	
:SPAC <name>	Select sweep type: LIN, LOG or LIST	LIN
:POIN <n>	Set sweep points: 1 to 65535	11
:RANG <name>	Select sweep ranging: AUTO, BEST or FIX	BEST
:COUN <NRf>	Set sweep count: 1 to 9999 or INFINITY	1
:CAB 	Enable to abort sweep on compliance: ON or OFF	OFF
:ARM	Arm the sweep.	
:ABOR	Abort sweep or delta test immediately.	
:LIST	Custom sweep operation:	
:CURR <NRf> [,<NRf>, ...<NRf>]	Define list of currents (amps): -105e-3 to 105e-3	
:APP <NRf> [,<NRf>, ...<NRf>]	Add current points to existing list: -105e-3 to 105e-3	
:POIN?	Query number of current list points.	
:DEL <NRf> [,<NRf>, ...<NRf>]	Define list of delay values (secs): 1e-3 to 999999.999	1
:APP <NRf> [,<NRf>, ...<NRf>]	Add delay values to existing list.	

Table B-6 (cont.)

Source command summary

Command	Description	Default
:COMPLIance <NRf> [,<NRf>, ...<NRf>]	Define list of compliance values (volts): 1e-3 to 105	
:APP <NRf> [,<NRf>, ...<NRf>]	Add compliance values to existing list: 1e-3 to 105	
:DELta	Delta operation:	
:NVPR?	Query connection to 2182/2182A: 1 = yes, 0 = no	
:HIGH <NRf>	Set high source value (amps): 0 to 105e-3	1e3
:LOW <NRf>	Set low source value (amps): 0 to -105e-3	-1e3
:DEL <NRf>	Set Delta delay (seconds): 1e-3 to 9999.999	2e-3
:COUN <NRf>	Set number of cycles to run: 1 to 65536 or INFINITY.	INF
:CAB 	Enable to abort test on compliance: ON or OFF	OFF
:CSW 	Enable cold switching mode: ON or OFF.	OFF
:ARM	Arm Delta.	
:PDEL	Pulse Delta operation:	
:NVPR?	Query connection to 2182A: 1 = yes, 0 = no	
:HIGH <NRf>	Set high pulse value (amps): -105e-3 to 105e-3	1e3
:LOW <NRf>	Set low pulse value (amps): -105e-3 to 105e-3	0
:WIDT <NRf>	Set pulse width (seconds): 50e-6 to 12e-3	110e-6
:SDEL <NRf>	Set source delay (seconds): 16e-6 to 11.966e-3	16e-6
:COUN <NRf>	Set number of readings to perform: 1 to 65636 or INF	INF
:RANG <NRf>	Select fixed pulse source range: BEST or FIX	BEST
:INT <NRf>	Set interval (in PLCs) for each pulse cycle: 5 to 999999	5
:SWE 	Enable or disable Sweep output mode.	OFF
:LME <NRf>	Set number of low measurement per cycle: 1 or 2	2
:ARM	Arm Pulse Delta.	
:DCON	Differential Conductance operation:	
:NVPR?	Query connection to 2182/2182A: 1 = yes, 0 = no	
:STAR <NRf>	Set start value (amps): -105e-3 to 105e-3.	-10e-6
:STEP <NRf>	Set step size (amps): 0 to 105e-3.	1e-6
:STOP <NRf>	Set stop value (amps): -105e-3 to 105e-3.	+10e-6
:DELT <NRf>	Set delta value (amps): 0 to 105e-3.	1e-6
:DEL <NRf>	Set delay (seconds): 1e-3 to 9999.999.	2e-3
:CAB 	Enable to abort test on compliance: ON or OFF	OFF
:ARM	Arm Differential Conductance.	

Table B-6 (cont.)

Source command summary

Command	Description	Default
:WAVE	Wave function operation:	
:FUNC <name>	Select wave function: SIN, SQU, RAMP or ARBX (X = 0 to 4).	SIN
:DCYC <NRf>	Set duty cycle (in %): 0 to 100	50
:AMPL <NRf>	Set amplitude (amps peak): 2e-12 to 105e-3.	1e-3
:FREQ <NRf>	Set frequency (Hz): 1e-3 to 1e5	1e3
:OFFS <NRf>	Set offset (amps): -105e-3 to 105e-3	0
:PMAR	Phase marker:	
[:LEV] <NRf>	Set marker phase (in degrees): 0 to 360	180
:OLIN <NRf>	Set phase marker trigger line: 1 to 6	3
:STAT 	Enable or disable phase marker.	OFF
:ARB	Arbitrary waveforms:	
:DATA <NRf> [,<NRf>, ...<NRf>]	Define arbitrary data points: -1 to +1 (100 points maximum).	
:DATA?	Query the points in the arbitrary waveform.	
:APP <NRf> [,<NRf>, ...<NRf>]	Append arbitrary data points: -1 to +1 (100 points max. per instance of command).	
:POIN?	Query number of points in the waveform.	
:COPY <NRf>	Copy arbitrary points to NVRAM: 1 to 4	
:RANG <name>	Select source ranging mode: BEST or FIX	BEST
:DUR	Waveform duration:	
:TIME <NRf>	Set waveform time duration (seconds): 100e-9 to 999999.999 or INF.	INF
:CYCL <NRf>	Set waveform duration in cycles: 1e-3 to 99999999900 or INF	INF
:ARM	Arm waveform function.	
:INIT	Start waveform output.	
:ABOR	Abort waveform output.	
:EXTR	Waveform external trigger commands: *	
[:ENAB] 	Enables/disables mode to externally trigger the waveform generator: = ON or OFF.	OFF
:ILIN <NRf>	Specify trigger link input trigger line: <NRf> = 0 (none) or 1 to 6.	0
:IGN 	Sets whether or not to restart waveform upon retriggering: = ON or OFF.	OFF
:IVAL <NRf>	Sets inactive value to output before/after waveform: <NRf> = -1 to +1.	0.00

* Available with firmware revision A03 and later.

Table B-7
Status command summary

Command	Description	Default
STATus	Commands status registers:	Note 1
:MEASurement	Measurement event registers:	
[:EVENT]?	Read the event register.	Note 2
:ENABle <NDN> or <NRf>	Program the enable register.	Note 3
:CONDition?	Read the condition register.	
:OPERation	Operation event registers:	
[:EVENT]?	Read the event register.	Note 2
:ENABle <NDN> or <NRf>	Program the enable register.	Note 3
:CONDition?	Read the condition register.	
:QUESTionable	Questionable event registers:	
[:EVENT]?	Read the event register.	Note 2
:ENABle <NDN> or <NRf>	Program the enable register.	Note 3
:CONDition?	Read the condition register.	
:PRESet	Return status registers to default states.	
:QUEue	Read error queue:	
[:NEXT]?	Read the most recent error message.	Note 4
:ENABle <list>	Specify error and status messages for error queue: -999 to +999.	Note 5
:DISable <list>	Specify error and status messages not to be placed in error queue: -999 to +999	
:CLEar	Clears all messages from error queue.	
Parameters:		
<NDN> = #Bxx...x	Binary format (each x = 1 or 0)	
= #Hx	Hexadecimal format (x = 0 to FFFF)	
= #Qx	Octal format (x = 0 to 177777)	
<NRf> = 0 to 65535	Decimal format	

Notes:

1. Commands in this subsystem are not affected by *RST or SYSTem:PRESet. The effects of cycling power, *CLS and STATus:PRESet, are explained by the following notes.
2. Event registers — Power-up and *CLS clears all bits. STATus:PRESet has no effect.
3. Enable registers — Power-up and STATus:PRESet clears all bits. *CLS has no effect.
4. Error queue — Power-up and *CLS empties the error queue. STATus:PRESet has no effect.
5. Error queue messages — Power-up enables error messages and disables status messages. *CLS and STATus:PRESet have no effect.

Table B-8
System command summary

Command	Description	Default
:SYST		
:COMM	Communication interfaces:	
:SEL <name>	Select interface: SERial, GPIB, or ETHernet.	
:GPIB	GPIB interface:	
:ADDR <NRf>	Set primary address: 0 to 30.	
:SER	RS-232 interface:	
:CONT	Handshaking:	
:RTS <name>	Select handshaking: IBFull, RFR, or OFF.	
:PACE <name>	Set flow control: XON or OFF	
:TERM <name>	Set output terminator: CR, LF, CRLF, or LFCR.	
:BAUD <n>	Set baud rate: 300, 600, 1200, 2400, 4800, 9600, 19.2k, 38.4k, 57.6k, or 115.2k.	
:SEND <data>	Send data via RS-232.	
:ENT?	Reads data from serial port.	
:LOC	RS-232 only – Take 622x out of remote.	
:REM	RS-232 only – Put 622x in remote.	
:RWL 	RS-232 only – Enable or disable local lockout.	
:ETH	Ethernet interface (6221 only):	
:ADDR <string>	Set IP address: "n.n.n.n".	
:MASK <string>	Set subnet mask: "n.n.n.n".	
:GAT <string>	Set Ethernet gateway: "n.n.n.n".	
:DHCP 	Enable or disable DHCP.	
:SAVE	Saves Ethernet setting changes.	
:KEY <n>	Simulate key press. See Section 13 of Reference Manual.	
:KCL 	Enable or disable key-click.	ON
:BEEP	Beeper:	
:STAT 	Enable or disable beeper.	ON
:PRES	Return 622x to PRESET default setup.	
:POS <name>	Select power-on setup: RST, PRES, SAV0, SAV1, SAV2, SAV3, or SAV4.	
:ERR?	Query the latest error code and message.	
:CLE	Clears error code and message from Error Queue.	
:TST	System timestamp:	
:RES	Reset timestamp to zero seconds.	
:RNUM	System reading number:	
:RES	Reset reading number to zero.	
:VERS?	Query revision level of SCPI standard.	

Table B-8 (cont.)

System command summary

Command	Description	Default
:ABO	Analog board:	
:SNUM?	Query serial number of analog board.	
:REV?	Query revision level of analog board.	
:DBO	Digital board:	
:SNUM?	Query serial number of digital board.	
:REV?	Query revision level of digital board.	
:PASS	Password:	
:ENAB 	Enable or disable the use of password.	
:CDIS <string>	Disables protected commands. <string> = "password".	
[:CEN] <string>	Enables protected commands. <string> = "password".	
:STAT?	Query state of password: Returns "0" if password protected commands are disabled. Returns "1" if enabled.	
:NEW <string>	Set new password. <string> = "password".	

Table B-9

Trace command summary

Command	Description	Default
TRAC	Commands to control buffer:	Note 1
:CLE	Clear readings from buffer.	
:FREE?	Query memory bytes available in buffer.	
:POIN <n>	Specify buffer size (number of readings to store): 1 to 65536.	Note 2
:ACT?	Query number readings stored in the buffer.	
:NOT <NRf>	Specify number of stored readings that will set the Trace Notify bit (B6) of the measurement event register. Must be less than the TRAC:POINvalue: 1 to (TRAC:POIN -1).	Note 3
:FEED <name>	Select feed for buffer readings: SENS1, CALC1 or NONE	CALC1
:CONT <name>	Set buffer control: NEXT or NEVer	NEV
:TST	Timestamp for buffer readings:	
:FORM <name>	Select timestamp format: ABSolute or DELTa	ABS
:DATA?	Request all readings in buffer.	
:TYPE?	Query type of readings stored in buffer.	
:SEL? <start>, <count>	Request list of stored readings: Requires a starting value and the number of readings (count).	

1. SYSTEM:PRESet and *RST have no effect on the TRACe commands. The listed defaults are power-on defaults.
2. Buffer size is set to the number of delta readings to be performed.
3. The default parameter is one-half the set buffer size (TRACe:POINts / 2).

Table B-10

Trigger command summary

Command*	Description	Default
INIT	Trigger initiation:	
[:IMM]	Initiate one trigger cycle.	OFF
ABOR	Reset trigger system.	
ARM	Arm layer commands:	
:SOUR <name>	Select event detector: IMM, TIM, BUS, TLIN, BST, PST, NST, or MAN.	
:SIGN	Bypass ARM control source.	
:TIM <n>	Set timer interval (seconds): 0 to 99999.99. 1msec resolution.	0.1
:DIR <name>	Control ARM source bypass: SOUR or ACC.	ACC
:ILIN <NRf>	Set ARM input signal line: 1 to 6.	1
:OLIN <NRf>	Set ARM output signal line: 1 to 6.	2
:OUTP <name>	Enable/disable ARM output trigger: TENT, TEX, or NONE.	NONE
TRIG	Trigger layer commands:	
:SOUR <name>	Select event detector: IMM or TLIN.	IMM
:SIGN	Bypass TRIG control source.	
:DIR <name>	Control TRIG source bypass: SOUR or ACC.	ACC
:ILIN <NRf>	Set TRIG input signal line: 1 to 6.	1
:OLIN <NRf>	Set TRIG output signal line: 1 to 6.	2
:OUTP <name>	Enable/disable TRIG output trigger: SOUR, DEL, or NONE.	NONE

* Arm layer commands control entire sweep. Trigger Layer commands control individual sweep steps.

Table B-11

Units command summary

Command	Description	Default
UNIT	Commands to set reading units for Delta, Pulse Delta, and Differential Conductance:	
[:VOLT]	Volts readings are sent from 2182/2182A to 622x.	
[:DC] <name>	Specify reading units*: V, OHMS, W, or SIEM.	V
:POW	Power reading type for Pulse Delta (6221):	
[:TYPE] <name>	Set power units reading type: PEAK or AVER.	AVER

* The <name> parameter for Siemens can be sent as S, SIEM, or SIEMENS.

Index

A

- Accessories 1-4
- Analog filter 3-5
- Applications 3-16
- Arbitrary waveforms 7-7
- Arming and Starting the Test 5-10
- Averaging filter 6-1
 - Commands 6-5
 - Filter count 6-2
 - Filter window 6-4
 - Moving filter 6-3
 - Repeating filter 6-3
 - Setup and control 6-4

B

- Banana jack Guard 2-8
- Buffer 6-7
 - Buffer data elements 6-7
 - Buffer size 6-7
 - Buffer statistics 6-8
 - Buffer timestamp 6-8
 - Commands 6-9
 - Recalling readings 6-8
 - Storing readings 6-8

C

- Cable Guard 2-8
 - Connections 2-11
- Capabilities 1-2
- Communications
 - Model 2182/2182A 5-9
 - Model 622x 5-9
- Compliance 3-3
- Compliance overshoot 3-3
- Connections
 - DUT 5-8
 - System 5-5
- Connections to DUT 2-9
- Connectors
 - Digital I/O 1-9
 - Ethernet 1-8
 - Guard 1-9
 - IEEE-488 1-8
 - Interlock 1-9
 - LO 1-9
 - Output 1-8
 - Power module 1-9
 - RS-232 1-9
 - Trigger Link 1-9

- Contact information 1-3
- Cooling vents 1-9

D

- Default settings 1-18
- Delta 5-2, 5-13
 - Configuration 5-15
 - Measurement units 5-15
 - Operation 5-16
 - Setup commands 5-19
 - Triggering sequence 5-10, 5-16
- Differential Conductance 5-2, 5-34
 - Calculations 5-36
 - Configuration 5-37
 - Measurement process 5-34
 - Measurement units 5-37
 - Operation 5-38
 - Setup commands 5-41
- Disabling front panel 1-12

E

- Editing 1-14
 - Compliance 1-14
 - Source 1-14
- Error and status messages 1-17
- Ethernet (6221) 5-6

F

- Features 1-2
- Floating the current source 2-9
- Frequency variable resistor (FVR) 2-3
- Front panel summaries 1-4

G

- Getting Started 4-1, 7-1
- Ground points 2-3
- GUARD banana jack 2-3
- Guarding 5-8
- Guards 2-8, 2-10

H

- Heat sink 1-9

I

- IEEE-488 5-6
- Inspection 1-3
- Interface selection 1-17
 - Ethernet 1-17
- Interlock 2-4

K

- Keys
 - Function 1-6
 - Operation 1-6
 - Output control 1-7
 - Range 1-7
 - Special 1-6

L

- Leakage current 2-8
- Line power connection 1-11
- LO banana jack 2-3

M

- Math
 - Commands 6-6
 - $mX+b$ and mX/b 6-5
- Measurement units 5-13
- Menu navigation 1-14
- Menus 1-13
 - CONFIG 1-13
 - Direct access 1-13

O

- Operating boundaries 3-4
- Optional command words 1-19
- Options 1-4
- Output configurations 2-5
- Output connectors 2-2
- Output power 3-3
- Output response 3-5

P

- Password 1-16
- Phone number 1-3
- Power module 1-9
- Power switch 1-6
- Power-on setup 1-19
- Power-up 1-11
- Pulse Delta 5-2, 5-21
 - Configuration 5-26
 - Duty Cycle 5-26
 - Fixed output 5-22
 - Measurement units 5-22
 - Operation 5-29
 - Pulse Delta process 5-21
 - Setup commands 5-32
 - Sweep output 5-22

Q

- Query commands 1-19

R

- Read commands
 - Buffer 5-13
 - Pre-math 5-13
- Rear panel summaries 1-8
- Response speed (6221) 3-7
- Rotary knob 1-7
- RS-232 5-6

S

- Safety symbols and terms 1-3
- SCPI programming 1-19
- Serial communications 5-5
- Settling time 3-7
- Shielding 2-10
 - Noise shield 2-10
 - Safety shield 2-11
- Sink operation 3-3
- Source and compliance editing 3-8
- Source output commands 3-15
- Source preset 1-12, 3-12
- Source ranges 3-2
- Sourcing current 3-12
- System connections
 - PC control 5-6
 - Stand-alone system 5-5

T

- Test fixture 2-12
- Test systems
 - PC control 5-4
 - Stand-alone 5-4
- Triax cable 2-9
 - Cable Guard 2-8
- Triax connector 2-2
 - Inner shield 2-6
 - Output low 2-7
- Trigger Link 5-6
- Triggered waveforms 7-7

U

- Unpacking 1-3

W

- Warranty information 1-3

Specifications are subject to change without notice.
All Keithley trademarks and trade names are the property of Keithley Instruments, Inc.
All other trademarks and trade names are the property of their respective companies.

KEITHLEY

A G R E A T E R M E A S U R E O F C O N F I D E N C E