



COMBUSTIBLE GAS LEAK DETECTOR INSTRUCTIONS



Fig. 1:

P/N 69310

COMBUSTIBLE GAS LEAK DETECTOR

- Powered with 6 x 1.5V AAA alkaline batteries
- User configurable parameters
- Sound and visual indication in case of alarm
- Auto-shut-off function

OVERVIEW

This digital handheld gas leakage detector is equipped with a flexible wand (for reaching the leaks) with a gas sensor mounted at the end for detection of low concentrations of hydrocarbons in gas appliances and pipes.

WARNING: This device is not a measurement instrument.

- This device can detect Methane (CH₄) or Liquid Propane Gas (LPG), as well as other Hydrocarbons.
- The gas concentration is shown as 4-digits on the LCD, as well as through a bar-graph ranging from 0 to 100% of the full scale.
- The detector can be operated with either alkaline batteries or rechargeable batteries. The operation with a 12V external power adaptor is also available as an option.
- When a power adapter is used the batteries installed in the battery compartment are disconnected and the external adaptor does not recharge the batteries.
- In order to recharge on-board batteries, an external battery charger must be used.
- To save battery during operation, this detector features an autozero and auto-shut-off function.

OPERATION

Beginning Use

Before first use of the detector, the operator must take the following actions:

- Insert the batteries in the battery compartment. In order to open the plastic door please apply a slight pressure with a finger or with the help of a small screwdriver on the plastic tooth (see 'a' in Fig. 2); then insert batteries paying attention to the correct polarity.
- Alternatively connect an external adaptor (optional) and plug in the connector (see Fig. 3), then plug adaptor in the outlet.

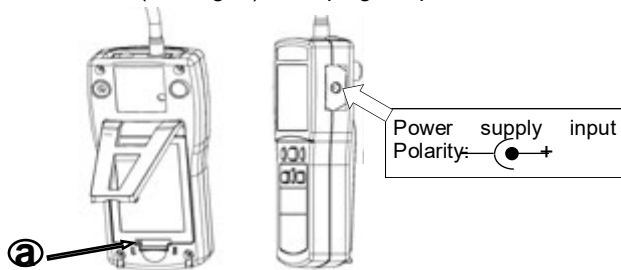

Fig. 2: Battery compartment. Fig. 3: Power supply input.

Functions

'⊙' On/Off key

- To turn the detector On or Off press the '⊙' key.
- When the detector is turned on, a short beeping sound will play and the sensor starts the pre-heating phase, which lasts 45 seconds.
- During this phase the detector displays the word 'HEAT' and the time remaining.
- When the pre-heating is completed the auto-zero phase is initiated. This will last 6 seconds and identified with another short beeping sound. Once this is completed, another longer beeping sound indicates the detector is ready for operation.
- During the normal operation, when no gas is detected, the detector will issue a short beep every 2 seconds.
- When a leak is detected, the rate of the sound will increase according to the measured concentration.
- The detector is set from the factory with the auto-shut-off feature turned on and the shutoff time set to 10 minutes.
- This means that the detector will automatically shutoff after ten minutes from being turned on.

- To temporarily turn-off this feature, until a manually turned-off, press the '⊙' key for at least 4 seconds while turning on the unit. To turn the detector off press the '⊙' key: this is confirmed with three short beeps.

>0< 'AUTO ZERO Key

- When the detector is on, press this key to start the auto-zero procedure.
- The auto-zero time is 6 seconds long, starting with a beeping sound and with 4 '0.000' digits flashing on the LCD.
- During this auto-zero procedure, the detector samples the actual gas concentration and assumes that as a zero baseline for any following measurement.
- When this zeroing is completed, the detector will play a long beeping sound.

AUTOMATIC Zero Drift Adjustment

- With no gas present, the detector checks its zero level and performs an automatic drift adjustment.
- This compensation is performed every 2 seconds in order to compensate any possible sensor drift due to temperature variations.
- When the sensor detects the presence of gas it switches to the gas detection operation.

'H' Hold Key

- When the 'H' key is pressed, the 'HOLD' mode is activated. During this mode, the current value is 'frozen' on the lower 4 digits on the display. When in this mode the detector displays 'HOLD' and plays a short beep.
- While the operator is in this mode, the upper 4-digits on the display will keep on showing the current measured value, this allows the operator the ability to see variations. While 'HOLD' is active, the lower 4-digits display the 'frozen' value.
- If the 'H' key is pressed again the detector will exit from the 'HOLD' mode and a short beep will play as a confirmation.

'UNIT' Measurement Unit Key

- When this key is pressed the units of measurement on the display is selected.
- Each time the 'UNIT' key is pressed, the detector will cycle among the available measurement units, according to the following sequence (Starting with the unit currently selected):

=> ppm => %vol => % L.E.L. => ppm =>

- Every time the unit is changed, the choice is automatically stored in the detector's memory. This creates the default units for the next time the detector is turned on.

'SET' Key

- When this key is held for at least 3 seconds the user enters a mode in which they can set the general parameters for the detector operation.
- There are three parameters (P1, P2, and P3) the user can select between by pressing the 'SET' key.
- Once a parameter is selected, its value can be modified with the following keys:

'FUNC' Key: Increases the value (if numerical) or switches between On and Off cyclically (if non-numerical).

'UNIT' Key: Decreases the value (if numerical) or switches between On and Off cyclically (if non-numerical).

The Parameters to be Adjusted are the Following:

P1: Acoustic Feedback Enable/Disable

- This parameter is identified with the label 'Set 1'.
- Its value enables or disables the internal buzzer for the sound feedback.
- Press the 'UNIT' or the 'FUNC' key to change the actual value. The detector is set from the factory with the feedback enabled (Set 1=On).

P2: Auto-Shut-Off Time

- From the parameter 'Set 1' if the 'SET' key is pressed once, the user gets access to parameter 'Set 2'. 'SET 2' allows the user the ability to adjust the auto-shut-off time. The 'UNIT' key decreases the current value and the 'FUNC' key increases it.
- The allowed values for this parameter are in the range from 1minute to 30 minutes in 1 minute increments.
- To disable this auto-off feature (turned on until a manual turn-off) the user must increase or decrease the parameter value until the 'OFF' value is displayed.

P3: Buzzer on Alarm Enable/Disable

- From the parameter 'Set 2' if the 'SET' key is pressed once more, the user gets access to parameter 'Set 3' which allows the user the ability to enable or disable the buzzer sound in case of an alarm.
- Press the 'UNIT' or the 'FUNC' key to change the actual value.
- The detector is set from the factory with the alarm buzzer enabled (Set 3=On).
- Pressing the 'SET' key again will result in exiting the parameters configuration mode. When exiting the detector will store all changes in the detector's memory as the preferences.

OVER-RANGE FUNCTION

- This function is continuously checking the measured concentrations to verify that they remain within the detector's full range limits.
- When the full range value is exceeded, the internal buzzer will start beeping at the maximum repetition rate and the 'ALM' symbol will be turned on and the lower display will show the label 'OFL' (overflow).

LOW BATTERY FUNCTION

- The detector monitors the battery level and when it is below a certain pre-set value, the low-level battery icon '  ' is displayed in the upper right side of the screen.
- When this symbol is turned-on, the detector is still operational.
- When the battery voltage falls below a critical level, the words 'Lo Batt' are shown on the display and the detector stops operation. The only action allowed to the user is the turn-off.
- When the detector is turned on again and the battery voltage is in the valid range, all the functions are enabled.
- For battery replacement please follow the directions explained in the paragraph 'Beginning use'.

BUZZER

- This detector has an internal buzzer for the indication of measured concentration and as a sound feedback on some user actions.
- When the detector is detecting a gas concentration greater than zero, the rate of the 'beeps' increases according to the concentration level.

SENSOR FAIL

- The detector periodically checks the sensor status. When the sensor is found to be defective, the buzzer sound is set to continuous (when the Buzzer Alarm feature is Enabled) and the words 'SEnS FAIL' are shown on the display.

TECHNICAL FEATURES

| | |
|------------------------|-----------------------------------|
| Power supply: | 9V, 6x1.5V AAA alkaline batteries |
| External power supply: | 12 Vcc, 100 mA |
| Battery life: | 4 hours minimum |
| Battery level: | 6.00 V (instr. operational) |
| Low-Batt level: | 5.50 V (instr. stopped) |
| Sensor type: | Semiconductor |
| Pre-heating time: | max. 45 seconds fixed |
| Auto-shut-off time: | OFF, 1- 30 minutes |
| Display: | LCD TN |
| Protection grade: | IP 20 |
| Operating temperature: | 0°C .. +40°C |
| Storage temperature: | -10°C .. +50°C |
| Humidity limits: | 20% .. 80% RH non condensating |

Enclosure:

Material: ABS HB self-extinguishing

Sensor Failure

When the detector sensor is found to be defective, the buzzer sound is on continuously (when the Buzzer Alarm feature is Enabled) and the words 'SEnS FAIL' are shown on the display.

- 1 Remove sensor sticker from protective cover at the end of the wand (see figure 4)
- 2 Unscrew sensor protective cover
- 3 Pull sensor straight out
- 4 Align tab in end of the wand with the tab on the sensor and insert sensor until fully seated
- 5 Screw on sensor protective cover
- 6 Apply new sensor sticker
- 7 Turn on unit and allow unit to heat and resume testing

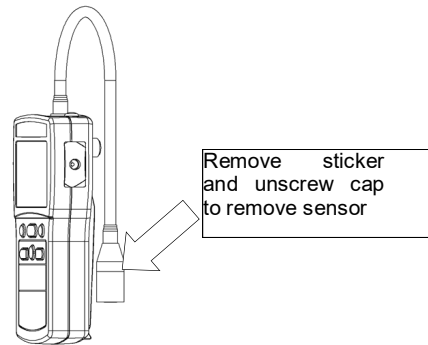

Fig. 4: Sensor change

Color: Blue
Dimensions: 2.8x5.9x1.5in (72 x 151 x 37mm). (W x H x D)
Weight: ~.7lbs (~ 312 gr.)
Sensor Wand Flexible Length: 10.6in (270 mm)
Accessories: External adaptor 230V~/12V= 100mA (available upon request)

WARRANTY

The **Combustible Gas Leak Detector** is guaranteed for **12 months** from purchasing document date.

YELLOW JACKET® undertakes to repair or replace, free of charge, those parts that, in its opinion, are found to be faulty during the warranty period. The products which are found defective during the above mentioned periods of time must be delivered to YELLOW JACKET® postage paid. The following cases are not covered by this warranty: accidental breakage due to transport, inappropriate use or use that does not comply with the indications in the product's instruction manual or quick start guide.

Any mistreatment, repairs and modifications to the product not explicitly authorized by YELLOW JACKET® shall invalidate the present warranty.

