

Waterproof RJ45 Splice Coupler Instructions

NOTE: 2 EA RJ45 CONNECTORS REQUIRED (NOT INCLUDED)

P/N 740C

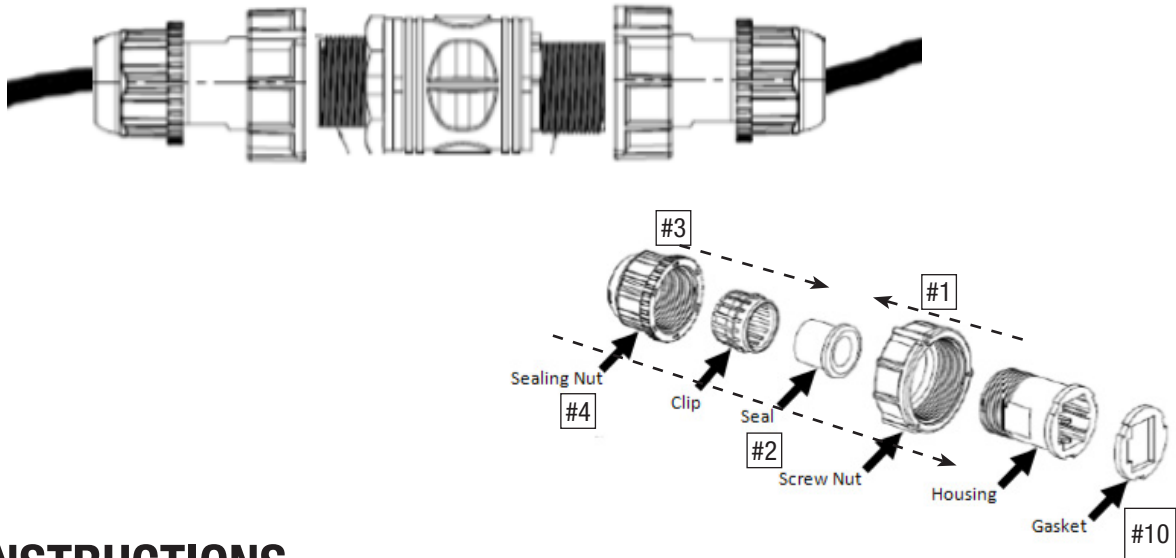

INSTRUCTIONS (EACH RJ45 Connector Requires this Prep)

1. Slide screw nut over backend of housing until it stops at the flange.
2. Insert seal into clip.
3. Insert the clip & seal assembly into the backend of the housing until fully seated.
4. Screw sealing nut onto the backend of the housing and STOP at the point of feeling some resistance from the gasket.
5. Housing assembly is now ready for the cable. Insert cable through the backend and slide down, leaving enough cable to prep and terminate the RJ45 connector.
6. Once the RJ45 is terminated, slide the housing assembly up to the backend of the RJ45.
7. Rotate RJ45 until the locking tab is in the center of the alignment pins.
8. Squeeze locking tab and insert RJ45 until fully seated.
9. Secure cable by turning sealing nut until tight at the backend of the housing assembly.
10. Remove adhesive backing from the gasket. Push screw nut back. Apply gasket to housing using the RJ45 nose profile as a guide. Be sure adhesive is facing housing.
11. RJ45 #1 is ready. Now repeat and prep RJ45 #2.

**Test Equipment
Depot**
1-800-517-8431

99 Washington Street
Melrose, MA 02176
Phone 781-665-1400
Toll Free 1-800-517-8431

Visit us at www.TestEquipmentDepot.com

We Make Connections EZI!™