

PIE 820-ELITE

Multifunction Process Calibrator

mA • V • TC • Ω • RTD • Hz

Operating Instructions



CE

PIE

**Test Equipment
Depot**



1-800-517-8431

99 Washington Street

Melrose, MA 02176

Phone 781-665-1400

Toll Free 1-800-517-8431



Visit us at www.TestEquipmentDepot.com

Contents

General Operations

Accessories.....	3
Carrying Case, Boot & Changing Batteries	4
Storing EZ-CHECK Outputs & Connections	5

Basic Operation

Switches & Knobs.....	6
Double Click Menus.....	8
Stepping & Ramping / Auto Off.....	10
Backlight	11

Functions and Hookup Diagrams

Milliamp

Source mA	12
Simulate 2 Wire Transmitters.....	13
Read mA	14
Power/Measure Transmitters	15
Power/Measure Transmitters with Leak Detection	16

Voltage & Millivolt

Source V & mV	18
Read V & mV	19

pH

Source pH.....	20
----------------	----

Thermocouple

Source T/C.....	22
Read T/C Sensors.....	23

Resistance

Source Resistance.....	24
Read Resistance & Check Continuity.....	25

RTD

Source RTD	26
Read RTD Sensors.....	27

Frequency

Source KHz, Hz & CPM.....	28
Read KHz, Hz & CPM	29

Pressure

Read Pressure	30
---------------------	----

Specifications

General	32
Thermocouple Ranges & Accuracies.....	37
RTD Ranges & Accuracies	40

Warranty

Warranty & Additional Information	41
---	----

General Information

Technician friendly operation

The unique and intuitive *EZ-DIAL Double Click Menu* makes it easier to setup than other multifunction calibrators. Uses the same menus as the single function PIE Evolution Calibrators.

Use it as a milliamp and voltage calibrator

Source 0 to 24.000 mA, 0 to 10.250 V dc, -20.000 to 99.999 mV and -500.00 to 999.99 mV

Read to 24.000 mA, 60.00 V dc ± 99.999 mV & ± 999.99 mV

Simulate 2-Wire Transmitters & Power up transmitters & loops

Calibrate in temperature with 0.1°C/°F resolution

Types J, K, T, E, R, S, B, N, G, C, D, L (J DIN), U (T DIN) & P II Pt 100 Ohm (3850, 3902, 3916, 3926) & 1000 Ohm (3850) RTD

Copper 10 & 50 Ohm, Nickel 100 and 120 Ohm RTD

Checkout flow and vibration systems

Source & read frequency from 0 to 2000 CPM (Counts-Per-Minute), 0.00 to 999.99 Hz, 0.0 to 9999.9 Hz and 0.000 to 20.000 kHz.

Checkout resistance instruments, loop & wiring problems

Source and read resistance from 0.00 to 410.00 and 0.0 to 4001.0 ohms. 'Beep' out connections with the built-in continuity checker.

Troubleshoot loop problems

Quickly diagnose ground fault and current leakage with patented loop diagnostic technology (US Patent 7,248,058).

Simulate pH probes into transmitters & analyzers

Source from 0.000 to 14.000 pH @ 25°C (77°F) corresponding to -414.12 to +414.12 mV to verify the pH system is operating properly before placing the probe into calibrated buffers.

Measure pressure with optional pressure modules

Three modules for 30 PSI/2 bar gauge, 500 PIS/35 bar gauge and 30 PSI/2 bar absolute

Guaranteed compatible with all instrumentation

Works with Rosemount & Honeywell Smart Transmitters, PLCs, DCSs, Multi-Channel Recorders and other pulsed excitation devices.

Easy to read

Turn on the backlight & easily see the display in dark areas.

Quickly set any three outputs plus automatic stepping & ramping

Easily set any value quickly with the adjustable "DIAL" plus store any three output settings for instant recall with the EZ-CHECK™ switch. Choose between 2, 3, 5 & 11 steps or RAMP to increase and decrease the output between Zero and Span from 5, 6, 7, 8, 10, 15, 20, 25, 30 and 60 seconds.

Measure temperature sensors, frequency pickups, mA & V

Check the values of your process sensors. Instantly recall MAX and MIN values to see process variability.

Accessories

INCLUDED:

Four "AA" Alkaline batteries, Certificate of Calibration	
Evolution Hands Free Carrying Case	Part No. 020-0211
Blue Rubber Boot	Part No. 020-0212
Test Leads - one pair: with banana plug & alligator clips	Part No. 020-0207
Evolution RTD Wire Kit	Part No. 020-0208
2 Red & 2 Black Leads with Banana Plugs & Spade Lugs	

OPTIONAL:

Ni-MH 1 Hour Charger with 4 Ni-MH AA Batteries (100-120 V AC input for North America Only)	Part No. 020-0103
T/C Wire Kit 1* for Types J, K, T & E	Part No. 020-0202
T/C Wire Kit 2* for Types B, R/S & N	Part No. 020-0203
*Three feet (1 meter) of T/C extension wire, stripped on one end with a miniature T/C male connector on the other end.	
Female BNC to Banana Plug Adaptor	Part No. 020-0218

Operating Instructions

FIELD & BENCH USE

PIE 820-ELITE comes with a carrying case designed for hands-free operation and a rubber boot with a built-in tilt stand. The PIE 820-ELITE is held in the case by elastic straps for use with the carrying case open. The tilt stand is easily raised by pulling the stand until it locks into place.



CHANGING BATTERIES

Low battery is indicated by “**BAT**” on the display. Approximately one to four hours of typical operation remain before the PIE 820-ELITE will automatically turn off. To change the batteries; remove the rubber boot, remove the battery door from the back of the unit by sliding the door downward. This allows access to the battery compartment. Replace with four (4) “AA” 1.5V batteries being careful to check the polarity. Replace the battery door and replace the boot. All stored configuration options (T/C Type, EZ-CHECK Memories, etc.) are reset to factory settings when the batteries are removed.

Note: Alkaline batteries are supplied and recommended for typical battery life and performance. Optional rechargeable batteries (charged externally) are available.

Operating Instructions

STORING HI and LO EZ-CHECK Source Outputs

Speed up your calibration by storing Span & Zero output setting for instant recall with the EZ-CHECK switch.

- 1) Store your high (SPAN) output temperature by moving the EZ-CHECK switch to the **HI** position and turning the EZ-Dial knob until the desired output value is on the display. Press and hold the EZ-Dial knob until **STORED** appears to store the value. Release the EZ-Dial knob.
- 2) Store your low (ZERO) output value by moving the EZ-CHECK switch to the **LO** position and turning the EZ-Dial knob until the desired output value is on the display. Press and hold the EZ-Dial knob until **STORED** appears to store the value. Release the EZ-Dial knob.
- 3) Instantly output your SPAN and ZERO output settings by moving the EZ-CHECK switch between HI and LO. You may also select any third output setting (such as mid-range) using the SET position on the EZ-CHECK switch.

Connections

PIE 820-ELITE has banana jacks compatible with unshielded or retractable banana plugs. Included with your calibrator are: a pair of test leads with alligator clips for mA, V, pH & Hz connections. Four test leads with spade lugs are also included for 2, 3 and 4 Wire RTD connections. Thermocouple connections are made through a miniature thermocouple socket.

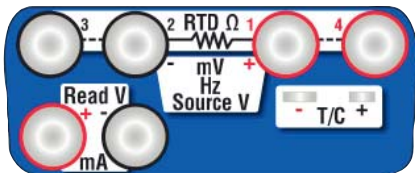

Operating Instructions

Basic Operation

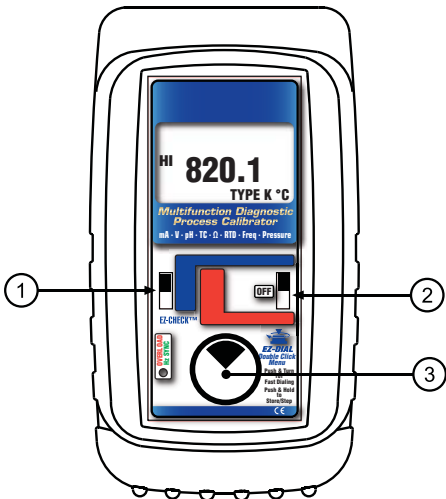

① EZ-CHECK™ SWITCH

SOURCE: Instantly output two preset settings by moving the EZ-CHECK™ switch to the “LO” position or “HI” position. For fast three point checks select the “SET” position. The PIE 820-ELITE will remember the last “SET” value, even with the power off. These values can easily be changed to suit the calibration requirements. The values stored in the HI and LO positions are also used for Auto Stepping.

READ: Slide the switch to the SET position. The PIE 820-ELITE will display the current reading from the sensor or device being measured. Slide the switch to MAX and the highest value measured since turn-on or reset will be displayed; slide the switch to MIN and the lowest value measured since turn-on or reset will be displayed.

Operating Instructions

Basic Operation

② SOURCE/OFF/READ Switch

Select “**SOURCE**” to output mA, V, T/C, Ohms, RTD or frequency.
Select “**READ**” to read mA, V, T/C, Ohms, RTD or frequency.

③ EZ-DIAL™ KNOB

SOURCE: Turn the knob to adjust the output level. Turn clockwise to increase the output, counter clockwise to decrease the output in one least significant digit steps at a time. Push down and turn the EZ-DIAL knob for faster dialing.

Press and hold the knob for two seconds to store desired EZ-Check™ HI/LO points in SOURCE mode. Continue to press and hold the knob for two more seconds to start the automatic ramping.

READ: Press and hold to transfer the current temperature into the EZ-Check™ MIN/MAX points. This clears the MIN/MAX readings which will update as the input value changes.

SELECTING FUNCTIONS

The EZ-DIAL knob is used to setup the PIE 820-ELITE to match the instrument to be calibrated or signal to be measured. Each time you turn on the PIE 820-ELITE the LCD displays the following screen for about 1 second followed by operating in the function used the last time it was operated.

**PIE 820-ELITE
DOUBLE CLICK
EZ-DIAL KNOB
FOR CONFIGURATION**

Double Click the EZ-DIAL knob to change the function of the calibrator and to select ranges, units and other user settings. Each function (mA, V, T/C, Ohms, RTD, Frequency) has two pages of menus. The first menu page has settings for the function and the second menu page has settings for STEPPING, AUTO OFF and BACKLIGHT. Settings are remembered even with the power off but are reset when the batteries are changed.

Operating Instructions

Double Click Menus

Double click the EZ-DIAL knob to access the Double Click Menus to select each function and the options for each function. Available choices are shown in grey.

Source mA & Simulate 2 Wire Transmitters

> EXIT
FUNCTION mA
MODE SOURCE 2W SIM
UNITS mA %
HART 250Ω ON OFF

Read mA, Power/Measure Transmitters & Leak Detect

> EXIT
FUNCTION mA
MODE READ PWR MEAS PWRM LEAK
UNITS mA %
HART 250Ω ON OFF

Source V & mV

>EXIT
FUNCTION V
RANGE 10V 100mV 1V

Read V & mV

>EXIT
FUNCTION V
RANGE 10V 1V 60V 100mV

Source pH

> EXIT
FUNCTION pH

Source & Read Frequency

> EXIT
FUNCTION FREQ
RANGE 20KHZ 10000HZ 1000HZ 2000CPM

Operating Instructions

Double Click Menus

Source & Read Thermocouples

> EXIT
FUNCTION T/C
UNITS °C °F
T/C TYPE J K T E R S B G C D L U P
COLD JUNC ON

Source RTD

> EXIT
FUNCTION RTD
UNITS °C °F
RTD Pt 100 $\alpha=3850$ [* RTD Types]
WIRE MODE 234W

Read RTD

> EXIT
FUNCTION RTD
UNITS °C °F
RTD Pt 100 $\alpha=3850$ [* RTD Types]
WIRE MODE 2W 3W 4W

*Pt 100 $\alpha=3902$,
 $\alpha=3916$, $\alpha=3926$
Pt 1000 $\alpha=3850$;
Cu 10 $\alpha=4274$,
Cu 50 $\alpha=4280$
Ni 120 $\alpha=6720$,
Ni 110 $\alpha=5801$

Source Ohms

>EXIT
FUNCTION OHMS
RANGE 400 Ω 4000 Ω
WIRE MODE 234W

Read Ohms

>EXIT
FUNCTION OHMS
RANGE 400 Ω 4000 Ω CONT
WIRE MODE 2W 3W 4W

Read Pressure

>EXIT
FUNCTION PRESSURE
UNITS psi inH2O* inHg bar mbar kPa Mpa ksc cmH2O*
mmH2O* mmHg *Multiple temperatures in °C & °F

Operating Instructions

Double Click Menu - STEPPING, AUTO OFF & BACKLIGHT

To change the Automatic Stepping settings

Double click the ③ DIAL KNOB at any time the unit is on and the following typical display (will be different for each FUNCTION) will appear for 15 seconds:

>	EXIT	
	FUNCTION	mA
	MODE	SOURCE
	UNITS	mA
	HART 250Ω	ON

Turn the ③ DIAL KNOB to move to the second menu page.

Turn the ③ DIAL KNOB to move through the menu. Press the ③ DIAL KNOB to toggle between OFF and ON or to change the STEPS and the STEP TIME settings. These settings are remembered even with the power off.

>	EXIT	
	STEPS	3
	STEP TIME	5
	AUTO OFF	ON
	BACKLIGHT	ON

EXIT MENU - exits this menu immediately and saves any changes. Menu will automatically exit after 15 seconds of inactivity.

AUTO OFF - If AUTO OFF is ON, the unit will turn off after 30 minutes of inactivity to save battery life. If AUTO OFF is OFF the unit will stay on until the POWER SWITCH is moved to the off position.

Operating Instructions

Double Click Menu - STEPPING, AUTO OFF & BACKLIGHT

STEPS - pressing the knob will cycle through 2, 3, 5, 11 and RAMP. The endpoints of the steps or ramp are based on the values stored in the **HI** and **LO** EZ-CHECK outputs.

2 steps will automatically switch between the values stored in the HI & LO EZ-CHECK (0 & 100%).

3 steps between the HI, Midpoint and LO EZ-CHECK (0, 50 & 100%).

5 steps between the HI and LO EZ-CHECK in 25% increments (0, 25, 50, 75 & 100%).

11 steps between the HI and LO EZ-CHECK in 10% increments (0, 10, 20...80, 90 & 100%).

RAMP continuously ramps up and down between the HI and LO EZ-CHECK outputs.

STEP TIME - pressing the knob will cycle through 5, 6, 7, 8, 9, 10, 15, 20, 25, 30 and 60 seconds.

To start the Automatic Stepping

Start automatic stepping or ramping by placing the EZ-CHECK Switch into the HI or LO position then press and hold the ③ DIAL KNOB for 6 seconds (the word STORE will appear on the display after 3 seconds and continue to press the EZ-DIAL KNOB) until the word STEPPING appears on the display. The word STEPPING will appear on the display anytime the selected automatic function is running. Stop the stepping by again pressing and holding the ③ DIAL KNOB for 3 seconds.

BACKLIGHT - If BACKLIGHT is ON the backlight will light all the time the unit is powered up. For maximum battery life turn the backlight off when using the calibrator in areas with enough ambient light to read the display.

mA SOURCE/ % SOURCE (Percent of 4 to 20 mA)

Choose this function to provide an output from 0.000 to 24.000 milliamps. The compliance voltage is a nominal 24 VDC to provide the driving power to your milliamp receivers.

Move the power switch ② to SOURCE then Double Click the EZ-DIAL knob to get into the Double Click Menu. Turn the knob to scroll through the settings and press the knob to make your selection. Select mA for the FUNCTION and SOURCE for the MODE. Choose either mA or % and whether you need the 250Ω HART resistor active in the loop.

Connect the output leads of the PIE 820-ELITE to the inputs of the device being calibrated, making sure to check polarity. Red lead to the plus (+) input and black lead to the minus (-) input.

Instantly output your SPAN and ZERO output settings by moving the EZ-CHECK switch between HI and LO (defaults to 20 & 4 mA). You may also select any third output setting (such as mid-range) using the SET position on the EZ-CHECK switch. The output is adjusted in 0.001 mA (0.01%) increments by turning the knob ③. Press and turn the knob for faster dialing with 0.100 mA (1.00%) increments.

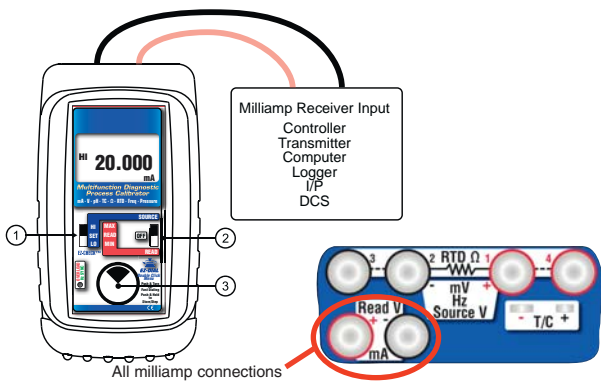

All milliamp connections

2 Wire SIM mA, 2 Wire SIM % (Percent of 4 to 20 mA)

Choose this function to simulate a 2 Wire Transmitter output from 0.000 to 24.000 milliamps. Operates in loops with power supply voltages from 2 to 60 VDC.

Move the power switch ② to SOURCE then Double Click the EZ-DIAL knob to get into the Double Click Menu. Turn the knob to scroll through the settings and press the knob to make your selection. Select mA for the FUNCTION and 2W SIM for the MODE. Choose either mA or % and whether you need the 250 Ω HART resistor active in the loop.

Connect the output leads of the PIE 820-ELITE to the inputs of the device being calibrated, making sure to check polarity. Red lead to the plus (+) input and black lead to the minus (-) input.

Instantly output your SPAN and ZERO output settings by moving the EZ-CHECK switch between HI and LO (defaults to 20 & 4 mA). You may also select any third output setting (such as mid-range) using the SET position on the EZ-CHECK switch. The output is adjusted in 0.001 mA (0.01%) increments by turning the knob ③. Press and turn the knob for faster dialing with 0.100 mA (1.00%) increments.

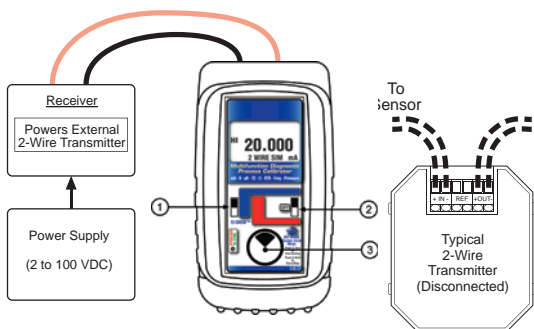

READ mA, READ % (Percent of 4 to 20 mA)

Choose this function to measure from 0.000 to 24.000 milliamps or -25.00 to 125.00%.

Move the power switch ② to READ then Double Click the EZ-DIAL knob to get into the Double Click Menu. Turn the knob ③ to scroll through the settings and press the knob to make your selection. Select mA for the FUNCTION and READ for the MODE. Choose either mA or % and whether you need the 250Ω HART resistor active in the loop.

Connect the red input lead (+) of the PIE 820-ELITE to the more positive point of the break and the black input to the more negative point.

Signals below 0 mA or open circuits are indicated by 0.00 mA (-25.0%) on the display. Signals above 24 mA are current limited by protection circuitry with "OVERRANGE" flashed on the display and the red OVERLOAD LED lit.

The PIE 820-ELITE measures the input signal and constantly updates the display with the current reading. Move the EZ-CHECK switch ① to MAX to see the highest reading and to MIN to see the lowest reading. Press and hold the knob ③ to clear the MAX and MIN readings.

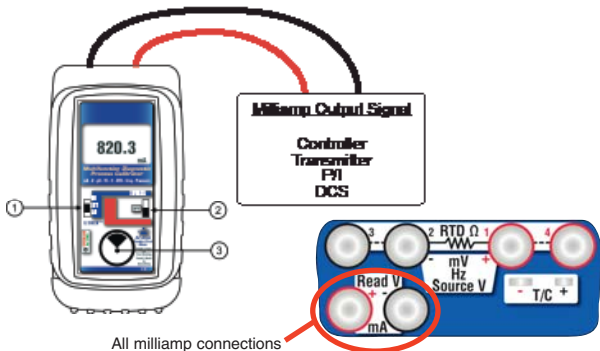

Power/Measure mA, Power/Measure % (Percent of 4 to 20 mA)

Choose this function to simultaneously supply power to a 2 Wire Transmitter while displaying the 4.000 to 20.000 mA output of the transmitter.

Move the power switch ② to READ then Double Click the EZ-DIAL knob to get into the Double Click Menu. Turn the knob ③ to scroll through the settings and press the knob to make your selection. Select mA for the FUNCTION and PWR MEAS for the MODE. Choose either mA or % and whether you need the 250Ω HART resistor active in the loop.

Disconnect one or both input wires from the device to be calibrated. Connect the red source lead of the PIE 820-ELITE to the plus (+) input of the device and the black source lead to the minus (-).

The PIE 820-ELITE supplies a nominal 24 volts DC at 24 mA to the 2 Wire Transmitter. The current passed by the transmitter will be accurately displayed by the PIE 820-ELITE. Calibrate the transmitter in the usual manner and disconnect the PIE 820-ELITE. Signals above 24 mA are current limited by protection circuitry with "OVERRANGE" flashed on the display and the red OVERLOAD LED lit.

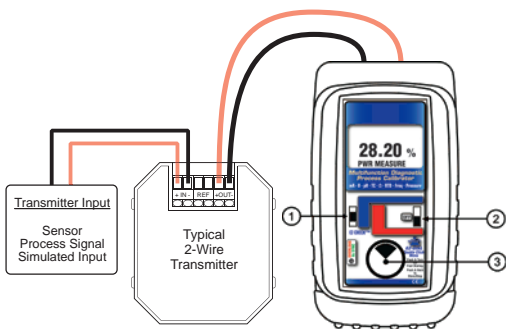

Using Ground Leak Detection

mA OUT, % OUT (Percent of 4 to 20 mA)

Find current leaks in loops caused by ground faults, moisture or corrosion. The 820-ELITE simultaneously supplies power to a 2 Wire Transmitter (or loop with a transmitter) while displaying the 4 to 20 mA output and the amount of current leaking in the loop.

- 1) Move the power switch ② to READ then Double Click the EZ-DIAL knob to get into the Double Click Menu. Turn the knob ③ to scroll through the settings and press the knob to make your selection. Select mA for the FUNCTION and PWRM LEAK for the MODE. Choose either mA or %.
- 2) Connect the red source lead from the mA (+) jack of the 820-ELITE to the plus (+) input of the device and the black source lead from the mA (-) to the minus (-).

The PIE 820-ELITE supplies a nominal 24 volts DC at 24 mA to the 2 Wire Transmitter or loop. The current passed by the transmitter will be accurately displayed by the 820-ELITE along with an indication of leakage current at the top of the display. If there is an uncontrolled loop, a transmitter with upscale burnout and bad or missing sensor or a short the display shows "OVER RANGE"

Note: Many installed transmitters will normally indicate 0.01 to 0.02 mA leakage without significant control problem. Unstable readings may indicate loose connections or the presence of moisture.

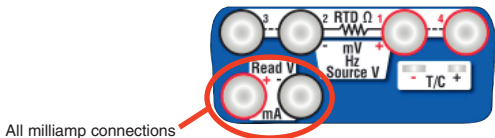

mV/V SOURCE

Choose this function to provide an output from -20.000 to 99.999 mV, -500.00 TO 999.99 mV or from 0.000 to 10.250 V. The source current is a nominal 24 mA to provide the driving power to your voltage receivers.

Move the power switch ② to SOURCE then Double Click the EZ-DIAL knob to get into the Double Click Menu. Turn the knob to scroll through the settings and press the knob to make your selection. Select V for the FUNCTION and 10V or 80 mV for the RANGE.

Connect the output leads of the PIE 820-ELITE to the inputs of the device being calibrated, making sure to check polarity. Red lead to the plus (+) input and black lead to the minus (-) input.

Instantly output your SPAN and ZERO output settings by moving the EZ-CHECK switch between HI and LO. You may also select any third output setting (such as mid-range) using the SET position on the EZ-CHECK switch. The output is adjusted in 0.001 mV, 0.01 mV or 0.001 V increments by turning the knob ③. Press and turn the knob for faster dialing with 0.100 mV, 1.00 mV or 0.100 V increments.

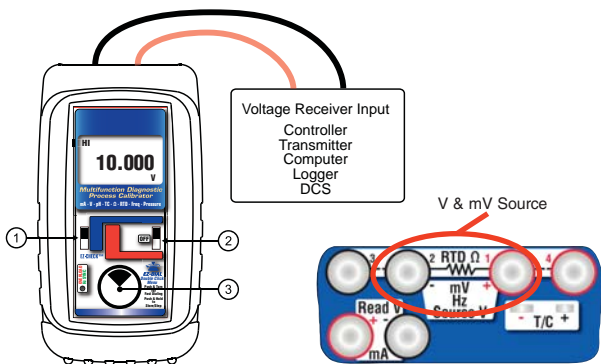

Read mV/V

Choose this function to measure from -99.999 to 99.999 millivolts, -99.999 to +99.999 mV, 0.000 to 10.250 V dc or 0.00 to 60.00 V dc.

Move the power switch ② to READ then Double Click the EZ-DIAL knob to get into the Double Click Menu. Turn the knob to scroll through the settings and press the knob to make your selection. Select V for the FUNCTION and 10V, 1V, 60V or 100 mV for the RANGE.

Connect the red input lead (+) of the PIE 820-ELITE to the more positive point of the break and the black input to the more negative point.

Signals above the maximum scale are limited by protection circuitry with "OVERRANGE" flashed on the display and the red OVERLOAD LED lit.

The PIE 820-ELITE measures the input signal and constantly updates the display with the current reading. Move the EZ-CHECK switch ① to MAX to see the highest reading and to MIN to see the lowest reading. Press and hold the knob ③ to clear the MAX and MIN readings.

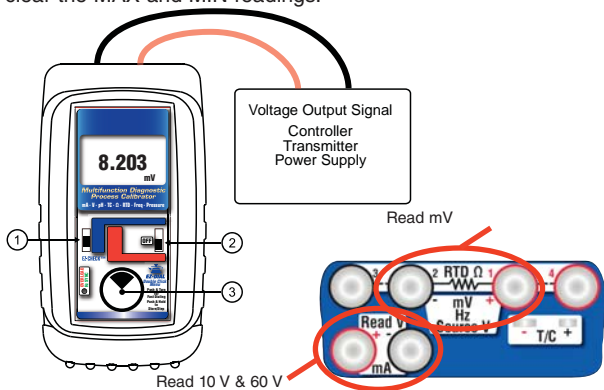

pH SOURCE

Choose this function to provide an output from 0.000 to 14.000 pH @ 25°C (77°F) which corresponds to 414.12 to -414.12 mV. The source current is a nominal 24 mA to provide the driving power to your pH receivers.

Move the power switch ② to SOURCE then Double Click the EZ-DIAL knob to get into the Double Click Menu. Turn the knob to scroll through the settings and press the knob to make your selection. Select pH for the FUNCTION.

Connect the output leads of the PIE 820-ELITE to the inputs of the device being calibrated, making sure to check polarity. Red lead from the mV (+) jack of the 820-ELITE to the plus (+) input and black lead from the mV (-) jack to the minus (-) input. You may also use the optional adaptor jack (020-0###) if you require BNC connections.

Instantly output your SPAN and ZERO output settings by moving the EZ-CHECK switch between HI and LO. You may also select any third output setting (such as mid-range) using the DIAL position on the EZ-CHECK switch. The output is adjusted in 0.001 pH increments by turning the knob ③. Press and turn the knob for faster dialing with 0.100 pH increments.

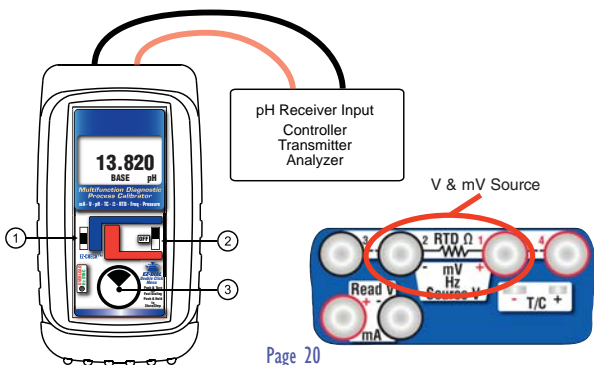

Simulate pH probes into transmitters & analyzers

Use the pH simulator to verify proper operation of pH devices before you place a probe into a calibrated buffer. Adjusting the pH transmitter or analyzer without a probe allows you to make sure the device is calibrated and operating correctly. The 820-ELITE simulates 0.000 to 14.000 pH @ 25°C corresponding to 414.12 to -414.12 mV.

Once the pH instrument has been adjusted against the PIE 820-ELITE reconnect the pH probe and check it against the proper buffer (typically 7 pH). If the instrument zero point requires more than the manufacturer's recommendations (typically within 0.5 pH) it is time to clean or replace the probe.



Thermocouple Source

Choose this function to provide a simulated thermocouple signal into controllers, temperature transmitters, indicators or any input devices that measure thermocouple sensors.

Move the power switch ② to SOURCE then Double Click the EZ-DIAL knob to get into the Double Click Menu. Turn the knob to scroll through the settings and press the knob to make your selection. Select T/C for the FUNCTION, °F or °C for the UNITS, T/C Type (J, K, T, E, R, S, B, N, G, C, D, L (J-DIN), U (T-DIN) or P (Platinel II) and internal COLD JUNC ON or OFF (ON is the default).

Connect the PIE 820-ELITE to the inputs of the device being calibrated using the proper type of thermocouple wire via the miniature thermocouple socket.

Instantly output your SPAN and ZERO output settings by moving the EZ-CHECK switch between HI and LO. You may also select any third output setting (such as mid-range) using the SET position on the EZ-CHECK switch. The output is adjusted in 0.1° increments by turning the knob ③. Press and turn the knob for faster dialing with 10.0° increments.

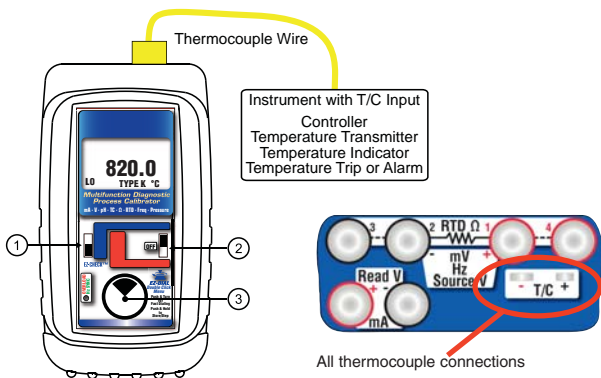

Read Thermocouple Sensors

Choose this function to measure temperatures with a thermocouple probe or sensor.

Move the power switch ② to READ then Double Click the EZ-DIAL knob to get into the Double Click Menu. Turn the knob to scroll through the settings and press the knob to make your selection. Select T/C for the FUNCTION, °F or °C for the UNITS, T/C Type (J, K, T, E, R, S, B, N, G, C, D, L (J-DIN), U (T-DIN) or P (Platinel II) and COLD JUNC ON or OFF (ON is the default).

Connect the PIE 820-ELITE to the inputs of the device being calibrated using the proper type of thermocouple wire via the miniature thermocouple socket. If no sensor is connected, a wire is broken or the sensor is burned out, OPEN TC will appear on the display. Signals above the maximum scale are limited by protection circuitry with "OVERRANGE" on the display and the red OVERLOAD LED lit.

The PIE 820-ELITE measures the input signal and constantly updates the display with the current reading. Move the EZ-CHECK switch ① to MAX to see the highest reading and to MIN to see the lowest reading. Press and hold the knob ③ to clear the MAX and MIN readings.

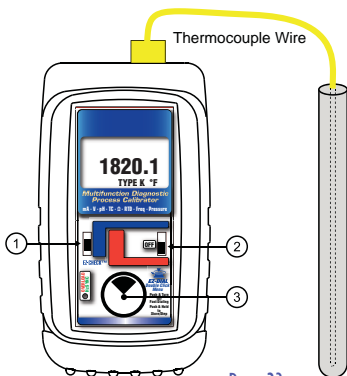

Resistance Source

Choose this function to provide a simulated resistance into any device that measures resistance.

Move the power switch ② to SOURCE then Double Click the EZ-DIAL knob to get into the Double Click Menu. Turn the knob to scroll through the settings and press the knob to make your selection. Select OHMS for the FUNCTION, 400Ω or 4000Ω for the RANGE.

Disconnect all sensor wires from the devices to be calibrated and connect the PIE 820-ELITE to the inputs of the device using 2, 3 or 4 wires.

Instantly output your SPAN and ZERO output settings by moving the EZ-CHECK switch between HI and LO. You may also select any third output setting (such as mid-range) using the SET position on the EZ-CHECK switch. The output is adjusted in 0.01Ω/0.1Ω increments by turning the knob ③. Press and turn the knob for faster dialing with 1.00Ω/10.0Ω increments.

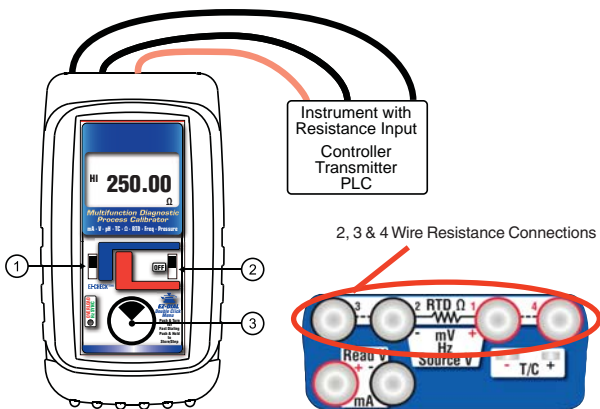

Read Resistance & Check Continuity

Choose this function to measure resistance or check continuity.

Move the power switch ② to READ then Double Click the EZ-DIAL knob to get into the Double Click Menu. Turn the knob to scroll through the settings and press the knob to make your selection. Select OHMS for the FUNCTION, 400 Ω , 4000 Ω or Continuity for the RANGE. You must also select the WIRE MODE for 2W, 3W or 4W to match the 2, 3 or 4 wires being used to measure resistance. For continuity the only choice is 2W.

Disconnect all wires from the sensor and connect the PIE 820-ELITE to the inputs of the device using 2, 3 or 4 wires.

If continuity is selected, resistance is measured up to 400.0 Ω . The beeper will sound and))) appears on the display when resistance and below 100.0 Ω is measured.

Signals above the maximum scale are limited by protection circuitry with "OVERRANGE" flashed on the display and the red OVERLOAD LED lit.

The PIE 820-ELITE measures the input signal and constantly updates the display with the current reading. Move the EZ-CHECK switch ① to MAX to see the highest reading and to MIN to see the lowest reading. Press and hold the knob ③ to clear the MAX and MIN readings.

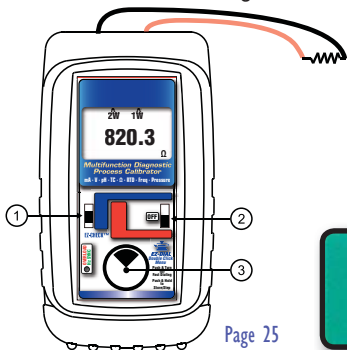

RTD Source

Choose this function to provide a simulated RTD signal into controllers, temperature transmitters, indicators or any input devices that measure RTD sensors.

Move the power switch ② to SOURCE then Double Click the EZ-DIAL knob to get into the Double Click Menu. Turn the knob to scroll through the settings and press the knob to make your selection. Select RTD for the FUNCTION, °F or °C for the UNITS and RTD (Choose from one of Platinum 100Ω, or 1000Ω, Copper 10Ω or 50Ω, Nickel 120Ω or 110Ω curves). *Note: Pt 100Ω 3850 is the most common RTD type.*

Disconnect all sensor wires from the devices to be calibrated and connect the PIE 820-ELITE to the inputs of the device using 2, 3 or 4 wires.

Instantly output your SPAN and ZERO output settings by moving the EZ-CHECK switch between HI and LO. You may also select any third output setting (such as mid-range) using the SET position on the EZ-CHECK switch. The output is adjusted in 0.1° increments by turning the knob ③. Press and turn the knob for faster dialing with 10.0° increments.

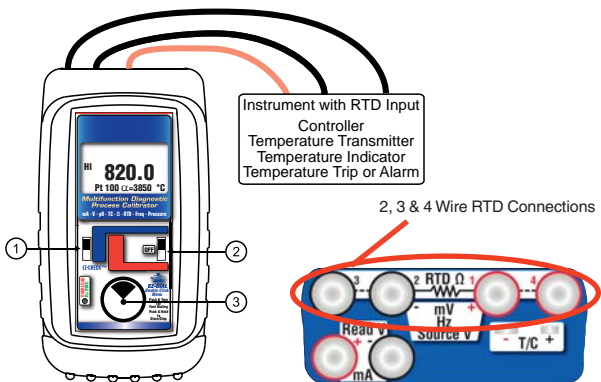

Read RTD Sensors

Choose this function to measure temperatures with an RTD probe or sensor.

Move the power switch ② to READ then Double Click the EZ-DIAL knob to get into the Double Click Menu. Turn the knob to scroll through the settings and press the knob to make your selection. Select RTD for the FUNCTION, °F or °C for the UNITS and RTD (Choose from one of Platinum 100 Ω , or 1000 Ω , Copper 10 Ω or 50 Ω , Nickel 120 Ω or 110 Ω curves). *Note: Pt 100 Ω 3850 is the most common RTD type.* You must also select the WIRE MODE for 2W, 3W or 4W to match the 2, 3 or 4 wires on the RTD sensor.

Disconnect all wires from the sensor and connect the PIE 820-ELITE to the inputs of the device using 2, 3 or 4 wires.

Signals above the maximum scale are limited by protection circuitry with "OVERRANGE" flashed on the display and the red OVERLOAD LED lit.

The PIE 820-ELITE measures the input signal and constantly updates the display with the current reading. Move the EZ-CHECK switch ① to MAX to see the highest reading and to MIN to see the lowest reading. Press and hold the knob ③ to clear the MAX and MIN readings.

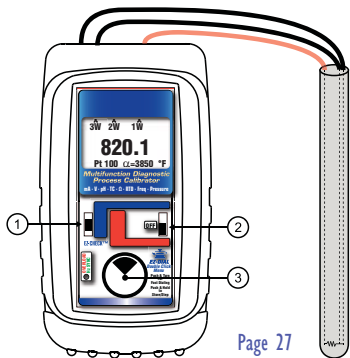

Frequency Source

Choose this function to provide a frequency signal into any input devices that measure frequency.

Move the power switch ② to SOURCE then Double Click the EZ-DIAL knob to get into the Double Click Menu. Turn the knob to scroll through the settings and press the knob to make your selection. Select **FREQ** for the **FUNCTION** and **20KHZ**, **10000HZ**, **1000HZ** or **2000CPM** for the **RANGE**.

Disconnect all input wires from the devices to be calibrated and connect the PIE 820-ELITE to the input of the device matching polarity.

The green HZ SYNC LED pulses in synch with the output pulses and may be used to calibrate optical pickups. The output signal is a zero crossing square wave with a fixed amplitude of 6 V peak-to-peak from -1 and + 5 V.

Instantly output your SPAN and ZERO output settings by moving the EZ-CHECK switch between HI and LO. You may also select any third output setting (such as mid-range) using the SET position on the EZ-CHECK switch. The output is adjusted in 1 count increments by turning the knob ③. Press and turn the knob for faster dialing with 100 count increments.

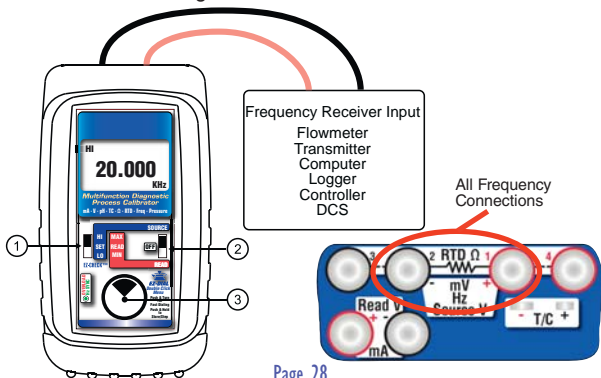

Read Frequency

Choose this function to count frequency.

Move the power switch ② to READ then Double Click the EZ-DIAL knob to get into the Double Click Menu. Turn the knob to scroll through the settings and press the knob to make your selection. Select FREQ for the FUNCTION and 20KHZ, 10000HZ, 1000HZ or 2000CPM for the RANGE.

Disconnect all input wires from the devices to be calibrated and connect the PIE 820-ELITE to the output of the device matching polarity.

The green HZ SYNC LED pulses in synch with the input frequency.

Signals above the maximum scale are limited by protection circuitry with "OVERRANGE" flashed on the display and the red OVERLOAD LED lit.

The PIE 820-ELITE measures the input signal and constantly updates the display with the current reading. Move the EZ-CHECK switch ① to MAX to see the highest reading and to MIN to see the lowest reading. Press and hold the knob ③ to clear the MAX and MIN readings.

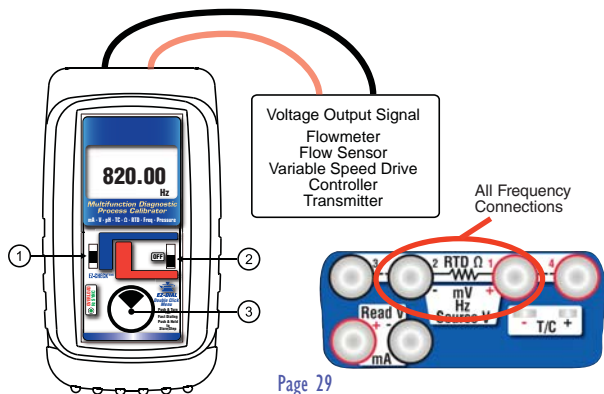

Read Pressure

Choose this function to measure pressure in one of 15 different engineering units using a Crystal Multical Pressure Module.

1) Move the power switch ② to READ then Double Click the EZ-DIAL knob to get into the Double Click Menu. Turn the knob to scroll through the settings and press the knob to make your selection. Select PRESSURE for the FUNCTION and make your choice of UNITS to match the pressure instrument to be checked.

The following screen will appear each time pressure is selected to remind you that the switch on the Multical Pressure Module MUST be set to PSI for the PIE 820-ELITE to indicate the correct pressure. *Failure to do so will result in the wrong pressure being indicated and possible damage to the pressure module.*

**PLUG IN MODULE
SWITCH TO PSI
PRESS
E-Z DIAL KNOB
TO CONTINUE**

2) Connect the electrical output of the pressure module to the mV inputs of the PIE 820-ELITE matching polarity.

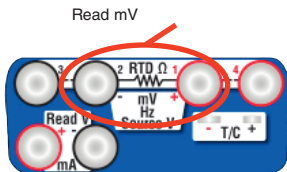

Read Pressure

3) Connect pressure hoses, fittings & pumps (if required) to the pressure instrument to be checked.

4) Move the switch on the Pressure Module to PSI and press the E-Z Dial knob on the 820-ELITE.

5) Press and hold the ③ E-Z DIAL KNOB for 1 second to 'Zero' the pressure. The word "TARE" appears on the display indicating that all measurements are relative to the pressure measured when the calibrator was zeroed.

Pressure readings appear on the display of the 820-ELITE and are constantly updated.

The PIE 820-ELITE measures the pressure and constantly updates the display with the current reading. Move the EZ-CHECK switch ① to MAX to see the highest reading and to MIN to see the lowest reading. Press and hold the knob ③ for 2 seconds to clear the MAX and MIN readings.

30 psi/2 bar Gauge & Absolute Modules	
Units	Maximum
PSI	30.000
Inches H2O@4°C	830.40
Inches H2O@20°C	831.90
Inches H2O@60°F	831.22
Inches HG@0°C	61.080
bar	2.0684
mbar	2068.4
kPa	206.84
MPa	0.2068
Kgf/CM2	2.1092
cm H2O@4°C	2109.2
cm H2O@23°C	2114.4
mm H2O@4°C	21092
mm H2O@23°C	21144
mm Hg @ 0°C	1551.4

500 psi/35 bar Gauge Modules	
Units	Maximum
PSI	500.00
Inches H2O@4°C	999.99*
Inches H2O@20°C	999.99*
Inches H2O@60°F	999.99*
Inches HG@0°C	1018.0
bar	34.474
mbar	34474
kPa	3447.4
MPa	3.4474
Kgf/CM2	35.153
cm H2O@4°C	35153
cm H2O@23°C	35240
mm H2O@4°C	99999*
mm H2O@23°C	99999*
mm Hg @ 0°C	25857

Specifications

General	
Operating Temp Range	-20 to 60 °C (-5 to 140 °F)
Storage Temp Range	-30 to 60 °C (-22 to 140 °F)
Temperature effect	$\leq \pm 0.005 \text{ \%}/^{\circ}\text{C}$ of Full Scale
Relative Humidity Range	10 % \leq RH \leq 90 % (0 to 35 °C), Non-condensing
	10 % \leq RH \leq 70 % (35 to 60 °C), Non-condensing
Normal Mode Rejection	50/60 Hz, 50 dB
Common Mode Rejection	50/60 Hz, 120 dB
Noise	$\leq \pm \frac{1}{2}$ Least Significant Digit from 0.1 to 10 Hz
Size	5.63x3.00x1.60" 143x76x41mm (LxWxH)
Weight	12.1 ounces, 0.34 kg with boot & batteries
Batteries	Four "AA" Alkaline 1.5V (LR6)
Battery life	Read Functions: ≥ 20 hours Source mA: ≥ 14 hours @ 12 mA into 250 Ω Pwr/Meas mA: ≥ 12 hours at 20 mA Source V, Ω , T/C, RTD & Hz: ≥ 20 hours
Low Battery	Low battery indication with nominal 1 hour of operation left
Protection against misconnection	Over-voltage protection to 60 vrms (rated for 30 seconds) Red LED indicates OVERLOAD or out of range conditions
Display	High contrast graphic liquid crystal display with 0.315" (8.0 mm) high digits. LED backlighting.

Specifications

Read mA	
Ranges and Resolution	0.000 to 24.000 mA or -25.00 to 125.00% of 4-20 mA
Accuracy	$\leq \pm (0.02 \% \text{ of Reading} + 0.003 \text{ mA})$
Voltage burden	$\leq 2\text{V}$ at 24 mA
Overload/Current limit protection	25 mA nominal

Source mA / Power & Measure Two Wire Transmitters	
Ranges and Resolution	0.000 to 24.000 mA or -25.00 to 125.00% of 4-20 mA
Accuracy	$\leq \pm (0.02 \% \text{ of Reading} + 0.003 \text{ mA})$
Loop compliance voltage	$\geq 24 \text{ DCV @ } 20.00\text{mA}$
Loop drive capability	1200 Ω at 20 mA for 15 hours nominal; 950 Ω with Hart Resistor or leak detection running

mA 2-Wire Transmitter Simulation	
Accuracy	Same as Source/Power & Measure
Voltage burden	$\leq 2\text{V}$ at 20 mA
Overload/mA protection	24 mA nominal
Loop voltage limits	2 to 60 VDC (fuse-less protected from reverse polarity connections)

DC Voltage Read	
Range and Resolution	$\pm 99.999 \text{ mV}$, $\pm 999.99\text{mV}$, 0 to 10.250 V, 0.00 to 60.00 V DC
Accuracy	$\leq \pm (0.02 \% \text{ of Reading} + 0.01\% \text{ Full Scale})$
Input resistance	$\geq 1 \text{ M}\Omega$

Specifications

Source V dc	
Ranges and Resolution	-20.000 to 99.999 mV, -500.00 to 999.99 mV, 0.000 to 10.250V
Accuracy	$\leq \pm (0.02 \% \text{ of Reading} + 0.01\% \text{ Full Scale})$
Source Current	$\geq 24 \text{ mA}$
Sink Current	$> 16 \text{ mA}$
Output Impedance	$< 1 \text{ Ohm}$
Short Circuit Duration	Infinite

pH Source	
Range and Resolution	0.000 to 14.000 pH
Accuracy in mV	$\leq \pm (0.02 \% \text{ of Reading in mV} + 0.1 \text{ mV})$
Accuracy in pH	$\leq \pm 0.003 \text{ pH @ } 25^{\circ}\text{C}$

Thermocouple Source	
Accuracy	$\leq \pm (0.02 \% \text{ of Reading} + 0.01 \text{ mV})$
Cold Junction Compensation	$\pm (0.1^{\circ}\text{C} + 0.01\%/^{\circ}\text{C})$
Output Impedance	$< 1 \text{ Ohm}$
Source Current	$> 20 \text{ mA}$ (drives 80 mV into 10 Ohms)

Thermocouple Read	
Accuracy & Cold Junction Compensation	Same as Thermocouple Source
Input Impedance	$> 1 \text{ Megohms}$
Open TC Threshold; Pulse	10K Ohms; $< 5 \mu\text{amp}$ pulse for 300 milliseconds (nominal)

Specifications

RTD, OHMS and Continuity Read	
Resistance Ranges	0.00 to 401.00, 0.0 to 4010.0 Ohms
Accuracy	$\pm(0.02\%$ of Reading + 0.075 Ohms)
Excitation Current	1.0 mA to 401 Ohms, 0.6 mA to 4010 Ohms (nominal)
Continuity	0.0 to 401.0 Ohms; Beeps from 0.0 to 100.0 Ohms

RTD and OHMS Source	
3 Wire & 4 Wire Accuracy	
From 1 to 10.2 mA External Excitation Current	$\pm(0.03\%$ of Full Scale + 0.075 Ohms)
Below 1 mA of External Excitation Current	$\pm(0.03\%$ of Full Scale + 0.075 Ohms + $\frac{0.025 \text{ mV}}{\text{mA Excitation Current}}$)
2 Wire Accuracy	Add 0.1 Ohm to specifications listed above
Resistance Ranges	0.0 to 410.00, 0.0 to 4010.0 Ohms
Allowable Excitation Current Range	<401 Ohms: 10.2 mA max; steady or pulsed/intermittent 401 to 4010 Ohms: 1 mA max; steady or pulsed/intermittent
Pulsed Excitation Current Compatibility	DC to 0.01 second pulse width

Specifications

Frequency Source	
Ranges	1 to 2000 CPM, 0.01 to 999.99 Hz, 0.1 to 9999.9 Hz, 0.001 to 20.000 kHz
Accuracy	$\leq \pm (0.02 \% \text{ of Reading} + 0.01\% \text{ Full Scale})$
Output Waveform	Square Wave, Zero Crossing -1.0 to +5 V peak-to-peak $\pm 10\%$
Risetime (10 to 90% of amplitude)	< 10 microseconds
Output Impedance	< 1 Ohm
Source Current	> 1 mA rms at 20 kHz
Short Circuit Duration	Infinite
Optical Coupling	Green LED (HZ SYNC) flashes at output frequency

Frequency Read	
Ranges & Accuracy	Same as Frequency Source
Accuracy	$\leq \pm (0.02 \% \text{ of Reading} + 0.01\% \text{ Full Scale})$
Trigger Level	1 V rms, dc coupled
Input Impedance	> 1 Meg Ohm + 60 pF

Thermocouple Ranges & Accuracies

Based on $\pm(0.03\%$ of 80 mV)

T/C	Degrees C Range	°C	Degrees F Range	°F
J	-200.0 to -50.0	$\pm 0.5^\circ$	-328.0 to -58.0	$\pm 1.0^\circ$
	-50.0 to 300.0	$\pm 0.2^\circ$	-58.0 to 572.0	$\pm 0.4^\circ$
	300.0 to 900.0	$\pm 0.3^\circ$	572.0 to 1652.0	$\pm 0.6^\circ$
	900.0 to 1200.0	$\pm 0.4^\circ$	1652.0 to 2192.0	$\pm 0.8^\circ$
K	-230.0 to -50.0	$\pm 1.2^\circ$	-382.0 to -58.0	$\pm 2.2^\circ$
	-50.0 to 550.0	$\pm 0.3^\circ$	-58.0 to 1022.0	$\pm 0.6^\circ$
	550.0 to 1000.0	$\pm 0.5^\circ$	1022.0 to 1832.0	$\pm 0.8^\circ$
	1000.0 to 1371.1	$\pm 0.6^\circ$	1832.0 to 2500.0	$\pm 1.1^\circ$
T	-260.0 to -230.0	$\pm 2.9^\circ$	-436.0 to -382.0	$\pm 5.2^\circ$
	-230.0 to -210.0	$\pm 1.0^\circ$	-382.0 to -346.0	$\pm 1.9^\circ$
	-210.0 to -50.0	$\pm 0.8^\circ$	-346.0 to -58.0	$\pm 1.4^\circ$
	-58.0 to 50.0	$\pm 0.3^\circ$	-58.0 to 122.0	$\pm 0.6^\circ$
	50.0 to 400.0	$\pm 0.2^\circ$	122.0 to 752.0	$\pm 0.4^\circ$
E	-240.0 to -200.0	$\pm 0.9^\circ$	-400.0 to -328.0	$\pm 1.7^\circ$
	-200.0 to 0.0	$\pm 0.5^\circ$	-328.0 to 32.0	$\pm 0.8^\circ$
	0.0 to 350.0	$\pm 0.2^\circ$	32.0 to 662.0	$\pm 0.3^\circ$
	350.0 to 1000.0	$\pm 0.3^\circ$	662.0 to 1832.0	$\pm 0.6^\circ$
R	-18.3 to 100.0	$\pm 2.1^\circ$	-1.0 to 212.0	$\pm 3.8^\circ$
	100.0 to 500.0	$\pm 1.3^\circ$	212.0 to 932.0	$\pm 2.4^\circ$
	500.0 to 1400.0	$\pm 1.0^\circ$	932.0 to 2552.0	$\pm 1.8^\circ$
	1400.0 to 1767.8	$\pm 1.2^\circ$	2552.0 to 3214.0	$\pm 2.0^\circ$

Thermocouple Ranges & Accuracies

Based on $\leq \pm (0.02 \% \text{ of Reading} + 0.01 \text{ mV})$

T/C	Degrees C Range	°C	Degrees F Range	°F
S	-18.3 to 100.0	$\pm 2.0^\circ$	-1.0 to 212.0	$\pm 3.7^\circ$
	100.0 to 350.0	$\pm 1.4^\circ$	212.0 to 662.0	$\pm 2.5^\circ$
	350.0 to 1600.0	$\pm 1.1^\circ$	662.0 to 2912.0	$\pm 2.0^\circ$
	1600.0 to 1767.8	$\pm 1.3^\circ$	2912.0 to 3214.0	$\pm 2.4^\circ$
B	315.6 to 600.0	$\pm 3.2^\circ$	600.0 to 1122.0	$\pm 5.7^\circ$
	600.0 to 850.0	$\pm 1.7^\circ$	1122.0 to 1562.0	$\pm 3.1^\circ$
	850.0 to 1100.0	$\pm 1.3^\circ$	1562.0 to 2012.0	$\pm 2.4^\circ$
	1100.0 to 1820.0	$\pm 1.1^\circ$	2012.0 to 3308.0	$\pm 2.0^\circ$
N	-230.0 to -150.0	$\pm 1.9^\circ$	-382.0 to -238.0	$\pm 3.4^\circ$
	-150.0 to -50.0	$\pm 0.7^\circ$	-238.0 to -58.0	$\pm 1.2^\circ$
	-50.0 to 950.0	$\pm 0.4^\circ$	-58.0 to 1742.0	$\pm 0.8^\circ$
	950.0 to 1300.0	$\pm 0.5^\circ$	1742.0 to 2372.0	$\pm 1.0^\circ$
G (W)	100.0 to 350.0	$\pm 1.7^\circ$	212.0 to 662.0	$\pm 3.0^\circ$
	350.0 to 1700.0	$\pm 0.8^\circ$	662.0 to 3092.0	$\pm 1.5^\circ$
	1700.0 to 2000.0	$\pm 1.0^\circ$	3092.0 to 3632.0	$\pm 1.8^\circ$
	2000.0 to 2320.0	$\pm 1.1^\circ$	3632.0 to 4208.0	$\pm 2.1^\circ$
C (W5)	-1.1 to 100.0	$\pm 0.8^\circ$	30.1 to 212.0	$\pm 1.4^\circ$
	100.0 to 1000.0	$\pm 0.7^\circ$	212.0 to 1832.0	$\pm 1.3^\circ$
	1000.0 to 1750.0	$\pm 1.2^\circ$	1832.0 to 3182.0	$\pm 2.1^\circ$
	1750.0 to 2320.0	$\pm 2.0^\circ$	3182.0 to 4208.0	$\pm 3.5^\circ$

Thermocouple Ranges & Accuracies

Based on $\leq \pm (0.02 \% \text{ of Reading} + 0.01 \text{ mV})$

T/C	Degrees C Range	°C	Degrees F Range	°F
D	-1.1 to 150.0	$\pm 1.0^\circ$	30.1 to 302.0	$\pm 1.8^\circ$
	150.0 to 1100.0	$\pm 0.7^\circ$	302.0 to 2012.0	$\pm 1.3^\circ$
	1100.0 to 1750.0	$\pm 1.0^\circ$	2012.0 to 3182.0	$\pm 1.8^\circ$
	1750.0 to 2320.0	$\pm 2.0^\circ$	3182.0 to 4208.0	$\pm 3.6^\circ$
P	0.0 to 600.0	$\pm 0.3^\circ$	32.0 to 1112.0	$\pm 0.6^\circ$
	600.0 to 900.0	$\pm 0.4^\circ$	1112.0 to 1652.0	$\pm 0.8^\circ$
	900.0 to 1200.0	$\pm 0.6^\circ$	1652.0 to 2192.0	$\pm 1.1^\circ$
	1200.0 to 1395.0	$\pm 0.7^\circ$	2192.0 to 2543.0	$\pm 1.2^\circ$
L J-DIN	-200.0 to -50.0	$\pm 0.4^\circ$	-328.0 to -58.0	$\pm 0.7^\circ$
	-50.0 to 300.0	$\pm 0.2^\circ$	-58.0 to 572.0	$\pm 0.4^\circ$
	300.0 to 900.0	$\pm 0.3^\circ$	572.0 to 1652.0	$\pm 0.5^\circ$
U T-DIN	-200.0 to -50.0	$\pm 0.6^\circ$	-328.0 to -58.0	$\pm 1.1^\circ$
	-50.0 to 50.0	$\pm 0.3^\circ$	-58.0 to 122.0	$\pm 0.5^\circ$
	50.0 to 550.0	$\pm 0.2^\circ$	122.0 to 1022.0	$\pm 0.4^\circ$
	550.0 to 600.0	$\pm 0.3^\circ$	1022.0 to 1112.0	$\pm 0.5^\circ$

RTD Ranges & Accuracies

RTD Accuracy Based on $\pm(0.03\%$ of Reading in Ohms + 0.075 Ohms)

RTD Type	Degrees C Range	°C	Degrees F Range	°F
Pt 100 Ohm DIN/IEC/JIS 1989 1.3850 (ITS-90)	-200.0 to 0.0	$\pm 0.2^\circ$	-328.0 to 32.0	$\pm 0.4^\circ$
	0.0 to 340.0	$\pm 0.3^\circ$	248.0 to 644.0	$\pm 0.6^\circ$
	340.0 to 640.0	$\pm 0.4^\circ$	644.0 to 1184.0	$\pm 0.8^\circ$
	640.0 to 850.0	$\pm 0.5^\circ$	1184.0 to 1562.0	$\pm 1.0^\circ$
Pt 100 Ohm (Burns) 1.3902	-200.0 to 10.0	$\pm 0.2^\circ$	-328.0 to 50.0	$\pm 0.4^\circ$
	10.0 to 350.0	$\pm 0.3^\circ$	50.0 to 662.0	$\pm 0.6^\circ$
	350.0 to 650.0	$\pm 0.4^\circ$	662.0 to 1202.0	$\pm 0.8^\circ$
	650.0 to 850.0	$\pm 0.5^\circ$	1202.0 to 1562.0	$\pm 0.9^\circ$
Pt 100 Ohm (Old JIS 1981) 1.3916	-200.0 to 20.0	$\pm 0.2^\circ$	-328.0 to 68.0	$\pm 0.4^\circ$
	20.0 to 360.0	$\pm 0.3^\circ$	68.0 to 680.0	$\pm 0.6^\circ$
	360.0 to 650.0	$\pm 0.4^\circ$	680.0 to 1202.0	$\pm 0.8^\circ$
	650.0 to 850.0	$\pm 0.5^\circ$	1202.0 to 1562.0	$\pm 0.9^\circ$
Pt 100 Ohm (US Lab) 1.3926	-200.0 to 20.0	$\pm 0.2^\circ$	-328.0 to 68.0	$\pm 0.4^\circ$
	20.0 to 360.0	$\pm 0.3^\circ$	68.0 to 680.0	$\pm 0.6^\circ$
	360.0 to 660.0	$\pm 0.4^\circ$	680.0 to 1220.0	$\pm 0.8^\circ$
	660.0 to 850.0	$\pm 0.5^\circ$	1220.0 to 1562.0	$\pm 0.9^\circ$
Pt 1000 Ohm DIN/IEC/JIS 1989 1.3850	-200.0 to 0.0	$\pm 0.2^\circ$	-328.0 to 32.0	$\pm 0.4^\circ$
	0.0 to 340.0	$\pm 0.3^\circ$	248.0 to 644.0	$\pm 0.6^\circ$
	340.0 to 640.0	$\pm 0.4^\circ$	644.0 to 1184.0	$\pm 0.8^\circ$
	640.0 to 850.0	$\pm 0.5^\circ$	1184.0 to 1562.0	$\pm 1.0^\circ$
Copper 10 Ohm 1.4274 (Minco)	-200.0 to 260.0	$\pm 2.0^\circ$	-328.0 to 500.0	$\pm 3.6^\circ$
Copper 50 1.4280	-50.0 to 150.0	$\pm 0.4^\circ$	-58.0 to 302.0	$\pm 0.8^\circ$
Ni 120 Ohm 1.6720 (Pure)	-80.0 to 260.0	$\pm 0.1^\circ$	-112.0 to 500.0	$\pm 0.3^\circ$
Ni 110 Ohm Bristol 7 NA 1.5801	-100.0 to 260.0	$\pm 0.2^\circ$	-148.0 to 500.0	$\pm 0.4^\circ$

Standard Warranty

Our equipment is warranted against defective material and workmanship (excluding batteries) for a period of three years from the date of shipment. Claims under warranty can be made by returning the equipment prepaid to our factory. The equipment will be repaired, replaced or adjusted at our option. The liability of Practical Instrument Electronics (PIE) is restricted to that given under our warranty. No responsibility is accepted for damage, loss or other expense incurred through sale or use of our equipment. Under no condition shall Practical Instrument Electronics, Inc. be liable for any special, incidental or consequential damage.

Optional Repair/Replacement Warranty

Under our Repair/Replacement Warranty (RP-WAR-B), our equipment is warranted against ANY damage or malfunction that may cause the unit to fail for a period of three (3) years from the date of shipment.

This warranty is limited to one complete replacement against any damage or malfunction during the warranty period. If replaced, the new calibrator will carry our Standard Warranty for the remainder of the three (3) years or a minimum of one (1) year from the date of shipment.

Additional Information

PIE Calibrators are manufactured in the USA. This product is calibrated on equipment traceable to NIST and includes a Certificate of Calibration. Test Data is available for an additional charge.

Practical Instrument Electronics recommends a calibration interval of one year. Contact your local representative for recalibration and repair services.