

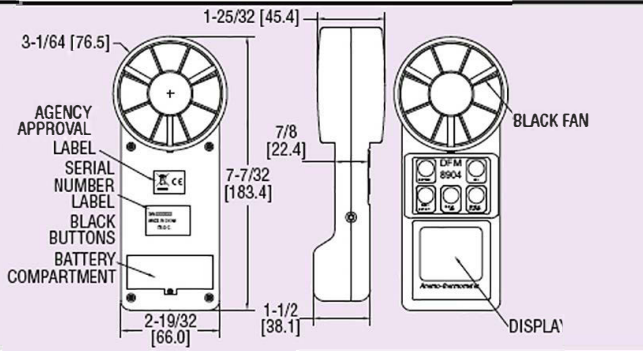

Model  
8904

# Integral Vane Thermo-Anemometer

## Large 1.3" Dual Display, One Hand Operation



Simultaneously measure air velocity and temperature with the Model 8904 Integral Vane Thermo-Anemometer. The large 1.3" (34 mm) display allows users to easily view readings. User-selectable wind speed units include ft/min, m/sec, knots, mph and km/hr. Additionally, a built-in sensor records ambient temperature in °F or °C. Model 8904 features include data hold, the ability to record minimum, maximum and average readings on a single point and an RS-232 interface setting. The units can also record and average up to 2 hours of data while displaying the continuous running average. Model 8904 includes hard carrying case, battery and instruction manual. This compact meter is ideal for HVAC inspection, energy audits and balancing applications.

### APPLICATIONS

This meter is most ideal for measuring heat, ventilation, air conditioning, refrigerating wind flow and temperature.

Model 8904, Integral Vane Thermo-Anemometer

### SPECIFICATIONS

#### AIR VELOCITY

Range: 80 to 5900 ft/min (0.4 to 30 m/s).  
Accuracy:  $\pm 2\%$  of reading  $\pm 0.2$  m/s.  
Resolution: 1 ft/min (0.01 m/s).  
Response Time: 1 second.

#### TEMPERATURE

Range: 14 to 122°F (-10 to 50°C).  
Accuracy:  $\pm 1^\circ\text{F}$  ( $\pm 0.6^\circ\text{C}$ ).  
Resolution: 0.1°F/°C.  
Response Time: 60 seconds.

### ACCESSORY

A-552, USB Cable and RS-232 Software

### METER

Display: 1.3 x 1.6" (34 x 40 mm).  
Serial Communications: 2400 bps, 8 data bits.  
Power Requirements: 9 V alkaline battery, included, user replaceable.  
Battery Life: 100 hours.  
Vane Diameter: 2-7/8" (70 mm).  
Weight: 5.3 oz (150 g).  
Agency Approvals: CE.