

920 Roll Groover

The RIDGID 920 Roll Groover takes grooving to a whole new level. With a capacity range of 2" – 24" diameter pipe, the 920 has the largest capacity of any RIDGID roll groover. The 920 mounts to the RIDGID 300 Power Drive for use in the field or shop. Also available is the new RJ624 Large Diameter Pipe Support for grooving pipe up to 24" in diameter, a perfect complement to the 920 Roll Groover.

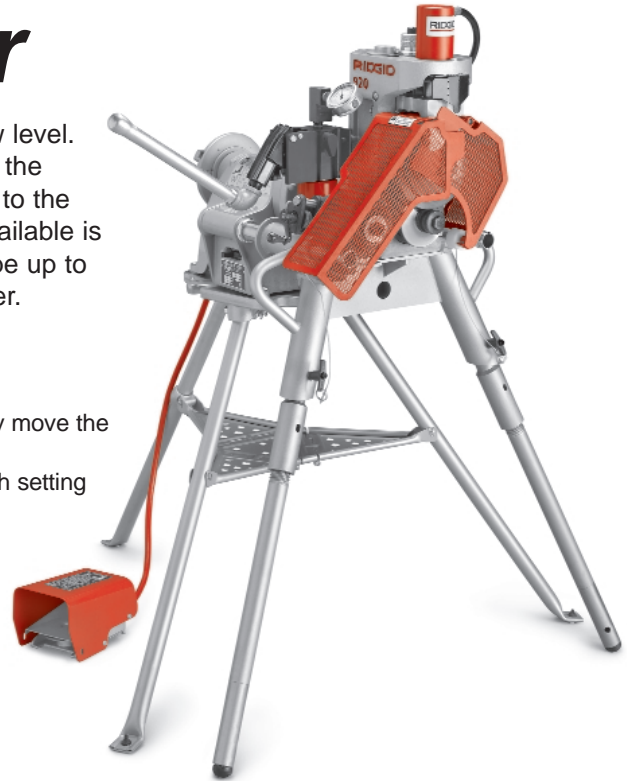

920 Benefits:

1. Largest Grooving Capacity In Its Class – (Refer to chart below.)
2. Transportation Mode – Detachable Wheels: One man can easily move the 920 around a job site
3. Patented Depth Setting Gage – Easy and accurate groove depth setting
4. Built-in Pressure Gage – Helps operator monitor hydraulic pressure to control flare and optimize groove time
5. Front Roll Set Change-out – User can switch groove roll sets quickly and easily
6. Easy Adjust Support Legs – Helpful when leveling the groover on uneven ground

Standard Equipment:

- 920 Roll Groover with support legs
- 2" – 6" Sch. 10/40 Groove Roll Set with box
- 8" – 12" Sch. 10/40 Groove Roll Set
- 14" – 16" Standard Wall (0.375) Groove Roll Set with box
- #32 Transporter
- 920 Training Video and User Manual



Capacity:

Material	Pipe Size/Schedule													
	2	2½	3	3½	4	4½	5	6	8	10	12	14	16	18 – 24
Steel					Sch. 5, 10, 40							5, 10, std.*		.250
Stainless					Sch. 5, 10, 40							5, 10, std.*		.250
Aluminum					Sch. 5, 10, 40							5, 10, std.*		.250
PVC	40		40, 80							40				
Copper	K,L	K,L,M			K, L, M & DWV									

* Std. = Standard wall thickness (0.375)

Catalog No.	Model No.	Description	Weight lb.	Weight kg.
95782	920	920 Roll Groover with 2" – 6" Sch. 40, 8" – 12" Sch. 40 and 14" – 16" Std. Wall Roll Sets	199	90,3
96987	–	Drive and Groove Roll Set for 18" – 20" Sch. 10 Steel or Stainless Steel	21	9,5
96992	–	Drive and Groove Roll Set for 22" – 24" Sch. 10 Steel or Stainless Steel	22	10
96997	–	Drive and Groove Roll Set for 4" – 6" Sch. 40 Steel or Stainless Steel	20	9
96982	–	Drive and Groove Roll Set for 2" – 8" Copper Tube Type K, L, M, and DWV	20	9
96372	RJ624	RJ624 Large Diameter Pipe Stand	167	75,7
76827	–	Metric Diameter Tape	0.3	0,14
76822	–	English Diameter Tape	0.3	0,14
42575	32	Transporter	14.25	6,5