

EDSYN INC

971 LONER[®]

high performance

Temperature Controlled
Soldering Station

SPECIFICATIONS

- 120V, 50/60Hz, 70W, 2.5 lbs. (1.13 kg.)
- COMPLIES WITH DOD-STD-2000-1B, MIL-STD-2000A and ESD SPEC. DOD-STD 1868, DOD-HDBK-263
- TEMP. RANGE: 400°F - 800°F (205°C - 427°C)
- TEMP. REGULATION: ±6°F (±3°C)
- TIP TO GROUND LEAKAGE: < 2MV
- TIP TO GROUND RESISTANCE: < 2 OHMS
- UL LISTED

made
in
USA

Static Safe

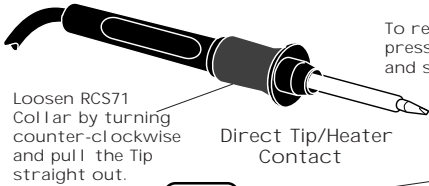

Loosen RCS71 Collar by turning counter-clockwise and pull the Tip straight out.

Direct Tip/Heater Contact

To replace Pod, press Release Tab and slide out Pod.

PD528 Tool Pod



Temp. Regulation Indicator



Temp. Control



Sponge Holder



Power Switch

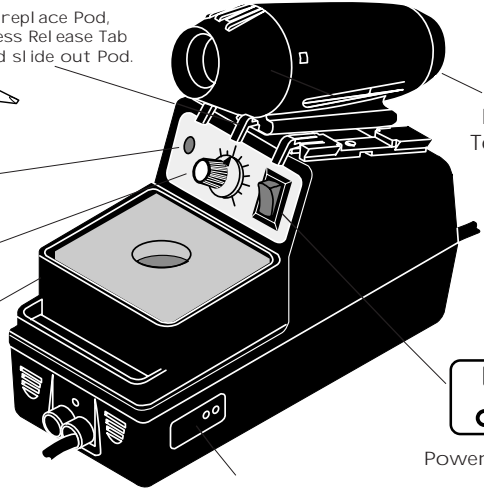

Hi/Lo Temp. Calibration Pot

TIP CARE

1. Set desired temperature. Blinking Lamp means Tool is regulating.
2. TIN the Tip. (apply solder)
3. Do not rub, bend or reshape the Tip.
4. Always clean the Tip by wiping it against the saturated sponge and always RE-TIN.

WARNING: DO NOT HIT OR TAP THE TOOL. HEATER ELEMENT WILL BREAK!!!

TEMPERATURE CALIBRATION

AIR MOVEMENT WILL AFFECT THE TEMPERATURE READING.
WORK IN AN AREA WHERE THIS IS MINIMAL.

1. Turn on power and set Temperature Control Knob to 400°F.
2. Using a clean and well tinned Tip, apply a small amount of solder on the Tip, just enough to form a bead on top of the Tip.
3. Place the center of the thermocouple wire of the SDS100 on top of the bead.
4. Again, apply a small amount of solder on the center of the thermo-couple wire, just enough to embed the center.
5. Adjust LO-Temp. Calibration Pot so the Meter will read 400°F.
6. Set Temperature Control Knob to 800°F.
7. Adjust Hi-Temp. Calibration Pot so the Meter will read 800°F.

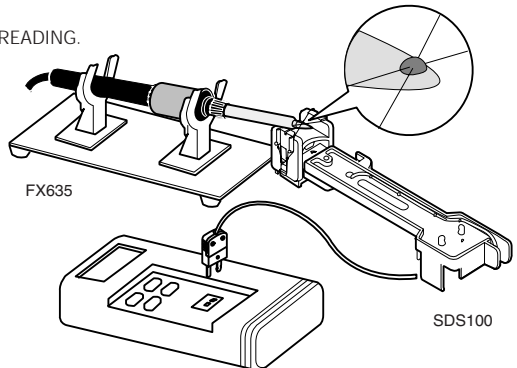

MS412
Temperature
Calibration System

971 LONER[®] High Performance SOLDERING STATION SPARE PARTS LIST

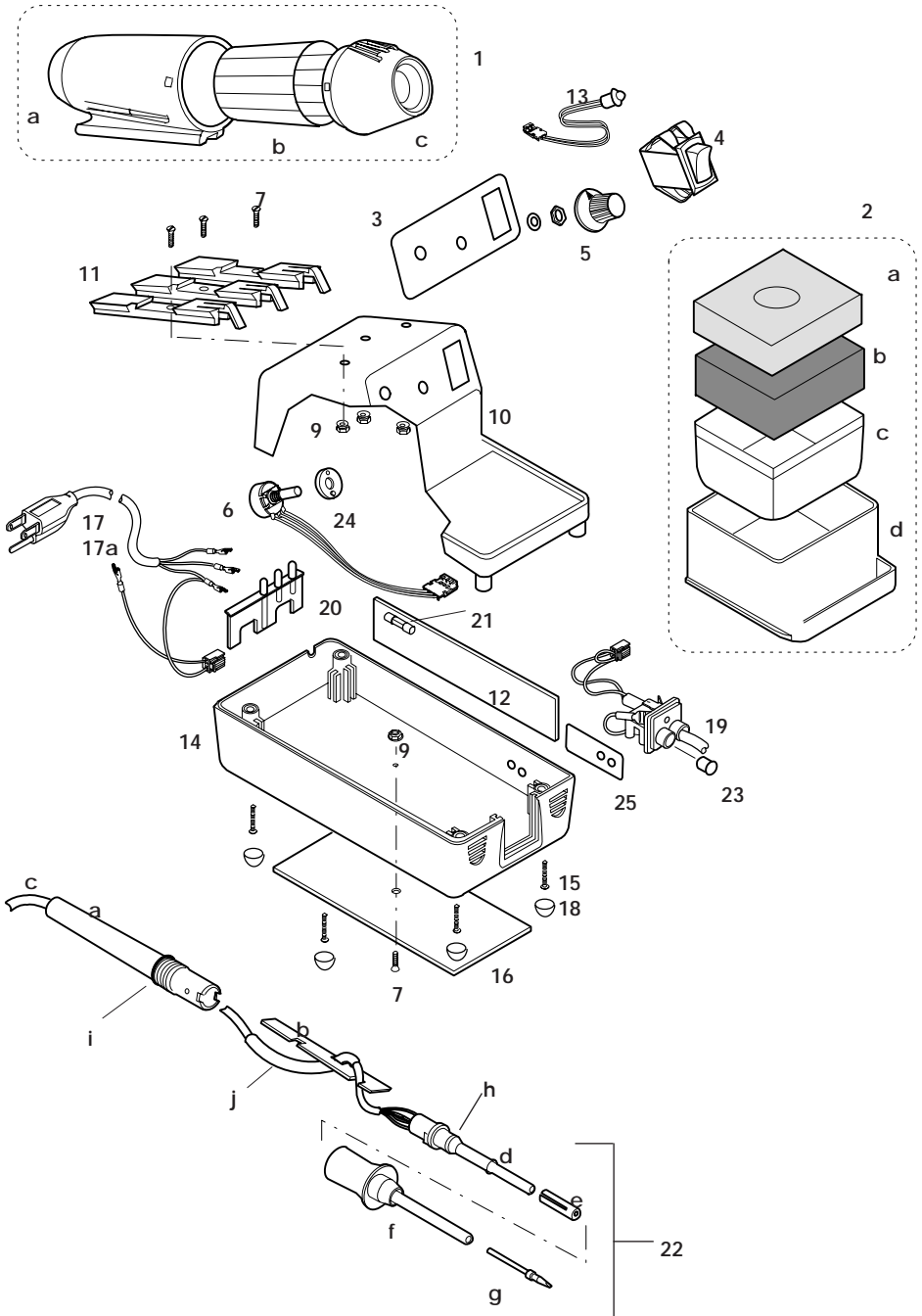

ITEM NO.	PART NO.	DESCRIPTION	QTY REQ'D
1	PD528	Tool Pod	1
1a	SR042	Thermal Housing for Tool Pod	1
1b	SC581	Solder Collector for Tool Pod	1
1c	SR043	Front Housing for Tool Pod	1
2	SH230	General Purpose Sponge Holder	1
2a	RS199	Cleaning Sponge	1
2b	RS243	Leveling Pad for SH230	1
2c	LN230	Liner for SH230	1
2d	SH230-1	Sponge Holder Tray	1
3	SR577	Control Panel Label	1
4	SR065	Power Switch, Illuminated	1
5	SR045	Knob, Temperature Control	1
6	SR243	5K Potentiometer, Temperature Control	1
7	SR015	Flat Head Screw- Slotted #6 - 32 x 1/2	4
9	SR467	Hex Nut, Square Cone- #6 - 32	4
10	SR741	Top Base	1
11	SR019	Dove Tail Mount	1
12	15002W95	Circuit Board	1
13	SR573	LED Assy. Front Panel Mount	1
14	SR611	Bottom Base	1
15	SR011	Pan Head Screw- Phillips #6 - 18 x 5/8	4
16	SR054	Bottom Weight	1
17	SR252	Power Cord Assy.	1
17a	SR026	Power Cord only (connectors not included)	1
18	SR251	Rubber Foot	4
19	SR226	Strain Relief Block for Tool Cord (Power Cord Assy. not included)	1
20	SR241	Strain Relief for Power Cord	1
21	SR249	Fuse, 250V, 1.6 A (5mm x 20 mm)	1
22	SR575	Soldering Tool, Complete Assembly	1
22a	SR579	Handle for Tool	1
22b	SR058	Cord Strain Relief	1
22c	SR280	Tool Cord, Burn Proof Connector Assy. on one end)	1
22d	SR574	Heater Assembly	1
22e	LTC71	Tip Collet	1
22f	RCS71	Retaining Collar and Sleeve	1
22g	LT375	LONER [®] Standard Spade Tip	1
22h	SR001	O-Ring, Silicone, .30 ID	1
22i	SR240	O-Ring, For Handle, .50 ID	1
22j	SR525	Hose, Low Static, 1/4 I.D. (1/8" per foot)	51/4"
23	SR301	Plug, Covering for Strain Relief, Tool Cord Outlet	1
24	SR255	Spacer for Potentiometer	1
25	SR310	Label, Set Pot, Right Front or Left Rear	

REPLACING TIPS

CAUTION

1. Tool must be cool when changing tips.
2. Do not twist or wiggle the tip.

AFTER TIP IS INSTALLED, TIGHTEN COLLAR PROPERLY.

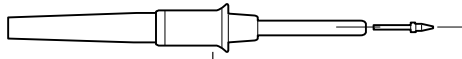

- Loosen RCS71 Collar by turning counter-clockwise and pull the Tip straight out.

General Purpose Soldering Tips

Iron Plated for Long Life-Nickel and Chrome Plated for optimum heat transfer.

EDSYN has over a 100 varieties of standard and custom-made Tips. CONTACT EDSYN FOR MORE SELECTIONS.

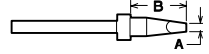

	Part No. & Description	a	b
	LT374 Standard Probe	.03 (0.8 mm)	.48 (12.2 mm)
	LT375 Standard Spade	.06 (1.5 mm)	.48 (12.2 mm)
	LT376-7 SMD Channel	.12 (3.0 mm)	.48 (12.2 mm)
	LT392 Extra-Long Needle	.02 (0.5 mm)	1.13 (28.8 mm)
	LT394 Extra-Long Spade	.07 (2.0 mm)	.93 (23.6 mm)
	LT399 Large Face	.17 (4.3 mm)	.49 (12.4 mm)
	LT444 SMD Mid-Length Fine Spade	.04 (1.0 mm)	.78 (19.8 mm)
	LT446 SMD Probe	.03 (0.8 mm)	.48 (12.2 mm)
	LT382 Long Cone	.02 (0.5 mm)	.62 (15.6 mm)
	LT395 Mid-Length Stubby Spade	.09 (2.3 mm)	.74 (18.8 mm)
	LT431 Mid-Length Spade	.07 (1.8 mm)	.74 (18.8 mm)
	LT439 SMD Thin Probe	.03 (0.8 mm)	.50 (12.7 mm)
	LT439-1 Same as LT439, Angled		
	LT445 SMD Angle Face	.03 (0.8 mm)	.48 (12.2 mm)



MAINTENANCE

• Replace RS199 Cleaning Sponge

1. Fill water only up to the top RS243 level in Pad.
2. Depress RS199 to moisten it completely.

• Replace SC581 Solder Collector

1. Hold the Housing Firm and turn Cap counter-clockwise and pull it away from the Housing.
2. Remove used SC581 and replace with a new one.
3. Reassemble Pod with TOP of the Cap in proper position.

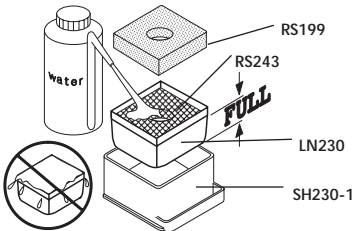

CAUTION:
Over-filling can cause thermal shock to the tip or heating element during tip cleaning.

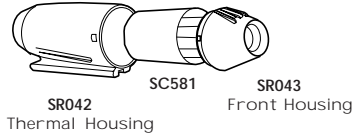

Test Equipment Depot

99 Washington St. Melrose MA, 02176
1.800.517.8431 | 781.665.0780 (Fax)