

Test Equipment Depot

99 Washington St. Melrose MA, 02176

1.800.517.8431 | 781.665.0780 (Fax)

Instructions
for

EDSYN^{INC}®

971HAe

LONER® ATMOSCOPE®



Product Features

- Our newest compact hot air station provides versatile and outstanding performance using hot air or contact rework methods from one handle (requires shop air or nitrogen 20-80 psi)
- New smaller footprint features an illuminated, compact design with precise temperature control
- Adjustable airflow provides precise application of hot air and automatic shut off valve turns air off when hand-piece is placed back in holder
- Uses a wide variety of nozzle sizes
- Accepts a wide variety of tips
- Easy to maintain and calibrate with an 18 month warranty
- ESD safe
- UL listed

Package Contents

971HAe SMT Hot Air Station with
LT428 Nozzle

PD533 Tool Pod

SH235 Modular Sponge Tray with RS200
Round Cleaning Sponge

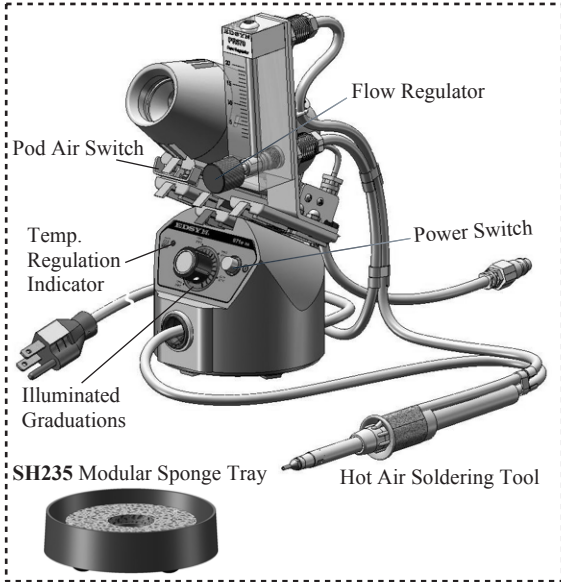

Front Right Side View

PR570 Flow Regulator

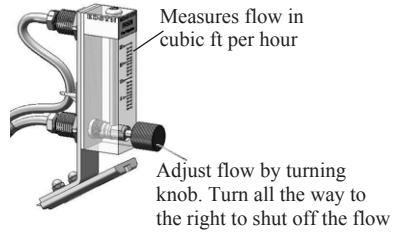

PAS53 Pod Air Switch

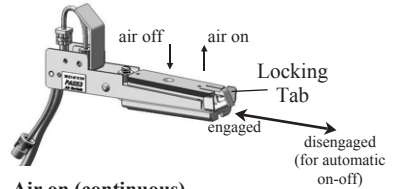

Air on (continuous)
With tool out of the pod, push in on Tab to lock.

Air off (continuous)
With tool in the pod, push in on Tab to lock.

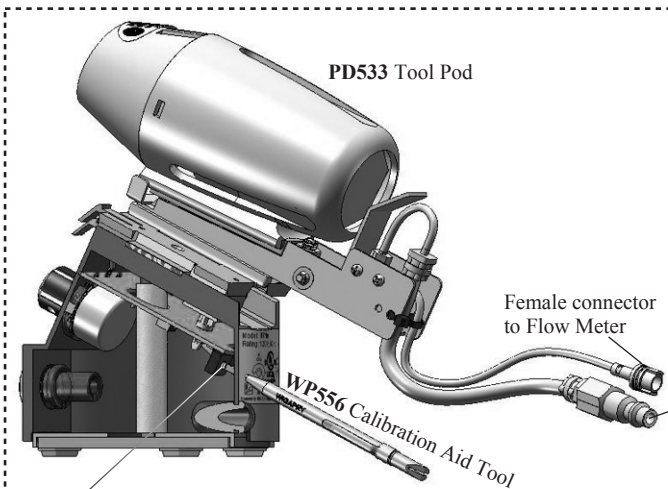

Rear Side Section View

Calibration Pots for HI & LO Temp.

CAUTION: HOT AIR WILL BURN! Place tool in Pod when not in use.

Reworking SMDs

IMPORTANT factors involved when working with the ATMOSCOPE SMT Hot Air Tool

1. Amount of air output.
2. Temperature setting.
3. Type of tip used.

The key to an effective soldering is to reflow the solder without blowing the solder across the board and creating bridges.

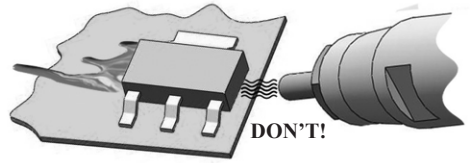

The following techniques are based on the manufacturer's point of view and should only serve as guidelines. Its effectiveness will depend on practice.

For Resistors, Capacitors, Transistors, and Alike

1. Have the proper Tip installed.
2. Adjust air output to about 2-4 scfh.
3. Set temperature between 700°F to 800°F.
4. Heat up the joints until the solder melts.
5. Remove by using a pair of tweezers.
6. To resolder, hold SMD in place making sure leads are aligned with solder pads.
7. Direct hot air flow to the connection until solder reflows. Release SMD when solder solidifies.

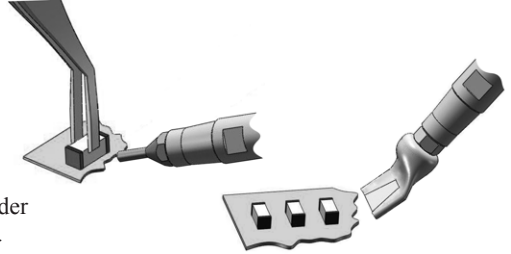

For Gullwings, Leadless Chip Carriers, and Quad I.Cs

Method 1

1. Have the proper Tip installed.
2. Adjust air output to about 2-4 scfh.
3. Set temperature to 700°F.
4. Using a **WS630** SMD Pull Wire, thread the pullwire under the leads of one side of the SMD and again thread the wire under the leads of the opposite side.
5. Anchor one end of the Pull Wire to an unused hole of the circuit board or maybe tape it securely to the board.
6. While directing hot air to the leads of the first side, pull the wire so that it will cut through the solder connection.
7. After removing the two opposing sides, follow the same procedure to desolder the remaining sides.
8. To resolder, use a tweezer to hold SMD in place and align the leads with the pads.
9. Use a Fan Tip whose width is as close to the size of the SMD leads as possible.
10. Direct hot air on the leads and allow solder to reflow. Release SMD when solder solidifies.

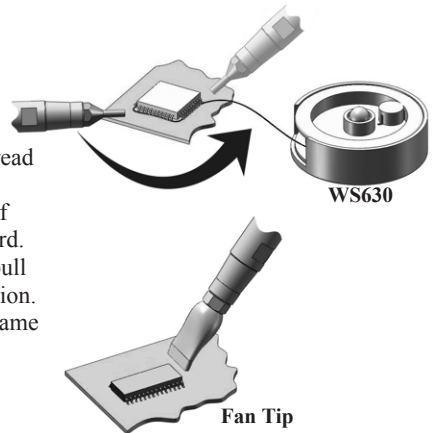

Method 2

1. Have the proper Tip installed.
2. Adjust air output to about 2-4 scfh.
3. Set temperature between 700°F to 800°F.
4. Heat up one corner of the SMD.
5. When the solder melts, insert the shimblade of the **ST706** SMD Helper under the heated area of the chip as if cutting through the solder connection.
6. While directing hot air ahead of the shim at all times, cut through the sides of the SMD and lift up from the board.
7. To resolder use a Quadra-Flow Tip.

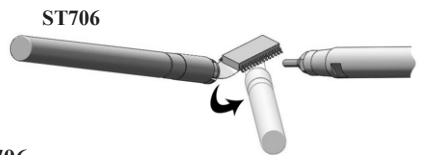

SMT Hot Air Tips

More Tips are available at our website (www.edsyn.com) or in our General Line Catalog.

Technique	Suggested Hot Air Tips for Technique	Description	Hole Dia.	Length	Width
For Resistors Capacitors or Transistors	LT427	LONER SMT Nozzle Hot Air Tip (Jet Tip for pin point air flow)	.02" (0.5mm)	.38" (95mm)	_____
OR	LT432	LONER SMT Nozzle Hot Air Tip (Short Jet Tip for medium air flow)	.04" (1.0mm)	.06" (1.5mm)	_____
Method 2	LT428	LONER SMT Nozzle Hot Air Tip (Turbo flow for large air flow)	.06" (1.5mm)	.25" (6.4mm)	_____
Method 1	LT426	LONER SMT Fan Hot Air Tip (Fan Tips provide a wide air flow to cover one whole side of the SMD)	_____	.17" (4.3mm)	.30" (7.6mm)
	LT435		_____	.59" (15.0mm)	.35" (8.9mm)
	LT436		_____	.65" (16.5mm)	.43" (10.9mm)
For Resistors Capacitors or Transistors	LT526	LONER SMT Fan Hot Air Tip (Dual Flow Tips blow air on both sides of the SMD, not on the SMD)	.03" (0.8mm)	.12" (3.0mm)	.30" (7.6mm)
OR	LT534		.05" (1.3mm)	.20" (5.1mm)	.46" (11.7mm)
Method 1	LT536			.35" (8.9mm)	.65" (16.5mm)

OPTIONAL:

Apply **AN112** Anti-Seize Compound or **AN122** High Heat Anti-Seize Syringe Dispenser to heater or area of tip contact.



AN112



AN122

Using Quadra-Flow Tips (Recommended for Four Side Leaded Components)

Quadra-Flow Tips come in a variety of sizes. Increase air output as you increase the size of the Tip.

1. Place Quadra-Flow Tips over the SMD.
2. After waiting for the solder to melt, twist tool gently to see if the SMD is free.
3. Remove SMD by using a pair of tweezers.
4. To resolder, glue SMD to the board with the leads aligned with the pads.
5. Place Quadra-Flow Tip over SMD and allow solder to reflow

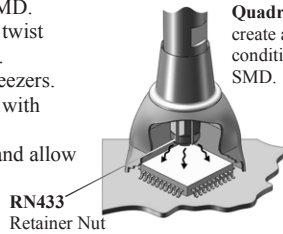



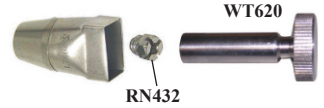

Quadra-Flow Tips create an "oven like" condition around the SMD.

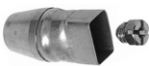

Use WT620 Socket Wrench to install Tips with RN432 or RN433 Retaining Nut

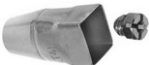

SMT Hot Air Quadra-Flow Tips

Part No. and Description	Width	Length	Package
 LT449 LONER SMD Quadra-Flow Hot Air Tip	.26" (6.6mm)	.41" (10.4mm)	SO-16
 LT478* LONER SMD Quadra-Flow Hot Air Tip	.32" (8.1mm)	.45" (11.4mm)	LCCC-18R
 LT462* LONER SMD Quadra-Flow Hot Air Tip	.34" (8.6mm)	.55" (14.0mm)	PLCC-18
 LT451* LONER SMD Quadra-Flow Hot Air Tip	.44" (11.2mm)	.48" (12.2mm)	SO-18L
 LT468** LONER SMD Quadra-Flow Hot Air Tip	.66" (16.8mm)	.90" (22.9mm)	QFP-100
 LT477** LONER SMD Quadra-Flow Hot Air Tip	.77" (19mm)	1.0" (25.4mm)	_____

* Comes with RN432 Retaining Nut for Small Quadra-Flow Tips

** Comes with RN433 Retaining Nut for Large Quadra-Flow Tips

Bendable Hot Air Tips

 LT571* LONER SMD Bendable Hot Air Tip	 LT572* LONER SMD Bendable Hot Air Tip
--	--

* Includes WT624 Tip Wrench



Using the WT624 these Tips can be bent to accommodate most SMD sizes

Changing Tips

1. Turn Tip counter-clockwise by using a **WT620** Socket Wrench.
2. Remove and replace with desired Tip.

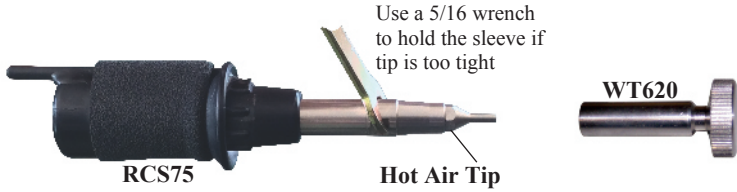

Hot Air Calibration

It is highly recommended to use new or very clean thermocouple wires.

FOLLOW SET-UP AS ILLUSTRATED

1. With the Hot Air Tip inside the **TPL09-1** Ceramic Temperature Sensor, place the center of the thermocouple wire of the **SDS100** Temperature Sensor Dock inside the slot of the **TPL09-1**.
2. Push the power switch and set the Temperature Control Knob to 400°F.
3. Turn Flow Regulator Knob to 4 - 5 SCFH.
4. Adjust LO-Temp. Calibration Pot so the Meter will read 400°F.
5. Set Temperature Control Knob to 800°F.
6. Adjust Hi-Temp Calibration Pot so the Meter will read 800°F.

MS412

Digital Temperature Measurement System



For a quicker calibration for more than one station try using the **TP475** Temperature Probe



971HAe Exploded View

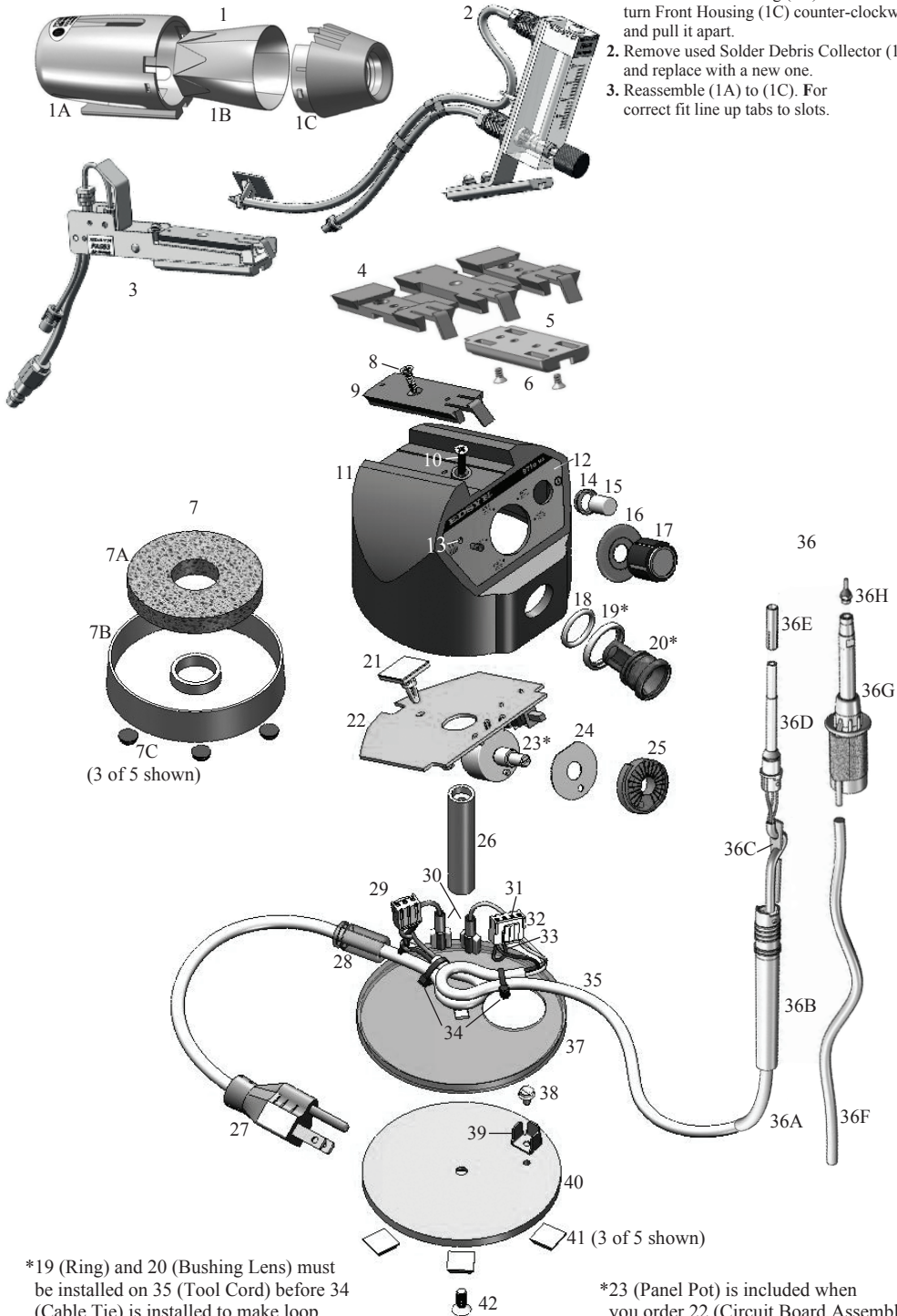

Tool Pod Maintenance

Replace SC581 Solder Collector

1. Hold Thermal Housing (1A) firm and turn Front Housing (1C) counter-clockwise and pull it apart.
2. Remove used Solder Debris Collector (1B) and replace with a new one.
3. Reassemble (1A) to (1C). For correct fit line up tabs to slots.

*19 (Ring) and 20 (Bushing Lens) must be installed on 35 (Tool Cord) before 34 (Cable Tie) is installed to make loop.

*23 (Panel Pot) is included when you order 22 (Circuit Board Assembly)

971HAe Spare Parts List

ITEM NO.	PART NO.	DESCRIPTION	QTY. NEEDED
1	PD533	Tool Pod (includes SC581)	1
1A	SR042	Thermal Housing for Tool Pod	1
1B	SC581	Solder Debris Collector	1
1C	SR457	Front Housing for Tool Pod	1
2	PR570	Air Flow Regulator	1
3	PAS53	Tool Pod Air Switch	1
4	SR019	Dove Tail Mount	1
5	SR553	Single Mount for Dovetail	1
6	SR1601	Philips Flat Head Screw	2
7	SH235	Modular Sponge Tray Holder (includes RS200 round cleaning sponge)	1
7A	RS200	Round Cleaning Sponge	1
7B	SR1225	Sponge Tray	1
7C	SR251	Rubber Feet (Set of 4)	1.25 set
8	SR367	Phillips Flat Head Screw	1
9	SR784	Single Dovetail Track	1
10	SR772	Phillips Flat Head Screw	1
11	SR1200	Housing for Soldering Station	1
12	SR1201	Front Panel Label	1
13	SR1226	Front Panel Mount Light Pipe	1
14	SR1202	Switch Button Lens Ring	1
15	SR1203	Round Chrome Switch Cap	1
16	SR1205	Dial Face Lens Cover	1
17	SR1204	Black Control Knob	1
18	SR1208	Silicone O-Ring	1
19	SR1207	Ring for Tool Cord Bushing Lens	1
20	SR1206	Tool Cord Bushing Lens	1
21	SR1224	Locking PCB Support	1
22	SR1223	Circuit Board Assembly	1
23*	SR1211	5K Wire-Wound Panel Pot	1
24	SR1210	Background Washer for Dial Face	1
25	SR1209	Dial Face Lens	1
26	SR1212	Base Post Enclosure	1

* Included when ordering circuit board assembly

971HAe
Spare Parts List Cont'd.

ITEM NO.	PART NO.	DESCRIPTION	QTY NEEDED
27	SR1221	Power Cord Assembly	1
28	SR1222	Power Cord Bushing Lens	1
29	SR432	3 Circuit Housing Connector (Set of 3)	.3 set
30	SR495	Female Fully Insulated Connector (Set of 5)	.4 set
31	SR415	Terminal Crimp (Set of 10)	.3 set
32	SR1213	Insulated Display Housing Connector	1
33	SR445	Black Wire	.16ft
34	SR1214	Cable Tie	2
35	SR059	Tool Cord	1
36*	SR620	Hot Air Soldering Tool, Complete Assembly	1
36A	SR525	Static-Safe Silicone Black Hose	.43ft
36B	SR579	Handle	1
36C	SR058	Strain Relief	1
36D	SR574	High Performance Hollow Heater Assembly (includes Shrink Sleeving)	1
36E	LTC71	Tip Collet	1
36F	HS307	Static-Safe Silicone Black Hose	5ft
36G	RCS75	Retaining Collar and Sleeve for Hot Air	1
36H	LT428	SMT Nozzle Hot Air Tip	1
37	SR1216	Clear Lens Base Cover	1
38	SR1217	Hex Screw	1
39	SR1220	3 Terminal Ground Lug	1
40	SR1218	Metal Base	1
41	SR242	Square Rubber Feet (Set of 4)	1.25 set
42	SR1219	Flat Head Screw	1

* Also included are items 35,34,33,32,31,20,19, and 18.

Specifications

Power Requirements	120V, 60Hz
Power Rating	15W - 220W
Heater Rating	120V, 95W
Temperature Range	400°F-800°F/205°C-427°C
Temperature Regulations	±6°F/±3°C
Tip-to-Ground Voltage	
Leakage/Resistance	< 2mV/< 2 ohms
Overall Dimension	4.5" W x 9" H x 6.75" D 114 mm x 228mm x 171 mm
Weight	3lbs (1.4 kg)

Warranty

Edsyn stands behind its products. We warranty that new tools will be free from defects for 18 months from the date of purchase. During this time period Edsyn will repair or, at its option, replace the tool at no charge. This warranty does not include tips and accessories. Any tool that appears to have been deliberately abused, altered, or destroyed is not covered by this warranty.

Technical Support

Contact our Customer Service for assistance related to the purchase of this product or recommendations on a challenge that you may encounter. There are many replacement parts that are available to keep your tool in top condition. To speak to someone in Customer Service, call 818-989-2324.

©Copyright 2015 by EDSYN®, Inc. All Rights Reserved

No part of this publication, including individual icons, may be reproduced or utilized in any form or by any means without the written permission of EDSYN®, Inc.



Designed Patented & Assembled in U.S.A.



Design, color, weight, and material subject to change without notice. Components from other designs may be used with information pertaining to it, but not applicable to another use.

Labels and instructions will supersede this information.



Test Equipment Depot

99 Washington St. Melrose MA, 02176

1.800.517.8431 | 781.665.0780 (Fax)

© Visit us at www.TestEquipmentDepot.com

Form. 971HAe