

BK PRECISION®

Test Equipment Depot - 800.517.8431 - 99 Washington Street Melrose, MA 02176
TestEquipmentDepot.com

Model: 9801

Programmable AC Power Source

PROGRAMMING MANUAL



Table of Contents

1	Remote Operation	4
1.1	Interface Connection.....	4
	<i>RS-232</i>	4
	<i>USBTMC</i>	4
2	Remote Commands	5
2.1	Parameter Definitions.....	5
2.2	IEEE488.2 Common Commands.....	5
2.3	STATUS Subsystem.....	8
2.4	SYSTEM Subsystem.....	12
2.5	TRIGGER Subsystem.....	15
2.6	SOURCE Subsystem.....	15
2.7	CONFIG Commands.....	16
2.8	MEASURE and FETCH Commands.....	19
2.9	LIST Commands.....	22
2.10	SWEEP Commands.....	25

Test Equipment Depot - 800.517.8431 - 99 Washington Street Melrose, MA 02176

TestEquipmentDepot.com

1 Remote Operation

1.1 Interface Connection

RS-232

For RS-232 connectivity, refer to the diagram below for pin out information. The RS-232 is labeled in the rear panel and it is a female DB-9 interface.

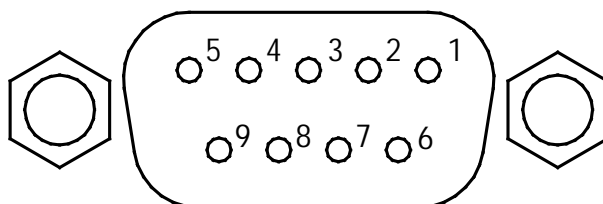

PIN	Description
1	-
2	Transmit Data
3	Receive Data
4	-
5	GND
6	-
7	-
8	-
9	-

A straight pin-to-pin DB9 female to DB9 male serial cable is required for using the RS-232 interface. Do not use a null modem or crossover DB9 serial cable.

Refer to the user manual for details on configuring all serial settings as required for RS-232 communication.

USBTMC

The standard USB port is a USBTMC-compliant port that can be used for remote communication. There are no settings in the menu system for USB configuration. The only requirement is that NI-VISA is installed on the computer, which can be downloaded at <http://www.ni.com/visa/>.

2 Remote Commands

2.1 Parameter Definitions

The 9800 Series power supplies support communication protocols, which include standard SCPI commands and a few proprietary commands that follow the SCPI convention. The SCPI interface enables users to operate the power supply through a computer or a terminal equipped with RS-232, or USB interface. SCPI IEEE-488.2 also supports multi-unit control allowing a user to control up to 32 power supplies.

The following table lists all of the numerical parameters.

Symbol	Response Formats
<bool>	Boolean value, can be 1 or "ON", 0 or "OFF"
<NR1>	Integer value, can be zero, positive or negative integer number
<NRf>	Flexible numerical value, can be zero, positive or negative float point numeric value
<string>	String value, characters enclosed in single or double
<NL>	New line, hex code 0x0Ah
<Rtn>	Return, hex code 0x0Dh

All commands should be ended with the <Rtn> and <NL> and there should be a space between command and numerical parameter.

2.2 IEEE488.2 Common Commands

Here's a list and description of all common SCPI commands supported by the instrument.

*CLS

This command clears the following registers.

Standard event register

Query event register

Operation event register

Status byte register

Error code

Command syntax: *CLS

Parameter: None

*ESE

This command can set the parameter of standard event enable register. Setting parameter can determine which bit of standard event register is 1 and the byte will enable ESB of status byte register as 1.

Command syntax: *ESE <NR1>

Parameter: 0-255

The value when power on: Refer to *PSC command

Example: *ESE 128

Query syntax: *ESE?

Returned parameter: <NR1>

The bit definition of the standard event enabled register:

Bit Position	7	6	5	4	3	2	1	0
Bit Name	PON	Not used	CME	EXE	DDE	QYE	Not used	OPC
Bit Weight	128		32	16	8	4		1

PON Power-on

CME Command error

EXE Execution error

DDE Device-dependent error

QYE Query error

OPC Operation complete

*ESR?

This command can read the value of standard event status register. After executing this command, standard event status register is reset. Bit definition of standard event status register is the same as the standard event status enable register.

Query syntax: *ESR?

Parameter: None

Returned parameter: <NR1>

*IDN?

This command can read information about power supply. The returns parameter contains 4 segments divided by comma.

Query syntax: *IDN?

Parameter: None

Returned parameter: <AARD> segment description

B&K Precision Manufacturer

9801 Product model

XXXXXX Product serial number

VX. XX-VX. XX Software version

Example: B&K Precision, 9801, 00000000000004, V1.01-V1.00

*OPC

When all commands before this command are executed, bit OPC in standard event register will be set to 1.

Command syntax: *OPC

Parameter: None

Query syntax: *OPC?

Returned parameter: <NR1>

***RST**

This command resets the power supply to default settings.

Command syntax: *RST

Parameter: None

***SRE**

This command can set the parameter of state byte enable register. Setting parameter can determine which byte value of state byte register is 1 and the byte will set RQS of state byte register to 1. Bit definition of state byte enable register is the same as the state byte register.

Command syntax: *SRE <NR1>

Parameter: 0~255

Query syntax: *SRE?

Returned parameter: <NR1>

***STB?**

This command can read the data from status byte register.

Query syntax: *STB?

Parameter: None

Returned parameter: <NR1>

***TRG**

When power supply trigger source is a command from via BUS, this command will give a trigger signal. And its function is the same as "TRIGger" command.

Query syntax: *TRG

Parameter: None

Returned parameter: None

***SAV**

This command can save the current setups of power supply to specified memory. The memory is divided into 10 groups, each contain 0~9 (10 total) setups. Up to 100 setups can be saved in total.

Command syntax: *SAV<NRf>

Parameter: 0~9

***RCL**

This command can recall the setups you saved previously from the specified memory location.

Command syntax: *RCL<NRf>

Parameter: 0-9

2.3 STATUS Subsystem

You can get the current status of the power supply by reading the operation status registers. The power supply records the different status of the instrument through the four status register group. The four status register groups are: status byte register, standard event register, query status register and operation status register. Status byte register records the information of the other status registers.

Test Equipment Depot - 800.517.8431 - 99 Washington Street Melrose, MA 02176

TestEquipmentDepot.com

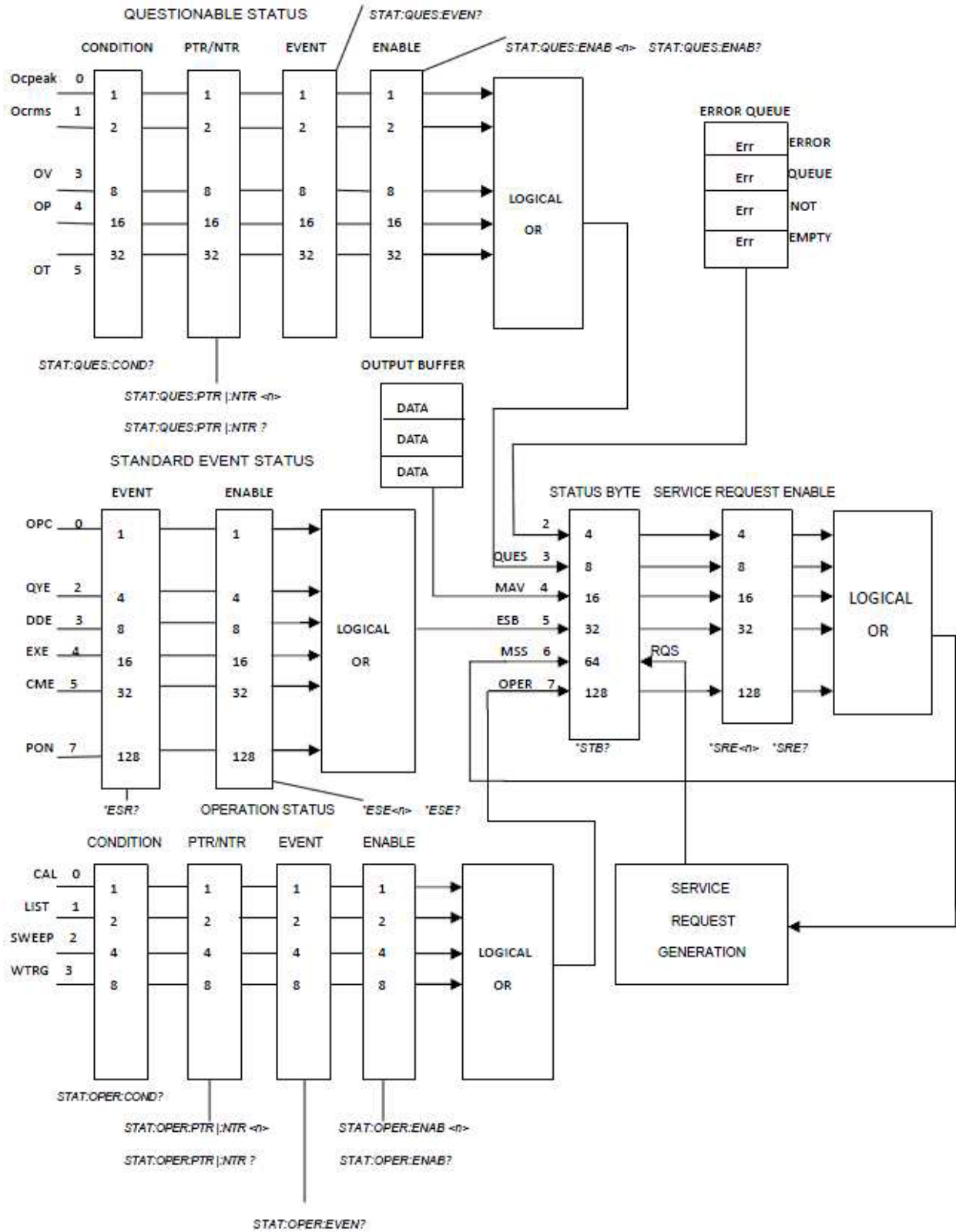

STATUS Subsystem

STATus:QUEStionable[:EVENT]?

This command can be used to read the value in query event register. After executing this command, the query event register will be cleared.

Query syntax: STATus:QUEStionable[:EVENT]?

Parameter: None

Returned parameter: <NR1>

Relative command: STATus:QUEStionable:ENABle

The bit definition of query event enable register:

Bit Position	7	6	5	4	3	2	1	0
Bit Name	Not used	Not used	OT	OP	OV	Not used	OCrms	OC Peak
Bit Weight			32	16	8		2	1

STATus:QUEStionable:CONDition?

This command is used to read the value of query condition register. When a bit of QUES condition changes, the bit value corresponding in QUEST event register is 1.

Query syntax: STATus:QUEStionable: CONDition?

Parameter: None

Returned parameter: <NR1>

STATus:QUEStionable:ENABle

This command can set the parameter of quest event enable register. Setting parameter can determine which bit value of quest event register is 1 and the bit will enable QUES.

Command syntax: STATus:QUEStionable:ENABle <NR2>

Parameter: 0~65535

Default set: Refer to *PSC command

Example: STATus:QUEStionable:ENABle 128

Query syntax: STATus:QUEStionable:ENABle?

Returned parameter: <NR1>

STATus: QUEStionable:NTRansition

This command is used to edit the negative transition trigger register of operation event. The parameter determines which bits of operation event register is 1 and will change the OPER of status byte register to be 1.

Command syntax: STATus: QUEStionable:NTRansition <NR1>

Parameter: 0~255

Example: STATus: QUEStionable:NTRansition 128

Query syntax: STATus: QUEStionable:NTRansition?

STATus: QUEStionable:PTRansition

This command is used to edit the positive transition trigger register of operation event. The parameter determines which bits of operation event register is 1 and will change the OPER of status byte register to be 1.

Command syntax: STATus: QUEStionable:PTRansition <NR1>

Parameter: 0~255

Example: STATus: QUEStionable:PTRansition 128

Query syntax: STATus: QUEStionable:PTRansition?

STATus:OPERation[:EVENT]?

This command can read the parameter from operation event register. After executing this order, operation event register is reset.

Query syntax: STATus:OPERation [:EVENT]?

Parameter: None

Returned parameter: <NR1>

Relative command: STATus: OPERation:ENABLE

Bit definition of operation event register:

Bit Position	7	6	5	4	3	2	1	0
Bit Name	Not used	Not used	Not used	Not used	WTG	SWEEP	LIST	CAL
Bit Weight					8	4	2	1

STATus:OPERation:CONDition?

This command can read the parameter from the operation condition register. When the parameter of operation condition register changes, the bit corresponding in operation event register is 1.

Query syntax: STATus: OPERation: CONDition?

Parameter: None

Returned parameter: <NR1>

STATus:OPERation:ENABLE

This command can set the parameter of operation event enable register. Setting parameter can determine which bit value of operation event register is 1 and the bit will change OPER of status byte register to be 1.

Command syntax: STATus: OPERation:ENABLE <NR1>

Parameter: 0~255

Example: STATus: OPERation:ENABLE 128

Query syntax: STATus: OPERation:ENABLE?

Returned parameter: <NR1>

STATus:OPERation:NTRansition

This command is used to edit the negative transition trigger register of operation event. The

parameter determines which bits in operation event register is 1 and will change the OPER bit of status byte register to be set to 1.

Command syntax: STATus:OPERation:NTRansition <NR1>

Parameter: 0~255

Example: STATus:OPERation:NTRansition 128

Query syntax: STATus:OPERation:NTRansition?

STATus:OPERation:PTRansition

This command edits the positive transition trigger register of operation event. The parameter determines which bits of operation event register is 1 and will change the OPER bit of status byte register to be set to 1.

Command syntax: STATus:OPERation:PTRansition <NR1>

Parameter: 0~255

Example: STATus:OPERation:PTRansition 128

Query syntax: STATus:OPERation:PTRansition?

2.4 SYSTEM Subsystem

SYSTem:ERRor?

This command is used to read the error code and the error information.

Command syntax: SYST:ERR?

Parameter: None

Returned parameter: <NR1>,<SRD>

The following is the error code and the definition:

(101) Too many numeric suffices

(110) No input command

(114) Invalid Numeric suffix

(116) Invalid value

(117) Invalid dimensions

(120) Parameter overflowed

(130) Wrong units for parameter

(140) Wrong type of parameter

(150) Wrong number of parameter

(160) Unmatched quotation mark

(165) Unmatched bracket

(170) Invalid command

(180) No entry in list

(190) Too many dimensions

(191) Too many char

(-200) Execution error

(-221) Settings conflict

(-222) Data out of range

(-223) Too much data

- (-224) Illegal parameter value
- (-225) Out of memory
- (-230) Data Corrupt or Stale
- (-270) Macro error
- (-310) System error
- (-350) Too many errors [errors beyond 9 lost due to queue overflow]
- (-400) Query error
- (-410) Query INTERRUPTED
- (-420) Query UNTERMINATED
- (-430) Query DEADLOCKED
- (-440) Query UNTERMINATED
- (0) No error
- (1) Module Initialization Lost
- (2) Mainframe Initialization Lost
- (3) Module Calibration Lost
- (4) Eeprom failure
- (5) RST checksum failed
- (10) RAM selftest failed
- (40) Flash write failed
- (41) Flash erase failed
- (213) RS-232 buffer overrun
- (216) RS-232 receiver framing
- (217) RS-232 receiver parity
- (218) RS-232 receiver overrun
- (220) Front panel uart overrun
- (221) Front panel uart framing
- (222) Front panel uart parity
- (223) Front panel buffer overrun
- (224) Front panel timeout
- (225) Front Crc Check error
- (226) Front Cmd Error
- (401) CAL switch prevents
- (402) CAL password is incorrect
- (403) CAL not enabled
- (404) readback cal are incorrect
- (405) programming cal are incorrect
- (406) Incorrect sequence of cal
- (603) FETCH of data was not acquired
- (604) Measurement overrange

SYSTem:VERSion?

This command is used to query the current SCPI version. The returned parameter is a string like "YYYY.V", in which the YYYY is the year of that version, V is the software version of that year.

Command syntax: SYST:VERS?

Parameter: None
Returned parameter: <NRf>

SYSTem:REMOte

This command is used to switch to the remote control mode (PC control).

Parameter: None

SYSTem:LOCal

This command is used to switch the instrument to local control mode (front panel control).

Command syntax: SYST:LOCal

Parameter: None

SYSTem:RWLock

This command is the same function as SYSTem:REMOte, except this command can lock "LOCAL" button as well. When this command is executed, the "Local" button will be disabled.

Command syntax: SYSTem:RWLock

Parameter: None

SYSTem:POSetup

This command configures the power on state of the instrument.

Command syntax: SYSTem:POSetup <string>

Parameter: RST|SAV0

Query syntax: SYSTem:POSetup?

Returned parameter: <string>

SYSTem:POSetup?

Command syntax: SYSTem:POSetup?

Parameter: None

Returned parameter: RST|SAV0

SYSTem:CLEar

This command is used to clear the error codes and information.

Command syntax: SYSTem:CLEar

Parameter: None

Returned parameter: None

SYSTem:BEEPer

This command is used to enable or disable the beeper.

Command syntax: SYSTem:BEEPer

Command syntax: SYSTem:BEEPer<bool>

Parameters: 0|1|ON|OFF

Query syntax: SYSTem:BEEPer?

Returned value 0 corresponds to the off state of beeper.

Returned value 1 corresponding to the on state of beeper.

Return parameters: <bool>

SYSTem:INTerface

This command is used to select the communication interfaces.

Command syntax: SYSTem:INTerface <string>

Parameter: < USB|RS232|LAN>

2.5 TRIGGER Subsystem

TRIGger[:IMMEDIATE]

This command is used to create a trigger signal. It will give a trigger signal in BUS trigger source mode. The function is the same as command *TRG.

Command syntax: TRIGger[:IMMEDIATE]

Parameter: None

Related commands: *TRG

TRIGger:SOURce

This command is used to select the trigger source. Power supply can receive trigger signals directly from front panel by pushing "Trigger" button or receive from a BUS trigger signal (using *TRG command).

Command syntax: TRIG:SOURce <string>

Parameters: MANUAL |BUS |EXTErn

Query syntax: TRIGger:SOURce?

Return parameter: <string>

2.6 SOURCE Subsystem

[SOURce:]OUTPut[:STATe]

This command is used to control the output state of the power supply.

Command syntax: [SOURce:]OUTPut [:STATe] <bool>

Parameter: 0|1|ON|OFF

Query syntax: [SOURce:]OUTPut[:STATe]?

Return parameter: <bool>

[SOURce:]RANGe

This command is used to set the voltage and current ranges.

Command syntax: [SOURce:]RANGe <string>

Parameter: AUTO|HIGH

Query syntax: [SOURce:]RANGe?

Return parameter: <string>

[SOURce:]FREQuency[:IMMediate]

This command is used to set the output frequency value.

Command syntax: [SOURce:]FREQuency[:IMMediate] <NRf>

Parameter: MIN TO MAX|MIN|MAX|DEF

Unit: Hz

Query syntax: [SOURce:]FREQuency[:IMMediate]?

Return parameter: <NRf>

[SOURce:]PHASe:START

This command is used to set the start phase angle.

Command syntax: [SOURce:]PHASe:START <NRf>

Parameter: MIN TO MAX|MIN|MAX|DEF

Unit: °

Query syntax: [SOURce:]PHASe:START?

Return parameter: <NRf>

[SOURce:]PHASe:END

This command is used to set the stop phase angle.

Command syntax: [SOURce:]PHASe:END <NRf>

Parameter: MIN TO MAX|MIN|MAX|DEF

Unit: °

Query syntax: [SOURce:]PHASe:END?

Return parameter: <NRf>

[SOURce:]DIMMer[:PHASe]?

This command is used to set the phase of the phase angle dimming function.

Command syntax: [SOURce:]DIMMer[:PHASe]<NRf>

Parameters: MIN TO MAX|MIN|MAX|DEF

Unit: °

Query syntax: [SOURce:]DIMMer[:PHASe]?

Parameter: None

Return parameter: <NRf>

[SOURce:]VOLTage[:LEVel][:IMMediate][:AMPLitude]

This command is used to set a voltage output of the power supply.

Command syntax: [SOURce:]VOLTage[:LEVel][:IMMediate][:AMPLitude] <NRf>

Parameters: MIN TO MAX|MIN|MAX|DEF

Unit: V

Query syntax: [SOURce:]VOLTage[:LEVel][:IMMediate][:AMPLitude]?

Return parameter: <NRf>

2.7 CONFIG Commands

CONFig[SOURce:]VOLTage[:LEVel]:MINimum

This command is used to set the lower limitation (Volt-Min) of the output voltage.

Command syntax: CONFig[SOURce:]VOLTage[:LEVel]:MINimum <NRf>

Parameter: MIN TO MAX | MIN | MAX |

Unit: V

Query syntax: CONFig[SOURce:]VOLTage[:LEVel]:MINimum?

Return parameter: <NRf>

CONFig[SOURce:]VOLTage[:LEVel]:MAXimum

This command is used to set the upper limitation (Volt-Max) of the output voltage.

Command syntax: CONFig[SOURce:]VOLTage[:LEVel]:MAXimum <NRf>

Parameter: MIN TO MAX | MIN | MAX |

Unit: V

Query syntax: CONFig[SOURce:]VOLTage[:LEVel]:MAXimum?

Return parameter: <NRf>

CONFig[SOURce:]FREQuency:MINimum

This command is used to set the lower limitation (Freq-Min) of the output frequency.

Command syntax: CONFig[SOURce:]FREQuency:MINimum <NRf>

Parameter: MIN TO MAX | MIN | MAX |

Unit: Hz

Query syntax: CONFig[SOURce:]FREQuency:MINimum?

Return parameter: <NRf>

CONFig[SOURce:]FREQuency:MAXimum

This command is used to set the upper limitation (Freq-Max) of the output frequency.

Command syntax: CONFig[SOURce:]FREQuency:MAXimum <NRf>

Parameter: MIN TO MAX | MIN | MAX |

Unit: Hz

Query syntax: CONFig[SOURce:]FREQuency:MAXimum?

Return parameter: <NRf>

CONFig:PROTect:CURRent:RMS

This command is used to set the RMS current protection point (Irms-Protect).

Command syntax: CONFig:PROTect:CURRent:RMS <NRf>

Parameter: MIN TO MAX | MIN | MAX |

Unit: A

Query syntax: CONFig:PROTect:CURRent:RMS?

Return parameter: <NRf>

CONFig:PROTect:CURRent:RMS:MODE

This command is used to set the RMS current protection (Irms-Protect) delay mode.

Command syntax: CONFig:PROTect:CURRent:RMS:MODE <NRf>

Parameter: DELay | IMMEDIATE

Query syntax: `CONFig:PROToct:CURRent:RMS:MODE?`
Return parameter: `<NRf>`

CONFig:PROTect:CURRent:PEAK

This command is used to set the peak current protection point (I_{peak-Protect}).

Command syntax: `CONFig:PROToct:CURRent:PEAK <NRf>`

Parameter: `MIN TO MAX | MIN | MAX |`

Unit: A

Query syntax: `CONFig:PROToct:CURRent:PEAK?`

Return parameter: `<NRf>`

CONFig:PROTect:CURRent:PEAK:MODE

This command is used to set the peak current protection (I_{peak-Protect}) delay mode.

Command syntax: `CONFig:PROToct:CURRent:PEAK:MODE <NRf>`

Parameter: `DELay | IMMEDIATE`

Query syntax: `CONFig:PROToct:CURRent:PEAK:MODE?`

Return parameter: `<NRf>`

CONFig:BNC[:PORT][:FUNCTION]

This command is used to configure the BNC terminal functionality.

Command syntax: `CONFig:BNC[:PORT][:FUNCTION]<NRf>`

Parameter: `I-TRigger | I-RI | O-PHase | O-ON`

Example: `CONF:BNC I-TR`

Query syntax: `CONFig:BNC[:PORT][:FUNCTION]?`

Return parameter: `<NRf>`

CONFig:DIMMer:MODE

This command is used to configure the dimmer mode to either leading/trailing edge or off.

Command syntax: `CONFig:DIMMer:MODE <NRf>`

Parameter: `LEADingedge | TRAILingedge | OFF`

Query syntax: `CONFig:DIMMer:MODE?`

Return parameter: `<NRf>`

CONFig:LIST:START:MODE

This command is used to configure the mode to start/initiate a list program. This controls the List-Set setting in the menu.

Command syntax: `CONFig:LIST:START:MODE <NRf>`

Parameter: `ON/OFF | TRIGGER`

Example: `CONF:LIST:STAR ON/OFF`

Query syntax: `CONFig:LIST:START:MODE?`

Return parameter: `<NRf>`

2.8 MEASURE and FETCH Commands

MEASure[:SCALar]:VOLTage[:AC]?

This command is used to query the actual output AC voltage.

Command syntax: MEASure[:SCALar]:VOLTage[:AC]?

Return parameter: <NRf>

Return parameter unit: V

Example: MEAS:VOLT?

FETCh[:SCALar]:VOLTage[:AC]?

This command is used to read the output AC voltage which is in the sample cache. After sending the command, the readings will be sent to the computer. This command does not affect the instrument settings. This command does not trigger a measurement operation, and queries only the latest available reading. Before reading the new reading, the command returns old readings.

Command syntax: FETCh:VOLTage?

Return parameter: <NRf>

Return parameter unit: V

MEASure[:SCALar]:CURRent[:AC]?

This command is used to query the actual output AC current.

Command syntax: MEASure[:SCALar]:CURRent[:AC]?

Return parameter: <NRf>

Return parameter unit: A

example: MEAS:CURR?

FETCh[:SCALar]:CURRent[:AC]?

This command is used to read the output AC current which is in the sample cache. After sending the command, the readings will be sent to the computer. This command does not affect the instrument settings. This command does not trigger a measurement operation, and queries only the latest available reading. Before reading the new reading, the command returns the old readings.

Command syntax: FETCh:CURRent?

Return parameter: <NRf>

Return parameter unit: A

MEASure[:SCALar]:POWer[:AC][:REAL]?

This command is used to query the actual output active power.

Command syntax: MEASure[:SCALar]:POWer[:AC][:REAL]?

Return parameter: <NRf>

Return parameter unit: W

Example: MEAS:POWer?

FETCh[:SCALar]:POWer[:AC]:REAL?

This command is used to read the output power which is in the sample cache. After sending the command, the readings will be sent to the computer. This command does not affect the instrument settings. This command does not trigger a measurement operation, and queries only the latest available reading. Before reading the new reading, the command returns the old readings.

Command syntax: FETCh:POWer?

Return parameter: <NRf>

Return parameter unit: W

MEASure[:SCALar]:POWer[:AC]:APParent?

This command is used to query the actual output apparent power.

Command syntax: MEASure[:SCALar]:POWer[:AC]:APParent?

Return parameter: <NRf>

Return parameter unit: VA

Example: MEAS:POWer:APP?

FETCh[:SCALar]:POWer[:AC]:APParent?

This command is used to read the output apparent power which is in the sample cache. After sending the command, the readings will be sent to the computer. This command does not affect the instrument settings. This command does not trigger a measurement operation, and queries only the latest available reading. Before reading the new reading, the command returns the old readings.

Command syntax: FETCh:POWer:APParent?

Return parameter: <NRf>

Return parameter unit: VA

MEASure[:SCALar]:POWer[:AC]:PFACTOR?

This command is used to query the actual power factor.

Command syntax: MEASure[:SCALar]:POWer[:AC]:PFACTOR?

Return parameter: <NRf>

Example: MEAS:POWer:PFAC?

FETCh[:SCALar]:POWer[:AC]:PFACTOR?

This command is used to read the power factor which is in the sample cache. After sending the command, the readings will be sent to the computer. This command does not affect the instrument settings. This command does not trigger a measurement operation, and queries only the latest available reading. Before reading the new reading, the command returns the old readings.

Command syntax: FETCh:POWer:PFACTOR?

Return parameter: <NRf>

MEASure[:SCALar]:FREQuency?

This command is used to query the actual output frequency.

Command syntax: MEASure[:SCALar]:FREQuency?

Parameter: None

Return parameter: <NRf>

Return parameter unit: Hz

Example: MEAS:FREQ?

FETCh[:SCALar]:FREQuency?

This command is used to read the output frequency which is in the sample cache. After sending the command, the readings will be sent to the computer. This command does not affect the instrument settings. This command does not trigger a measurement operation, and queries only the latest available reading. Before reading the new reading, the command returns the old readings.

Command syntax: FETCh:FREQuency?

Return parameter: <NRf>

Return parameter unit: Hz

MEASure[:SCALar]:CURRent[:AC]:PEAK?

This command is used to query the actual output AC current peak.

Command syntax: MEASure[:SCALar]:CURRent[:AC]:PEAK?

Return parameter: <NRf>

Return parameter unit: A

Example: MEAS:CURR:PEAK?

FETCh[:SCALar]:CURRent[:AC]:PEAK?

This command is used to read the output AC current peak which is in the sample cache. After sending the command, the readings will be sent to the computer. This command does not affect the instrument settings. This command does not trigger a measurement operation, and queries only the latest available reading. Before reading the new reading, the command returns the old readings.

Command syntax: FETCh:CURR:PEAK?

Return parameter: <NRf>

Return parameter unit: A

MEASure[:SCALar]:CURRent[:AC]:PEAK:MAXimum?

This command is used to query the actual maximum output AC current peak.

Command syntax: MEASure[:SCALar]:CURRent[:AC]:PEAK:MAXimum?

Return parameter: <NRf>

Return parameter unit: A

Example: MEAS:CURR:PEAK:MAX?

FETCh[:SCALar]:CURRent[:AC]:PEAK:MAXimum?

This command is used to read the maximum output AC current peak which is in the sample

cache. After sending the command, the readings will be sent to the computer. This command does not affect the instrument settings. This command does not trigger a measurement operation, and queries only the latest available reading. Before reading the new reading, the command returns the old readings.

Command syntax: FETCh:CURR:PEAK:MAX?

Return parameter: <NRf>

Return parameter unit: A

2.9 LIST Commands

LIST:STATe

This command is used to set the state of list mode.

Command syntax: LIST:STATe <string>

Parameter: < DISable|ENABLE >

Query syntax: LIST:STATe?

Return parameter: <string>

LIST:RECall

This command is used to recall a list file.

Command syntax: LIST:RECall <NR1>

Parameter: 0 ~ 9

Example: LIST:REC 6

Query syntax: LIST:RECall?

Return parameter: <NR1>

LIST:STEP:COUNT

This command is used to set the number of steps in a list file.

Command syntax: LIST:STEP:COUNT <NR1>

Parameter: 1 ~ 100

Example: LIST:STEP:COUN 5

Query syntax: LIST:STEP:COUNT?

Return parameter: <NR1>

LIST:REPeat

This command is used to edit the number of repeat times of the list file.

Command syntax: LIST:REPeat <NR1>

Parameter: 1 ~ 10000

Example: LIST:REP 20

Query syntax: LIST:REPeat?

Return parameter: <NR1>

LIST:STEP:VOLTage

This command is used to edit the voltage level for a single step in the list file.

Command syntax: LIST:STEP:VOLTage <NR1>,<NRf>

Parameter 1: 0 ~ 99

Parameter 2: Voltage, unit: V

Example: LIST:STEP:VOLT 1, 30

Query syntax: LIST:STEP:VOLTage? <NR1>

Query Example: LIST:STEP:VOLT? 1

Return Parameter: <NRf>

LIST:STEP:FREQuency

This command is used to edit the frequency for a single step in the list file.

Command syntax: LIST:STEP: FREQuency <NR1>,<NRf>

Parameter 1: 0 ~ 99

Parameter 2: Frequency, unit: Hz

Example: LIST:STEP:FREQ 2, 60

Query syntax: LIST:STEP: FREQuency? <NR1>

Query Example: LIST:STEP:FREQ? 2

Return Parameter: <NRf>

LIST:STEP:SLOPe

This command is used to edit the slope time for a single step in the list file.

Command syntax: LIST:STEP:SLOPe <NR1>,<NRf>

Parameter 1: 0 ~ 99

Parameter 2: Slope time, unit: s

Example: LIST:STEP:SLOPe 3, 5.5

Query syntax: LIST:STEP:SLOPe? <NR1>

Query Example: LIST:STEP:SLOPe? 3

Return Parameter: <NRf>

LIST:STEP:DWELI:UNIT

This command is used to edit the dwell time **units** for a single step in the list file.

Command syntax: LIST:STEP:DWELI:UNIT <NR1>,< string >

Parameter 1: 0 ~ 99

Parameter 2: SECond|MINUte|HOUR

Example: LIST:STEP:DWELI:UNIT 2, SEC

Query syntax: LIST:STEP:DWELI:UNIT? <NR1>

Query Example: LIST:STEP:DWELI:UNIT? 3

Return Parameter: <string>

LIST:STEP:DWELI

This command is used to edit the dwell time for a single step in the list file.

Command syntax: LIST:STEP:DWELI <NR1>,<NRf>

Parameter 1: 0 ~ 99

Parameter 2: Dwell time

Example: LIST:STEP:DWELI 3, 20

Query syntax: LIST:STEP:DWELI? <NR1>

Query Example: LIST:STEP:DWEL? 3

Return Parameter: <NRf>

LIST:STEP:SD:STATe

This command is used to enable or disable the disturbance simulation status for a single step in the list file.

Command syntax: LIST:STEP:SD:STAT <NR1>,<string>

Parameter 1: 0 ~ 99

Parameter 2: DISable|ENABLE

Example: LIST:STEP:SD:STAT 3, DIS

Query syntax: LIST:STEP:SD:STAT? <NR1>

Query Example: LIST:STEP:SD:STAT? 2

Return Parameter: <string>

LIST:STEP:SD:CONTInue

This command is used to turn on or off the continuous trigger for disturbance simulation for a single step in the list file.

Command syntax: LIST:STEP:SD:CONTInue <NR1>,<bool>

Parameter 1: 0 ~ 99

Parameter 2: OFF|ON|0|1

Example: LIST:STEP:SD:CONT 3, ON

Query syntax: LIST:STEP:SD:CONTInue? <NR2>

Query Example: LIST:STEP:SD:CONT? 2

Return Parameter: <bool>

LIST:STEP:SD:VOLTage

This command is used to set the voltage surge for disturbance simulation for a single step in the list file.

Command syntax: LIST:STEP:SD:VOLTage <NR1>,<NRf>

Parameter 1: 0 ~ 99

Parameter 2: Voltage, unit: V

Example: LIST:STEP:SD:VOLT 2, 30

Query syntax: LIST:STEP:SD:VOLTage? <NR2>

Query Example: LIST:STEP:SD:VOLT? 2

Return Parameter: <NRf>

LIST:STEP:SD:SITe

This command is used to set the initial time the disturbance occurs for a single step in the list file.

Command syntax: LIST:STEP:SD:SITe <NR1>,<NRf>

Parameter 1: 0 ~ 99

Parameter 2: Time, unit: ms

Example: LIST:STEP:SD:SIT 5, 10

Query syntax: LIST:STEP:SD:SITe? <NR1>

Query Example: LIST:STEP:SD:SIT? 2

Return Parameter: <NRf>

LIST:STEP:SD:TIME

This command is used to set the duration of the disturbance for a single step in the list file.

Command syntax: LIST:STEP:SD:SITe <NR1>,<NRf>

Parameter 1: 0 ~ 99

Parameter 2: Time, unit: ms

Example: LIST:STEP:SD:TIM 3, 20

Query syntax: LIST:STEP:SD:TIME? <NR1>

Query Example: LIST:STEP:SD:TIM? 2

Return Parameter: <NRf>

LIST:SAVe:BANK

This command is used to save a list file into a specified memory location.

Command syntax: LIST:SAVe:BANK <NR1>

Parameter: 0 ~ 9

Example: LIST:SAV:BANK 0

LIST:RUN:STEP:COUNT?

This command is used to query the step currently running

Query syntax: LIST:RUN:STEP:COUNT?

Parameter: None

LIST:RUN:STEP:REPeat?

This command is used to query the step currently running

Query syntax: LIST:RUN:STEP:REPeat?

Parameter: None

2.10 SWEEP Commands

SWEEp:STATe

This command is used to set the state of sweep mode.

Command syntax: SWEEp:STATe <string>

Parameter: < DISable | ENABLE >

Example: SWE:STAT ENAB

Query syntax: SWEEp:STATe?

Return parameter: <string>

SWEep:RECall

This command is used to recall a sweep setup file.

Command syntax: SWEep:RECall <NR1>

Parameter: 0 ~ 9

Example: SWE:REC 4

Query syntax: SWEep:RECall?

Return parameter: <NR1>

SWEep:STARt:VOLTage

This command is used to edit the sweep starting voltage.

Command syntax: SWEep:STARt:VOLTage <sNRf>

Parameter: MINimum|MAXimum|<NRf>

Parameter unit: V

Example: SWE:STAR:VOLT 5

Query syntax: SWE:STAR:VOLT?

Return parameter: <NRf>

SWEep:END:VOLTage

This command is used to edit the sweep starting voltage.

Command syntax: SWEep:END:VOLTage <sNRf>

Parameter: MINimum|MAXimum|<NRf>

Parameter unit: V

Example: SWE:END:VOLT 5

Query syntax: SWE:END:VOLT?

Return parameter: <NRf>

SWEep:STEP:VOLTage

This command is used to edit the sweep voltage step.

Command syntax: SWEep:STEP:VOLTage <NRf>

Parameter: MINimum|MAXimum|<NRf>

Parameter unit: V

Example: SWE:STEP:VOLT 10.2

Query syntax: SWEep:STEP:VOLTage?

Return Parameter: <NRf>

SWEep:STEP:TIME:UNIT

This command is used to set the sweep time unit for a single step.

Command syntax: SWEep:STEP:VOLTage <NRf>

Parameter: SECond|MINUte|HOUR

Example: SWE:STEP:TIM:UNIT SEC

Query syntax: SWEep:STEP:VOLTage?

Return Parameter: <NRf>

SWEep:STEP:TIME

This command is used to edit the sweep time for a single step.

Command syntax: SWEep:STEP:TIME <NRf>

Parameter 1: MINimum|MAXimum|<NRf>

Parameter unit: ms

Example: SWE:STEP:TIM 2, 60

Query syntax: SWEep:STEP:TIME?

Return Parameter: <NRf>

SWEep:START:FREQUENCY

This command is used to edit the sweep starting frequency.

Command syntax: SWEep:START:FREQUENCY <NRf>

Parameter: MINimum|MAXimum|<NRf>

Parameter unit: Hz

Example: SWE:STAR:FREQ 50

Query syntax: SWEe:START:FREQUENCY?

Return parameter: <NRf>

SWEep:END:FREQUENCY

This command is used to edit the sweep ending frequency.

Command syntax: SWEep:END:FREQUENCY <NRf>

Parameter: MINimum|MAXimum|<NRf>

Parameter unit: Hz

Example: SWE:END:FREQ 100

Query syntax: SWEep:END: FREQUENCY?

Return Parameter: <NRf>

SWEep:STEP:FREQUENCY

This command is used to edit the sweep frequency step.

Command syntax: SWEep:STEP:FREQUENCY <NRf>

Parameter : MINimum|MAXimum|<NRf>

Parameter unit: Hz

Example: SWE:STEP:FREQ 10

Query syntax: SWEep:STEP:FREQUENCY?

Return Parameter: <NRf>

SWEep:SAVe:BANK

This command is used to save a sweep file into a specified memory location.

Command syntax: SWEep:SAVe:BANK <NR1>

Parameter: 0 ~ 9

Example: SWE:SAV:BANK 0

SWEep:MEASure[:SCALar]:VOLTage[:AC]?

This command is used to query the output AC voltage at the sweep maximum power point.

Query syntax: **SWEep:MEASure[:SCALar]:VOLTage[:AC]?**

Return parameter: <NRf>

Return parameter unit: V

SWEep:MEASure[:SCALar]:CURRent[:AC]?

This command is used to query the output AC current at the sweep maximum power point.

Query syntax: **SWEep:MEASure[:SCALar]:CURRent[:AC]?**

Return parameter: <NRf>

Return parameter unit: A

SWEep:MEASure[:SCALar]:POWer[:AC][:REAL]?

This command is used to query the output active power at the sweep maximum power point.

Query syntax: **SWEep:MEASure[:SCALar]:POWer[:AC][:REAL]?**

Return parameter: <NRf>

Return parameter unit: W

SWEep:MEASure[:SCALar]:POWer[:AC]:APParent?

This command is used to query the output apparent power at the sweep maximum power point.

Query syntax: **SWEep:MEASure[:SCALar]:POWer[:AC]:APParent?**

Return parameter: <NRf>

Return parameter unit: VA

SWEep:MEASure[:SCALar]:POWer[:AC]:PFACTOR?

This command is used to query the power factor at the sweep maximum power point.

Query syntax: **SWEep:MEASure[:SCALar]:POWer[:AC]:PFACTOR?**

Return parameter: <NRf>

Return parameter unit: None

SWEep:MEASure[:SCALar]:FREQuency?

This command is used to query the output frequency at the sweep maximum power point.

Query syntax: **SWEep:MEASure[:SCALar]:FREQuency?**

Parameter: None

Return parameter: <NRf>

Return parameter unit: Hz

BK PRECISION[®]

Test Equipment Depot - 800.517.8431 - 99 Washington Street Melrose, MA 02176
TestEquipmentDepot.com

v033015