

# INSTRUCTION MANUAL

---

**ADJUSTABLE  
DC REGULATED POWER SUPPLY**

## 5. MAINTENANCE

### WARNING

The following instructions are for use by qualified personnel only. To avoid electrical shock, do not perform any servicing other than contained in the operating instructions unless you are qualified to do so.

#### Fuse Replacement

If the fuse blows, the CV or CC indicators will not light and the power supply will not operate. The fuse should not normally open unless a problem has developed in the unit. Try to determine and correct the cause of the blown fuse, then replace only with a fuse of the correct rating and type.

The fuse is located on the rear panel (see Fig.3-2).

Specifications are subject to change without notice.

# CONTENTS

**(4) 5V Fixed Power Supply Operation**

The fixed 5V supply provides a 5V DC output with a 3 amp current capacity. The supply is ideal for use with TTL circuits.

- A. Turn off the power supply and the equipment to be powered during hook-up.
- B. Connect the polarity the device being powered to the red (+) terminal of the 5V supply.
- C. Connect the negative polarity of the device being powered to the black (-) terminal of the 5V supply.
- D. If the red OVERLOAD indicator lights, too much load has been placed on the supply. This will cause voltage and current to drop and prevent proper operation of the 5V supply. This will cause voltage and current to drop and prevent proper operation of the 5V supply. To correct this situation, the load on the supply must be decreased so that no more than 3 amps of current are sucked.

SECTION PAGE	PAGE
<b>1. INTRODUCTION</b> -----	1
<b>2. SPECIFICATIONS</b> -----	2
2-1 General-----	2
2-2 Operation Mode -----	2
2-3 Constant Voltage Operation-----	3
2-4 Constant Current Operation-----	3
2-5 Tracking Operation-----	3
2-6 Meter -----	4
2-7 5V Output Specifications-----	4
2-8 Insulation-----	4
<b>3. PANEL CONTROLS AND INDICATORS</b> -----	4
3-1 Front Panel-----	6
3-2 Rear Panel-----	7
<b>4. OPERATION INSTRUCTIONS</b> -----	7
4-1 Precaution -----	7
4-2 Setting Current Limit-----	9
4-3 Constant Voltage/Constant Current Characteristic-----	9
4-4 Operation Mode-----	11
(1) Independent Operation-----	11
(2) Series Tracking Operation-----	12
(3) Parallel Tracking Operation-----	14
(4) 5V Fixed Power Supply Operation-----	15
<b>5. MAINTENANCE</b> -----	16
Fuse Replacement-----	16

## 1. INTRODUCTION

Adjustable DC power supply are designed to be used in applications such as powering operational amplifier, push pull stages, logic circuit and definition systems where plus and minus voltages are required to track with an insignificant error, and in any application where three independent power supplies housed in a single package represent an operating convenience.

The instruments consist of two identical, independently adjustable and one fixed 5V/3A DC power supplies. A front panel switch selects one of three modes of operation: independent, series and parallel. In the independent mode, the output voltage and current of each supply are controlled separately, and each supply is isolated up to 300V from output to chassis or output to output. In the tracking mode, both outputs are automatically connected in series or parallel, and the controls of the left supply adjust the magnitudes of both the positive and negative output voltages. Because the outputs are connected in a tracking configuration, any internal disturbance in the master supply (such as drift or ripple) will cause an equal percentage change in the outputs of both the supplies.

Each power supply is a completely transistorized, well-regulated, constant voltage/constant current supply that will furnish full rated output voltage at the maximum output current or can be continuously adjusted throughout the output range. The front panel current controls can be used to establish the output current limit (overload or short circuit) when the supply is used as a constant voltage source (independent or tracking modes) and the voltage controls can be used to establish the voltage limit (ceiling) when the supply is used as a constant current source (independent mode only). The supply will automatically cross over from constant voltage to constant current operation (current limited operation in the tracking mode) and vice versa if the output current or voltage exceeds these preset limits. Each supply had its own front panel meter that can measure output voltage and current. One power supply may be used as a master supply controlling, one slave supplies furnishing various voltages or current for a system. When operated with the front panel mode switch in the tracking position, the instrument is automatically internally connected in auto-tracking configuration.

Another feature of this instrument is its output ON/OFF key.

- a. For model A/B, it is only the key to cut off or resume the output as other similar instrument.

### (3) Parallel Tracking Operation

In the parallel tracking mode of operation, both supplies are strapped together (in parallel). This allows for a rating voltage supply with a double rating current capability. Only the MASTER output terminals are used for parallel tracking operation. In the parallel tracking mode, the SLAVE supply output voltage and current are tracking the MASTER supply output voltage and current.

- A. Set the power supplies to the TRACKING PARALLEL mode by engaging both TRACKING switches.
- B. Because both voltage and current of the SLAVE supply track the MASTER supply, the maximum current and voltage are set using the MASTER controls. Using the MASTER supply output jacks, follow the instructions for "Setting Current Limit" (4-2 Section). Remember that the actual current output at the MASTER supply output jack is double the reading on the SLAVE indicator meter. Then push the output on/off key to enter voltage and current setting.
- C. Adjust the output voltage to the desired level using the MASTER VOLTAGE controls.
- D. Turn off the power supply and the equipment to be powered during hook-up.
- E. Connect the positive polarity of the device being powered to the red (+) terminal of the MASTER power supply.
- F. Connect the negative polarity of the device being powered to the black (-) terminal of the MASTER power supply.

The configuration as shown in Fig.4-5.

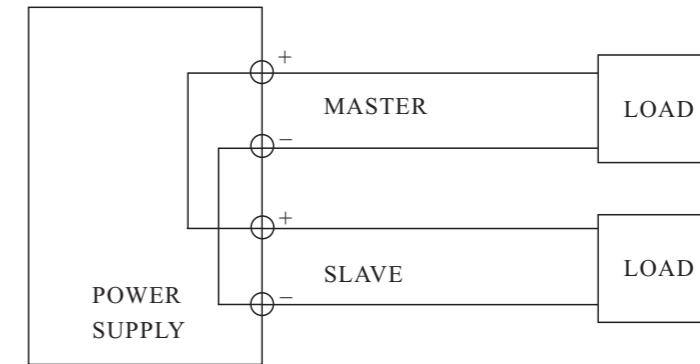

Fig.4-5 Parallel Tracking Operation.

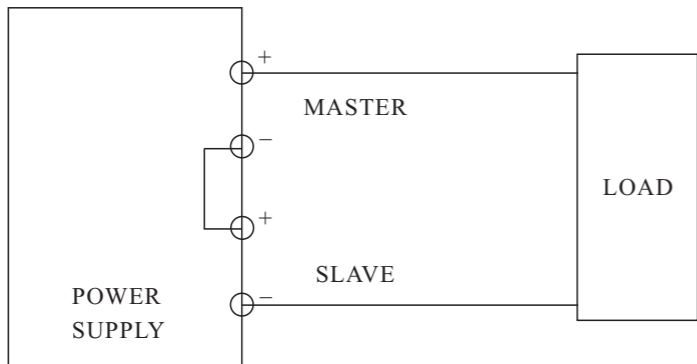

Fig.4-3 Single Supply

If the chassis or common of the equipment being powered is separate from both positive and negative polarity power inputs. The output of the SLAVE (negative) supply is tracking the output of the MASTER (positive) supply. The configuration is shown in

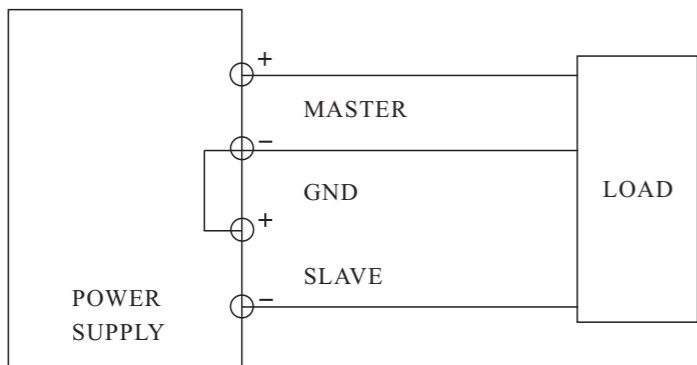

Fig.4-4 Positive and Negative Supply.

b. For model C/D, it is not only the key to cut off or resume the output, but also be endowed with a new function which its Kindred has not. This function is that when the output has been cut off, the both intending voltage and current can be preset, though in model A/B condition, only the intending voltage can be adjusted. It means that CC preset is very easy as CV preset. Also in this way, an over current by any unknown load can be avoided. So the new function of the key is a safety design. Especially this feature is very important to the student use

## 2. SPECIFICATIONS

### 2-1 General

Power Source: AC 110V/220V ( ±10%) 50/60Hz

Operation Temperature & Humidity 0 °C to 40 °C, <80%

Storage Temperature & Humidity -10 °C to 70 °C, <70%

Accessories

Power cord -----1

Operation Manual-----1

### Rating

Model Specifications	A PS - 2303	B PS - 2305	C PS - 2303E	D PS - 2305E
Output voltage	2 × 0~30V	2 × 0~30V	2 × 0~30V	2 × 0~30V
Output current	2 × 0~3A	2 × 0~5A	2 × 0~3A	2 × 0~5A
Output fixed	5V,3A	5V,3A	5V,3A	5V,3A
Output on/off V/A initializes	O	O		

Dimensions: 245(W) × 140(H) × 345(D)mm

Weight: Approx.8kg

### 2-2 Operation Mode

(1). Independent: Two independent outputs and 5V fixed output.

Output from 0 to rating volts and 0 to rating amperes.

- (2). Series: Output from 0 to  $\pm$  rating volts at rating amperes each.  
Output from 0 to double rating volts at rating amperes.
- (3). Parallel: Output from 0 to double rating amperes at rating volts.

#### 2-3 Constant Voltage Operation

- (1). Output current range 0~rating voltage continuously adjustable.
- (2). Regulation  
Line regulation  $\leq 0.01\% + 3\text{mV}$ .  
Load regulation  $\leq 0.01\% + 3\text{mV}$  (rating current  $\leq 3\text{A}$ )  
Load regulation  $\leq 0.02\% + 5\text{mV}$  (rating current  $> 3\text{A}$ )
- (3). Recovery time  $\leq 100\mu\text{s}$  (50% Load change, Minimum load 0.5A)
- (4). Ripple & Noise  $\leq 1\text{mV rms}$ , 5Hz~1MHz.
- (5). Temperature coefficient  $\leq 300\text{PPM}/^\circ\text{C}$

#### 2-4 Constant Current Operation

- (1). Output current range 0~rating current continuously adjustable.
- (2). Regulation  
Line regulation  $\leq 0.2\% + 3\text{mA}$ .  
Load regulation  $\leq 0.2\% + 3\text{mA}$ .
- (3). Ripple current  $\leq 3\text{mA rms}$ .

#### 2-5 Tracking Operation

- (1). Parallel operation  
Regulation  
Line regulation  $\leq 0.01\% + 3\text{mV}$ .  
Load regulation  $\leq 0.01\% + 3\text{mV}$  (rating current  $\leq 3\text{A}$ )  
 $\leq 0.02\% + 5\text{mV}$  (rating current  $> 3\text{A}$ )
- (2). Series operation  
Regulation  
Line regulation  $\leq 0.01\% + 5\text{mV}$ .  
Load regulation  $\leq 300\text{mV}$

A. Positive and Negative supply (Fig.4-4).

#### (2) Series Tracking Operation

When the series tracking mode of operation is selected, the positive (red) terminal of the SLAVE supply output is internally connected to the negative (black) terminal of the MASTER supply.

In the series tracking mode, the maximum output voltage of both MASTER and SLAVE supplies can be simultaneously varied with one control. The maximum SLAVE supply voltage is automatically set to the same value as the MASTER supply by using the MASTER VOLTAGE controls.

- A. Set the power supplies to the TRACKING SERIES mode by engaging the left TRACKING switch and release the right TRACKING switch. In this case, the output voltage (across the two supplies) is actually double the displayed value. For example, if the MASTER display is set for voltage metering and the SLAVE display for current metering, the output voltage across the MASTER positive (red) terminal and the SLAVE negative (black) terminal would be double the reading on the MASTER LED Display (since both supplies are putting out the same voltage). The actual output current would be the value read from the SLAVE LED Display (since the two supplies are wired in series, current flowing through each supply must be equal).
- B. Set the SLAVE CURRENT control the fully clockwise position. The maximum current is set using the MASTER CURRENT control. Follow the instructions for " Setting Current Limit" (INDEPENDENT USE OF " MASTER" OR " SLAVE" SUPPLY section of this manual, using the MASTER CURRENT control.

#### NOTE:

Because the supplies are being used in series, either CURRENT control can be used to set maximum current. If desired, the MASTER CURRENT control can be rotated fully clockwise and the SLAVE CURRENT control can be used to adjust the maximum current value. Because current through the two supplies must be equal when they are being used in series, the lower CURRENT control setting will set the maximum output current.

- C. Adjust the output voltage the desired level using the MASTER VOLTAGE controls.
- D. Turn off the power supply and the equipment to be powered during hook-up.
- E. If " single supply" operation is desired, this allows the power supply to be used as twice the voltage and rating current simply by using the negative (black) terminal of the SLAVE supply and the positive (red) terminal of the MASTER supply, the configuration as shown in Fig.4-3.

#### 4-4 Operation Mode

##### (1) Independent Operation

The " MASTER " and " SLAVE " supplies each provide a 0 to rating volts output at up to rating amps. This procedure covers the use of the MASTER and SLAVE supplies only when they are used independently from one another. When used in the INDEPENDENT operating mode, the operating controls of the two power supplies are completely independent and either supply can be used individually or both can be used simultaneously.

- A. Disengage both TRACKING mode switches (both switches out) so that the power supply is in the INDEPENDENT operating mode.
- B. Adjust " Voltage" control and " Current " control to the desired output voltage and current.
- C. Turn off the power supply and the equipment to be powered during hook-up.
- D. Connect the positive polarity of the device being powered to the red (+) terminal of the power supply.
- E. Connect the negative polarity of the device being powered to the black (-) terminal of the power supply.
- F. Fig.4-2 illustrates the connection procedure.

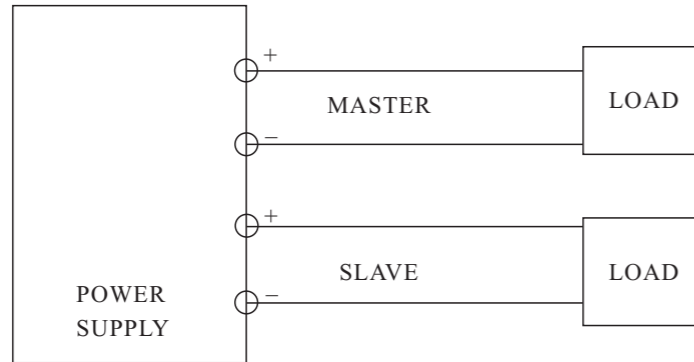

Fig.4-2 Independent Operation.

Slave tracking error  $\leq 0.5\% + 10\text{mV}$  of the master  
(No load, with load add Load regulation  $\leq 300\text{mV}$ ).

##### B. Single supply (Fig.4-3)

#### 2-6 Meter

- A. Display: 3 Digits panel meter  $\times 3$  (0.4" Red LED display  $\times 2$ , 0.4" Green LED display  $\times 2$ )
- B. Accuracy:  $\pm(0.5\%$  of rdg +2 digits)  
(NOTE: Model C/Model D Out OFF Accuracy  $\pm(0.5\%$  of rdg +8 digits)).
- C. Voltmeter: 99.9V of full scale.
- D. Ammeter: 9.99A of full scale.

#### 2-7 5V Output Specifications

1. Regulation Line regulation  $\leq 10\text{mV}$ , Load regulation  $\leq 15\text{mV}$
2. Ripple & Noise  $\leq 2\text{mV rms}$ , 5Hz~1MHz.
3. Voltage accuracy  $5\text{V} \pm 0.25\text{V}$
4. Output current 3A

#### 2-8 Insulation

- Between chassis and output terminal 20M $\Omega$  or above (DC 500V)  
Between chassis and AC cord 300M $\Omega$  or above (DC 500V)

### 3. PANEL CONTROLS AND INDICATORS



Fig.3-1 Front Panel

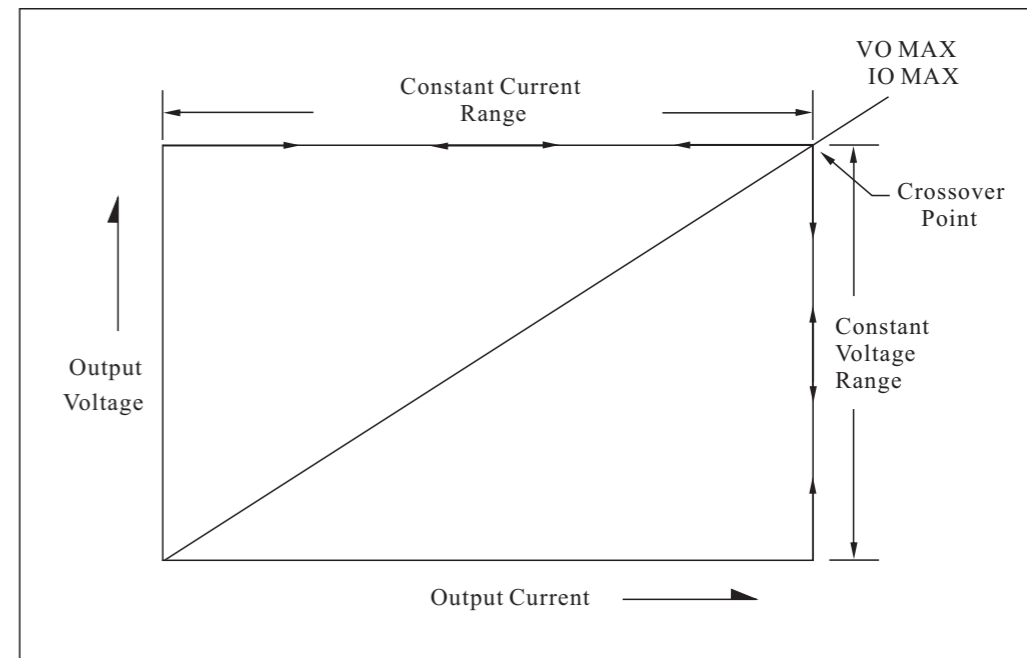
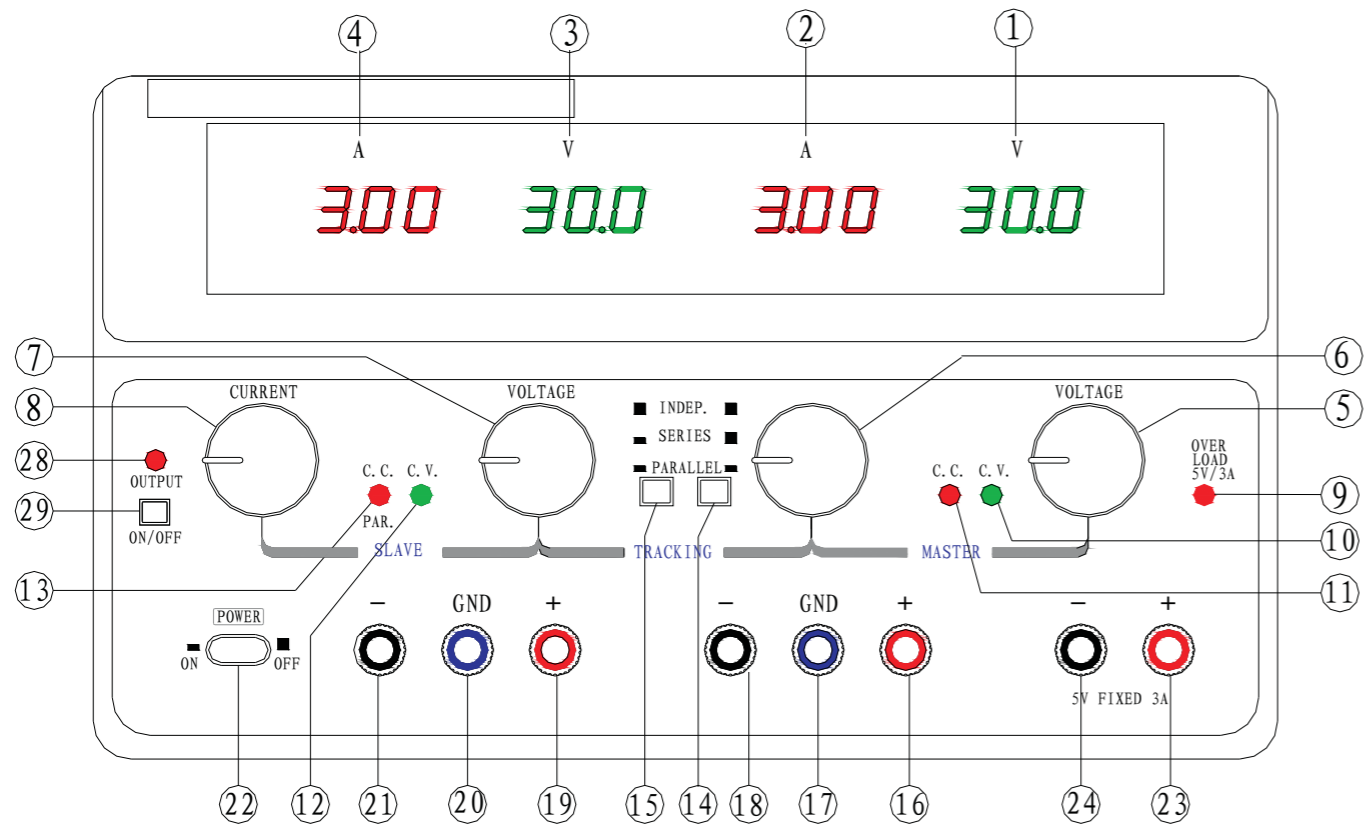

Fig.4-1 Constant Voltage/Constant Characteristic.

### (3). Output voltage overshoot

Maybe voltage between output terminals exceeds the present value when the power is turned on or off.

#### 4-2 Setting Current Limit

- (1). Determine the maximum safe current for the device to be powered.
- (2). In general, the (+) and (-) terminals of the power supply should be temporarily short together with a test lead. But in this instrument (Only model C/D), just pushing the output on/off kdy can make the short-circuit function.
- (3). Rotate the VOLTAGE control away from zero sufficiently for the CC indicator to light.
- (4). Adjust the CURRENT control for the desired current limit. Read the current value on the A meter.
- (5). The current limit (overload protection) has now been preset. Do not change the CURRENT control setting after this step.
- (6). Remove the short between (+) and (-) terminals and hook up for constant voltage operation.

#### 4-3 Constant Voltage/Constant Current Characteristic

The working characteristic of this series Power Supplies is called a constant voltage/constant current automatic crossover type. This permits continuous transition from constant current to constant voltage modes in response to the load change. The intersection of constant voltage and constant current modes is called the crossover point. Fig.4-1 shows the relationship between this crossover point and the load.

For example, if the load is such that the power supply is operating in the constant voltage mode, a regulated output voltage is provided. The output voltage remains constant as the load increases up until the point where the preset current limit is reached. At that point, the output current becomes constant and the output voltage drops in proportion to further increases in load. The point is indicated by the front panel LED indicators. The crossover point is reached when the CV indicator goes off and the CC indicator comes on.

Similarly, crossover from the constant current to the constant voltage mode automatically occurs from a decrease in load. A good example of this would be seen when charging a 12-volt battery. Initially, the open circuit voltage of the power supply may be preset for 13.8 volts. A low battery will place a heavy load on the supply and it will operate in the constant current mode, which may be adjusted for a 1 amp charging rate. As the battery becomes charged, and its voltage approaches 13.8 volts, its load decreases to the point where it no longer demands the full 1 amp charging rate. This is the crossover point where the power supply goes into the constant voltage mode.

#### 3-1 Front Panel

②② Power switch: ON/OFF the power input.

① V LED display: Indicates the MASTER output voltage.

③ V LED display: Indicates the SLAVE output voltage.

② A LED display: Indicates the MASTER output current.

④ A LED display: Indicates the SLAVE output current.

⑤ Voltage control: for adjustment of the output voltage of the MASTER supply. Also functions as adjustment control for the maximum output voltage of the SLAVE supply when either parallel or series tracking operation.

⑦ Voltage control: for adjustment of the output voltage of the SLAVE supply when the independent operation.

⑥ Current control: for adjustment of the output current of the MASTER supply. Also functions as adjustment control for the maximum output voltage of the SLAVE supply when either parallel or series tracking operation.

⑧ Current control: for adjustment of the output current of the SLAVE supply.

⑩ C.V indicator: lights when the MASTER supply is in the constant voltage operation, in either the Series or Parallel Tracking mode, both the MASTER AND SLAVE supplies are in the constant voltage operation.

⑫ C.V indicator: lights when the SLAVE supply is in the constant voltage operation.

⑪ C.C. indicator: lights when the MASTER supply is in the constant current operation.

⑬ C.C. indicator: lights when the SLAVE supply is in the constant current operation.

Also lights when the TRACKING PARALLEL mode is selected.

⑨ Over load indicator: lights when load on 5 volt supply becomes too large.

⑭ ⑮ TRACKING Mode Switches:

Two push-button switches that select INDEPENDENT mode, series tracking mode, or parallel tracking mode as follows:

- a. When both switches are disengaged (out), the unit is in the INDEPENDENT mode and the MASTER and SLAVE power supplies are completely independent from one another.
- b. When the left switch is engaged (in) and the right switch is disengaged (out), the unit is in the TRACKING SERIES mode. In this mode, maximum voltage of both supplies is set using the MASTER VOLTAGE controls (voltage at output terminals of the SLAVE supply tracks the voltage at the output terminals of the MASTER supply). Also, in this mode of operation the positive terminal (red) of the SLAVE supply is connected to the negative terminal (black) of the MASTER supply.

This allows the two supplies to be used as one 0 to double rating voltage supply.

- c. When both switches are engaged (in), the unit is in the TRACKING PARALLEL mode. In this mode the MASTER and SLAVE supplies are wired together in parallel and both the maximum current and voltage are set using the MASTER controls.

The MASTER and SLAVE outputs can be used as two individual (but tracking) power supplies or just the MASTER output can be used as a 0 to rating voltage supply with a 0 to double rating current capability.

⑩⑥ " + " : output terminal: positive polarity output terminal for the MASTER supply.

⑩⑨ " + " : output terminal: positive polarity output terminal for the SLAVE supply.

⑩⑦ " GND " terminal: Earth and chassis ground.

⑩⑩ " GND " terminal: Earth and chassis ground.

⑩⑧ " - " : output terminal: Negative polarity output terminal for the MASTER supply.

⑩① " - " : output terminal: Negative polarity output terminal for the SLAVE supply.

⑩③ " + " : output terminal: positive polarity output terminal for 5V supply.

⑩④ " - " : output terminal: Negative polarity output terminal for 5V supply.

⑩⑨ Output ON/OFF switch: DC power supply output when switch is engaged (in). And when output is off, both the voltage and current can be adjusted before the output is resumed.

⑩⑧ Output indicator: lights when switch is engaged (in).

### 3-2 Rear Panel

⑩⑤ Fuse holder

⑩⑥ Power cord

⑩⑦ Fan

⑩⑩ AC voltage select switch

## 4. OPERATION INSTRUCTIONS

### 4-1 Precaution

(1). AC input

AC input should be within the range of line voltage  $\pm 10\%$  50/60Hz.

(2). Installation

Avoid using the supply in a place where the ambient temperature exceeds  $40^{\circ}\text{C}$ . The heat sink located at the rear of the supply must have sufficient air space for radiation.

Fig.3-2 Rear Panel

