



ABW 32

Withstand the harshest working conditions, Aqua washdown scales are IP67 and feature a large removable stainless steel weighing pan. Ideal for food production, catering and industrial environments, precision load cell technology enables improved performance and greater efficiency during weighing and counting tasks. The dual 20mm-high digit front and rear displays enhance visibility and productivity for the user. Checkweighing is simple, with separate high, ok and low coloured LED indicators that change colour to alert the operator if a sample is under, over or within preset limits. Power is supplied by AC adapter or rechargeable battery, and auto power-off conserves battery life.

**Get the Aqua wet without worry, the IP67 scale performs effortlessly and accurately no matter how rigorous the application**



## Features

- IP67-rated for protection against water and dust
- External calibration allows for verification and adjustment with weights
- Sealed keypad protects against dirt and spills
- Overload protection helps prevent damage to internal components
- Solid ABS housing is durable for industrial use
- Heavy-duty rubber feet ensure stability of unit
- Bright LED display for easy viewing in most environments
- Checkweighing LEDs clearly show under, over and within acceptable limits
- Parts counting optimization automatically refines piece weight as parts are added
- Zero-tracking feature ensures display returns to zero reading
- The auto power-off feature conserves battery life
- Rechargeable battery included for operation almost anywhere
- AC adapter included

## Applications

- Weighing
- Parts counting
- Percentage weighing
- Checkweighing

### About ADAM:

For nearly 50 years, professionals worldwide have relied on Adam Equipment for an extensive selection of dependable and affordable weighing equipment. Adam provides the right balance of speed, performance and value.

## Product Details

Model	ABW 4	ABW 8	ABW 16	ABW 32
Capacity	9lb / 4kg	18lb / 8kg	35lb / 16kg	70lb / 32kg
Readability	0.001lb / 0.5g	0.002lb / 1g	0.005lb / 2g	0.01lb / 5g
Repeatability	0.002lb / 1g	0.005lb / 2g	0.01lb / 5g	0.02lb / 10g
Linearity	0.002lb / 1g	0.005lb / 2g	0.01lb / 5g	0.02lb / 10g
Pan Size	9.6"x7.1" / 245x180mm			11.8"x8.3" / 300x210mm
Weighing Units	g, kg, lb, oz, lb:oz			
Stabilization Time (sec.)	1			
Calibration	External			
Display	LED with 0.8" / 20mm high digits			
Power Supply	12VDC 800mA adapter, Internal rechargeable battery			
Operating Temperature	0° to 40°C / 32° to 104°F			
Housing	ABS plastic			
Overall Dimensions	10.0"x11.4"x4.1" / 255x290x105mm			11.8"x12.2"x4.1" / 300x310x105mm
Net Weight	5.5lb / 2.5kg			

## Accessories

Item number	Description
3022014061	In-use cover
2020014062	In-use cover (pack of 5)
2020014063	In-use cover (pack of 10)
3002014371	Hard carrying case
303149759	Vegetable Scoop (complete with fitting to scales)
303149760	Confectionery Scoop (complete with fitting to scales)
700660290	Calibration certificate

### Key Accessories



**Scoops**  
Metal scoops are designed to make portioning and food measurement easy. Two sizes available: small and large.



**Hard Carrying Case**  
Allows the Aqua to be placed inside to protect it during transportation. The hard shell case is durable and comes with a lock so that you can secure the scale in the case as needed. Die cut foam insert provides room for the scale, power supply and top pan.

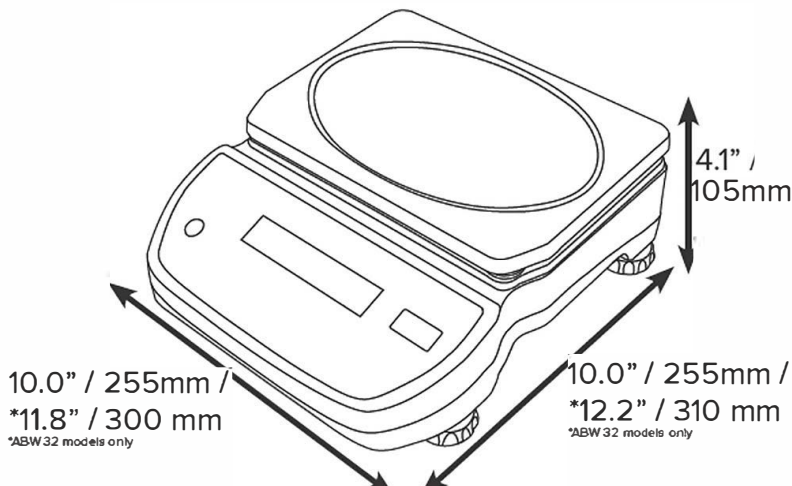

Supplied by: