

AMPROBE[®]

ACD-3300 IND
ACDC-3400 IND

**CAT IV Industrial True
RMS Clamp Meters**

Users Manual



ACD-3300 IND ACDC-3400 IND

CAT IV Industrial True RMS
Clamp Meters

Users Manual

Limited Warranty and Limitation of Liability

Your Amprobe product will be free from defects in material and workmanship for 1 year from the date of purchase. This warranty does not cover fuses, disposable batteries or damage from accident, neglect, misuse, alteration, contamination, or abnormal conditions of operation or handling. Amprobe's warranty obligation is limited, at Amprobe's option, to refund of the purchase price, free of charge repair, or replacement of a defective product . Resellers are not authorized to extend any other warranty on Amprobe's behalf. To obtain service during the warranty period, return the product with proof of purchase to an authorized Amprobe Test Tools Service Center or to an Amprobe dealer or distributor. See Repair Section for details. This warranty is your only remedy . All other warranties - whether express, implied or statutory - including implied warranties of fitness for a particular purpose or merchantability, are hereby excluded. Neither Amprobe nor its parent company or affiliates shall be liable for any special, indirect, incidental or consequential damages or losses, arising from any cause or theory. Since some states or countries do not allow the exclusion or limitation of an implied warranty or of incidental or consequential damages, this limitation of liability may not apply to you.

Repair

All test tools returned for warranty or non-warranty repair or for calibration should be accompanied by the following: your name, company's name, address, telephone number, and proof of purchase. Additionally, please include a brief description of the problem or the service requested and include the test leads with the meter. Non-warranty repair or replacement charges should be remitted in the form of a check, a money order, credit card with expiration date, or a purchase order made payable to Amprobe® Test Tools.

In-Warranty Repairs and Replacement – All Countries

Please read the warranty statement and check your battery before requesting repair. During the warranty period any defective test tool can be returned to your Amprobe® Test Tools distributor for an exchange for the same or like product.

Non-Warranty Repairs and Replacement – US and Canada

Non-warranty repairs in the United States and Canada should be sent to a Amprobe® Test Tools Service Center. Call Amprobe® Test Tools or inquire at your point of purchase for current repair and replacement rates.

Non-Warranty Repairs and Replacement – Europe

European non-warranty units can be replaced by your Amprobe® Test Tools distributor for a nominal charge.

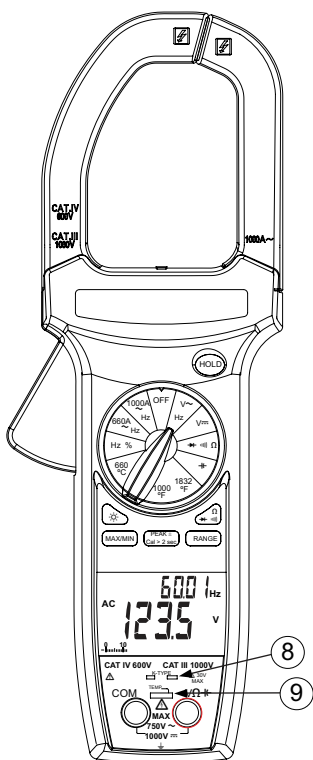

ACD-3300 IND

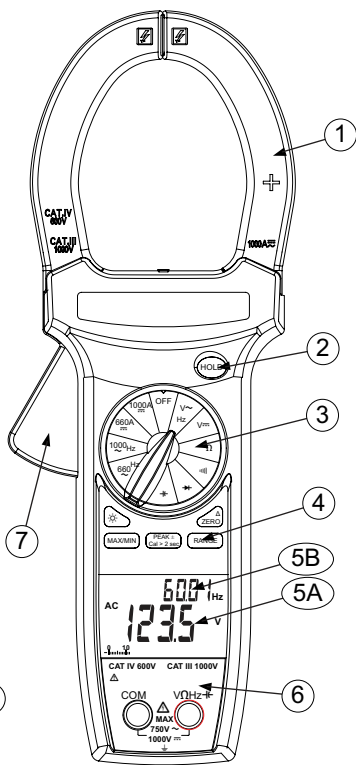

ACDC-3400 IND

- ❶ Jaws for Current tests
- ❷ HOLD button
- ❸ Function selection knob
- ❹ Auxiliary feature buttons
- ❺A Primary LCD display
- ❺B Secondary LCD display
- ❻ Input jacks for functions other than Current
- ❼ Trigger to open the current jaws
- ❽ Temperature Input Jacks
- ❾ Temperature Slide Knob













ACD-3300 IND / ACDC-3400 IND

CAT IV Industrial True RMS Clamp Meters

CONTENTS

Symbols.....	5
Safety Information.....	5
⚠ Warnings and Precautions.....	5
Unpacking and Contents.....	6
Introduction.....	6
AUXILIARY FEATURES.....	6
PEAK+/- Push button.....	6
MAX/MIN Button.....	6
⚠ ZERO (Relative) Measurements (ACDC-3400 IND only).....	7
HOLD Button.....	7
RANGE Button.....	7
☀ Backlight Push Button.....	7
Auto Power Off (APO).....	7
Operation.....	7
Measuring DC Voltage (see Fig. 2).....	7
Measuring AC Voltage (See Fig. 2).....	7
AC Current Measurement (See Fig. 3).....	7
DC Current Measurement (ACDC-3400 IND only) (See Fig. 3).....	7
Frequency Measurement / % Duty Cycle (see Fig. 2).....	8
Capacitance Measurement (see Fig. 4).....	8
Resistance (See Fig. 5).....	8
Continuity Testing (See Fig. 5).....	8
Diode Testing (See Fig. 5).....	8
Temperature Measurement (ACD 3300 IND only) (See Fig. 6).....	9
Maintenance and Repair.....	9
Battery Replacement (see Fig. 7).....	9
Specifications.....	9
General.....	9
Electrical.....	10

SYMBOLS

	Battery		Refer to the manual
	Double insulated		Dangerous Voltage
	Direct Current		Earth Ground
	Alternating Current		Audible tone
	Conforms to relevant Australian standards.		Complies with EU directives
	Do not dispose of this product as unsorted municipal waste.		Underwriters Laboratories. [Note: Canadian and US.]
	Application around and removal from hazardous live conductors is permitted		

SAFETY INFORMATION

- The ACD-3300 IND and ACDC-3400 IND Digital Clamp meters conform to EN61010-1:2001; EN61010- 2-032:2002; CAT IV 600 V, CAT III 1000 V, class II and pollution deg. 2. EMC: conforms to EN61326-1.
- Each instrument is EN61010-1 certified for Installation Category IV (600V). It is recommended for primary supply lines, overhead lines and cable systems. and in distribution level and fixed installations, as well as lesser installations.
- Do not exceed the maximum overload limits per function (see specifications) nor the limits marked on the instrument itself. Never apply more than 1000 Vdc/750 Vac rms between the test lead and earth ground.

Warnings and Precautions

- Before and after hazardous voltage measurements, test the voltage function on a known source such as line voltage to determine proper meter functioning.
- Disconnect the test leads from the test points before changing meter functions.
- Disconnected from the meter's test leads before measuring current.
- Inspect the Clammeter, test leads and accessories before every use. Do not use any damaged part.
- Never ground yourself when taking measurements. Do not touch exposed circuit elements or test probe tips.
- Do not operate the instrument in an explosive atmosphere.
- To reduce the risk of fire or electric shock, do not expose this product to rain or moisture.
- The meter is intended only for indoor use. To avoid electrical shock hazard, observe the proper safety precautions when working with voltages above 60 VDC, 42.4 Vpk, or 30 VAC rms. These voltage levels pose a potential shock hazard to the user.
- Before and after hazardous voltage measurements, test the voltage function on a known source such as line voltage to determine proper meter functioning.
- Keep your hands/fingers behind the hand/finger barriers (of the meter and the test leads) that indicate the limits of safe access of the hand-held part during measurement.
- Inspect test leads, connectors, and probes for damaged insulation or exposed metal before using the instrument. If any defects are found, replace them immediately.
- This Clamp-on meter is designed to apply around or remove from un-insulated hazardous live conductors. Individual protective equipment must be used if hazardous live parts of the installation could be accessible.

- Exercise extreme caution when: measuring voltage >20 V // current >10 mA // AC power line with inductive loads // AC power line during electrical storms // current, when the fuse blows in a circuit with open circuit voltage >1000 V // servicing CRT equipment.
- Remove test leads before opening the case to change the battery.
- Disconnect circuit power and discharge all high-voltage capacitors before testing resistance, continuity, diodes, or capacitance.
- To avoid false readings, which could lead to possible electric shock or personal injury, replace the batteries as soon as the low battery indicator (🔋) appears.
- To avoid electric shock hazard, do not use the HOLD  mode to determine if a circuit is live. Unstable readings will not be captured and displayed.

CAUTION

- For non-invasive ACA current measurements, clamp the jaws around only one single conductor of a circuit for load current measurement. More than 1 conductor will cause false readings.

UNPACKING AND CONTENTS

Your shipping carton should include:

- 1 ACD-3300 IND or ACDC-3400 IND
- 1 Test lead set
- 1 9 V battery (installed)
- 1 Users Manual
- 1 Carrying Case
- 1 type-K thermocouple (Model ACD-3300 IND only)

If any of the items are damaged or missing, immediately return the complete package to the place of purchase for an exchange.

INTRODUCTION

The ACD-3300 IND and ACDC-3400 IND True RMS Clamp-On meters are autoranging to 1000 ACA and 750 VAC / 1000 VDC. Their features include AC / DC voltage, AC / DC current (ACDC-3400 IND), Frequency, Duty Cycle, Diode, Resistance, Capacitance, Continuity tests plus Relative (ACDC-3400 IND). Model ACD-3300 IND also measures temperature to 1000°C (1832°F)

AUXILIARY FEATURES

PEAK+/- Push button

It is used to record the peak + and - peak values for AC voltage and AC current measurements.

Make the normal AC measurement and press the PEAK button. The PEAK value is displayed on the secondary display and the actual value displayed on the primary display. This function range locks on the normal range being used and may display OL if the input exceeds the range maximum.

Note: If the PEAK ± button is pressed >2 sec, the PEAK function will enter to calibration mode, the LCD will show "CAL" and the internal buffer will remember the internal offset voltage when back in the measure mode. To exit the 'CAL' mode, turn the meter OFF.

MAX/MIN Button

The "MAX" displays the maximum value of a set of measurements. The "MIN" displays the minimum value of a set of measurements. The "MAX/MIN" appears and flashes in the LCD to display the value that is being measured. To exit, press MAX/MIN button for more than 2 seconds

Δ ZERO (Relative) Measurements (ACDC-3400 IND only)

The Relative mode displays the difference between the actual reading and a reference value. It may be used with any function or range. To make a relative measurement first establish a reference value by measuring a value and then pressing the **Δ** button after the reading has stabilized. This stores the measured value as the reference and sets the display to zero. The meter subtracts the reference value from subsequent measurements and displays this difference as the relative value. Measurement values greater than the reference value will be positive and values less than the reference value will be negative. To exit the Relative Mode, Press and hold the **Δ** button for 2 seconds.

This feature should be used to set DC zero for DC amps.

HOLD Button

Data hold freezes the reading present on the LCD at the moment the button is pressed. To use this menu feature set up the meter for the type of measurement and range desired. Connect the test leads to the circuit / component to be measured, then press HOLD push button. The LCD reading will freeze and display "HOLD." You may now remove the test leads and the reading will not change until you press Hold again.

RANGE Button

Allows the user to select the range of a function that does not show 'RANGE' on the LCD.

☀ Backlight Push Button

Turns the back light On or OFF.

Auto Power Off (APO)

This meter will automatically turn the power off after 30 minutes. To disable the APO, set the meter to off position, press and hold the (RANGE) or (MAX/MIN) button while turning the rotary knob to the desired range position. Release the button when LCD displays normally. Note "APO" annunciator is missing from the LCD.

OPERATION

Measuring DC Voltage (see Fig. 2)

1. Set the Function Switch to **V^{DC}**.
2. Connect the test leads: Red to **+**, Black to **COM**.
3. Connect the test probes to the circuit test points.
4. Read the display and if necessary, correct any overload (**OL**) conditions.

Measuring AC Voltage (See Fig. 2)

Caution: For voltages below 0.2V, frequency reading may be unstable.

1. Set the Function Switch to **V^{AC}**.
2. Connect the test leads: Red to **+**, Black to **COM**.
3. Connect the test probes to the circuit test points.
4. Read the voltage on the primary display and the frequency on the secondary display and if necessary, correct any overload (**OL**) conditions.

AC Current Measurement (See Fig. 3)

Caution: For currents below 10A, frequency reading may be unstable.

1. Set the Function Switch to **A^{AC}** position.
2. Open spring-loaded clamp by pressing the lever on left side of meter.
3. Position clamp around one wire or conductor and release the clamp lever. Wire should be center inside the jaws.
4. Read the current on the primary display and the frequency on the secondary display and if necessary, correct any overload (**OL**) conditions.

DC Current Measurement (ACDC-3400 IND only) (See Fig. 3)

1. Set the Function Switch to **A^{DC}** position.

2. Press the Δ button to null out the DC amps offset.
3. Open spring-loaded clamp by pressing the lever on left side of meter.
4. Position clamp around one wire or conductor and release the clamp lever. Wire should be center inside the jaws.
5. Read the displayed value.

Frequency Measurement / % Duty Cycle (see Fig. 2)

1. Select the "Hz" position.
2. Connect the test leads: Red to +, Black to COM.
3. Connect the test probes to the circuit test points.
4. Read the frequency on the primary display and the Duty cycle on the secondary display, and, if necessary, correct any overload (OL) conditions.

Capacitance Measurement (see Fig. 4)

Note: When the capacitor to be tested is connected and LCD indicates "di .c", means there is voltage on the capacitor and needs to be discharged before testing.

1. Select the "F" position.
2. Connect the test leads: Red to +, Black to COM.
3. Connect the test probes to the circuit test points.
4. Read the display and if necessary, correct any overload (OL) conditions.

Δ CAUTION

Using the Resistance or Continuity function in a live circuit will produce false results and may damage the instrument. In most cases the suspected component must be disconnected from the circuit to obtain an accurate measurement reading.

Resistance (See Fig. 5)

1. Set the Function Switch to Ω . Use the ' $\Omega \rightarrow \text{diode}$ ' button to select the resistance test (ACD-3300 IND only).
2. Connect the test leads: Red to +, Black to COM.
3. Turn off power to the circuit being measured. Never measure resistance across a voltage source or on a powered circuit.
4. Discharge any capacitors that may influence the reading.
5. Connect the test probes across the resistance.
6. Read the display. If OL appears on the highest Range, the resistance is too large to be measured or the circuit is an open circuit.

Continuity Testing (See Fig. 5)

1. Set the Function Switch to diode . Use the ' $\Omega \rightarrow \text{diode}$ ' button to select the diode test (ACD-3300 IND only).
2. Connect the test leads: Red to +, Black to COM.
3. Turn off power to the circuit being measured.
4. Discharge any capacitors that may influence the reading.
5. Connect the test probes across the resistance or the two points of test.
6. Listen for the tone that indicates continuity (< 30 Ω).

Diode Testing (See Fig. 5)

1. Set the Function knob to the " \rightarrow " position. Use the ' $\Omega \rightarrow \text{diode}$ ' button to select diode test (ACD-3300 IND only).
2. Connect the red test lead to the "V Ω " jack and the black test lead to the "COM" jack.
3. Turn off power to the circuit under test. External voltage across the components causes invalid readings.
4. Touch probes to the diode. A forward-voltage drop is about 0.6V (typical for a silicon diode).

- Reverse probes. If the diode is good, "OL" is displayed. If the diode is shorted, "0.00" or another number is displayed.
- If the diode is open, "OL" is displayed in both directions.
- Audible Indication: Less than 30 Ω .

Temperature Measurement (ACD 3300 IND only) (See Fig. 6)

- Verify the location being tested is not electrically energized.
- Set the Function Switch to $^{\circ}\text{C}$ and range or $^{\circ}\text{F}$ and range.
- Move the slide knob to the TEMP position. Insert the thermocouple plug matching the slot widths.
- Connect the thermocouple bead to the test point.
- Read the display. If **OL** appears on the display, the temperature is too large to be measured or the thermocouple is open.

Note: The test leads must be removed to move the slide plate to allow the thermocouple to be inserted.

MAINTENANCE AND REPAIR

If there appears to be a malfunction during the operation of the meter, the following steps should be performed in order to isolate the cause of the problem:

- Check the battery.
- Review the operating instructions for possible mistakes in operating procedure.
- Inspect and test the test leads for a broken or intermittent connection.

Except for the replacement of the battery or test probes, repair of the multimeter should be performed only by a Factory Authorized Service Center or by other qualified instrument service personnel. The front panel and case can be cleaned with a mild solution of detergent and water. Apply sparingly with a soft cloth and allow to dry completely before using. Do not use aromatic hydrocarbons or chlorinated solvents for cleaning.

Battery Replacement (see Fig. 7)

Warning

To prevent electrical shock or meter damage, disconnect the meter's test leads from any circuit and the meter, then turn the meter off before removing the battery cover. Battery replacement should be performed in a clean environment and with appropriate care taken to avoid contaminating the meter's interior components.

- Remove the screws and lift the battery cover.
- Replace the battery with the same type, 9-volt battery.

Note polarity of the battery.

- Replace the rear case and screws.

SPECIFICATIONS

General

Display: 3¾ digit liquid crystal display (LCD) (6600 count) with a 66-segment analog bar-graph.

Polarity: Automatic, positive implied, negative polarity indication.

Over range: (OL) or (-OL) is displayed.

Zero: Automatic.

Low battery indication: The "**+■**" is displayed when the battery voltage drops below the operating level.

Auto power off: Approx. 30 minutes.

Backlight: Backlight auto-off approx. 60 sec.

Measurement rate: 2.8 times per second, nominal.

Analog bar-graph: 28 times per second.

Operating environment: 0°C to 50°C (32°F to 122°F) at < 70% R.H.

Storage temperature: -20°C to 60°C (-4°F to 140°F) at < 80% R.H. with battery removed from meter.

Temperature Coefficient: 0.1 × (specified accuracy) per °C. (0°C to 18°C, 28°C to 50°C).

Environmental: 2000m (6561.7 Feet), Indoor use.

Jaw opening capability: 57 mm (2.0 in) conductor.

Power: Single standard 9-volt battery, NEDA 1604, JIS 006P, IEC 6F22.

Battery life: typically 75 hours with carbon-zinc; 150 hour with alkaline.

Dimensions:

ACDC-3400 IND: 281 x 108 x 53 mm (11.1 x 4.3 x 2.1 in.)

ACD-3300 IND: 279 x 103 x 53 mm (11 x 4.1 x 2.1 in.)

Weight:

ACDC-3400 IND: 559 gm (1.23 lb.)

ACD-3300 IND: 500 gm (1.10 lb.)

Safety: LVD Meets EN61010-1:2001 and EN61010-2-032:2002, CAT III 1000V, CAT IV 600V, class II and pollution degree 2

CE EMC: EN 61326-1:2006 This product complies with requirements of the following European Community Directives: 2004/108/EC (Electromagnetic Compatibility) and 2006/95/EC (Low Voltage) as amended by 93/68/EEC (CE Marking). However, electrical noise or intense electromagnetic fields in the vicinity of the equipment may disturb the measurement circuit. Measuring instruments will also respond to unwanted signals that may be present within the measurement circuit. Users should exercise care and take appropriate precautions to avoid misleading results when making measurements in the presence of electronic interference.

Electrical

Accuracy: Stated accuracy at 23°C ± 5°C, < 75% RH

DC VOLTS

Ranges	Accuracy
660.0 mV, 6.600 V, 66.00 V, 660.0 V, 1000 V	± (0.5% rdg + 2 dgts)

Input impedance: 660 mV: >100 MΩ; 6.6 V: 10 MΩ; 66 V to 1000 V: 9.1 MΩ

Overload protection: 1000 VDC or 750 VAC rms

AC VOLTS TRUE RMS

Ranges:	Frequency	Accuracy
660.0 mV	50 to 100 Hz	± (1.5% rdg + 8 dgts)
6.600V, 66.00V	50 to 500 Hz	± (1.5% rdg + 8 dgts)
660.0V, 750V	50 to 500 Hz	± (1.5% rdg + 8 dgts)
Frequency **	50 to 1 kHz	± (0.1% rdg + 5 dgts)

Peak Hold:

Ranges:	Frequency	Accuracy
66.00V, 660.0V, 750V	50 to 500 Hz	± (3.0% rdg + 200 dgts)

** Frequency: 10% to 100% of voltage range

AC coupled TRMS: 5% to 100% of range

Crest factor: ≤ 3

Input impedance: 660 mV: >100 MΩ; 6.6 V: 10 MΩ; 66 V to 750 V: 9.1 MΩ

Overload protection: 1000 VDC or 750 VAC rms

AC CURRENT TRUE RMS

Ranges:	Frequency	Accuracy
66.00A*	50 to 60 Hz	± (2.0% rdg + 10 dgts)
66.00A*	61 to 400 Hz	± (3.0% rdg + 10 dgts)
660.0A	50 to 60 Hz	± (2.0% rdg + 10 dgts)
660.0A	61 to 400 Hz	± (3.0% rdg + 10 dgts)
1000 A	50 to 60 Hz	± (2.5% rdg + 10 dgts)
1000 A	61 to 400 Hz	± (3.5% rdg + 10 dgts)
Frequency**	50 to 1kHz	± (0.1% rdg + 5 dgts)

Peak Hold:

Ranges:	Frequency	Accuracy
66.00A*, 660.0A, 1000A	50 to 400 Hz	± (3.0% rdg + 200 dgts)

* ACD-3300 IND only

** Frequency: 10% to 100% of current range

AC coupled TRMS: 5% to 100% of range

Crest factor: ≤ 3

Overload protection: 1000A AC

DC CURRENT (ACDC-3400 IND only)

Range	Accuracy
660.0A	± (2.0% rdg + 5 dgts)
1000A	± (3.0% rdg + 5 dgts)

Overload protection: 1000A DC

RESISTANCE

Range	Accuracy
660.0 Ω , 6.600k Ω	\pm (1.0% rdg + 5 dgts)
66.00k Ω , 660.0k Ω	
6.600M Ω :	\pm (2.0% rdg + 5 dgts)
66.00M Ω :	\pm (3.5% rdg + 5 dgts)

Open circuit volts: -1.2 Vdc typical , (-3.5 Vdc on 660 Ω range)

Overload protection: 1000 VDC or 750 VAC rms

CAPACITANCE

Range	Accuracy
6.600nF, 660nF	\pm (3.0% rdg + 20 dgts)
66nF, 6.600 μ F, 66.00 μ F,660.0 μ F	\pm (3.0% rdg + 10 dgts)
6.6 mF	\pm (5.0% rdg + 10 dgts)

Overload protection: 1000 VDC or 750 VAC rms

TEMPERATURE (ACD-3300 IND only)

Range	Accuracy
0.0°C to 400.0°C	\pm (1.0% + 1°C)
-35.0°C to 0.0°C, 400°C to 1000°C	\pm (2.0% + 3°C)
32.0°F to 750.0°F	\pm (1.0% + 2°F)
-30.0°F to 32.0°F, 750°F to 1832°F	\pm (2.0% + 6°F)

Sensor type: K-type thermocouple

Overload protection: 30 V Max

DIODE TEST

Test current: 0.8 mA (approximate)

Accuracy: \pm (1.5% rdg + 5 dgts)

Open circuit volts: 3.2 Vdc typical

Audible indication: < 0.03 V

Overload protection: 1000 VDC or 750 VAC rms

CONTINUITY

Ranges: 660.0 Ω

Audible indication: < 30 Ω

Response time: 500 ms

Overload protection: 1000 VDC or 750 VAC rms

FREQUENCY (Auto ranging)

Range	Accuracy
66.00 Hz, 660.0 Hz, 6.600k Hz, 66.00 kHz, 660.0 kHz, 1.000 MHz	\pm (0.1% rdg + 5 dgts)

Sensitivity: 10 Hz to 1 MHz: > 3.5 V rms

Minimum pulse Width: >1 μ s

Duty cycle limits: >30% and <70%

% DUTY CYCLE

Range: 5.0 % to 95.0 %

Resolution: 0.1 %

Minimum Pulse Width: >10 μ s

Frequency range: 40 Hz to 20 kHz

Accuracy (5V logic): \pm (2% rdg + 10 dgts)

Overload protection: 1000 VDC or 750 VAC rms

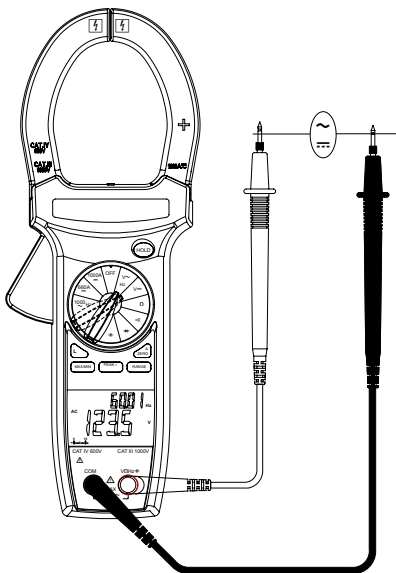

Fig 2. Voltage \ Frequency \ Duty Cycle

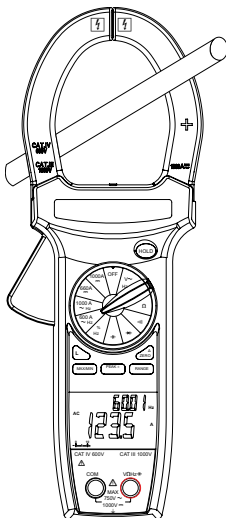

Fig 3. Current

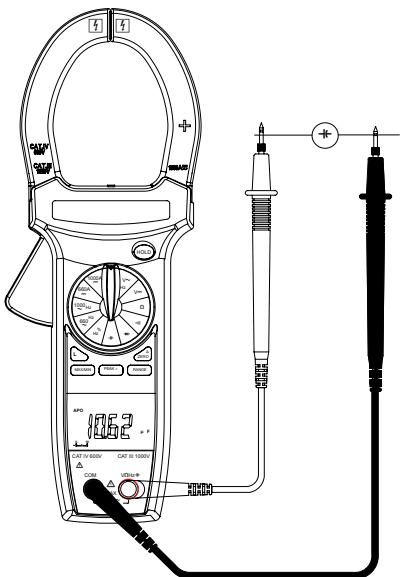

Fig 4. Capacitance

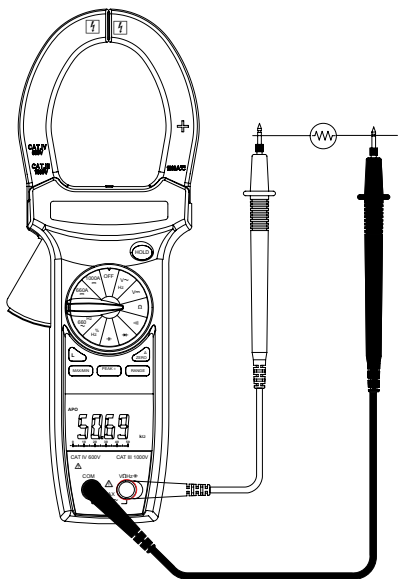

Fig 5. Resistance \ Continuity\Diode

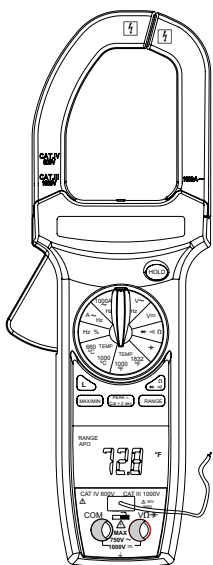

Fig 6. Temperature (ACD-3300 IND only)

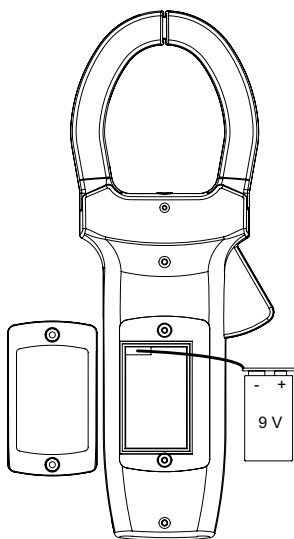

Fig 7. Battery Replacement