

Instruction Manual

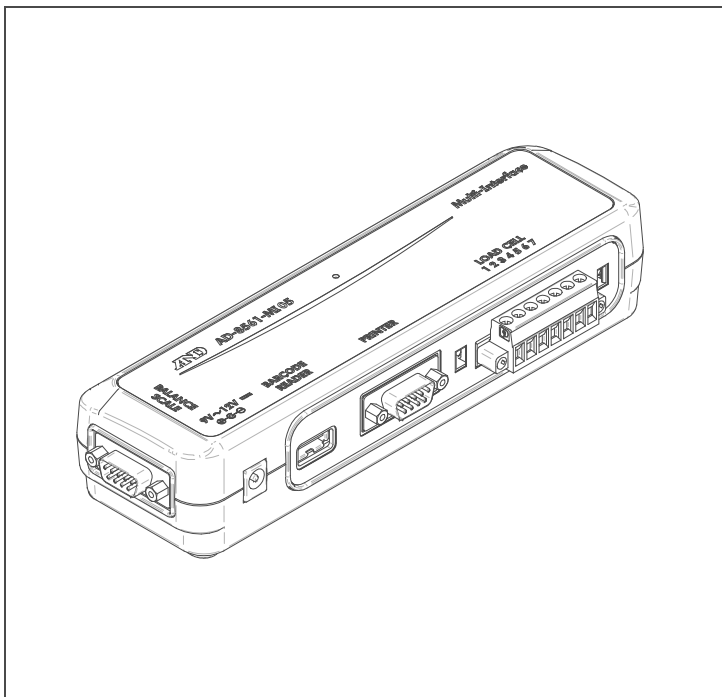

1WMPD4004601

Safety Precautions

This manual describes the conditions to follow so that you can prevent damages to yourself or anyone else and handle the product safely. To prevent accidents due to inappropriate handling, this manual and the product contain the following warning signs. The meanings of the warning signs are as follows.

| | |
|--|--|
| | Warning A potentially hazardous situation which, if not avoided, could result in death or serious injury. |
| | Caution A potentially hazardous situation which, if not avoided, may result in personal injury or property damage. |

- No parts of this manual may be reproduced without permission. This manual may not be copied, modified, or translated without the written permission of A&D Company, Limited.
- The contents of this manual are subject to change without notice.
- Please contact A&D if you notice any uncertainty, errors, omissions, etc. in this manual.
- A&D Company, Ltd. bears no liability for direct, indirect, special, or consequential damages due to the operation of this product, even if advised of the possibility of such damage regardless of (3) above.

© 2022 A&D Company, Limited

Caution

- Do not disassemble the AD-8561. Disassembling may cause damage to the product. Damage caused by disassembling will not be covered by the warranty.
- If a problem has occurred and you cannot resolve it, stop using the AD-8561.

1. Introduction

This manual describes how the AD-8561 multi interface works and how to get the most out of it in terms of performance. Read this manual completely before using the AD-8561. For the information on the AD-8561 and the related products, please refer to the A&D website (<https://www.aandd.co.jp/>).

2. About the AD-8561

2-1. Features

The following operations are enabled when the AD-8561 is connected to the RS-232C output on the GC-series (hereinafter called 'the counting scale').

- Transmitting and receiving data from D-sub 9 pin (between the counting scale and a connected device such as a printer)
- Sending texts to the counting scale from USB Type-A with a barcode reader or keyboard (from a barcode reader/keyboard to the counting scale)
- Sending weighing data from an external scale connected to the terminal block to the counting scale (from an external scale to the counting scale).

Each color of the LED lights shown below indicates different status.

| LED Color | Status of the AD-8561 | Communication available |
|-------------------|--|--|
| Blue | Activating | Communication available |
| White | A barcode reader or keyboard is connected (HID setting: key mode) | Communication available |
| Yellow | A barcode reader or keyboard is connected (HID setting: command mode) | Communication available |
| Yellow (blinking) | An input that exceeds 64 digits is received from a keyboard (Command mode/Refer to '5-2. USB Connector') | Restart the device. |
| Red (blinking) | Not-supported devices connected to USB Type-A | Immediately remove the USB drive |
| Red | Error | Communication unavailable Restart the device. |

(For how to restart the device, refer to '4-1. Connection to Power Supply')

2-2. Precautions for Use

- The power for AD-8561 can be supplied from the counting scale with an accessory cable. When another cable is used, an AC adapter for power supply may be required. (Refer to '4-1. Connection to Power Supply')
- Make sure to check the rating of the AC adapter before attaching it. Inappropriate power supply may cause malfunction or damage to the internal circuitry.
- Magnets are used for simple fixation.
*When there is any magnetically sensitive device such as a balance nearby, they can affect the device. In this case, remove the magnets from the AD-8561.

<How to remove the magnets for attaching the interface>

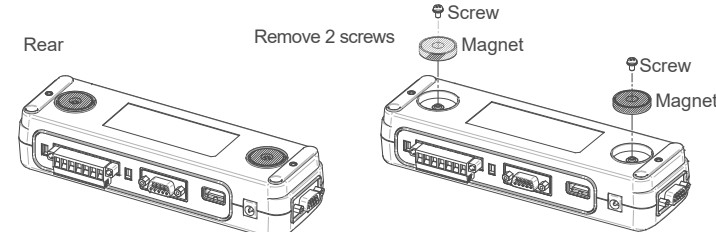

- Magnets are not strong enough to secure the interface to wall. To attach to a wall, first attach the AD-8561 to a GC-14, an option for the counting scale, with screws, and then attach the GC-14 to a wall (with screws or by hanging it on a wall). For the details, refer to the instruction manual for the GC-14.

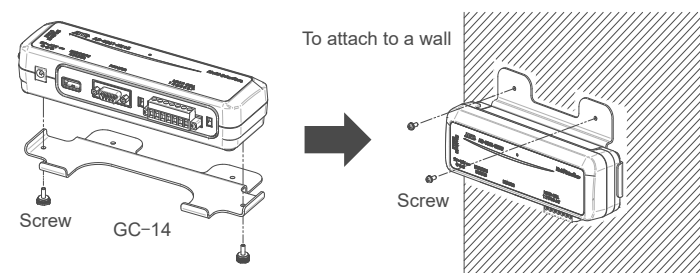

3. Part Names and Accessories

3-1. Main Unit

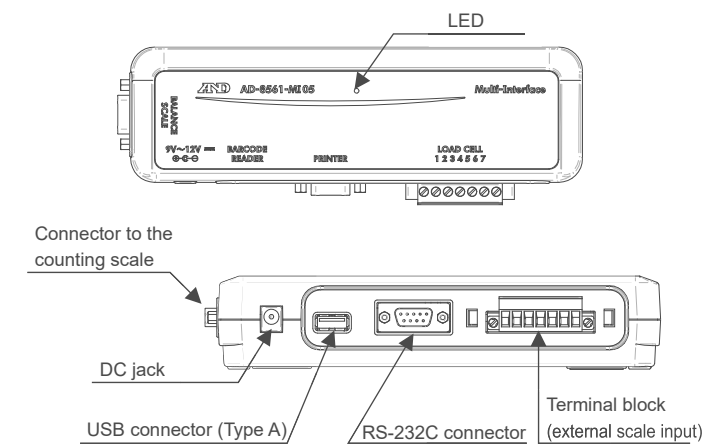

3-2. Accessories

- Instruction manual (This manual)
- Cable (1m, D-sub 9 pin, female-female, for connecting to the counting scale)
- Terminal block cover

<How to attach the terminal cover>

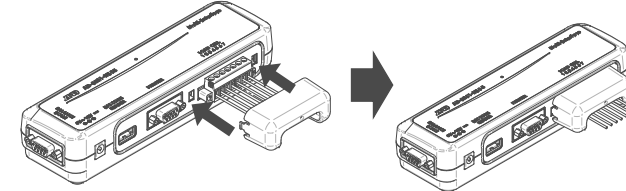

Plug in and secure to the holes on the right and left sides of the terminal

4. Connection to Other Device

4-1. Connection to Power Supply

- Supply power from the counting scale by connecting an accessory cable to the connector on the AD-8561 (use a D-sub 9 pin).

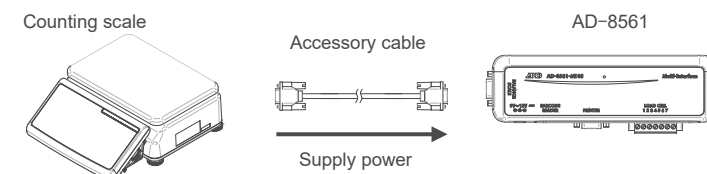

- When the accessory cable is not used, an AC adapter should be used to supply power from the DC jack.
 - When using a commercially available cable to which the 9th pin of the connector is not connected
 - When communicating between the counting scale and AD-8561 at a distance longer than 1m
- * A cable longer than 1m, which is optionally available, is not connected to the 9th pin of the connector and therefore requires power supply from an AC adapter. (Refer to (3) in '8-3. Optional Devices')

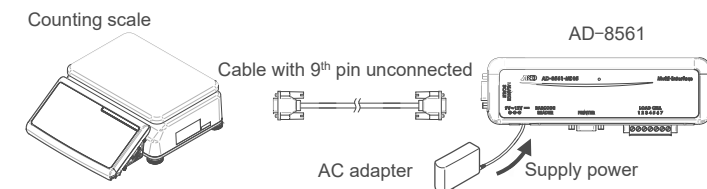

- Make sure to check the specifications when using an AC adapter. An AC adapter with a center negative plug that outputs DC 9 to 12V is usable.
- The main unit is activated when it is connected to the counting scale or when an AC adapter is inserted into the DC jack. Once it is activated, a blue LED light is turned on.
- To restart the interface, remove the cable or AC adapter and confirm that the LED light is turned off. Then, reconnect it to turn the power on.

4-2. Connected Devices

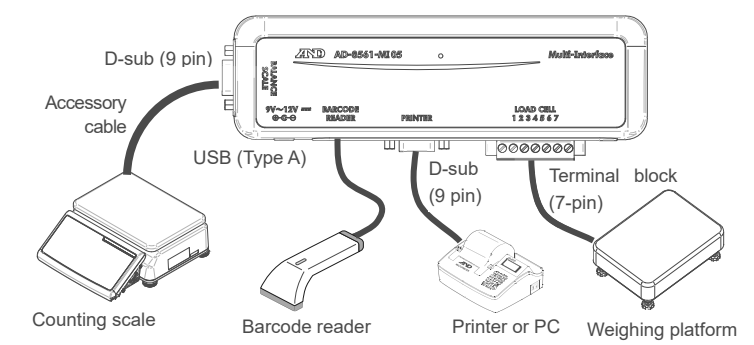

- Set the function F-06-01 of the counting scale to **other than '3'**.
- Set the function F-06-03 of a counting scale to '1'.

5. Communication Specifications

5-1. RS-232C Connector (D-sub 9 pin): PRINTER

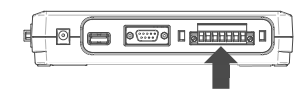

- Communication between the counting scale and a printer (or PC) is operable with an RS-232C interface.
 - Transmission system: EIA RS-232C
 - Transmission form: Asynchronous, bidirectional, half-duplex transmission
 - Data format:

| | |
|--------------|-------------------------|
| Baud rate * | 2400 bps |
| Bit length * | 7 bit |
| Parity * | EVEN |
| Start bit | 1 bit |
| Stop bit | 1 bit |
| Code used | ASCII |
| Terminator | CRLF (CR: 0Dh, LF: 0Ah) |

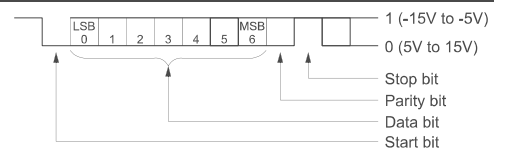

*The settings are changeable (Refer to '6. Functions')

- Pin layout

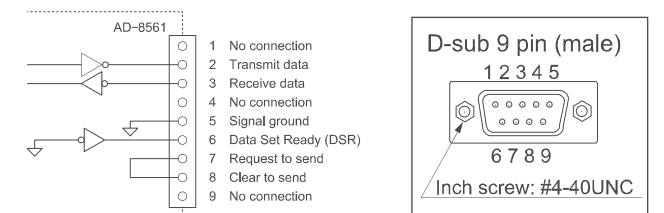

5-2. USB Connector (Type A): BARCODE READER

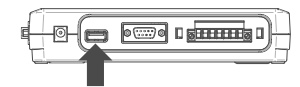

- Attach a barcode reader or keyboard to send entered text to the counting scale.
 - Transmission system : USB 2.0
 - Connector : Type A
 - Device class : HID
- Once the device is connected, the color of the LED light changes from blue to white or yellow.
 - The color does not change if the AD-8561 cannot recognize the connected device. In this case, restart the AD-8561 and reconnect the device..
 - Red LED light blinks when a device of not supported device class is connected. Note that data may be corrupted if a USB drive is mistakenly attached.

- Modes and data to transmit *Modes are selectable (Refer to '6. Functions').
 - Key mode: To be used when a counting scale searches/registers an ID or item.
 - For searching/registering ID: The last 6 digits of the input data are recognized as an ID.
 - For searching/registering item code: Up to 20 digits from the beginning of the input data are recognized as an item code and forward-matching searching can be done.
 - Command mode: To be used when sending commands to a counting scale
 - For commands, refer to the instruction manual for the counting scale.
 - Up to 64 digits in a string can be transmitted. (The data is deleted without being sent if more than 64 digits are input. Restart the AD-8561 to prevent errors in a subsequent communication data. Refer to '4-1. Connection to Power Supply')
- Caution
 - Barcode reader
 - Set your barcode reader to add a linefeed code 'Enter' to the suffix of data (suffix setting).
 - Keyboard
 - In command mode, a counting scale cannot recognize the input data until 'Enter' key is pressed. Make sure to press 'Enter' key at the end of each data entry. Characters are not shown while being entered.
 - Re-enter from the beginning if wrong characters are entered.
- Characters that can be entered
 - Numerical: 0 - 9
 - Alphabetical: A - Z (Disable caps lock to enter lower-case letters)
- Symbols: Refer to the instruction manual of the counting scale for symbols that can be entered to the device. The keyboard entry is based on the US keyboard (101 / 104). For the details, please refer to the A&D website.

5-3. External Scale (terminal block): LOAD CELL

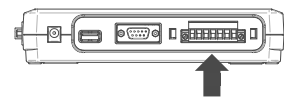

- Connect an optional weighing platform (SB series, etc.) to the terminal block to send weighing data to the counting scale.
- For how to use the external scale and the specifications of usable weighing platform, refer to the instruction manual of the counting scale.
- Pin layout

| Terminal | Connection signal |
|----------|-------------------|
| 1 | Shield |
| 2 | EXC+ |
| 3 | No connection |
| 4 | No connection |
| 5 | EXC- |
| 6 | SIG+ |
| 7 | SIG- |

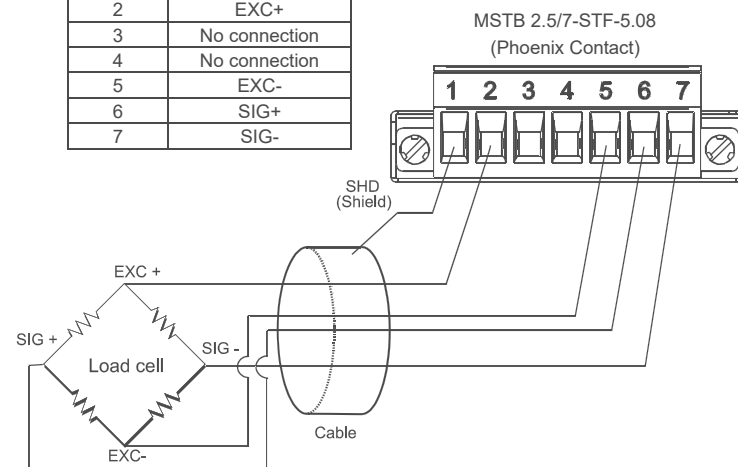

5-4. Connector for the Counting Scale (D-sub 9 pin): BALANCE / SCALE

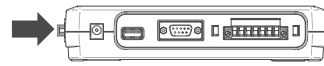

- This performs communication with the counting scale via RS-232C interface.
 - Transmission system and transmission form are same as those mentioned in '5-1. RS-232C Connector (D-sub 9 pin): PRINTER.'
 - Signal type:

| | |
|------------|-----------|
| Baud rate | 19200 bps |
| Bit length | 8 bit |
| Parity | None |
- Pin layout

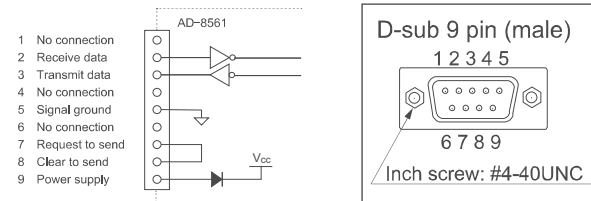

- Use the included cable (D-sub 9 pin, 1m) to connect to the counting scale.
- Supply power to the AD-8561 from the 9th pin of this connector. (Refer to '4-1. Connection to Power Supply')
- When operating the function setting for the AD-8561 with this connector, supply power with an AC adapter by connecting to a PC instead of the counting scale with a crossover cable.

6. Functions

The function setting can be operated with commands.

1. Connect a PC to the AD-8561 to send commands for the function list.

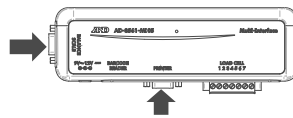

2. '<AK>' is returned when the setting is saved.

If there is no response, check the communication settings to send commands again.

| Response | Meaning | Action to take |
|----------|-------------------|--|
| <AK> | Saved | Restart the device to apply the settings. |
| EC, E1 | Undefined command | The command is not correct. |
| EC, E2 | Failed | Restart the device and redo the procedures. If the problem persists, there may be a problem with the internal circuitry. |

Note: When a string that starts with '@MI,' is received, it is recognized as a command for the AD-8561 and the data is not sent to other channels.

3. The communication settings are saved and applied after the AD-8561 is restarted.

Function list

| Applicable connectors | ◆: Factory settings | | |
|---|---------------------|---|--------|
| | Setting details | Commands | |
| [PRINTER] RS-232C connector (D-sub 9 pin) | Baud rate | 2400 bps ◆ | @MI024 |
| | | 4800 bps | @MI048 |
| | | 9600 bps | @MI096 |
| | | 14400 bps | @MI144 |
| | | 19200 bps | @MI192 |
| | | 28800 bps | @MI288 |
| Data length parity | 7 bit, EVEN ◆ | @MI7EV | |
| | 7 bit, ODD | @MI7OD | |
| | 8 bit, no parity | @MI8NO | |
| [BARCODE READER] USB connector (Type A) | HID mode | Key mode ◆ (when searching and registering ID/items with the counting scale) | @MICKM |
| | | Command mode (when sending commands to the counting scale) | @MICCM |

7. Troubleshooting

| Phenomenon | Possible cause | Action to take |
|---|---------------------------------|---|
| LED does not light blue when power is supplied. | Poor connection of power source | Turn on the power to the counting scale. If the problem persists, switch to an AC adapter for power supply. Check the output rating of the AC adapter. |
| Red LED lights | Internal circuitry error | Restart the device. |
| LED does not light white or yellow. | Connection error | Check the specifications of the USB device. |
| When a barcode reader is connected, the device does not work. | Insufficient power supply | Switch to AC adapter for power supply. |
| Communication fails. | Connection error | Check the wiring of connector. |
| | Communication settings | Reconfirm communication settings are different for each channel. |
| External scale not working | Connection error | Check the wiring. |
| | | The counting scale is not set to the AD-8561 connection mode. |

8. Specifications and Options

8-1. Specifications

| | |
|----------------------------|--|
| Model | AD-8561-MI05 |
| Power source | AC adapter (DC 9 V to 12 V / 500 mA or higher) |
| Temperature range | -10°C to 40°C (No condensation should be observed) |
| Display (LED) | Power on (blue), USB Type A connected (white/yellow), Error (red) |
| Power consumption | Approximately 0.2 VA (when USB Type A is not connected) |
| Size (W x D x H) | 195 x 60 x 40 [mm] |
| Weight | Approximately 190 [g] |
| Materials | Case: ABS, magnets: ferrite, magnet support hole: iron |
| Items included | D-sub 9 pin cable (for connecting a counting scale), instruction manual |
| Connectable counting scale | GC series counting scale (refer to the A&D website) |
| Connector form | Connector for a counting scale/RS-232C: D-sub 9 pin (male) USB host: Type A External scale: Terminal (7 pin) |

8-2. Related Software

The following software can be downloaded from the A&D website (<https://www.aandd.co.jp/>).

- (1) WinCT (data processing software for balances and scales)
Support > Software > WinCT.

8-3. Optional Devices

- (1) AC adapter
Check for the latest adapter in the products page on the A&D website.
- (2) D-sub 9 pin cable for connecting a counting scale
Same cable as the accessory
 - 1m: AX-KO2741-100
 * If a longer cable is required, a 2-m/5-m cable listed in (3) is usable. However, when a cable listed in (3) is used, power cannot be supplied from a counting scale. A separate AC adapter should be connected for power supply.
- (3) D-sub 9 pin cable for RS-232C
 - 2m: AX-KO2466-200
 - 5m: AX-KO2466-500
 * If a 1-m cable is sufficient, a cable mentioned in (2) is usable.

- (4) GC-14 (mounting hardware exclusively for GC, option for GC series counting scales)

The GC-14JA should be attached to the counting scale as follows.

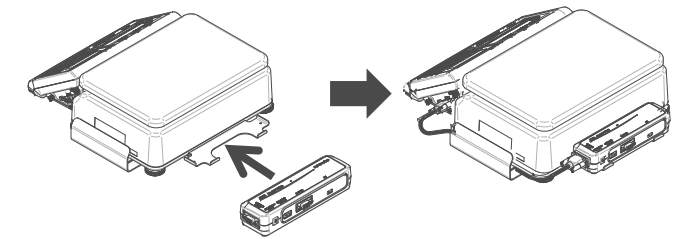

- (5) AD8561-11 (terminal block cover)
Same cover as the accessory.

