

HV-C/CP series

HW-C/CP series

INSTRUCTION MANUAL

Digital Platform Scale

HV-15KC	HV-15KCP
HV-60KC	HV-60KCP
HV-200KC	HV-200KCP
HW-10KC	HW-10KCP
HW-60KC	HW-60KCP
HW-100KC	HW-100KCP
HW-200KC	HW-200KCP

© 2017 A&D Company Ltd. All rights reserved.

No part of this publication may be reproduced, transmitted, transcribed, or translated into any language in any form by any means without the written permission of A&D Company Ltd.

The contents of this manual and the specifications of the instrument covered by this manual are subject to change for improvement without notice.

Windows, Word and Excel are registered trademarks of the Microsoft Corporation.



Contents

1. COMPLIANCE	3
1.1. Compliance with FCC rules	3
2. OUTLINE AND FEATURES	4
3. PRECAUTIONS	5
3.1. Installing the Scale	5
3.2. Operating the Scale	5
3.3. Storing the Scale	5
4. INSTALLING THE SCALE	6
4.1. Setting up the Scale	6
4.1.1. Procedure	6
5. UNPACKING	7
5.1. Accessories and Options List	8
5.2. Installing the Batteries for Type C	10
5.3. Removing the Pole	11
5.3.1. Procedure	11
5.4. Grounding the scale	12
6. DESCRIPTION OF EACH PART	13
6.1. Display and Symbols	14
6.2. Keys	16
7. BASIC OPERATION	18
7.1. Turning the Scale on/off and Weighing	18
7.1.1. When Using the AC Adapter	18
7.1.2. Type C with Batteries	19
7.2. Tare (And Net Display)	20
7.2.1. Tare Input by Weighing	20
7.2.2. Digital Input (Preset Tare)	20
7.3. Switching the mode	21
8. COUNTING MODE	22
8.1. Storing a Unit Mass	22
8.2. Counting the Number of Articles	23
9. ACCUMULATION FUNCTION	24
10. COMPARATOR	26
10.1. The formula to compare	27

10.2. Entering the comparator values	27
11. AUTO-TARE	29
11.1. Built-in Printer for HV/HW-CP Series	30
12. ID NUMBER AND GLP	32
12.1. Setting the ID number	32
12.2. Setting the clock.....	33
12.3. GMP report	34
13. CALIBRATION (ADJUSTING THE SCALE)	38
13.1. Gravity Acceleration Table	39
13.2. Complete Calibration Procedure	40
13.2.1. Gravity Acceleration Correction	40
13.2.2. Preparation	40
13.2.3. Calibration of the Zero Point	41
13.2.4. Span Calibration	41
14. FUNCTION TABLE	42
14.1. Parameter Setting Procedure.....	42
14.2. Parameter List.....	43
15. OPTIONS.....	48
15.1. Installing an option	48
15.2. HVW-02CB USB Interface.....	48
15.3. HVW-03C RS-232C Interface.....	49
15.4. HVW-04C Comparator Relay Output / Buzzer / Contact Input	50
15.5. Communication format.....	51
15.5.1. Command mode	52
15.6. Using UFC (Universal Flex Coms) Function	58
16. SPECIFICATIONS	61
17. MAINTENANCE.....	65
17.1. Check Points Before Calling Maintenance Service	65
17.1.1. Repair	65



1. Compliance



1.1. Compliance with FCC rules

- Please note that this equipment generates, uses and can radiate radio frequency energy. This equipment has been tested and has been found to comply with the limits of a Class A computing device pursuant to Subpart J of Part 15 of FCC rules. These rules are designed to provide reasonable protection against interference when this equipment is operated in a commercial environment. If this unit is operated in a residential area it might cause some interference and under these circumstances the user would be required to take, at his own expense, whatever measures are necessary to eliminate the interference.

(FCC = Federal Communications Commission in the U.S.A.)



2. Outline and Features

- The HV-C/HW-C series are platform scales with 1/3000 resolution, and have the triple weighing range function to select the weighing range. The scale automatically switches to small scale interval when a light sample is weighed or large scale interval when a heavy sample is weighed, depending on the sample weight (multi-interval).
- The HV-C/HW-C series come with two types of resolution;
1/10000: Standard models
- Type CP scales are equipped with a built-in printer.
- Type C scales use batteries or an AC adapter as a power source.
- The scales use a back lit liquid crystal display to enable viewing in dim light.
- Using the optional RS-232C serial interface or USB interface, data can be output to a printer. Also, the weighing value can be output, the scale can be controlled or the setting value can be set by a command from a personal computer.
- The counting mode converts the total mass value (total weight) of articles to be counted, to a count, when each article has the same mass value.
- The comparator function compares the displayed weight value with the upper limit value (HI) and the lower limit value (LO) and displays the result. The result can be output by a buzzer if option HVW-04CJA is installed.
- The scale has an accumulation function with a maximum of 6 digits, which has a maximum accumulations of 999 times. (The number of times weighed and the total mass of that can be stored in the scale.),
- The optional RS-232C serial interface, USB interface or comparator relay output can be installed to the scale with up to three units.
- The following parameters are stored in the scale even if the power is removed.

Display mode (unit)
Unit mass of counting mode
Total count and total mass of accumulation function
Upper limit value and lower limit value of upper / lower comparator function,
Calibration data
Parameters of the function table

- Multi-interval: This is what the minimum display is automatically switched to depending on the sample weight

Example) With the HV-60KC, weighing capacity is 60kg and minimum display is 0.005kg, 0.01kg or 0.02kg.

Multi-interval: When exceeding the range for small, medium or large, the minimum display is automatically switched

Point: When a light sample is weighed, the minimum display is small.
When a heavy sample is weighed, the minimum display is large.

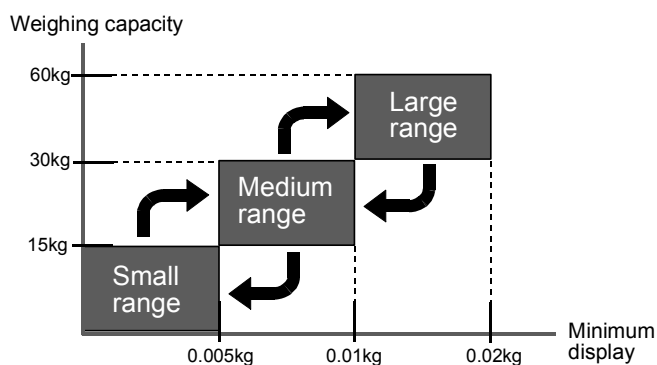



3. Precautions



3.1. Installing the Scale

Consider the following conditions to get the most from your scale.

- Install the scale where the temperature and relative humidity is stable, there is no draft and a stable power source is available.
- Install the scale on a solid and level surface.
- Do not install the scale in direct sunlight.
- Do not install the scale near heaters or air conditioners.
- ⚠ □ Do not install the scale where there is flammable or corrosive gas present.
- Do not install the scale near equipment which produces magnetic fields.
- Do not install the scale where there is apt to be static electricity, in a place where the relative humidity is lower than 45% RH. Plastic and isolators are apt to be charged with static electricity.
- The display unit is not water resistant. Use the display unit cover to avoid damage.
- Do not use an unstable power source.
- Remove the protective film from the weighing pan before use.



3.2. Operating the Scale

- Periodically ensure that the weight value is correct.
- Calibrate the scale before using and after moving it to another location.
- Do not place anything on the pan which exceeds the weighing capacity.
- Do not drop anything upon the pan.
- Do not use a sharp instrument such as a pencil to press the keys. Press the keys gently using your finger.
- Pressing the **ZERO** key before each weighing is recommended to prevent possible error.
- Replace the used batteries with four new ones when the “L_b” mark is displayed. Battery is of type D, Mono, R20P, R20PU or LR20.



3.3. Storing the Scale

- Do not disassemble the scale.
- Do not use solvents to clean the scale. Wipe it with a dry lint free cloth or a lint free cloth which is moistened with warm water and a mild detergent.
- The base unit can be cleaned with gentle running tap water. Do not scratch the base unit with a brush. Allow the unit to dry before using.
- Protect the display unit from dust and water.
- Remove the batteries from the display unit when the scale is not to be used for a long time. If you leave the batteries installed, they may leak and damage the scale.



4. Installing the Scale



4.1. Setting up the Scale

4.1.1. Procedure

This procedure includes all of the steps for installing the scale. Therefore, there may be some unnecessary steps for some models.

Step 1 Take the base unit and pole out, taking care not to pull on the load cell cable.

Step 2 Place the pan on the base unit. Remove the protective film from the pan before use.

Step 3 Attach the pole to the bracket of the base unit, while using care not to damage the load cell cable. Insert the remainder of the load cell cable into the pole.

Affix the pole to the bracket using two Allen screws.

* With the HW-10KC, HW-10KCP, HV-15KC and HV-15KCP, this procedure is not required because the pole and bracket is a combined unit.

Step 4 Select a place for installing the scale. Refer to "3.1. Installing the Scale" .

Step 5 Adjust the level of the base unit using the bubble spirit level and the leveling feet.

Step 6 Press the caps at the pole top from both sides and adjust the angle of the display unit.

Step 7 Check the weighing accuracy. If the scale needs calibration, refer to "14. Calibration".

- The display unit can be adjusted in four steps in the up-and-down direction.

Setting the display sideways is also possible. (Make sure that the pole is secured at the lower part of the pole using the allen screws. Do not turn the display unit at a joint for the pole.)

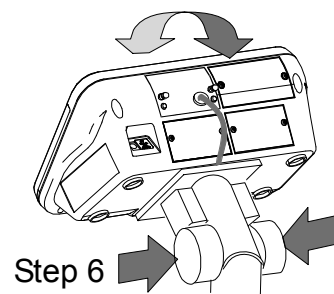
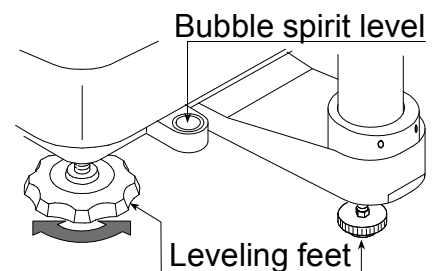
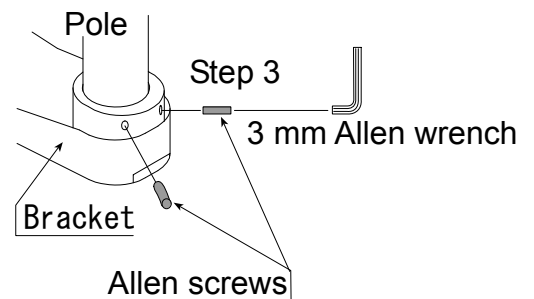
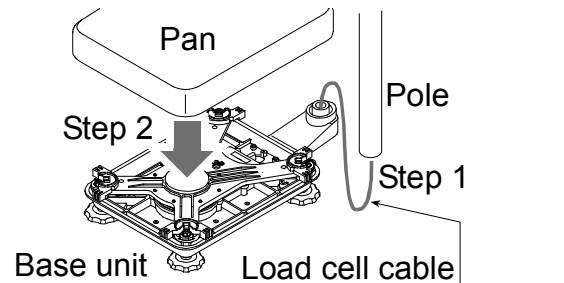



5. Unpacking

Models
HV-15KC
HV-15KCP
HW-10KC
HW-10KCP

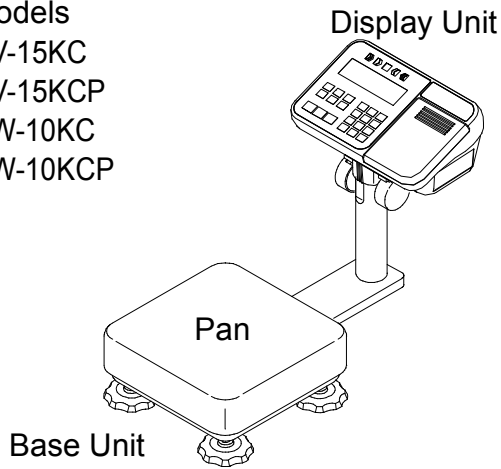

Models
HV-60KC HV-60KCP
HW-60KC HW-60KCP

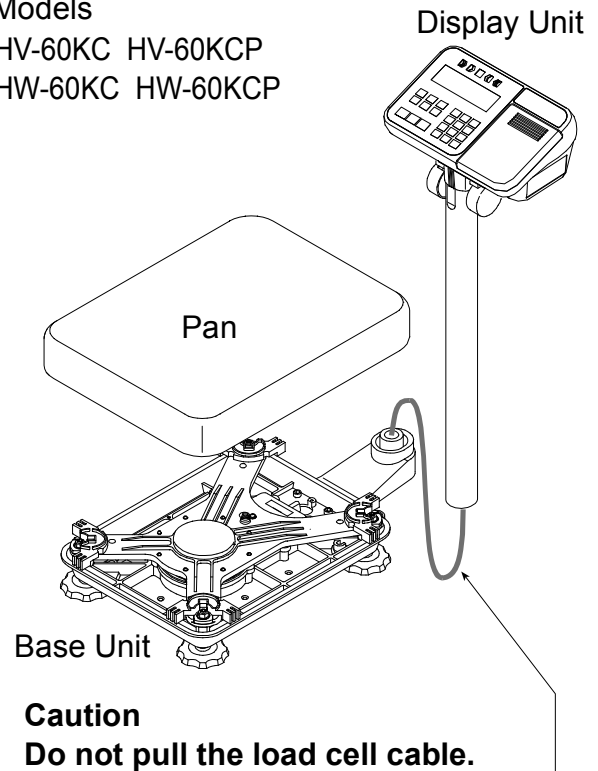

Caution
Do not pull the load cell cable.

Models
HV-200KC HV-200KCP
HW-100KC HW-100KCP
HW-200KC HW-200KCP

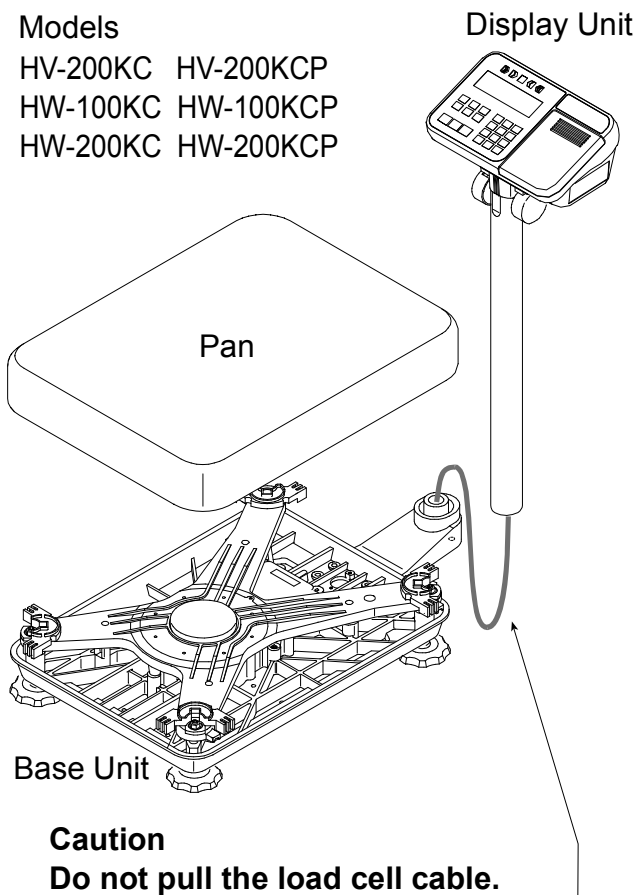

Caution
Do not pull the load cell cable.

Accessories

Refer to "Accessories List" on page 8.
Accessories supplied depend on the scale model.

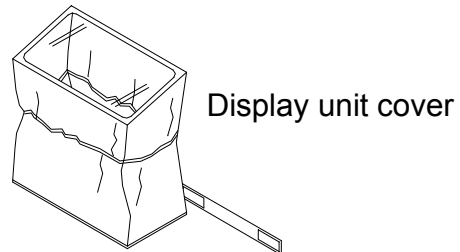
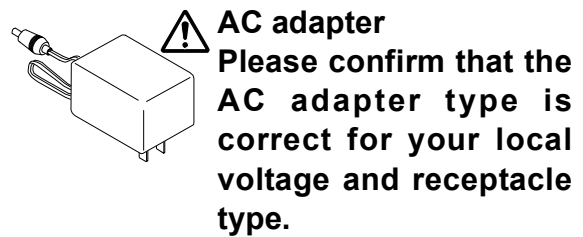

Type C/CP

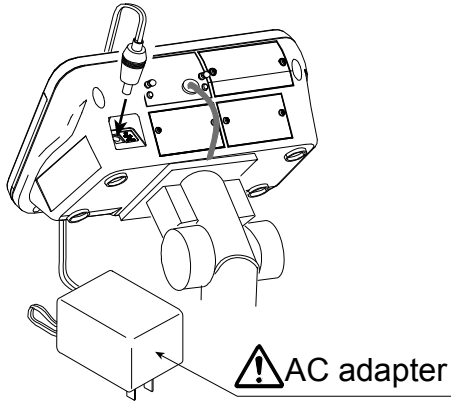

Type C

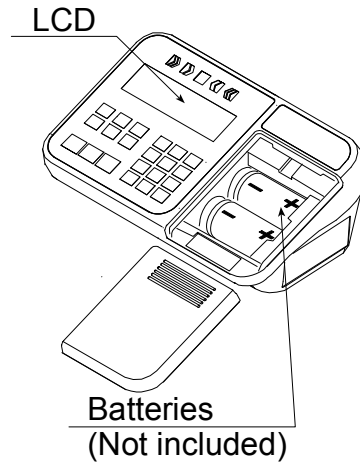

Please confirm that the main power type or AC adapter type is correct for your local voltage and receptacle type.



5.1. Accessories and Options List

Accessories List

Type	Models	Accessories (Quantity)
C	HV-15KC HW-10KC	- Display unit cover (1) - AC Adapter (1) - Instruction manual (1)
	HV-60KC HV-200KC HW-60KC HW-100KC HW-200KC	- Display unit cover (1) - Allen wrench (1) - AC Adapter (1) - Instruction manual (1)
CP	HV-15KCP HW-10KCP	- Display unit cover (1) - AC Adapter (1) - Instruction manual (1) - Special roll paper (1)
	HV-60KCP HV-200KCP HW-60KCP HW-100KCP HW-200KCP	- Display unit cover (1) - Allen wrench (1) - AC Adapter (1) - Instruction manual (1) - Special roll paper (1)

Options List

Order code	Option name
HVW-02CB	USB interface
HVW-03C	RS-232C interface
HVW-04C	Comparator relay output / Buzzer / Contact input
HVW-08C	Extension load cell cable (For weighing capacity of 10 kg to 200 kg) * When the scale is installed using this cable, the scale requires recalibration.
HVW-11C	Wall mounting kit
HVW-13	Roller conveyor for HV-200KC, HW-100KC and HW-200KC
HVW-14	Roller conveyor for HV-60KC and HW-60KC
AX-KO2466-200	RS-232C cable, D-sub 25 pin, 2 m RS-232C cables are also available in lengths of 5 and 10 m.

Note OP-16 is factory-installed.
For handling HVW-11C, 13 and 14, refer to the relevant option manual.

Consumables

AX-PP147-S	Special roll paper for the built-in printer (set of 5 rolls)	A
------------	--	---



5.2. Installing the Batteries for Type C

- Step 1 Turn off the display.
Remove the AC adapter.

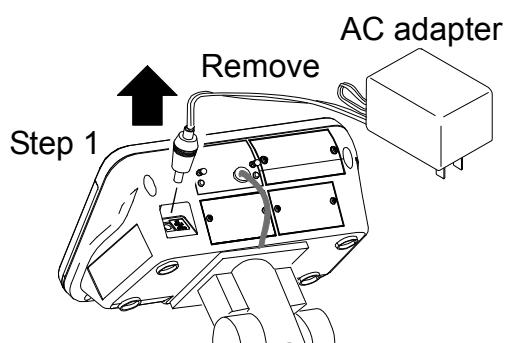

- Step 2 Press and slide the ext. cover to open it.
Press the hook of the int. cover to the left side and lift it.

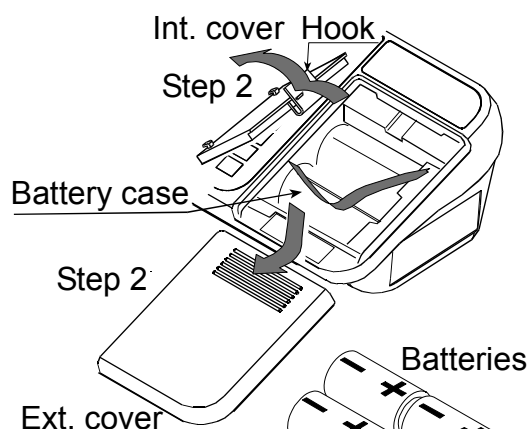

- Step 3 Insert four new batteries with proper polarity (+,-). Battery is of type D, Mono, R20P , R20PU or LR20.

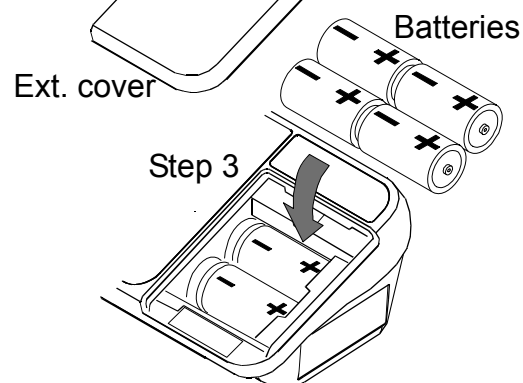

- Step 4 Close the covers in reverse order of step 2.

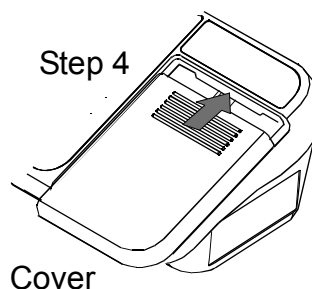

Caution

- ❑ **Replace used batteries with four new ones, when “Lb” is displayed.**
- ❑ **Do not mix used and new batteries. It may cause damage to the batteries or the scale, if used.**
Check the battery direction. If the batteries are installed in the wrong direction, it may cause battery leakage. If the direction of a single battery is wrong, the scale may work only temporarily.
- ❑ **The battery life depends on the ambient temperature.**
- ❑ **Remove the batteries from the display unit, when the scale is not to be used for a long time. They may leak and cause damage.**
- ❑ **Damage which is due to battery leakage is not covered under warranty.**



5.3. Removing the Pole

Caution

- ⚠️ □ Remove the AC adapter and batteries before removing the pole.
- When removing the load cell cable, do not pull on the load cell cable connector forcibly and do not pull on the wires of the cable.
- Do not bend the cable forcibly. Use care so that the load cell cable does not touch the pan inside the base unit.
- Avoid dust, static electricity and high humidity (or condensation) because the inside of the display unit is sensitive.

5.3.1. Procedure

- Step 1 Turn the scale off.
Remove the AC adapter and batteries.
- Step 2 Open the rear cover of the display unit.
Disconnect the load cell cable connector gently (perpendicularly and do not pull toward you).
- Step 3 Remove the four 4 mm screws, which are used to attach the display unit to the pole.
- Step 4 Remove the ferrite core and the cable clamp from the load cell cable.
- Step 5 (HV-60KC, HV-60KCP, HW-60KC, HW-60KCP, HV-200KC, HV-200KCP, HW-100KC, HW-100KCP, HW-200KC and HW-200KCP only)
Remove the 3 mm screws from the bottom cover of the bracket.
- Step 6 Carefully remove the load cell cable from the pole and the bracket. Particularly with HW-10KC, HW-10KCP, HV-15KC and HV-15KCP, take care not to pull on the connector forcibly.
- Step 7 Arrange the cable so that it does not touch the pan in the base unit. The untied cable is approximately 2 m. The optional extension load cell cable (HVW-08C) is 5 m long.
- Step 8 Remove the bracket from the base unit. An Allen wrench is required.

HV-15KC/HV-15KCP	HV-200KC/HV-200KCP
HV-60KC/HV-60KCP	HW-100KC/HW-100KCP
HW-10KC/HW-10KCP	HW-200KC/HW-200KCP
HW-60KC/HW-60KC	
5 mm Allen wrench	6 mm Allen wrench

- Step 9 Wind the cable through the ferrite core two times. Affix the cable to the rear cover using the cable clamp.
- Step 10 Connect the cable to the connector. Close the rear cover.
- Step 11 Check the weighing accuracy.

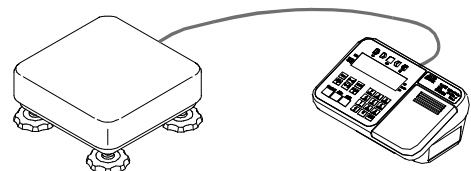
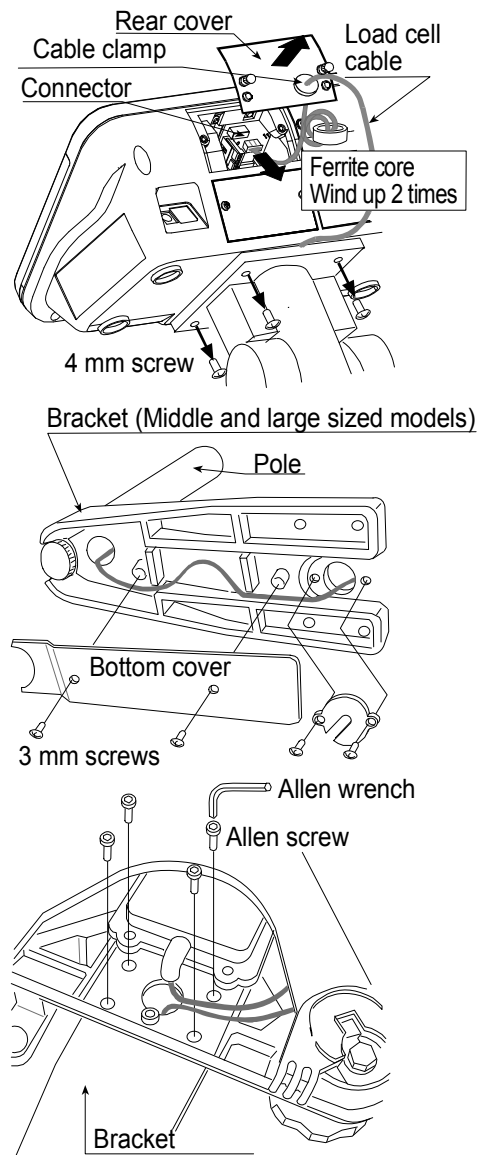



5.4. Grounding the scale

When using where there may be static electricity, ground the scale.

The grounding procedure depends on the scale model. Refer to the table below.

These procedures are only for grounding part of the scale.

Models	Refer to
HV-15KC/HV-15KCP/ HW-10KC/ HW-10KCP	Procedure A
HV-60KC/HV-60KCP/HV-200KC/HV-200KCP HW-60KC/ HW-60KCP/ HW-100KC/ HW-100KCP/ HW-200KC/ HW-200KCP	Procedure B

Procedure A

(HV-15KC/HV-15KCP/ HW-10KC/ HW-10KCP)

Secure the grounding cable using a M4 screw in the screw hole between the two hexagon bolts on the base unit bottom side. (Part of “⇨”)

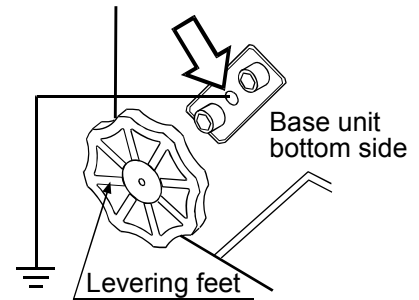

Procedure B

(HV-60KC/HV-60KCP/HV-200KC/HV-200KCP
 HW-60KC/ HW-60KCP/ HW-100KC/ HW-100KCP
 HW-200KC/ HW-200KCP)

Secure the grounding cable using the screw that secures the under cover. (Part of “⇨”)

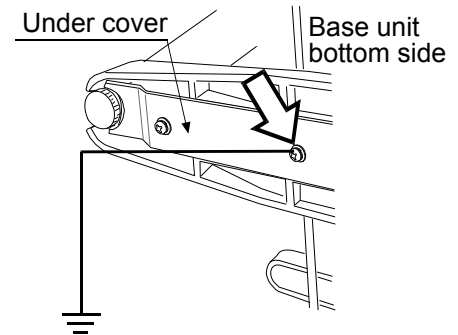



6. Description of Each Part

Models
 HV-15KC
 HV-15KCP
 HW-10KC
 HW-10KCP

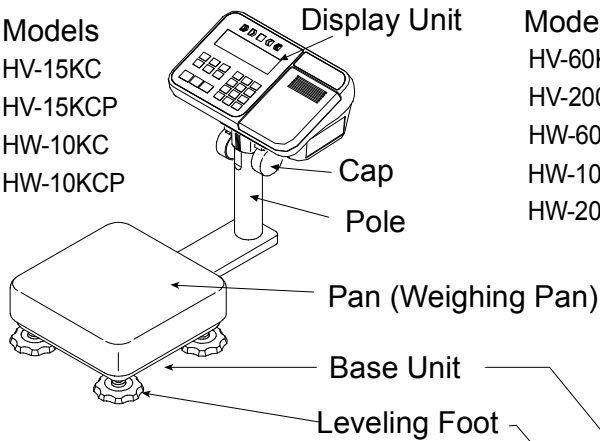

Models
 HV-60KC HV-60KCP
 HV-200KC HV-200KCP
 HW-60KC HW-60KCP
 HW-100KC HW-100KCP
 HW-200KC HW-200KCP

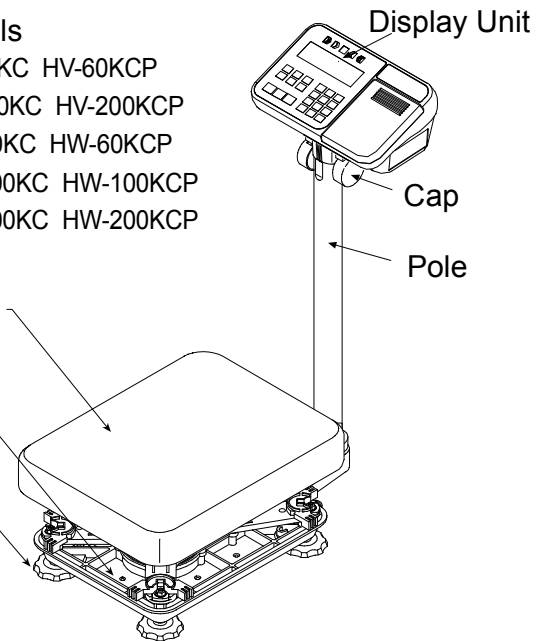

Type C

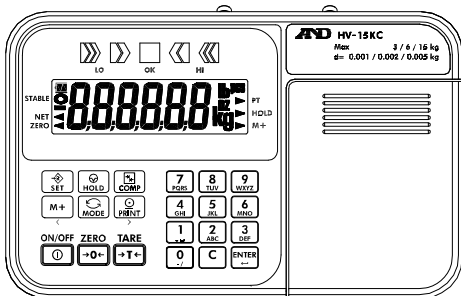

Type CP

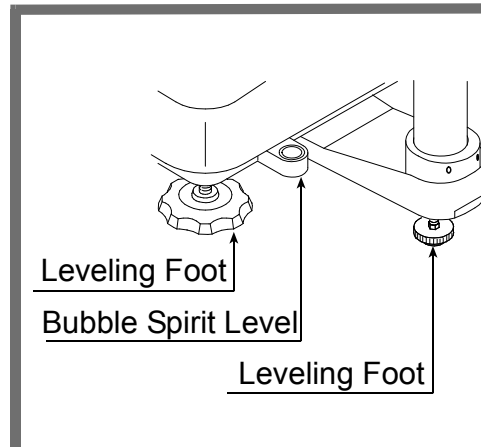
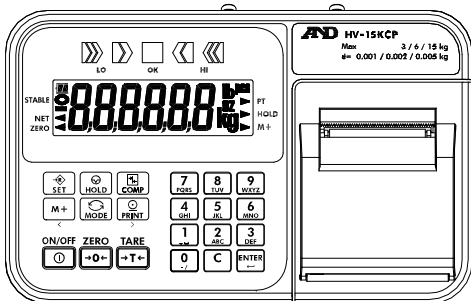

CAL switch
 Calibrating the scale
 to weigh correctly.

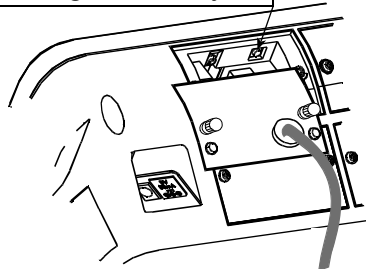





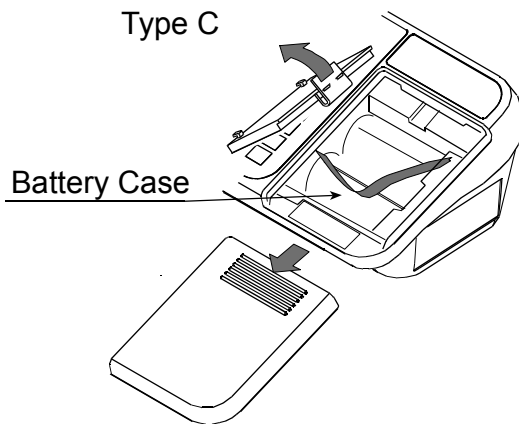

Caution
 The certified mass is required.



Type C





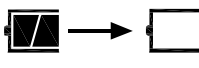
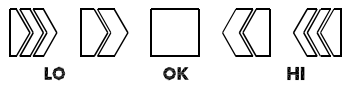
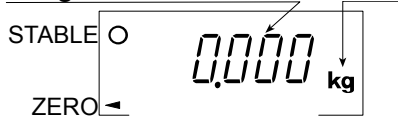

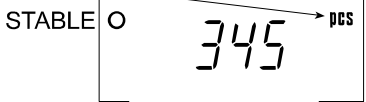
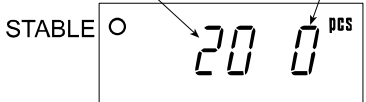
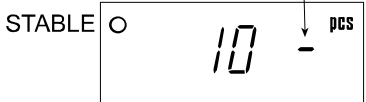
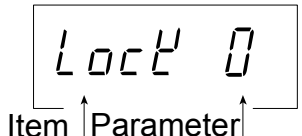
6.1. Display and Symbols

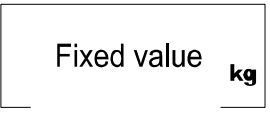
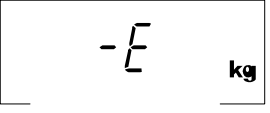
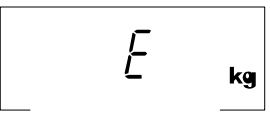
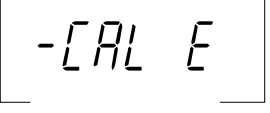
Display and Symbols	Description
	<p>Stability mark When the current weight value is stable, this mark is displayed. It means a proper condition that this value is readable.</p>
	<p>Zero point mark When the ZERO key is pressed with nothing on the pan, this mark is displayed. The zero point is the fundamental starting point to weigh anything.</p>
	<p>Net mark When the TARE key is pressed, this mark is displayed. Used to indicate that the mass of the container placed on the pan has been subtracted from the gross value.</p>
	<p>Preset tare mark While a tare with digital input is displayed, this mark blinks.</p>
	<p>Hold mark While the display is held, this mark is displayed.</p>
	<p>Accumulation mark While the accumulation function is used, this mark is displayed.</p>
	<p>Low battery mark for type C When the battery is depleted (becoming low voltage), this mark is displayed. Replace with four new batteries.</p>
	<p>Comparator indicator When using the comparator function, the result is indicated after the weight value is compared with the upper and lower limits.</p>
<p>Weighed mass value unit</p> 	<p>Zero point (Example) When the ZERO key is pressed with nothing on the pan, the zero point mark and the stability mark are displayed.</p>



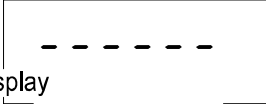





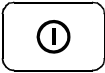
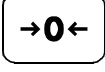
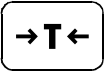
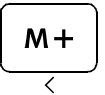







Display and Symbols	Description
<p>Unit of counting mode</p> 	<p>Counting mode (Example) This mode uses the stored unit mass and counts the number of articles on the pan. The unit is PCS.</p>
<p>20 pieces Zero value</p> 	<p>Storing the unit mass for the counting mode (Example) The unit mass is stored, using 20 pieces of samples. The zero value means that no articles are on the pan.</p>
<p>No zero value</p> 	<p>Storing the unit mass for the counting mode (Example) The unit mass is stored, using 10 pieces of samples. Sign "-" means that something is placed on the pan.</p>
	<p>Function settings (Example)</p> <ul style="list-style-type: none"> - Press the MODE key to select the item, and then press the ENTER key to finalize the selection. - Enter a parameter using the numerical keypad. - Press the ENTER key to store the new parameters.
<p>Example</p> 	<p>While preset tare setting (Example)</p> <ul style="list-style-type: none"> - Enter a setting value using the numerical keypad. - Press the ENTER key to store the new tare.
	<p>Hold display (Example) The hold display is set using <i>HoLd</i> of the function table. When the weight value is "nearly-zero" (within the zero band) or changes more than 25% +30 digits, the hold is canceled.</p>
	<p>Weighing error Check the base unit and the weighing pan.</p>
	<p>Overload display Remove anything that is on the pan.</p>
	<p>Calibration error The calibration mass is too light. Check the base unit and the weighing pan.</p>

The "digit" is a unit of display, and is equivalent to the minimum measurable mass.
The "nearly-zero" or zero band is within ± 5 digits from zero point in the unit of kg.

Display and Symbols	Description
	Calibration error The calibration mass is too heavy. Check the base unit and the weighing pan.
Fixed display 	Does not display zero when the scale is turned on. Remove anything that is on the weighing pan. Perform zero point calibration. Or The weight value is unstable due to drift or vibration when the scale is turned on. A breeze or vibration may be affecting the measurement. Check around the weighing pan.
Blinking  M+	Accumulated data count
Blinking  M+ and lighting up kg	Total mass value of the accumulated data
e.g. CAP. MAX. 3/6/15kg d=1/2/5g	The weighing range and measurable minimum mass. Example: Displays the weight value by 5 g up to 15 kg. Displays the weight value by 2 g up to 6 kg. Displays the weight value by 1 g up to 3 kg.

6.2. Keys

Display and Symbols	Description
ON/OFF 	ON/OFF key The scale is in standby status when power is connected using the AC adapter.
ZERO 	ZERO key When the ZERO key is pressed with nothing on the pan, the scale displays the mass value of zero and the zero point mark. If the scale is in tare in this time, the tare value is cleared. When accumulation is displayed, the accumulation is cleared.
TARE 	TARE key Canceling the mass of a container which is placed on the pan and does not weigh its mass. Note The tare reduces the weighing range.
M+ 	Adds to the accumulated data.

Display and Symbols	Description
	<p>SET key When setting the upper/lower limit, switch between + and -.</p>
<p>Press and hold  and press </p>	<p>Enters preset tare setting mode</p>
<p>Press and hold  and press </p>	<p>Performs paper feed at the built-in printer</p>
<p>Press and hold  and press </p>	<p>Displays the accumulated results</p>
<p>Press and hold  and press </p>	<p>Sets upper/lower limit values for comparator</p>
<p>Press and hold  and press </p>	<p>Proceeds to unit mass storing when using counting mode</p>
	<p>MODE key</p> <ul style="list-style-type: none"> - Switches the mode (unit) to be displayed - The mode (unit) is maintained in non-volatile memory, so the scale displays using the most recently used mode (unit) when turning on the power next time - Used as key to select the items at each setting.
	<p>HOLD key Holds the display. Refer to function settings for details.</p>
	<p>PRINT key Prints out the value displayed or outputs it as data. However, those operations differ depending on function settings.</p>
<p>Display off</p> <p>↓</p> <p>Press and hold  and press </p>	<p>Enters function settings</p>

7. Basic Operation

7.1. Turning the Scale on/off and Weighing

7.1.1. When Using the AC Adapter

- Step 1 Ground the scale.
- Step 2 Confirm that nothing is placed on the pan.
- Step 3 Confirm that local voltage and receptacle type are correct.
- Step 4 The scale turns on/off using the **ON/OFF** key alternately.
- Step 5 Check the accuracy of weighing. Allow 30-minute warm up before calibration.
- Step 6 With nothing on the pan, press the **ZERO** key to display zero.
- Step 7 Place an article to be weighed on the pan gently.
- Step 8 Wait for the stability mark to be displayed. Read the weight value.
- Step 9 Remove the article from the pan.
- Step 10 Turn the scale off using the **ON/OFF** key.

Memo

- With the AC adapter connected, the power is off at the scale, but not from the AC adapter, after the scale is turned off using the **ON/OFF** key. To shut down the power completely, disconnect the AC adapter.

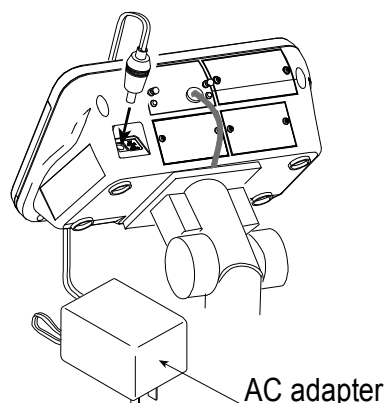

7.1.2. Type C with Batteries

Step 1 Install four new batteries. Refer to "5.2. Installing the Batteries for Type C".

Step 2 Confirm that nothing is placed on the pan.

Step 3 The scale turns on/off using the **ON/OFF** key alternately.

Step 4 Check the accuracy of weighing. Allow 30-minute warm up before calibration.

Step 5 With nothing on the pan, press the **ZERO** key to display zero.

Step 6 Place an article to be weighed on the pan gently.

Step 7 Wait for the stability mark to be displayed. Read the weight value.

Step 8 Remove the article from the pan.

Step 9 Turn the scale off using the **ON/OFF** key.

Caution

- **When \square is displayed, this means the batteries will run out soon.**
- **Replace used batteries with four new ones when “Lb” is displayed.**
- **Battery life depends on the ambient temperature.**
- **Remove the batteries from the display unit when the scale is not to be used for a long time. The batteries may leak and cause damage.**



7.2. Tare (And Net Display)

The "tare" is used to cancel the mass of a container, which is placed on the pan to contain the article to be weighed.

Caution

- **The tare reduces the weighing range.**
- **The current tare value is reset by pressing the **ZERO** key or turning the scale off. (Reset value is zero.)**
- **The storable preset tare value must be within the minimum weighing range.**

7.2.1. Tare Input by Weighing

Step 1 Place the container on the pan.

Step 2 Wait for the stability mark to be displayed. Press the **TARE** key. The display becomes zero and the net mark is displayed.

Step 3 Place an article to be weighed into the container. Wait for the stability mark to be displayed and read its net display.

Step 4 Remove the article and the container from the pan.

7.2.2. Digital Input (Preset Tare)

Step 1 Press and hold the **SET** key and press the **TARE** key.

Then the blank or stored tare value is displayed. The blank display means that the tare value is zero (reset value). And ►PT blinks.

Step 2 Enter the preset tare value using the numerical keypad.

Step 3 Press the **ENTER** key to store the new preset tare value.

Then the scale displays the net value (the gross weight value minus the tare value).

Step 4 Place an article to be weighed into the container. Wait for the stability mark to be displayed and read its net display.

Step 5 Remove the article and the container from the pan.

7.3. Switching the mode

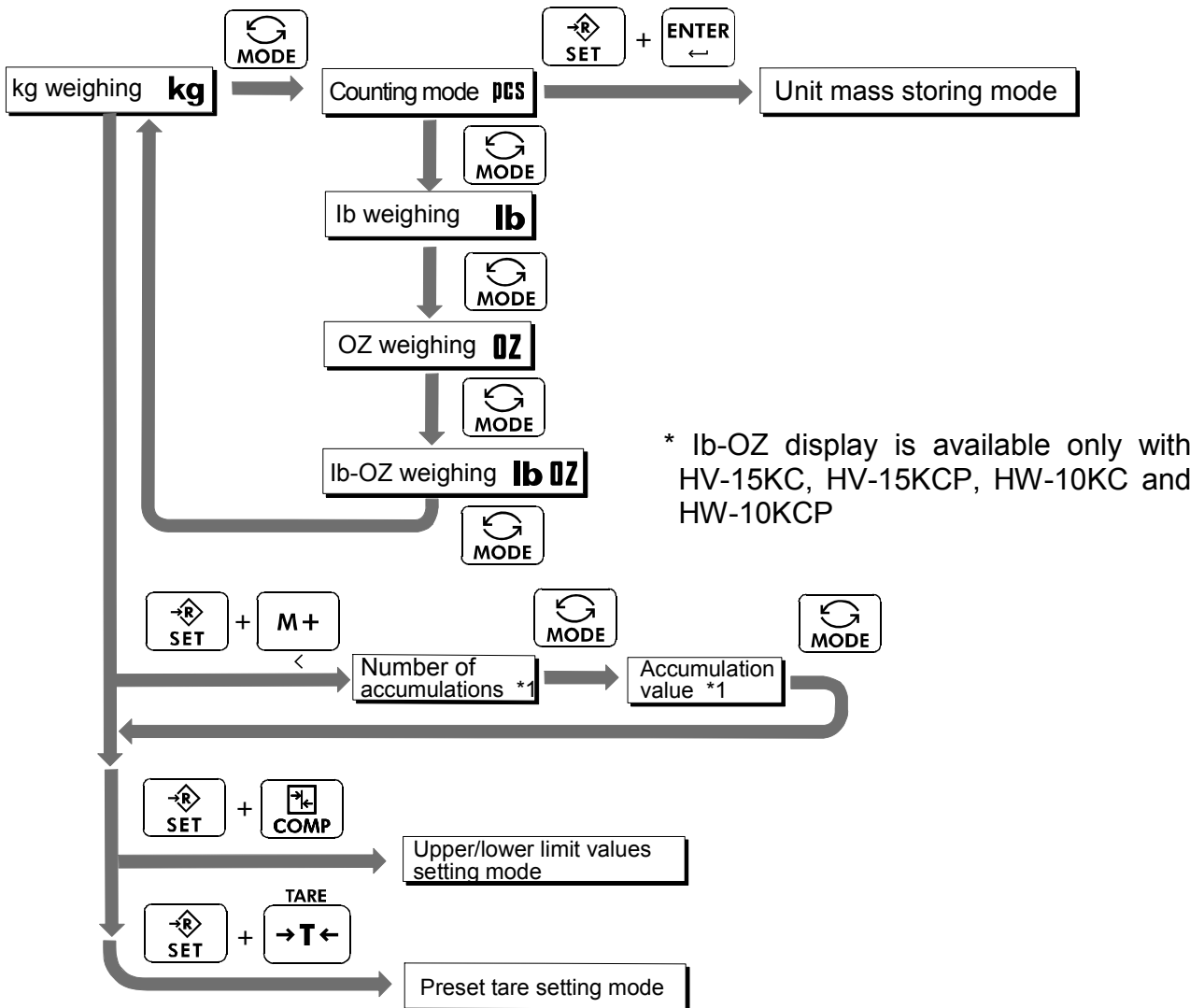

* The scale displays the number of accumulations and an accumulation value only when accumulation data exists.



8. Counting Mode

- The counting mode is the function to convert the total mass value (total weight) of articles to a count, when each article has the same mass value.
- To use this function, store a unit mass in advance.
- Even if the AC adapter or the batteries is removed, the unit mass is maintained in non-volatile memory.



8.1. Storing a Unit Mass

Step 1 Press the **MODE** key to display the unit **PCS**.

Step 2 Press the **SET** and **ENTER** key to enter the mode that stores a unit mass.

Step 3 Press the **SET** key to select the number of samples.
The greater the quantity of samples, the greater the accuracy of the count.

5 pieces, 10 pieces, 20 pieces, 50 pieces,
100 pieces

Step 4 Place the container on the pan.
Press the **TARE** key.

Step 5 Place the number of samples selected at step 3.
Wait for the stability mark to be displayed. Press the **ENTER** key to store. The count is displayed.

Caution

- When the sample total mass value is too small and it is not possible to calculate a unit mass, the scale displays **Lo ut** and returns to step 3. Increase the number of samples. More than 10 digits of the total sample mass, in the unit of kg, are required.
- When the unit mass is too light to store, the scale displays **Lo ut**. In this case, the unit mass will not be stored even if the number of samples is increased.
- Pressing the **MODE** key, after **Lo ut** is displayed, displays the next unit.

Step 6 Remove the samples and the container from the pan.

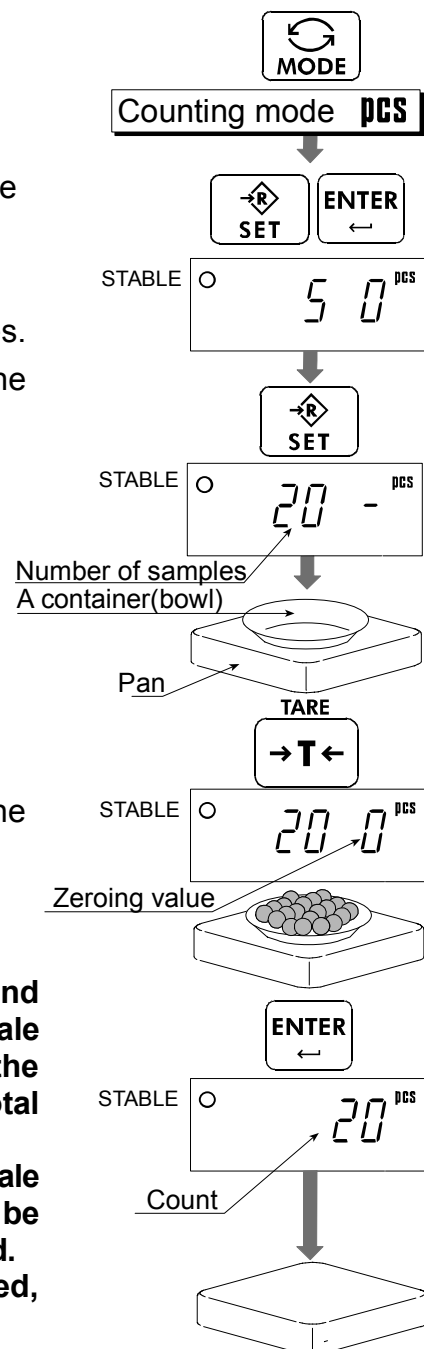

Note
The pan shape depends on the scale model.

8.2. Counting the Number of Articles

Step 1 Press the **MODE** key to display the unit **pcs**.

Step 2 Store the unit mass of the article.
Refer to "8.1. Storing a Unit Mass"

Step 3 Place the container on the pan.
Press the **TARE** key.

Step 4 Place articles in the container. Wait for the stability mark to be displayed and read the count.

Step 5 Remove the articles and the container from the pan.

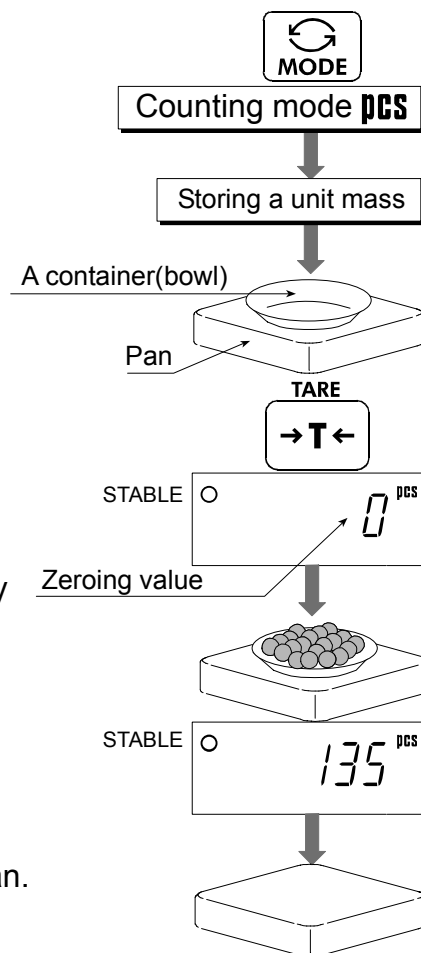

Note
The pan shape depends on the scale model.



9. Accumulation Function

- This function counts the number of times articles are weighed, calculates the total mass value and can display the number (accumulation count) and accumulated mass value.
- The accumulation function is displayed with up to 6 digits. The balance can not display 7 or more digits, therefore the leading digits are not displayed.
Example: With 60K type, when importing the data of 17 accumulations of up to 60kg (60.000 X 17=1020.000), the balance displays this as "020000".
- To use this function, set the parameters of the "Accumulation function (\overline{Sun})" in the function table in advance.
- To use the built-in printer, set the parameters of the " Built-in printer output mode (\overline{PrEPg})" in the function table in advance.
- The accumulation count and accumulated mass value are stored in the scale even if the power is removed.

Operation and Keys

- The display of the accumulation count has a blinking $\overline{M+}$ without a unit.
- The display of the accumulated mass value has a unit and a blinking $\overline{M+}$.
- Press the \overline{SET} and $\overline{M+}$ key to display the accumulation count and accumulated mass value.
- Press the \overline{ZERO} key in the accumulation function (with a blinking $\overline{M+}$) to reset the current function (The count and accumulated mass value become zero.)
- When the \overline{PRINT} key is pressed, the accumulation results (date, data number and weighing value) are printed by the built-in printer (HV/HW-CP models). Date is set at function table \overline{SetDP} .

Caution

The accumulation function is available only when weighing is performed in the same unit.

Parameter List and Word Definition

- The "nearly-zero" is within ± 5 digits from the zero point in the unit of kg.
- The "digit" is a unit of display, and is equivalent to the minimum measurable mass.
- The "zero point" is the fundamental starting point to weigh anything.

Function table	Description
$\overline{Sun} \ 0$	Accumulation function not used.
$\overline{Sun} \ 1$	The scale accumulates the data, if the $\overline{M+}$ key is pressed, when the display is a positive stable value and not nearly-zero. The next accumulation can be performed after the display becomes nearly-zero or a negative value.
$\overline{Sun} \ 2$	The scale accumulates the data, if the $\overline{M+}$ key is pressed, when the display is a stable value and not nearly-zero. The next accumulation can be performed after the display becomes nearly-zero.

Function table	Description
Σ ₀ 3	When the display is a positive stable value and not nearly-zero, the scale accumulates the data automatically. The next accumulation can be performed after the display becomes nearly-zero or a negative value.
Σ ₀ 4	<p>When the display is a stable value and not nearly-zero, the scale accumulates the data automatically. The next accumulation can be performed after the display becomes nearly-zero.</p> <p>Use Recording the number and mass of articles removed from the pan. (Place the articles on the pan. Press the TARE key at each removal.)</p>



10. Comparator

Five-level, three-level and seven-level (portion weighing mode) comparators are available.

Each comparator mode compares the weight value against the preset limit values and outputs the results using LEDs (yellow / green / red).

When the optional comparator relay output (HVW-04CJA) is installed, the results are output as a relay signal.

- Five-level comparator mode:

Uses four comparator values to compare the weight value and outputs results in five levels of LOLO, LO, OK, HI and HIHI.

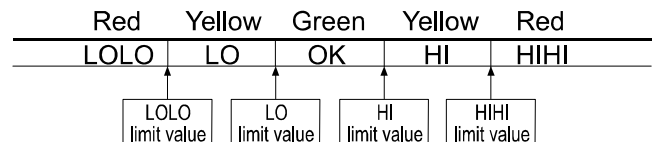

- Three-level comparator mode:

Uses two comparator values (upper and lower limit values) to compare the weight value and outputs results in three levels of LO, OK and HI.

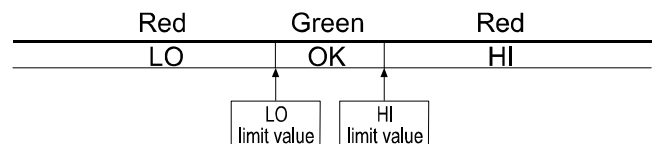

- Seven-level comparator mode (portion weighing mode):

Uses six comparator values to compare the weight value and outputs results in seven levels of over in the negative value, level 1 (LOLO), level 2 (LO), Level 3 (OK), level 4 (HI), level 5 (HIHI) and over in the positive value.

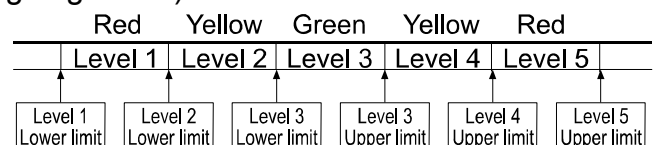

To use the comparator modes, the function settings “[P-L]” and “[P]” must be specified and the comparator values must be set.

Using the function setting “[P-L]”, select a comparator mode.

0: five-level comparator mode

1: three-level comparator mode

2: Seven-level comparator mode (portion weighing mode)

Using the function setting “[P]”, select comparison conditions.

0: No comparison (comparator mode disabled).

1: To compare all data.

2: To compare all stable data.

3: To compare all data which are more than or equal to +5d, or less than or equal to -5d.

4: To compare stable data which are more than or equal to +5d, or less than or equal to -5d.

5: To compare all data which are more than or equal to +5d.

6: To compare stable data which are more than or equal to +5d.

d = minimum display in kg (Refer to “16. SPECIFICATIONS”.)

Also in the counting mode, “d” is equal to the minimum display of kg mode.



10.1. The formula to compare

Comparison is performed using the formula listed below and the results are output.

Five-level comparator mode

Results	Comparison formula	LED display
LOLO	Displayed value < LOLO limit value (Or over in the negative value)	■□□□□ (Red LED on)
LO	Displayed value < LO limit value	□■□□□ (Yellow LED on)
OK	LO limit value ≤ Displayed value ≤ HI limit value	□□■□□ (Green LED on))
HI	HI limit value < Displayed value	□□□■□ (Yellow LED on)
HIHI	HIHI limit value < Displayed value (Or over in the positive value)	□□□□■ (Red LED on)

Three-level comparator mode

Results	Comparison formula	LED display
LO	Displayed value < LO limit value (Or over in the negative value)	■□□□□ (Red LED on)
OK	LO limit value ≤ Displayed value ≤ HI limit value	□□■□□ (Green LED on))
HI	HI limit value < Displayed value (Or over in the positive value)	□□□□■ (Red LED on)

Seven-level comparator mode (portion weighing mode)

Results	Comparison formula	LED display
None	Displayed value < Level 1 lower limit value (Or over in the negative value)	□□□□□ (No LEDs on)
LOLO (Level 1)	Displayed value < Level 2 lower limit value	■□□□□ (Red LED on)
LO (Level 2)	Displayed value < Level 3 lower limit value	□■□□□ (Yellow LED on)
OK (Level 3)	Level 3 lower limit value ≤ Displayed value ≤ Level 3 upper limit value	□□■□□ (Green LED on))
HI (Level 4)	Level 3 upper limit value < Displayed value	□□□■□ (Yellow LED on)
HIHI (Level 5)	Level 4 upper limit value < Displayed value	□□□□■ (Red LED on)
None	Level 5 upper limit value < Displayed value (Or over in the positive value)	□□□□□ (No LEDs on)

- The comparator values are common to the weighing and counting mode.
- Ignore the decimal point when setting the comparator values.
- The comparator values are maintained even if the power is turned OFF.
- Judgment order of comparison is from the top row to the bottom in the comparator mode tables
- The entered comparator values are not judged. Even if the upper limit value is less than the lower limit value, no error will be output.



10.2. Entering the comparator values

1. In the weighing mode, press and hold the **[SET]** key and press **[COMP]** key to enter the comparator value setting mode.
2. Enter the comparator values using the following keys.
 to To enter numerical value

1C To cancel settings

SET To switch between + and -

ENTER To store setting values

* Each time the **SET** key is pressed, “-” switches between being lit and off at the first digit. “-” being lit means a minus setting.

3. When the setting is complete, “End” is displayed and the scale returns to the weighing mode. (At this time, power-on-zero is not performed.)

Example of five-level comparator mode

With the HW-60KC, set as follows.

LOLO 8.500 kg
LO 10.000 kg
HI 10.500 kg
HIHI 12.000 kg

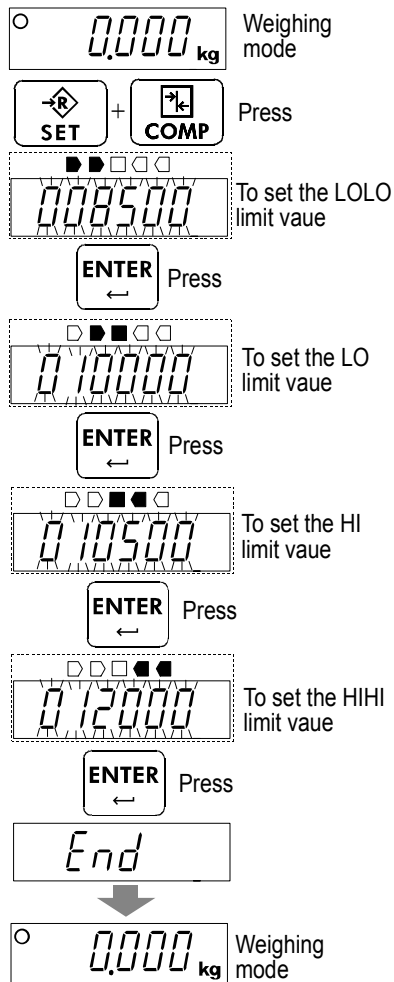

Example of three-level comparator mode (upper/lower limit mode)

With the HV-200KC, set as follows.

LO 148.85 kg
HI 152.5 kg

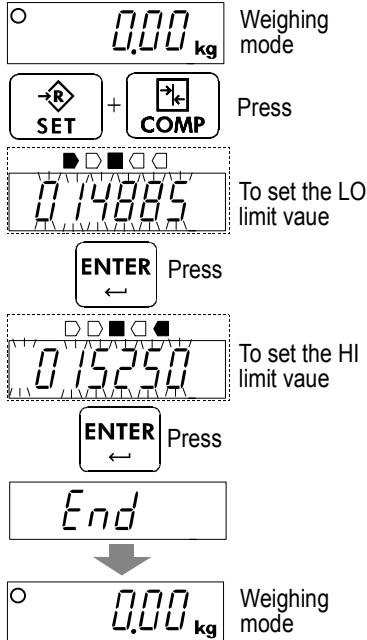

* With the HV-C models, the scale changes the minimum display digit depending on the display range. Enter 0 for the final digit.

Example of seven-level comparator mode (portion weighing mode)

With the HV-15KC, set as follows.

Level 1 (LOLO) 0.500 kg or more
Level 2 (LO) 1.000 kg or more
Level 3 (OK) 1.500 kg to 2.000 kg
Level 4 (HI) up to 2.500 kg
Level 5 (HIHI) up to 3.000 kg

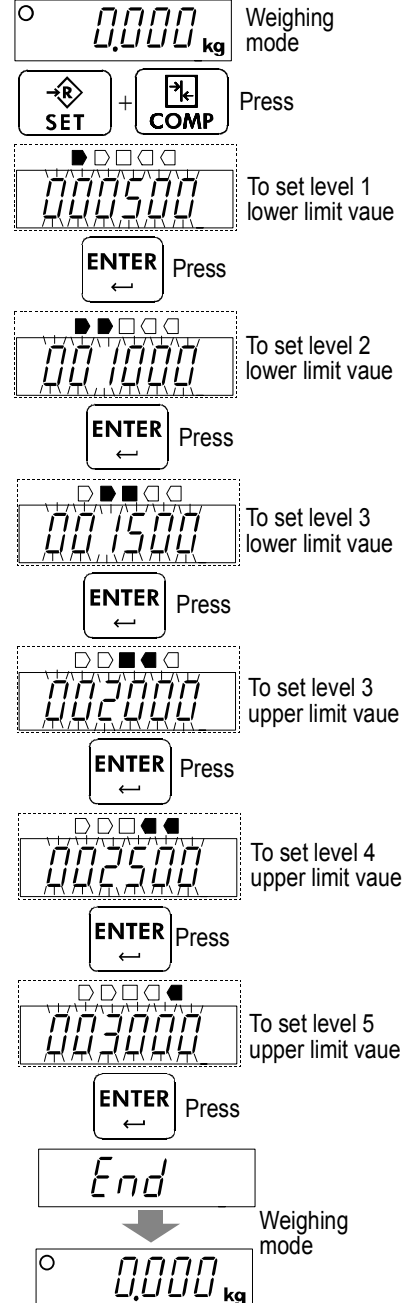



11. Auto-tare

The HV/HW-C/CP series has an auto-tare function to be used with the comparator mode enabled. Using this function in check weighing, the scale automatically tares, then displays “OK” for a certain amount of sample and repeats this process for the next weighing.

Start with display zero after tare operation. Place or take away objects until the comparison result will show OK. When the stable display is maintained for the duration specified in the function setting “*At-t*”, the scale will automatically tare the weight, show zero and be ready for next weighing.

❑ In some countries or areas, the auto-tare function can not be used on the Legal for Trade models and the selection in the function settings “*At*”, “*At-t*” and “*At-F*” is not available.

❑ To use the auto-tare function, set the function settings below.

CP 1: Compare all weighing data (other settings may be used depending on the application).

At 1: Auto-tare function enabled.

At-t 0 ~ 9: Select the timing to tare automatically to avoid the wrong tare operation, for example; too early to tare, to take a longer time to go to the next weighing.

❑ Take-away check weighing “*CP-P 1*” (Example with “*CP-L 0*” setting)

Take-away check weighing (negative comparison) is the way to compare the negative weight while taking away objects from a container. Set the function “*CP-P 1*” together with the auto-tare function enabled “*At 1*”. In this operation mode, the scale operates as “take-away the objects” → “OK and stable” → “auto-tare” → “take-away the objects” → …….

In this setting, the polarity of LOLO, LO, HI, and HIHI limit values are ignored and the scale shows the comparator results as below.

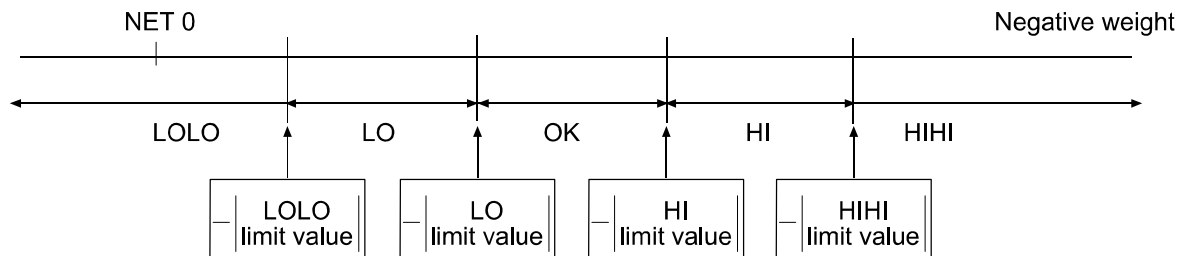

Note: To start the take-away check weighing, be sure to use the **TARE** key to tare the weight of the container filled with objects. The **ZERO** key may zero the display, and the scale goes below the zero point by taking out the objects. Then, the auto-tare function or **TARE** key does not work.

❑ When the function “*At-F 1* Tares the initial (container) weight.” is selected:

To start the auto-tare function, usually the container (filled with objects) will be placed on the weighing pan and its weight must be tared using the **TARE** key. When the function “*At-F 1*” is selected, the scale will tare the initial (container) weight automatically.

When all load on the weighing pan is removed, the scale will return to the zero point and the tare weight will be automatically cleared. If the scale does not return to the zero point, press the **ZERO** key to clear the tare weight.

❑ If the scale is equipped with the optional USB interface (HVW-02CBA) or optional RS-232C serial interface (HVW-03CJA), the OK weighing data can be output automatically. Set the function setting “*Prt 1*” or “*Prt 2*” to 7 or 8.



11.1. Built-in Printer for HV/HW-CP Series

- To use the printer, set the parameter of the "Print mode (`PrtP`)" in the function table.
- To print the date, set the parameter of the "Date (`CL Adj`)" in the function table.

Specification

Type	Line thermal dot type
Characters	32 characters per line (when using double height and width size, 16 characters per line)
Width of roll paper	58 mm
Accessories	Special roll paper (1 roll)

Consumables

Special roll paper	AX-PP147-S (set of 5 rolls)
--------------------	-----------------------------

Operation and Print Samples

- Press and hold the `SET` key and press the `PRINT` key. Paper feed is performed.
- The following example is when the print mode in the function settings is selected.

Printing example for `PrtP 1~8`

```

1.181 kg
590 PC

```

←Weight
←Number of times

Printing example for `StdP 3`

```

2016/ 8/31
14:56:51
1.180 kg

```

←Date
←Time
←Weight

Printing example for `StdP 1` (Id number = 000123)

```

2016/ 8/31
14:56:51
000123
1.180 kg

```

←Date
←Time
←Id
←Weight

Printing example for `Sum 4, PrtP 9`

```

2016/ 8/31
14:56:51
000123
001 1.181 kg

002 1.180 kg

003 1.180 kg

```

Printing is automatically done when accumulating.
Date, time and Id are only printed at first time.

Installing the roll paper

Step 1 Pull the printer cover toward you to open.

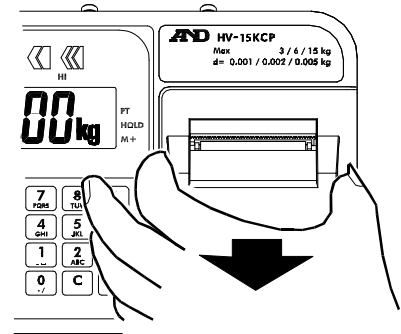

Step 2 Install the roll paper so that the end of the paper is at the top.

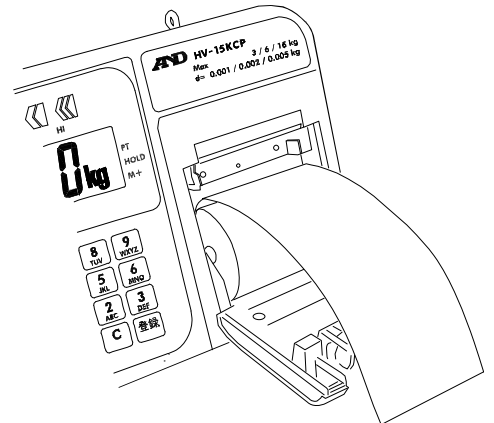

Step 3 Close the printer cover.

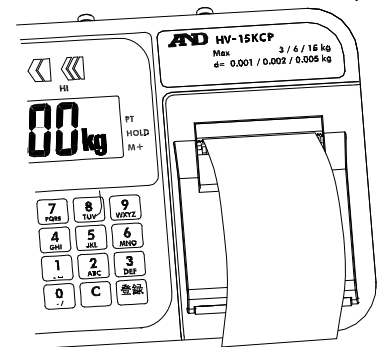

Step 4 When the roll paper is installed successfully, the built-in printer automatically feeds out the paper.

12. ID Number and GLP

The ID number is used to identify the scale when Good Manufacturing Practice (GMP) or Good Laboratory Practice (GLP) is used. The following GMP data is output to the built-in printer (HV/HW-CP series) or a personal computer using the RS-232C interface.

- The results of calibration (“Calibration report”)
- The results of calibration test (“Calibration test report”)
- The “Start block” and “End block” for GLP data

12.1. Setting the ID number

Step 1. With the power turned OFF, press and hold the **TARE** key and press the **ON/OFF** key to turn the power ON and enter the function setting mode. **bASFnC** appears.

Step 2. Press the **MODE** key several times to display **id**.

Step 3. Press the **ENTER** key. Enter the ID number using the following keys.

- 1M+** key To move the blinking digit to the left
 - PRINT** key To move the blinking digit to the right
 - Numerical keypad To set a value of the blinking digit
- See the table below for the “Display character set.”

Step 4. Press the **ENTER** key to store the settings. **id** appears after **End**.

Step 5. Press the **ON/OFF** key to turn the power OFF or press the **ZERO** key.

bASFnC

Press several times **MODE**

id

ENTER

000000

Set using corresponding keys.

ENTER

End

id

Display character set

0	1	2	3	4	5	6	7	8	9	-	↵	A	B	C	D	E	F	G	H	I	J	K	L	M	N	O	P	Q	R	S	T	U	V	W	X	Y	Z
0	1	2	3	4	5	6	7	8	9	-		A	b	c	d	E	F	G	H	,	u	v	L	ñ	n	o	P	q	r	S	t	U	ü	y		9	?

“↵” : Space

12.2. Setting the clock

The clock can only be set for built-in printer models (-CP models).

Step 1 Turn off the display.
Press and hold the **TARE** key and press the **ON/OFF** key to turn on the display and enter function setting mode. **bASFnC** appears.

Step 2 Press the **MODE** key several times to display **CL Adj**.

Step 3 Press the **ENTER** key to enter date confirmation mode.
* To only set time without changing date, press the **MODE** key

- Date setting mode -

Step 4 Press the **ENTER** key to enter date setting mode.
Set the date using the following keys.

M+ key	To move the blinking digit to the left
PRINT key	To move the blinking digit to the right
Numerical keypad	To set a value for the blinking digit
ZERO key	To proceed to step 5 without storing the setting.

Step 5 Press the **ENTER** key after finishing setting. A setting value is registered, and the scale proceeds to time confirmation mode after displaying **End**.
* To return to date confirmation mode, press the **MODE** key.

-Time setting mode -

Step 6 Press the **ENTER** key to enter time setting mode.
Set time using the following keys.

M+ key	To move the blinking digit to the left
PRINT key	To move the blinking digit to the right
Numerical keypad	To set a value for the blinking digit
ZERO key	To proceed to step 7 without storing the setting.

Step 7 Press the **ENTER** key after finishing setting to register the set value. The scale displays **CL Adj** after displaying **End**.

Step 8 Press the **ON/OFF** key to turn off the power or press the **ZERO** key

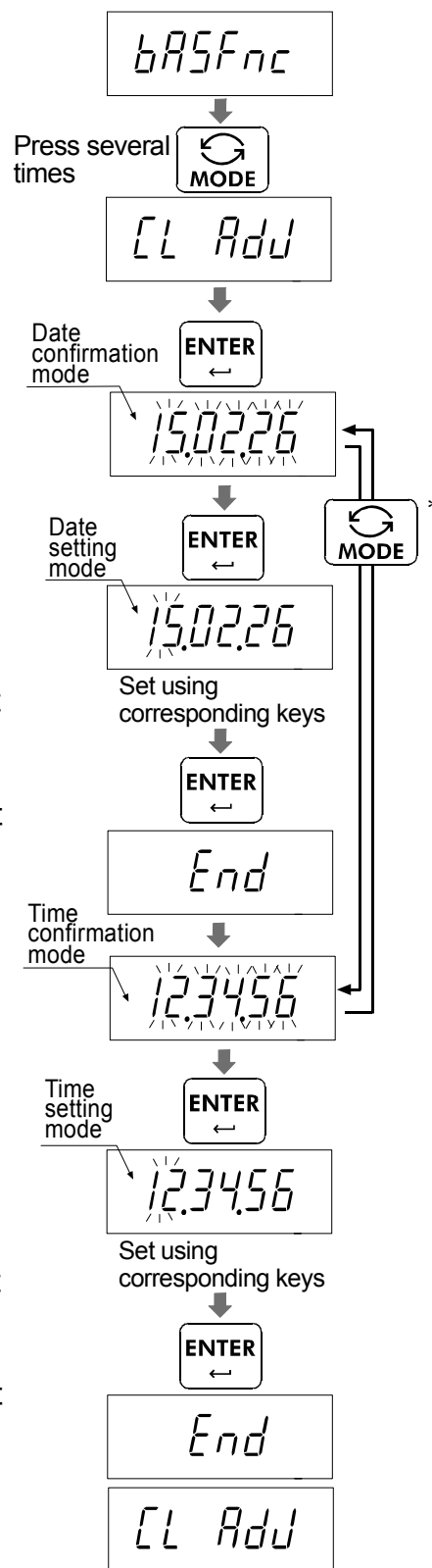



12.3. GMP report

- ❑ To print the GMP report to an AD-8127 printer, select the function setting “INF 1” and “INF 2 1” and use MODE 3 of the printer.
- ❑ To output the GMP report to a personal computer, select the function setting “INF 1” and “INF 2 2.”

Calibration report

Step 1. Perform calibration according to “13.2. Complete Calibration Procedure.”

Step 2. **End** appears when the calibration is complete.

Step 3. **GMP** appears and calibration report is output.

Step 4. **CAL** appears again. Remove the weight. Press the **ON/OFF** key to turn the power OFF or press the **CAL** switch.

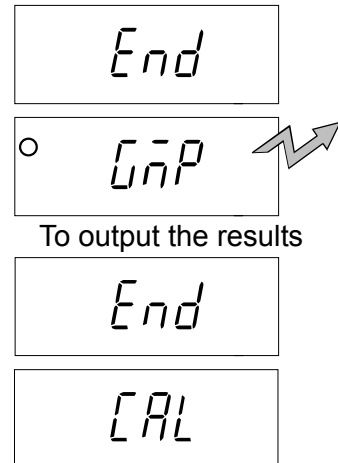

AD-8127 format “INF 1”

```

      A & D
MODEL  HV-15KC
S/N    6A6123456
ID     ABCDEF
DATE   2014/04/01
TIME   16:47:39
CALIBRATED(EXT.)
CAL.WEIGHT
      +15.000 kg
SIGNATURE
-----

```

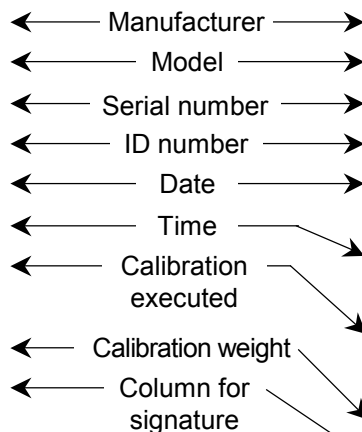

General format “INF 2”

```

.....A_&_D<CRLF>
MODEL_..._HV-15KC<CRLF>
S/N_..._6A6123456<CRLF>
ID_..._ABCDEF<CRLF>
DATE<CRLF>
<CRLF>
TIME<CRLF>
<CRLF>
CALIBRATED(EXT.)<CRLF>
CAL.WEIGHT<CRLF>
.....+15.000 kg<CRLF>
SIGNATURE<CRLF>
<CRLF>
<CRLF>
----- <CRLF>
<CRLF>
<CRLF>

```

␣: Space, ASCII 20h
 CR: Carriage return, ASCII 0Dh
 LF: Line feed, ASCII 0Ah

Calibration test report

The calibration test mode is used to compare a calibration weight with the calibration test data weighed by the scale.

❑ This test does not perform calibration.

Step 1. In the weighing mode, press and hold the **CAL** switch until **[[** appears, and release the switch.

❑ The calibration test mode is not available when the function setting “*INF1 0*” or “*INF2 0*” is selected.

Step 2. Press the **ENTER** key to display **[[0**.

Step 3. If necessary, change the value of the calibration weight as described in “13.2.4. Span Calibration”

Step 4. With nothing on the pan, press the **ENTER** key. The zero point is measured and the measured value with the unit “kg” is displayed for a few seconds. Then, the value of the calibration weight is displayed.

Step 5. Place a weight of the same value as displayed on the pan and press the **ENTER** key to measure it. The measured value with the unit “kg” is displayed for a few seconds.

Step 6. **End** appears.

Step 7. **GnP** appears and calibration test report is output.

Step 8. **[[** appears again. Remove the weight. Press the **ON/OFF** key to turn the power OFF or press the **CAL** switch.

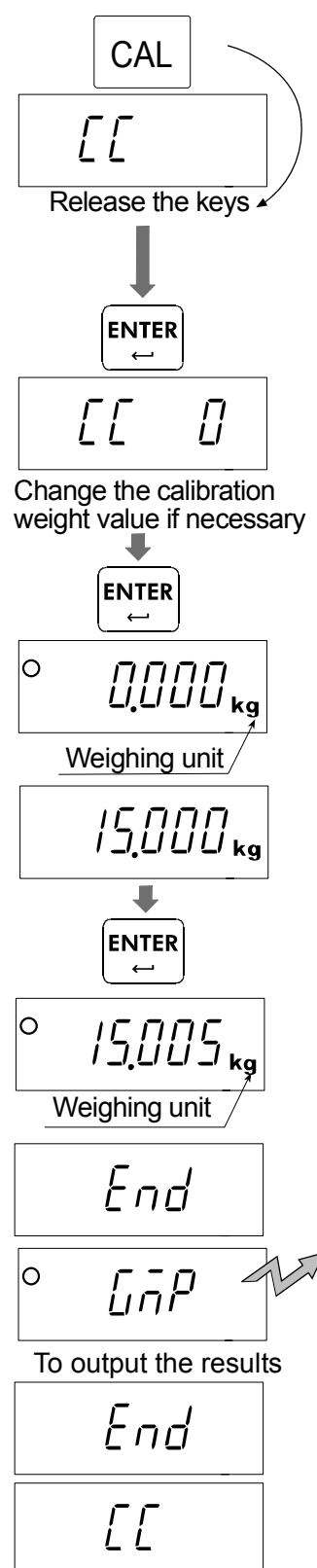

AD-8127 format “*inF | l*”

```

                A & D
MODEL      HV-15KC
S/N       6A6123456
ID        ABCDEF
DATE      2014/04/01
TIME      17:05:02
CAL.TEST(EXT.)
ACTUAL
          0.000 kg
          +15.005 kg
TARGET
          +15.000 kg
SIGNATURE
-----
    
```

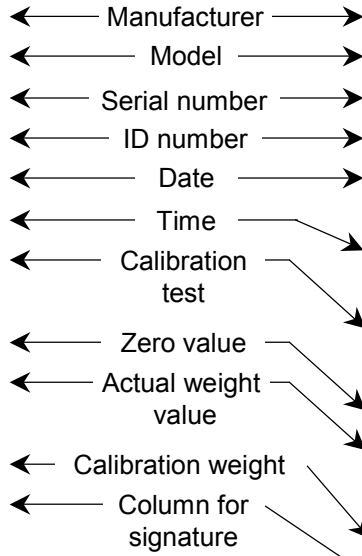

General format “*inF | z*”

```

_____A_&_D<CRLF>
MODEL___HV-15KC<CRLF>
S/N____6A6123456<CRLF>
ID_____ABCDEF<CRLF>
DATE<CRLF>
<CRLF>
TIME<CRLF>
<CRLF>
CAL.TEST(EXT.)<CRLF>
ACTUAL<CRLF>
_____0.000_kg<CRLF>
_____±15.005_kg<CRLF>
TARGET<CRLF>
          +15.000_kg<CRLF>
SIGNATURE<CRLF>
<CRLF>
<CRLF>
-----<CRLF>
<CRLF>
<CRLF>
    
```

_ : Space, ASCII 20h
 CR: Carriage return, ASCII 0Dh
 LF: Line feed, ASCII 0Ah

Output of “Title block” and “End block”

When weight values are recorded as the GMP report, “Title block” and “End block” are added at the beginning and at the end of a group of weight values.

Title block

Step 1. In the weighing mode, press and hold the **PRINT** key until **Start** appears, and release the key. The scale outputs the “Title block.” The scale automatically returns to the weighing mode.

Step 2. Press the **PRINT** key or select the auto-print mode to output the weight values.



Press and hold **PRINT**

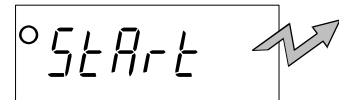

To output the "Title block"

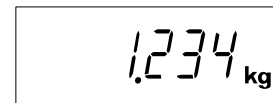

PRINT

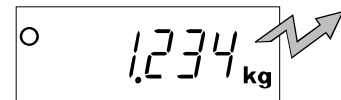

To output the weighing values

•
•
•

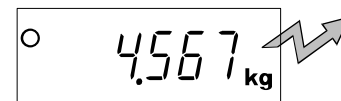

End block

Step 3. Press and hold the **PRINT** key until **rEccEnd** appears, and release the key.
The scale outputs the "End block."

Press and hold 

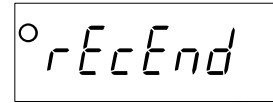

To output the "End block"



Step 4. The scale automatically returns to the weighing mode.

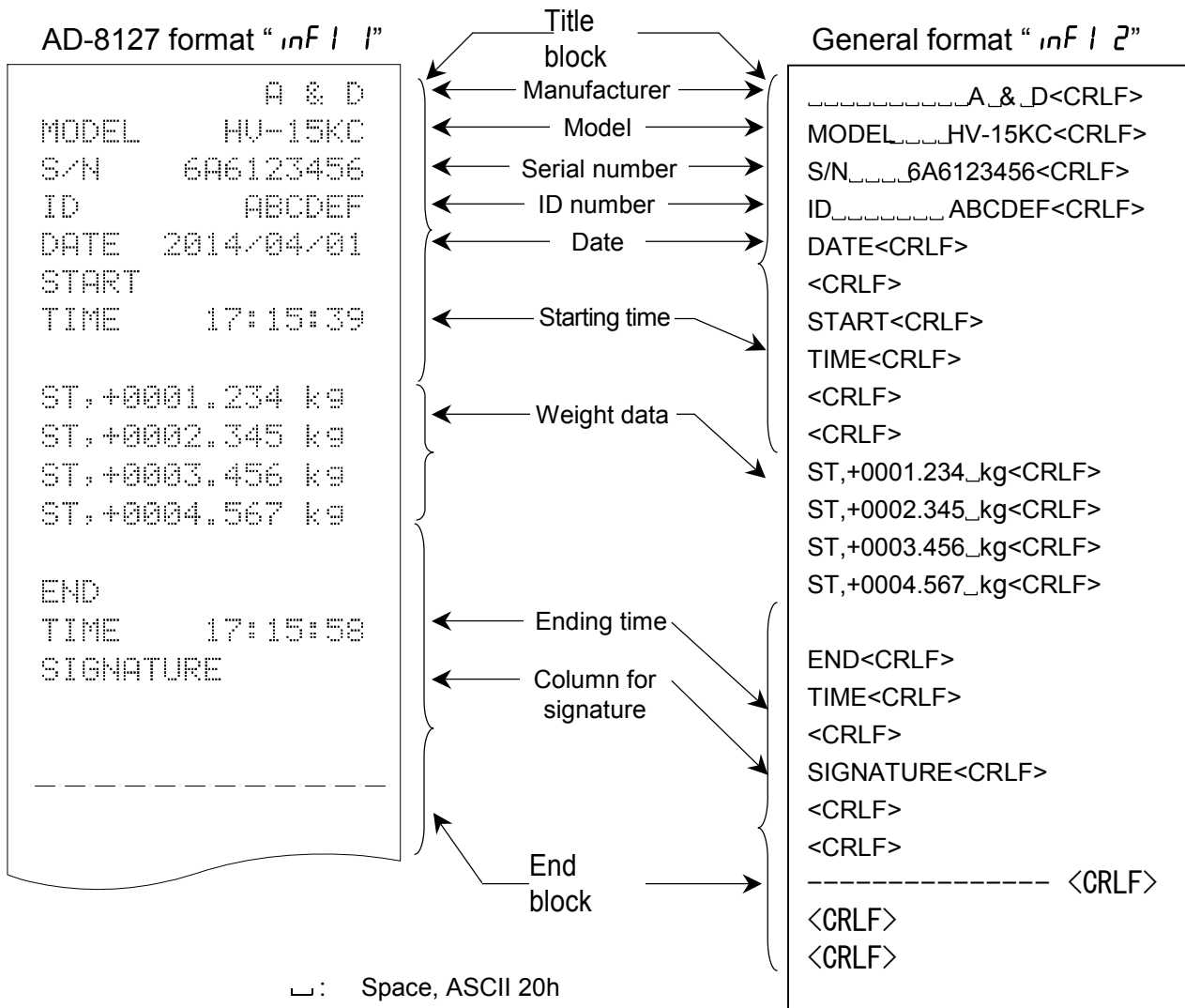



13. Calibration (Adjusting the Scale)

- The scale is an instrument which weighs the "weight" and displays its "mass". Calibration is the adjustment function so that the scale can weigh correctly.
- Three steps of calibration are available

Gravity Acceleration Correction ... The function to correct the scale's local gravity acceleration, so that the scale functions correctly when the calibrated scale has been moved to a distant place.
Refer to the "Gravity Acceleration Table" on the next page.

Calibration of the Zero Point The function to adjust the zero point, so that the zero point mark is displayed when there is nothing on the pan.

Comment The zero point is the fundamental starting point to weigh anything and influences the performance of scale.

Span Calibration..... The function to adjust the span with a calibrated mass, so that the scale can accurately weigh anything within the weighing capacity.

Comment Span means the range of weighing capacity. Use a calibration mass heavier than two thirds of the weighing capacity.

Caution

- **Check the accuracy of weighing periodically. Calibrate the scale, if it has been moved to another location or the environment has changed.**
- **Gravity acceleration correction is not required, when the scale is calibrated with the calibration mass at the place where the scale is used.**



13.1. Gravity Acceleration Table

Amsterdam	9.813 m/s ²	Manila	9.784 m/s ²
Athens	9.800 m/s ²	Melbourne	9.800 m/s ²
Auckland, NZ	9.799 m/s ²	Mexico	9.779 m/s ²
Bangkok	9.783 m/s ²	Milan	9.806 m/s ²
Birmingham	9.813 m/s ²	New York	9.802 m/s ²
Brussels	9.811 m/s ²	Oslo	9.819 m/s ²
Buenos Aires	9.797 m/s ²	Ottawa	9.806 m/s ²
Calcutta	9.788 m/s ²	Paris	9.809 m/s ²
Chicago	9.803 m/s ²	Rio de Janeiro	9.788 m/s ²
Copenhagen	9.815 m/s ²	Rome	9.803 m/s ²
Cyprus	9.797 m/s ²	San Francisco	9.800 m/s ²
Djakarta	9.781 m/s ²	Singapore	9.781 m/s ²
Frankfurt	9.810 m/s ²	Stockholm	9.818 m/s ²
Glasgow	9.816 m/s ²	Sydney	9.797 m/s ²
Havana	9.788 m/s ²	Tainan	9.788 m/s ²
Helsinki	9.819 m/s ²	Taipei	9.790 m/s ²
Kuwait	9.793 m/s ²	Tokyo	9.798 m/s ²
Lisbon	9.801 m/s ²	Vancouver, BC	9.809 m/s ²
London (Greenwich)	9.812 m/s ²	Washington, DC	9.801 m/s ²
Los Angeles	9.796 m/s ²	Wellington, NZ	9.803 m/s ²
Madrid	9.800 m/s ²	Zurich	9.807 m/s ²

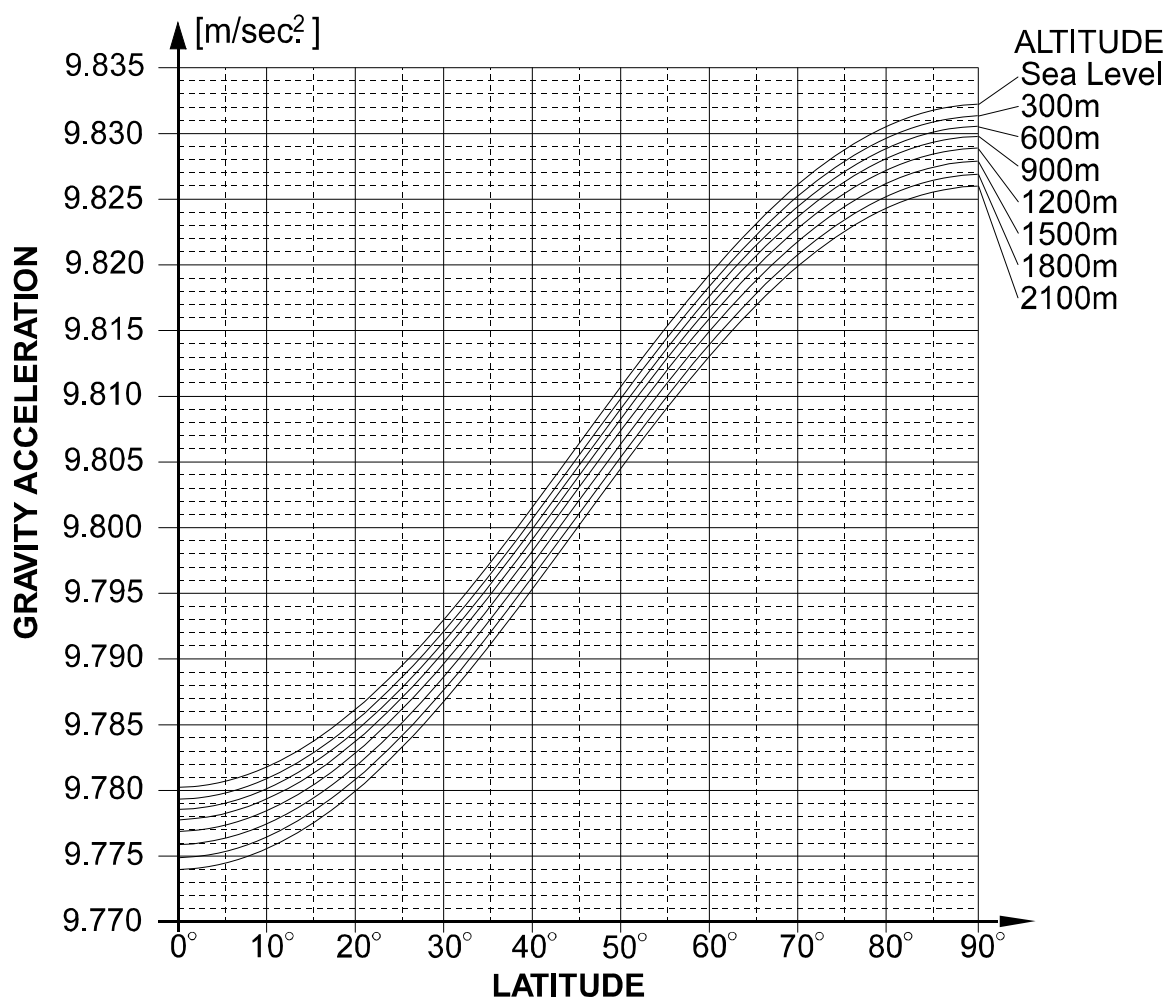



13.2. Complete Calibration Procedure

13.2.1. Gravity Acceleration Correction

- Step 1 Turn on the display.
Open the rear cover of the display unit. Locate the **CAL** switch inside.
Press the **CAL** switch to enter the calibration mode.
Then **ERR 0** is displayed.

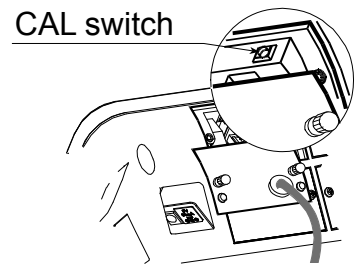

- Step 2 Press the **MODE** key to enter the gravity acceleration correction mode. Press the **ENTER** key to make the numerical value blink and proceed to input mode.

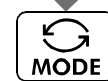
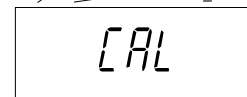

- Step 3 Set your local gravity acceleration using the numerical keypad.

Enter using numerical keypad



- Step 4 Press the **ENTER** key to store the new value.
The display returns to gravity acceleration display after displaying **End**.

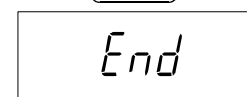

- Step 5 Press the **CAL** switch again to finish gravity acceleration correction.



 CAL switch



The power is automatically turned off.

13.2.2. Preparation

- Step 6 Confirm the environmental conditions as follows:
Maintain a constant temperature and stable power.
Install the scale on a solid floor where there is no draft, vibration, strong magnetic fields or direct sunlight.
Refer to "4.1. Installing the Scale".
- Step 7 Keep the display turned on for at least 30 minutes to warm up the scale.

13.2.3. Calibration of the Zero Point

- Step 8 After 30-minute warm up, press the **CAL** switch to display **CAL**.
Press the **ENTER** switch to display **CAL 0**.
- Step 9 Confirm that nothing is placed on the pan. Wait for the stability mark to be displayed. Press the **ENTER** key. The scale stores the current condition as the zero point.
- Step 10 Calibration of the zero point is finished. To exit the calibration mode, proceed to step 14.

13.2.4. Span Calibration

- Step 11 Set the value of the calibration mass using the numerical keypad. (The initial value depends on the scale model.)
- Step 12 Place the mass on the pan which was set at step 11. Wait for the stability mark to be displayed. Press the **ENTER** key. The scale then calculates the span and stores it.
- Step 13 The scale displays **CAL** after displaying **End** to finish setting. Remove the mass from the pan.
- Step 14 Press the **CAL** switch to finish calibration.

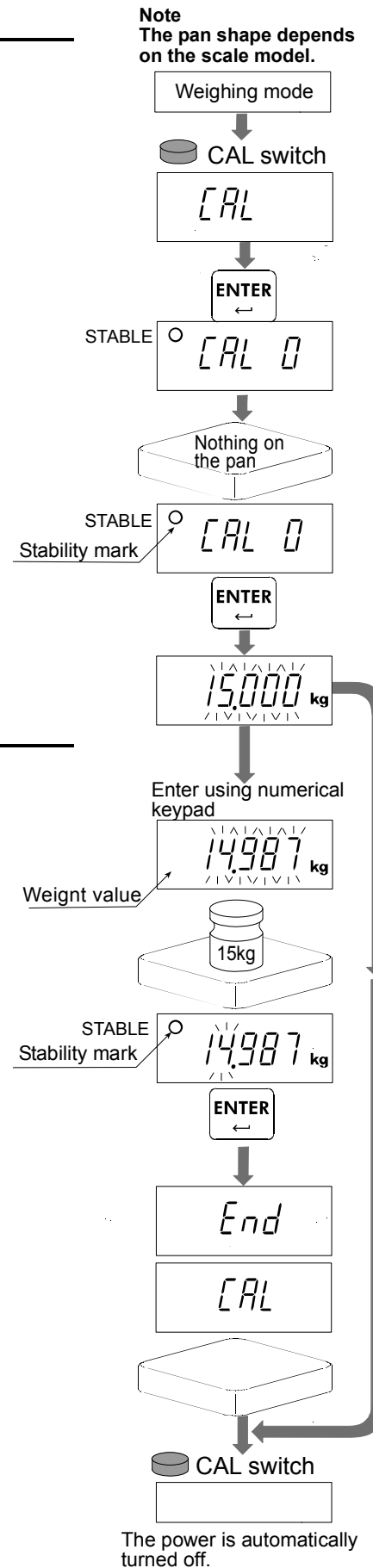



14. Function Table

- ❑ The function table is used to store and refer items that determine the performance of the scale. Each item has a parameter.
- ❑ The parameters are stored in the scale even if the power is removed.

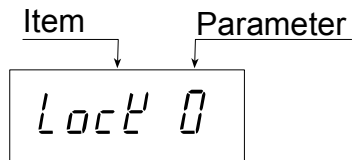

14.1. Parameter Setting Procedure

Step 1 Turn off the display.

Press and hold the **TARE** key and press the **ON/OFF** key to display software version **P-XXX**.

Press the **MODE** key to enter function setting mode.

Class **bASFnC**.

Step 2 Press the **MODE** key to select the desired class, and then press the **ENTER** key.

Step 3 The first item of class is displayed. Press the **MODE** key to select the desired item, and then enter a value using numerical keypad.

Step 4 Press the **ENTER** key to store. The display returns to class after displaying **End**.

Step 5 Press the **ZERO** key to return to normal weighing mode.

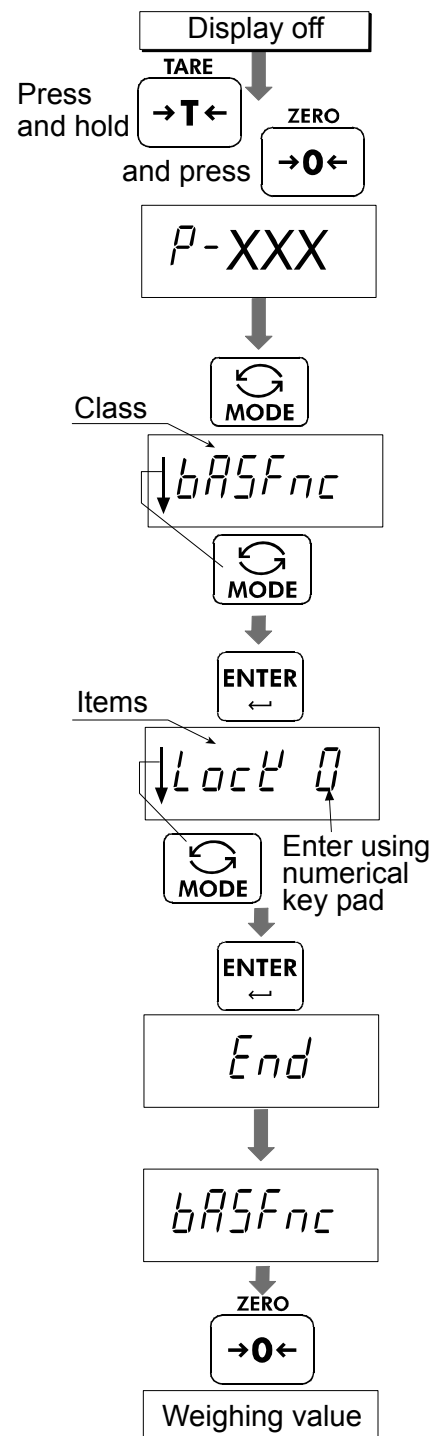



14.2. Parameter List

Class	Items	Parameter	Details and usage
bASFnc	Key lock <i>Lock</i>	0 ■	Functions with all the keys
		1	Functions with the ON/OFF, ZERO, TARE, HOLD, M+ and PRINT key
		2	Functions with the ON/OFF, ZERO, TARE key
	Automatic power off <i>PoFF</i>	0 ■	OFF
		1	After 5 minuets
		2	After 10 minuets
		3	After 15 minuets
		4	After 30 minuets
	Automatic power on <i>P-on</i>	0 ■	OFF
		1	ON * The scale automatically turns the power on by connecting to the power using the AC adapter.
	Zero tracking <i>trc</i>	0	OFF
		1 ■	ON
	Stability band width <i>St-b</i>	0 ■	±0.5 digit
		1	±1 digit
		2	±2 digits
	Stability band time <i>St-t</i>	0	0.5 second
		1 ■	1.0 seconds
		2	1.5 seconds
	Weighing stabilization level <i>cond</i>	0	Fast
		1	
		2 ■	
		3	
		4	Slow
	Back light control <i>Lite</i>	0	Always turned off
		1	Always lit
		2 ■	Turns off 5 seconds after stabilizing
		3	Turns off 10 seconds after stabilizing
		4	Turns off 15 seconds after stabilizing
		5	Turns off 30 seconds after stabilizing
	Back brightness <i>L-i</i>	0	Dark
1			
2 ■			
3			
4		Bright	
Decimal point <i>Pnt</i>	0 ■	Dot (.)	
	1	Comma (,)	
Automatic tare <i>Rt</i>	0 ■	OFF	
	1	ON	

■ : factory settings

"Nearly-zero" is within ± 5 digits (five times the minimum mass that can be weighed) from zero point in the unit kg.

Class	Items	Parameter	Details and usage
bR5Fnc	Interval until making automatic tare <i>Rt-t</i>	0	0 second
		1	0.5 second
		2 ■	1.0 second
		3	1.5 seconds
		4	2.0 seconds
		5	2.5 seconds
		6	3.0 seconds
		7	4.0 seconds
		8	5.0 seconds
		9	10 seconds
	Tare on initial load <i>Rt-F</i>	0 ■	OFF
		1	ON
	Accumulation mode <i>Sum</i>	0	OFF
		1 ■	Accumulates by M+ key when the value is +, excluding near zero
		2	Accumulates by M+ key when the value is + or -, excluding near zero
		3	Accumulates automatically when the value is +, excluding near zero
	Hold condition <i>Hold</i>	0 ■	OFF
		1	Holds or releases by the HOLD key
		2	Automatically holds when detecting a stabilization
	Buzzer <i>buZZ</i>	0 ■	Not sounded
			Method for LED to be lit* When lighting up the LED registered to be lit, the buzzer sounds. Set it using the numerical keypad. The LEDs at 1:LOLO, 2:LO, 3:OK, 4:HI or 5:HIHI are lit.
	External contact input 1 <i>Con1</i>	0 ■	None
		1	ON/OFF
		2	ZERO
		3	TARE
		4	MODE
		5	PRINT
		6	M+
External contact input 2 <i>Con2</i>	0 ■	None	
	1	ZERO	
	2	TARE	
	3	MODE	
	4	PRINT	
	5	M+	
CP Fnc	Comparator judgment value <i>CP-L</i>	0 ■	Five-level comparator
		1	Three-level comparator (upper and lower limits)
		2	Seven-level comparator (portion weighing)

■ : factory settings

"Nearly-zero" is within ± 5 digits (five times the minimum mass that can be weighed) from zero point in the unit kg.

Class	Items	Parameter	Details and usage
CP Func	Comparator judgment condition [P	0	OFF
		1 ■	Compares all
		2	Compares all the stabilized data
		3	Compares all the data, excluding from -4 digits to +4 digits
		4	Compares the stabilized data, excluding from -4 digits to +4 digits
		5	Compares all the data more than +5 digits
	Comparator brightness [P- ,	0	 Dark Bright
		1	
		2 ■	
		3	
	Comparator reversal [P-P	0 ■	OFF
		1	ON
S,IF	Baud rate 1 bP51 (OP-ch1)	0 ■	2400
		1	4800
		2	9600
	Bit length, parity1 bLp1 (OP-ch1)	0 ■	7bit/even
		1	7bit/odd
		2	8bit/non
	Communication format 1 S,IF1 (OP-ch1)	0 ■	Format 1
		1	Format 1, existing returned value
		2	UFC
	Baud rate 2 bP52 (OP-ch2)	0 ■	2400
		1	4800
		2	9600
	Bit length, parity 2 bLPr2 (OP-ch2)	0 ■	7bit/even
		1	7bit/odd
		2	8bit/non
	Communication format 2 S,IF2 (OP-ch2)	0 ■	Format 1
		1	Format 1, existing returned value
		2	UFC
Built-in printer communication format S,IFP	0 ■	Format 1	
	1	UFC	
dout	Output mode 1 PrL1 (OP-ch1)	0	Stream mode (commands)
		1	Commands (Output by a "Q" command from the OP-ch1 or OP-ch2)
		2	Commands (Output by a "Q" command from the OP-ch1)
		3	Commands (Output by a "Q" command from the OP-ch2)
		4 ■	Outputs by the [PRINT] key (commands)
		5	Outputs data at auto print setting, +5 digits or more and stabilization (commands)
		6	Outputs data at auto print setting, +5 digits or more, or -5 digits or less and stabilization (commands)
		7	Outputs data at auto print setting, +5 digits or more and stabilization when the comparator is OK (commands)
		8	Outputs data at auto print setting, +5 digits or more, or -5 digits or less and stabilization when the comparator is OK (commands)
	9	Prints an accumulation value when the accumulation operation is made (commands)	
			* Output depending on output command (output command: Q,A,N,?H3,?H2,?H1,?L1,?L2,?L3)

■ : factory settings

Class	Items	Parameter	Details and usage	
dout	Time and date adding <i>Std1</i> (OP-ch1)	0 ■	Do not output the date and time	
		1	Outputs time (ESC T) *2	
		2	Outputs date (ESC D) *2	
		3	Outputs the date and time (ESC D,ESC T) *2	
		4	Outputs time (RTC) *1	
		5	Outputs date (RTC) *1	
		6	Outputs the date and time (RTC) *1	
	ID number adding <i>Std1</i> (OP-ch1)	0 ■	Do not output the ID	
		1	Outputs the ID	
	GMP output <i>Inf1</i> (OP-ch1)	0 ■	Not output	
		1	Output (ESC D, ESC T output) *2 AD-8127 format	
		2	Output (DATE,TIME output) General format	
	Output mode <i>Print2</i> (OP-ch2)	0	Stream mode (commands)	* Output depending on output command (output command: Q,A,N,?H3,?H2,?H1,?L1,?L2,?L3)
		1	Commands (Output by a "Q" command from the OP-ch1 or OP-ch2)	
		2	Commands (Output by a "Q" command from the OP-ch1)	
		3	Commands (Output by a "Q" command from the OP-ch2)	
		4 ■	Outputs by the PRINT key (commands)	
		5	Outputs data at auto print setting, +5 digits or more and stabilization (commands)	
		6	Outputs data at auto print setting, +5 digits or more, or -5 digits or less and stabilization (commands)	
		7	Outputs data at auto print setting, +5 digits or more and stabilization when the comparator is OK (commands)	
		8	Outputs data at auto print setting, +5 digits or more, or -5 digits or less and stabilization when the comparator is OK (commands)	
		9	Prints an accumulation value when the accumulation operation is made (commands)	
	Time and date adding <i>Std2</i> (OP-ch2)	0 ■	Do not output the date and time	
		1	Outputs time (ESC T) *2	
		2	Outputs date (ESC D) *2	
		3	Outputs the date and time (ESC D,ESC T) *2	
		4	Outputs time (RTC) *1	
		5	Outputs date (RTC) *1	
		6	Outputs the date and time (RTC) *1	
	ID number adding 2 <i>Std2</i> (OP-ch2)	0 ■	Do not output the ID	
		1	Outputs the ID	
	GMP output 2 <i>Inf2</i> (OP-ch2)	0 ■	Not output	
		1	Output (ESC D,ESC T output) *2 AD-8127 format	
2		Output (DATE,TIME output) General format		
		3	Output (RTC output) *1	

■: factory settings

* 1 RTC: built-in clock

* 2 ES (T, ESC 1)

Use date and time of calendar function of the AD-8127.

Class	Items	Parameter	Details and usage
dout	Built-in printer print mode <i>PrtP</i>	0	Not printed
		1	Commands (print by a "Q" command from the OP-ch1 or OP-ch2) * Print depending on output command (output command: Q,A,N,?H3,?H2,?H1,?L1,?L2,?L3)
		2	Commands (print by a "Q" command from the OP-ch1)
		3	Commands (print by a "Q" command from the OP-ch2)
		4 ■	Prints by the PRINT key
		5	Prints data at auto print setting, +5 digits or more and stabilization
		6	Prints data at auto print setting, +5 digits or more, or -5 digits or less and stabilization
		7	Prints data at auto print setting, +5 digits or more and stabilization when the comparator is OK
		8	Prints data at auto print setting, +5 digits or more, or -5 digits or less and stabilization when the comparator is OK
		9	Prints an accumulation value when the accumulation operation is made
	Time and date adding <i>StdP</i>	0 ■	Do not print the date and time
		1	Prints time (RTC)
		2	Prints date (RTC)
		3	Prints the date and time (RTC)
	ID number adding <i>SidP</i>	0 ■	Do not print the ID
		1	Prints the ID
	GMP print <i>inFP</i>	0 ■	Not print
		1	Print (RTC output)
	Double height and width size <i>dScP</i>	0 ■	Standard
		1	Double height and width size
	Built-in printer label mode <i>LAbL</i>	0 ■	Thermal paper
		1	Label
	Line feed of printer <i>PrLF</i>	0	0 lines
		1	1 line
		2 ■	2 lines
		5	5
		9	9 lines

■ : factory settings

* Settings for RTC and RTC output (clock function) is available only for built-in printer model (-CP model)

15. Options

The scale is equipped with OP-ch1 and OP-ch2 for communication options, and OP-ch3 only for comparator relay output.

Those options can be combined freely. Combinations such as HVW-02BC×2, HVW-02CB + HVW-03C or HVW-03CJA×2 are possible.

Only the HVW-04C can be installed with the slot for the OP-ch3.

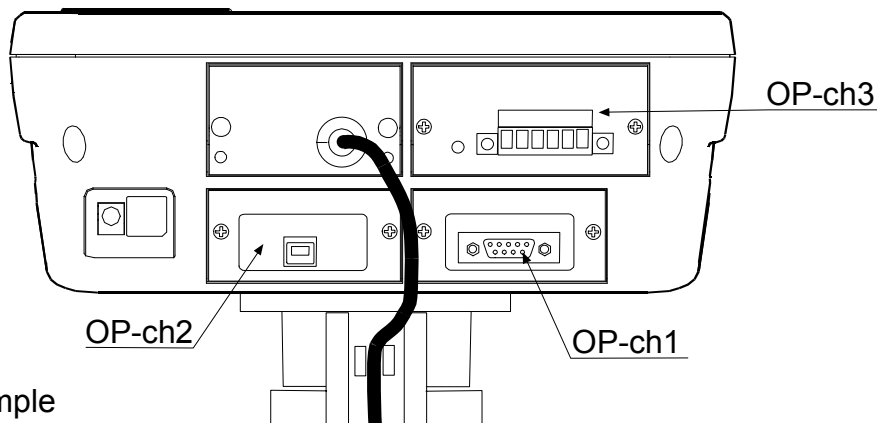

Installation example

OP-ch1: HVW-03C

OP-ch2: HVW-02CB

OP-ch3: HVW-04C

15.1. Installing an option

Remove the two M3 screws at both side on the panel, and then remove the panel from the display unit.

Connect the cable located inside the display unit to the connector on the option panel. Firmly secure the option to the display unit using the two M3 screws.

15.2. HVW-02CB USB Interface

The HVW-02CB is available for duplex communication using a USB interface.

The connector is type B. To connect the HVW-02CB to a PC, “type A male - type B female” cable sold separately can be used.

When confirming the communication format, refer to “15.5. Communication format”.

To communicate between the scale and PC using the USB interface, it is necessary to install the specified driver for the HVW-02CB. Download the driver from the A&D website.

The HVW-02CB can only be connected with a PC. Do not take power from the USB terminal. Do not connect a device other than a PC to the USB terminal. Doing so may cause malfunctions.



15.3. HVW-03C RS-232C Interface

The HVW-03C is available for duplex communication using RS-232C interface. The DCE (Data Communication Equipment) connector is type DSUB-9P. To connect the HVW-03C to an external device, it is necessary to use a communication cable sold separately.

AX-KO2466-200(2m) / -500(5m) / -1000(10m)

When confirming the communication format, refer to “15.5. Communication format”.

Pin assignment

Pin No.	Signal name	Direction	Description
1	—	—	No connection
2	TXD	→	Transmit data
3	RXD	←	Receive data
4	—	—	No connection
5	GND	—	Signal ground
6	DSR	→	Data set ready
7	RTS	←	Request to send
8	CTS	→	Clear to send
9	—	—	Used internally

Names other than TXD and RXD are for the DTE side.

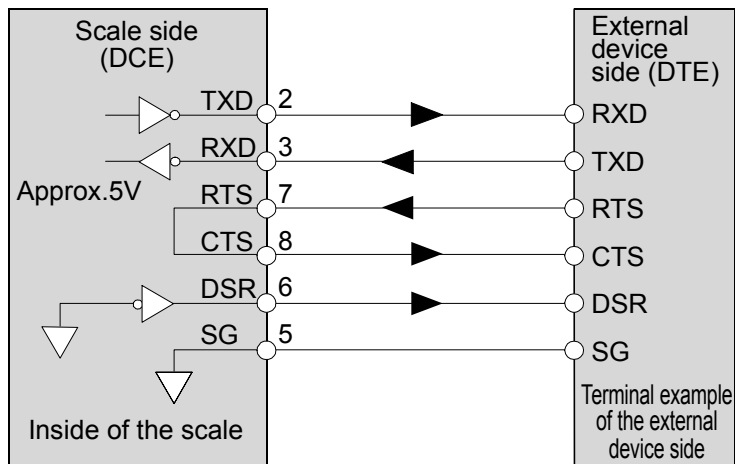



15.4. HVW-04C Comparator Relay Output / Buzzer / Contact Input

- ❑ Maximum voltage: 50V DC Attached terminal
- ❑ Maximum current: 100 mA DC Manufacturer: PHOENIX
- ❑ Maximum ON resistance: 8 Ω Model name: MSTB 2.5/ 6-STF-5.08

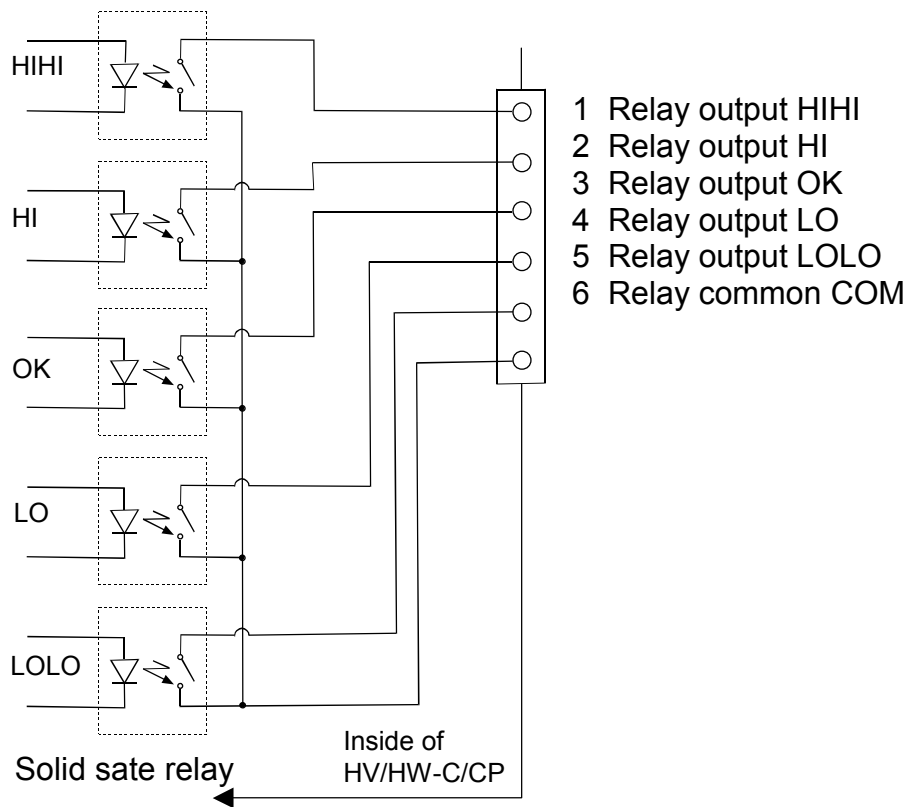

- ❑ Terminal names and wiring example of external contact input plug

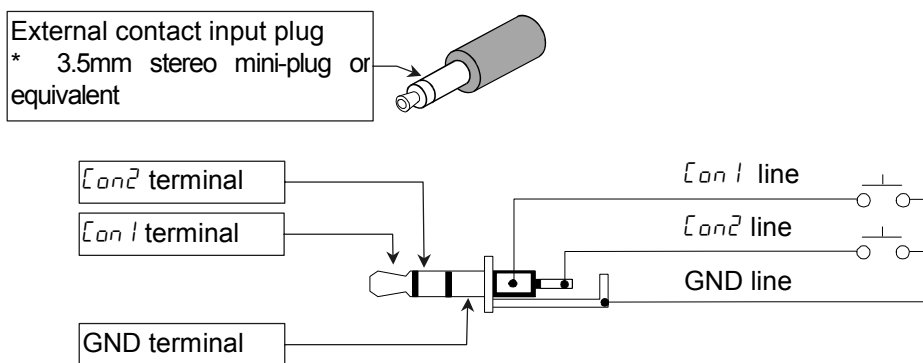



15.5. Communication format

Data format

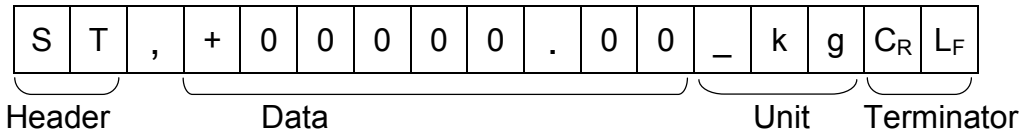

- There are 4 headers for the weighing data.

ST: Stable weighing data
 QT: Stable counting data
 US: Unstable weighing data
 OL: Out of weighing range

- The data consists of 9 characters including the polarity and decimal point.

- There are 5 units.

_ k g: Weighing mode "kg"
 _ l b: Weighing mode "lb"
 _ o z: Weighing mode "oz"
 _ l b-oz: Weighing mode "lb-oz"
 _ PC: Counting mode "pcs"

- As a terminator, C_RL_F is always output.

- Data example

Weighing data "kg" (+)	S	T	,	+	0	0	1	2	.	3	4	5	_	k	g	C _R	L _F
Counting data "pcs" (+)	Q	T	,	+	0	0	0	1	2	3	4	5	_	P	C	C _R	L _F
Out of weighing range (+)	O	L	,	+	9	9	9	9	.	9	9	9	_	k	g	C _R	L _F
HV-C model	S	T	,	+	0	0	1	2	.	3	4	_	_	k	g	C _R	L _F

When changing number of digits of the minimum display

Data output mode (Prt)

- Command mode

The scale is controlled by commands that come from an external device such as a personal computer. For details, refer to "15.5.1. Command mode".

- Stream mode (Prt 0)

Data is sent continuously. The data update rate is approximately 10 times per second, the same as the display refresh rate.

There will be no output during the setting procedures.

- Print key mode (Prt 4)

When the weight display is stable, data is sent by pressing the PRINT key. At this time, the display flashes once to indicate that the data is sent.

- Auto-print mode + data (Prt 5)

When the weight display is stable at +5d (d = minimum display in kg) and above, the data is sent. The next transmission can not occur until after the weight display falls +4d or below.

Auto-print mode +/- data (Prt | 6)

When the weight display is stable at $\pm 5d$ (d = minimum display in kg) and above +5d or below -5d, the data is sent. The next transmission can not occur until after the weight display falls between -4d and +4d.

Auto-print mode + data and OK (Prt | 7)

When the weight display is stable and OK as a comparison result at +5d (d = minimum display in kg) and above, the data is sent. The next transmission can not occur until after the weight display falls +4d or below.

Auto-print mode +/- data and OK (Prt | 8)

When the weight display is stable and OK as a comparison result at $\pm 5d$ (d = minimum display in kg) and above +5d or below -5d, the data is sent. The next transmission can not occur until after the weight display falls between -4d and +4d.

Baud Rate (bPS)

When using HVW-03CJA, select the baud rate according to the device to be connected.

2400 bps (bPS 0) Select 2400 bps to connect to an AD-8127 printer.

4800 bps (bPS 1)

9600 bps (bPS 2)

15.5.1. Command mode

In the command mode, the scale is controlled by commands that come from an external device such as a personal computer.

Command List

Command	Description	Remarks
Q	Send data immediately.	
Z	Zero the scale when the weight is stable.	Same as the ZERO key.
T	Tare the scale when the weight is stable.	Same as the TARE key.
U	Switch the weighing unit.	Same as the MODE key.
CT	Clears tare	
PT	Sets preset tare	PT,+000000<CR><LF>
A	Outputs accumulation values	
N	Outputs the number of accumulations	
CA	Clears accumulation	
ID	Sets ID number	ID: xxxxxx<CR><LF>
?ID	Requests ID number	

Command	Description	Remarks
?PT	Outputs preset tare value	
?H3	When the five-level comparator mode is used: Not used When the three-level comparator mode is used: Not used When the seven-level comparator mode is used: Send the current level 5 upper limit value.	Send a setting value. Function settings Five-level ($[P-L \ 0]$) Three-level ($[P-L \ 1]$) Seven-level ($[P-L \ 2]$)
?H2	When the five-level comparator mode is used: Send the current HHI limit value. When the three-level comparator mode is used: Send the current HI limit value. When the seven-level comparator mode is used: Send the current level 4 upper limit value.	
?H1	When the five-level comparator mode is used: Send the current HI limit value. When the three-level comparator mode is used: Not used When the seven-level comparator mode is used: Send the current level 3 upper limit value.	
?L1	When the five-level comparator mode is used: Send the current LO limit value. When the three-level comparator mode is used: Not used When the seven-level comparator mode is used: Send the current level 3 lower limit value.	
?L2	When the five-level comparator mode is used: Send the current LOLO limit value. When the three-level comparator mode is used: Send the current LO limit value. When the seven-level comparator mode is used: Send the current level 2 lower limit value.	
?L3	When the five-level comparator mode is used: Not used When the three-level comparator mode is used: Not used When the seven-level comparator mode is used: Send the current level 1 lower limit value.	
H3	When the five-level comparator mode is used: Not used When the three-level comparator mode is used: Not used When the seven-level comparator mode is used: Set the level 5 upper limit value.	

Command	Description	Remarks
H2	When the five-level comparator mode is used: Set the HIHI limit value. When the three-level comparator mode is used: Set the HI limit value. When the seven-level comparator mode is used: Set the level 4 upper limit value.	
H1	When the five-level comparator mode is used: Set the HI limit value. When the three-level comparator mode is used: Not used When the seven-level comparator mode is used: Set the level 3 upper limit value.	
L1	When the five-level comparator mode is used: Set the LO limit value. When the three-level comparator mode is used: Not used When the seven-level comparator mode is used: Set the level 3 lower limit value.	
L2	When the five-level comparator mode is used: Set the LOLO limit value. When the three-level comparator mode is used: Set the LO limit value. When the seven-level comparator mode is used: Set the level 2 lower limit value.	
L3	When the five-level comparator mode is used: Not used When the three-level comparator mode is used: Not used When the seven-level comparator mode is used: Set the level 1 lower limit value.	

Command examples (“_” indicates “Space” (20H).)

The examples below are for the function setting “5 iF l l” (Reply to commands).

Request the weight data.

Command

Q	C _R	L _F
---	----------------	----------------

Reply

S	T	,	+	0	0	1	2	.	3	4	5	_	k	g	C _R	L _F
U	S	,	+	0	0	0	7	.	8	9	0	_	k	g	C _R	L _F
O	L	,	+	9	9	9	9	.	9	9	9	_	k	g	C _R	L _F

 Stable positive data
Unstable positive data
‘E’ display

Zero the scale. (No reply for the function setting “5 iF l 0”.)

Command

Z	C _R	L _F
---	----------------	----------------

Reply

Z	C _R	L _F
---	----------------	----------------

 The scale is in a condition that zero operation is possible.

- ❑ Tare the scale. (No reply for the function setting “5 , F 1 0 “.)

Command

T	C _R	L _F
---	----------------	----------------

Reply

T	C _R	L _F
---	----------------	----------------

 The scale is in a condition that tare operation is possible.

- ❑ Switch the weighing unit. (No reply for the function setting “5 , F 1 0 “.)

Command

U	C _R	L _F
---	----------------	----------------

Reply

U	C _R	L _F
---	----------------	----------------

- ❑ Five-level comparator mode...Not used

Three-level comparator mode...Not used

Seven-level comparator mode...Send the current level 5 upper limit value.

Command

?	H	3	C _R	L _F
---	---	---	----------------	----------------

Reply

H	3	,	+	0	0	0	5	0	0	C _R	L _F
---	---	---	---	---	---	---	---	---	---	----------------	----------------

- ❑ Five-level comparator mode...Send the current HIHI limit value.

Three-level comparator mode...Send the current HI limit value.

Seven-level comparator mode...Send the current level 4 upper limit value.

Command

?	H	2	C _R	L _F
---	---	---	----------------	----------------

Reply

H	2	,	+	0	0	0	4	0	0	C _R	L _F
---	---	---	---	---	---	---	---	---	---	----------------	----------------

- ❑ Five-level comparator mode...Send the current HI limit value.

Three-level comparator mode...Not used

Seven-level comparator mode...Send the current level 3 upper limit value.

Command

?	H	1	C _R	L _F
---	---	---	----------------	----------------

Reply

H	1	,	+	0	0	0	3	0	0	C _R	L _F
---	---	---	---	---	---	---	---	---	---	----------------	----------------

- ❑ Five-level comparator mode...Send the current LO limit value.

Three-level comparator mode...Not used

Seven-level comparator mode...Send the current level 3 lower limit value.

Command

?	L	1	C _R	L _F
---	---	---	----------------	----------------

Reply

L	1	,	+	0	0	0	2	0	0	C _R	L _F
---	---	---	---	---	---	---	---	---	---	----------------	----------------

- ❑ Five-level comparator mode...Send the current LOLO limit value.

Three-level comparator mode...Send the current LO limit value.

Seven-level comparator mode...Send the current level 2 lower limit value.

Command

?	L	2	C _R	L _F
---	---	---	----------------	----------------

Reply

L	2	,	+	0	0	0	1	0	0	C _R	L _F
---	---	---	---	---	---	---	---	---	---	----------------	----------------

- ❑ Five-level comparator mode...Not used

Three-level comparator mode...Not used

Seven-level comparator mode...Send the current level 1 lower limit value.

Command

?	L	3	C _R	L _F
---	---	---	----------------	----------------

Reply

L	3	,	+	0	0	0	0	0	0	C _R	L _F
---	---	---	---	---	---	---	---	---	---	----------------	----------------

□ Five-level comparator mode...Not used

Three-level comparator mode...Not used

Seven-level comparator mode...Set the level 5 upper limit value.

(No reply for the function setting "5 iF I 0".)

Set the six-digit value excluding the polarity and decimal point.

Command

H	3	,	+	0	0	0	5	0	0	C _R	L _F
---	---	---	---	---	---	---	---	---	---	----------------	----------------

Reply

H	3	,	+	0	0	0	5	0	0	C _R	L _F
---	---	---	---	---	---	---	---	---	---	----------------	----------------

□ Five-level comparator mode...Set the HIHI limit value.

Three-level comparator mode...Set the HI limit value.

Seven-level comparator mode...Set the level 4 upper limit value.

(No reply for the function setting "5 iF I 0".)

Set the six-digit value excluding the polarity and decimal point.

Command

H	2	,	+	0	0	0	4	0	0	C _R	L _F
---	---	---	---	---	---	---	---	---	---	----------------	----------------

Reply

H	2	,	+	0	0	0	4	0	0	C _R	L _F
---	---	---	---	---	---	---	---	---	---	----------------	----------------

□ Five-level comparator mode...Set the HI limit value.

Three-level comparator mode...Not used

Seven-level comparator mode...Set the level 3 upper limit value.

(No reply for the function setting "5 iF I 0".)

Send the six-digit value excluding the polarity and decimal point.

Command

H	1	,	+	0	0	0	3	0	0	C _R	L _F
---	---	---	---	---	---	---	---	---	---	----------------	----------------

Reply

H	1	,	+	0	0	0	3	0	0	C _R	L _F
---	---	---	---	---	---	---	---	---	---	----------------	----------------

□ Five-level comparator mode...Set the LO limit value.

Three-level comparator mode...Not used

Seven-level comparator mode...Set the level 3 lower limit value.

(No reply for the function setting "5 iF I 0".)

Send the six-digit value excluding the polarity and decimal point.

Command

L	1	,	+	0	0	0	2	0	0	C _R	L _F
---	---	---	---	---	---	---	---	---	---	----------------	----------------

Reply

L	1	,	+	0	0	0	2	0	0	C _R	L _F
---	---	---	---	---	---	---	---	---	---	----------------	----------------

□ Five-level comparator mode...Set the LOLO limit value.

Three-level comparator mode...Set the LO limit value.

Seven-level comparator mode...Set the level 2 lower limit value.

(No reply for the function setting "S iF I 0".)

Send the six-digit value excluding the polarity and decimal point.

Command

L	2	,	+	0	0	0	1	0	0	C _R	L _F
---	---	---	---	---	---	---	---	---	---	----------------	----------------

Reply

L	2	,	+	0	0	0	1	0	0	C _R	L _F
---	---	---	---	---	---	---	---	---	---	----------------	----------------

❑ Five-level comparator mode...Not used

Three-level comparator mode...Not used

Seven-level comparator mode...Set the level 1 lower limit value.

(No reply for the function setting "S iF I 0".)

Send the six-digit value excluding the polarity and decimal point.

Command

L	3	,	+	0	0	0	0	0	0	C _R	L _F
---	---	---	---	---	---	---	---	---	---	----------------	----------------

Reply

L	3	,	+	0	0	0	0	0	0	C _R	L _F
---	---	---	---	---	---	---	---	---	---	----------------	----------------

Replies to the commands other than examples above when the function setting "S iF I" is selected.

❑ The scale is not in a state where a command could be executed. Then, the scale will reply "I".

Command

Z	C _R	L _F
---	----------------	----------------

Reply

I	C _R	L _F
---	----------------	----------------

 The scale is not in a condition that zero operation is possible.

❑ Command does not exist for the HV/HW-C/CP series. Then, the scale will reply "?".

Command

B	C _R	L _F
---	----------------	----------------

Reply

?	C _R	L _F
---	----------------	----------------

 The scale received an undefined command.

❑ When the function setting "S iF I 0" is selected, undefined commands are ignored and no reply is sent.



15.6. Using UFC (Universal Flex Coms) Function

- The UFC function allows you to print out as you format the printer (UFC format).
- The scale can store the UFC format as text data. It will include parameters to replace with the count data, weight data and so on.
- The maximum number of text data is 300 characters.
- Using “PF” command, the text data has to be sent to the scale in advance. When the **PRINT** key is pressed or by auto-print mode, the scale will send the stored text data with the parameters replaced by the original data.
- The UFC format data can be sent through one RS-232C or USB interface only. Set one of $\$iF1$ or $\$iF2$ at “2” to send the data. The others must be set at “0” or “1”. When printing using the built-in printer, set $\$iFP$ to “1”.

Store Text Data into the Scale Memory

Command	P	F	,	\$	P	C	,	'	T	E	X	T	'	,	#	2	0	,	\$	S	P	*	2	,	&		
	\$	C	R	,	\$	L	F	,	\$	W	T	,	\$	C	R	,	\$	L	F	C _R	L _F	Terminator					
Reply	P	F	C _R	L _F																							

The “PF” command sends text data that will include:

- Parameters for the scale data and control codes

Parameter	Data & Code
\$PC	Count
\$WT	Weight
\$TR	Tare weight in use
\$TL	Total count
\$AN	Accumulation numbers
\$ID	ID number in use
\$CP	Comparator result

Parameter	Data & Code
\$DT	Date
\$TM	Time
\$CM	Comma
\$SP	Space
\$CR	Carriage Return
\$LF	Line Feed

Use parameters must be used capital letters.

- ASCII text string
Text string is described in single quote marks as ‘Data’.
The single quote itself is written as ’’(2 single quotes).
Example: Text ‘ABC’ is described as ’’ABC’’.
- The ASCII hexadecimal code
The ASCII hexadecimal codes are written in the form “#” + 2 hexadecimal digits.
This will mainly be used to send control codes that can’t be described as a text string.
Example: #04 “EOT” of ASCII code
- Repeat data

The control codes \$SP, \$CR and \$LF can be used with “* + maximum 2 digit number”. That code will be repeated the number of times designated.

Example: \$LF*9 Repeat “\$LF” 9 times.
\$SP*12 Put 12 “Spaces”.

❑ Link mark “&”

If you will send more than 2 lines of data, attach “&” to the end of the first line. Then, the scale considers the data to be continued.

⚠ “Space” or “,” will be used to separate these data. You can skip them, but you cannot skip “,” after “PF”. You must start with “PF,”.

Data Format for the Scale Data

“ ” in examples below shows “Space” (20H).

Parameters for the scale data will be replaced by the format below when the scale sends them out.

⚠ Data has a fixed number of digits including a sign and a decimal point. The insignificant zeros are replaced by “Space (20H)” (except the ID number).

\$PC

				+	1	2	3	4		P	C
--	--	--	--	---	---	---	---	---	--	---	---

 1234 pcs / 9 digit data + 3 digit unit

\$WT

			+	1	2	.	3	4		k	g
--	--	--	---	---	---	---	---	---	--	---	---

 12.34 kg / 9 digit data + 3 digit unit

\$TR

			+	1	2	.	3	4		k	g
--	--	--	---	---	---	---	---	---	--	---	---

 12.34 kg / 9 digit data + 3 digit unit

\$TL

			1	2	3	.	4	0		k	g
--	--	--	---	---	---	---	---	---	--	---	---

 123.40 pcs / 9 digit data + 3 digit unit

\$AN

						1	0
--	--	--	--	--	--	---	---

 10 times / 8 digit data

\$CD

0	0	0	1	2	3
---	---	---	---	---	---

 ID Number 000123 / 6 digit data

\$CP

L	0	2
---	---	---

 Result is “LOLO” / 3 characters, LO2, LO1, HI1, HI2

O	K
---	---

 Result is “OK” / 2 characters

--	--

 Result is not available.

\$DT

2	0	1	7	/	0	3	/	1	8
---	---	---	---	---	---	---	---	---	---

 YYYY / MM / DD

\$TM

1	2	:	3	4	:	5	6
---	---	---	---	---	---	---	---

 12(h) 34(m) 56(s)

Examples of PF command and AD-8127 Printout Sample

AD-8127 Printout
(5 iF 1/5 iF2 = "2")

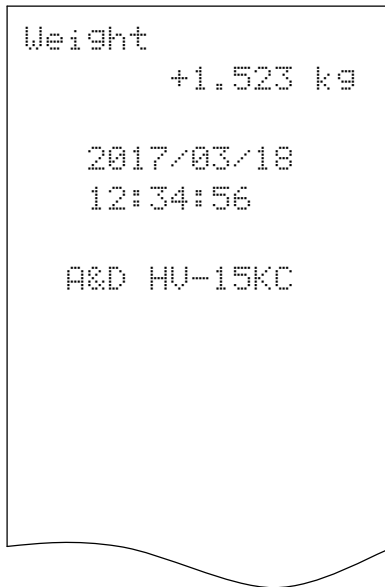

"PF" Command

```
PF, 'Weight', $CR, $LF, &
$SP*4, $WT, $CR, $LF, &
$CR, $LF, &
$SP*3, $DT, $CR, $LF, &
$SP*3, $TM, $CR, $LF, &
$CR, $LF, &
' A&D HV-15KC ', $CR, $LF
```

Terminator codes 

"_" shows "Space".

 Normally the printer needs to receive the terminator, and do not forget to add the terminator code(s) to the end of text data.



16. Specifications

HV-C/CP Series (Weighing capacity of 15 kg to 220 kg)

Models		HV-15KC HV-15KCP			HV-60KC HV-60KCP			HV-200KC HV-200KCP		
Weighing Capacity	[kg]	3	6	15	15	30	60	60	150	220
Min. weighing (1 digit)	[g]	1	2	5	5	10	20	20	50	100
Weighing Capacity	[lb] #	6	15	30	30	60	150	150	300	500
Min. weighing (1 digit)	[lb] #	0.002	0.005	0.01	0.01	0.02	0.05	0.05	0.1	0.2
Weighing Capacity	[oz] #	96	240	480	480	960	2400	2400	4800	8000
Min. weighing (1 digit)	[oz] #	0.05	0.1	0.2	0.2	0.5	1	1	2	5
Weighing Capacity	[lb_oz] #	30 lb			---					
Min. weighing (1 digit)	[lb_oz] #	0.1 oz			---					
Number of samples in counting mode [pieces]		5 (can be changed to 10, 20, 50, 100)								
Max. count number [pieces]		150,000			120,000			110,000		
Display		7 segment fluorescent display, Character height 25 mm, 3 color 5 level comparator LED, Display refreshment rate: 10 times per second								
Repeatability [g]		±1	±2	±5	±5	±10	±20	±20	±50	±100
Linearity [g]		±1	±2	±5	±5	±10	±20	±20	±50	±100
Span drift		20ppm/°C typ. (5°C to 35°C)								
Power source	HV-C	AC adapter Please confirm that the AC adapter type is correct for your local voltage and receptacle type. 50Hz/ 60Hz. Battery TYPE D (R20P/R20PU/LR20) x 4								
	HV-CP	Please confirm that the Main power type is correct for your local voltage and receptacle type.(50Hz/ 60Hz)								
Battery life (HV-C)		Approximately 1200 hours (When using alkaline battery and setting the display to off)								
Ambient temperature and humidity		-10°C to 40°C, Less than 85%R.H. (Do not allow condensation)								
Weighing pan size [mm]		250 x 250			330 x 424			390 x 530		
Dimensions [mm] Width x Depth x Height		255 x 494 x 366			330 x 640 x 750			390 x 746 x 750		
Mass of scale [kg]	HV-C	6			11			17		
	HV-CP	7			12			18		

: If the law in your area permits, you can use these units.

HW-C/CP Series (Weighing capacity of 10 kg to 220 kg)

Models		HW-10KC HW-10KCP	HW-60KC HW-60KCP	HW-100KC HW-100KCP	HW-200KC HW-200KCP
Weighing Capacity	[kg]	10	60	100	220
Min. weighing (1 digit)	[g]	1	5	10	20
Weighing Capacity	[lb] #	20	150	200	500
Min. weighing (1 digit)	[lb] #	0.002	0.01	0.02	0.05
Weighing Capacity	[oz] #	320	2400	3200	8000
Min. weighing (1 digit)	[oz] #	0.05	0.2	0.5	1
Weighing Capacity	[lb_oz] #	20 lb	---		
Min. weighing (1 digit)	[lb_oz] #	0.1 oz			
Number of samples in counting mode [pieces]		5 (can be changed to 10, 20, 50, 100)			
Max. count number [pieces]		100,000	120,000	100,000	110,000
Display		7 segment fluorescent display, Character height 25 mm, 3 color 5 level comparator LED, Display refreshment rate: 10 times per second			
Repeatability [g]		±2	±10	±20	±40
Linearity [g]		±2	±10	±20	±40
Span drift		20ppm/°C typ. (5°C to 35°C)			
Power source	HW-C	AC adapter Battery x 6 pieces	Please confirm that the AC adapter type is correct for your local voltage and receptacle type. 50Hz/ 60Hz. TYPE D (R20P/R20PU/LR20) x 4		
	HW-CP	Please confirm that the Main power type is correct for your local voltage and receptacle type.(50Hz/ 60Hz)			
Battery life (HW-C)		Approximately 1200 hours (When using alkaline battery and setting the display to off)			
Ambient temperature and humidity		-10°C to 40°C, Less than 85%R.H. (Do not allow condensation)			
Weighing pan size [mm]		250 x 250	330 x 424	390 x 530	390 x 530
Dimensions [mm] Width x Depth x Height		255 x 494 x 366	330 x 640 x 750	390 x 746 x 750	390 x 746 x 750
Mass of scale [kg]	HW-C	6	11	17	17
	HW-CP	7	12	18	18

: If the law in your area permits, you can use these units.

Dimensions

Models

HV-15KC HV-15KCP
 HW-10KC HW-10KCP

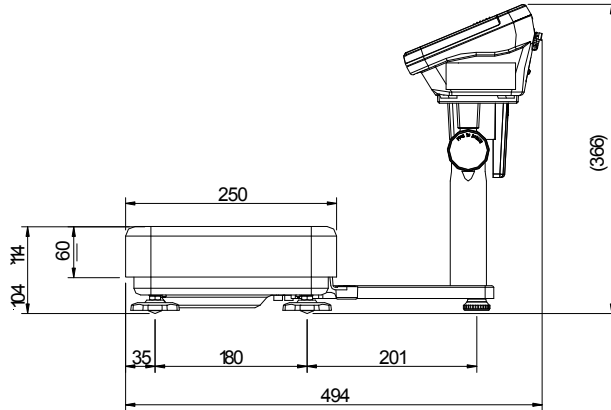
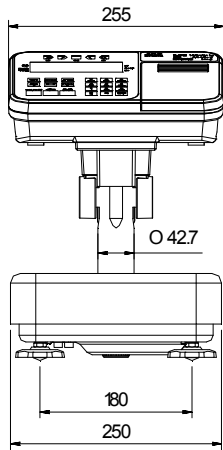
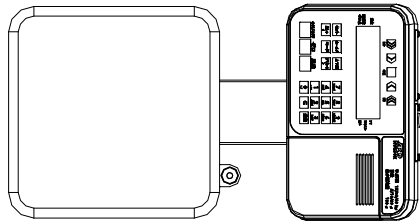

Models

HV-60KC HV-60KCP
 HW-60KC HW-60KCP

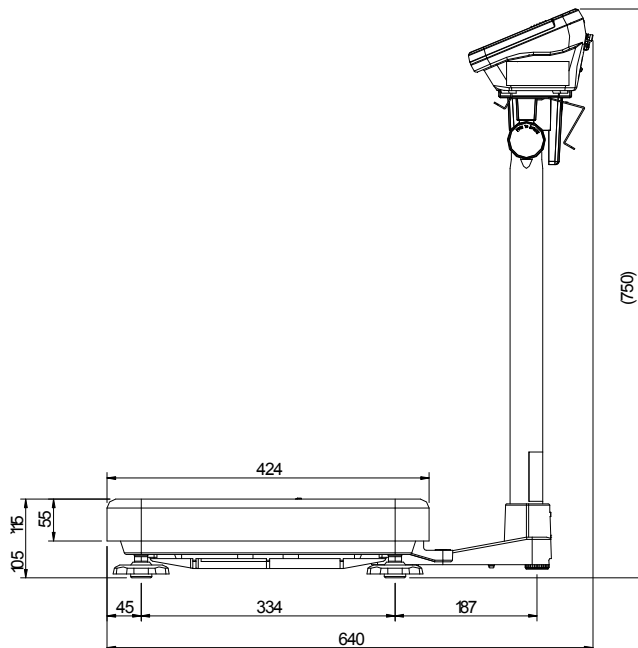
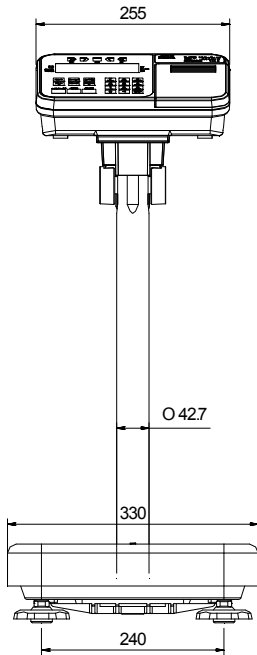
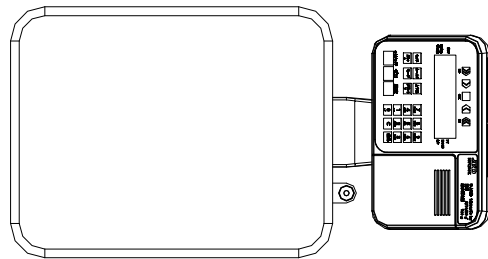

Unit: mm

Models

- HV-200KC HV-200KCP
- HW-100KC HW-100KCP
- HW-200KC HW-200KCP

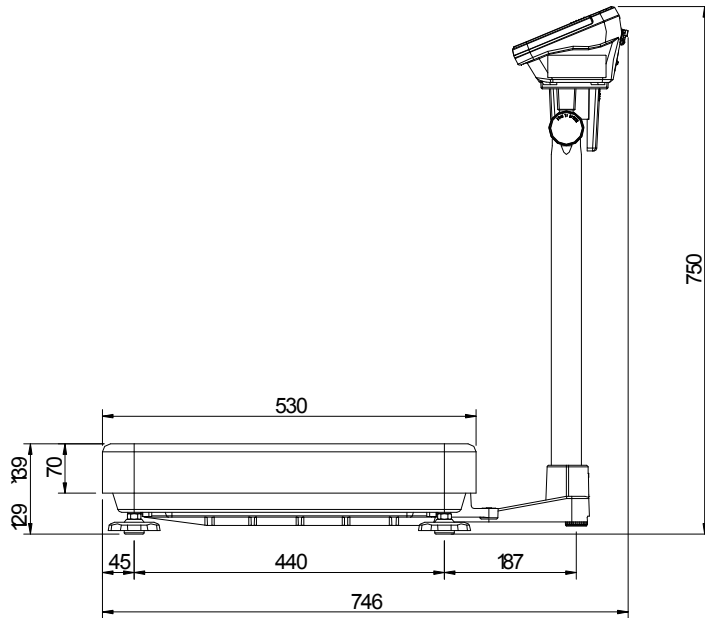
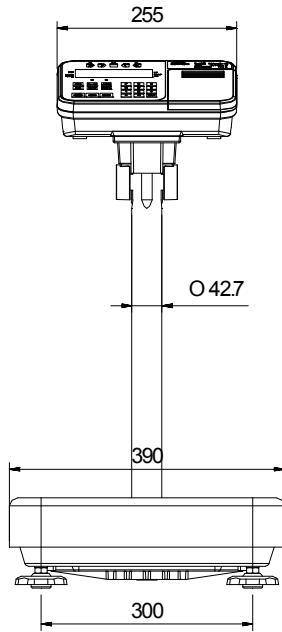
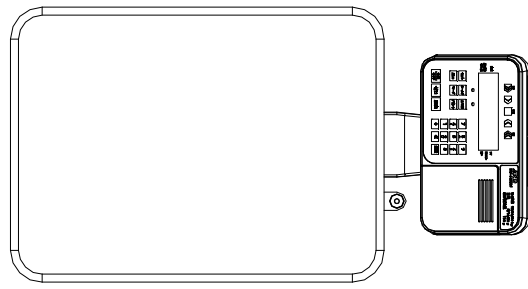

Unit: mm



17. Maintenance

- Refer to "3. Precautions" for use.
- Refer to "6.1. Display and Symbols " for displayed error code.
- Refer to "13. Calibration (Adjusting the Scale)" for precision weighing.
- Periodically check the accuracy of the weighing. Calibrate the scale, if it has been moved to another location or the environment has changed.



17.1. Check Points Before Calling Maintenance Service

In this situation	Confirm these items
Nothing is displayed. Scale does not turn on.	<ul style="list-style-type: none"> □ Is the AC adapter properly connected? □ Is the AC adapter of the correct voltage ? □ Are the batteries dead ? □ Is the battery direction correct ?
The scale does not display zero upon power-on.	<ul style="list-style-type: none"> □ Check around the weighing pan. □ Is there anything on the pan? □ Perform zero point calibration.
----- is displayed and does not proceed.	<ul style="list-style-type: none"> □ The weight value is unstable due to drift, vibration or other. A breeze or vibration may be affecting the measurement. Check around the weighing pan. □ Check the connection of load cell cable. □ No zero display when the display is turned on. Remove anything that is on the pan. □ Perform zero point calibration.
CAL E is displayed	<ul style="list-style-type: none"> □ Calibration error that means "Too heavy".
-CAL E is displayed	<ul style="list-style-type: none"> □ Calibration error that means "Too light".
E is displayed	<ul style="list-style-type: none"> □ Weighing error that means "Overload".
-E is displayed	<ul style="list-style-type: none"> □ Weighing error that means "Underload".
Fixed display	<ul style="list-style-type: none"> □ Do you use the hold function? □ Turn off the scale and turn it on.

17.1.1. Repair

Do not disassemble or assemble the scale without an authorized service engineer. It may cause an electrical shock or damage to the scale. In this case, repair is not covered under warranty. Contact your local A&D dealer if your scale needs service or repair.

AND