

COMPACT BENCH SCALES

SJ-WP and SJ-WP-BT Series

IP67 Washdown Rated



High resolution and legal-for-trade
High resolution with  **Bluetooth™**

AND
A&D Weighing

Compact Washdown Bench Scales

IP Rated & Meets NSF Standards for Hygiene

The SJ-WP/ -BT is NSF listed for 169 and the new 14159 standard for direct contact with meat. Ideal for weighing in wet and harsh places, just soak and wash the entire scale right in the sink for a complete clean.

Take advantage of this innovative design to make sure your food processing lines stay clean. For food portioning applications, weigh directly on the pan, eliminating the tare-scale step.



Reduce Waste and Increase Productivity

BRIGHT, TRAFFIC-STYLE 5-STEP COMPARATOR LIGHTS



Fresh produce relies and manual weighing to pack punnets and clam shells, ready for supermarket consumers.

Operators respond to lights much faster than to a numeric display, increasing productivity and reducing over-fill. Store up to 10 settings for fast changes of pack sizes.

TAKE-AWAY CHECK WEIGHING



Tare the initial weight (either manual or automatic).

Take out the content to reach target weight.

The scale performs tare automatically and returns the display to zero.

Delivering Real Convenience

Features and Functions



User-selectable and trade-legal class III (SJ-WP)



Meets NSF 169 and 14159 standards

Stainless steel pan, easily removed for cleaning. Or just wash the entire scale in the sink with its IP67 waterproof rating



Battery life indicator. 5000 hours on 6 alkaline batteries

Fast measurements, stable within 1/2 second

NET and ZERO indicators for true weighing

Keylock for supervisor control of settings

Automatic Power-off function standard to prolong battery life

Accurate counting function standard

Tare up to full capacity

Print or send data to external display or PC via Bluetooth (SJ-WP-BT models)

g, kg, lbs and more units of measure

Unique sealed weighing element is separated from the electronics, making the SJ-WP more rugged than traditional scales

Bright, backlit display with 1" high numbers. Easily viewable, even in low lighting conditions

Traffic light comparator with 3 or 5 stages for fast check-weighing

4 adjustable feet in a solid ABS base

Simplify Data Collection with Bluetooth



SJ-WP BT Series

For the SJ-WP-BT models, add Bluetooth connectivity with the AD-8541-PC. Send commands from a PC and receive data from the scale. Save time when setting or changing the comparator limits with this handy add-on. Range approx. 10 m.



SJ-WP BT Series

AD-8931

The AD-8931 receives and displays weighing values from the SJ-WP-BT. Stands on a table or wall-mount, it's your choice. Range approx. 10 m.

Specifications

		SJ-3000WP SJ-3000WP-BT	SJ-6000WP SJ-6000WP-BT	SJ-15KWP SJ-15KWP-BT	SJ-30KWP SJ-30KWP-BT
kg	Capacity	3	6	15	30
	Min. display	0.0001	0.0002	0.0005	0.001
		0.0002	0.0005	0.001	0.002
		0.0005 ¹	0.001 ¹	0.002 ¹	0.005 ¹
	0.001 ²	0.002 ²	0.005 ²	0.01 ²	
lb	Capacity	6.6	13	33	66
	Min. display	0.0002	0.0005	0.001	0.002
		0.0005	0.001	0.002	0.005
		0.001 ¹	0.002 ¹	0.005 ¹	0.01 ¹
	0.002 ²	0.005 ²	0.01 ²	0.02 ²	
oz	Capacity	105	210	520	1050
	Min. display	0.005	0.01	0.02	0.05
		0.01	0.02	0.05	0.1
		0.02 ¹	0.05 ¹	0.1 ¹	0.2 ¹
	0.05 ²	0.1 ²	0.2 ²	0.5 ²	
lb-oz ³	Capacity	6	13	33	66
	Min. display	0.1			
Weighing Units ²		g, kg, lb, oz, ozt, lb-oz, tl (tael), t (tola), pcs (counting), N			
Counting mode	Number of samples	5, 10, 20, 50 or 100			
	Max. countable number	120,000			
Repeatability (std. deviation)		0.5 g	1 g	2 g	5 g
Linearity		±1 g	±2 g	±5 g	±10 g
Sensitivity drift (typical)		±50 ppm / °C (5 °C to 35 °C / 41 °F to 95 °F)			
Display	Weight Display	7 segment LCD (character height: 26 mm) with white LED backlight; 20 times / second			
	Comparator Lights	Tricolor 5-step LED: red / yellow / green / yellow / red			
Display refresh rate		20 times / second			
Operating temperature		-10 °C to 40 °C / 14 °F to 104 °F			
Battery Life (with LED and backlight OFF)		Approx. 5,000 hours with 6 D alkaline batteries Approx. 2,000 hours with 6 D manganese batteries			
Weighing Pan size		232 (W) × 192 (D) mm / 9.13 (W) × 7.56 (D) in			
Dimensions (W × D × H)		236 (W) × 260 (D) × 148 (H) mm / 9.3 (W) × 10.2 (D) × 5.8 (H) See manual for drawings.			
Weight (approx.)		Approx. 4 kg / 9 lb			
Standard accessories		Instruction manual, screwdriver, cleaning pick (one sheet)			

1. SJ-WP ships in this enhanced resolution mode, follow instructions to put into trade-legal mode or to increase readability to maximum.

2. Legal for trade Class III readability. Available UoM: g, kg, oz only. Measurement Canada AM-6118; NTEP CC: 18-131

3. lb-oz only available in high resolution mode, non trade-legal

Note: The SJ-WP are dual-mode high-resolution and trade-legal. The SJ-WP-BT is high resolution only, not LFT.

Accessories

AD-8541-PC

Supported OS	Windows XP/Vista/7/8.1/10, 32/64 bit
Range	Max 10 meters, line-of-sight

AD-8931

Display	7-segment backlit LCD, 1" character height. Same unit of measure as on SJ-WP-BT
Range	Max. 10 meters, line-of-sight
Power	4 x AAA batteries. Approx. 200 hours backlight off, 100 hours on
Size	160 x 74 x 25 mm (W x D x H), approx. 160 without batteries

Dimension

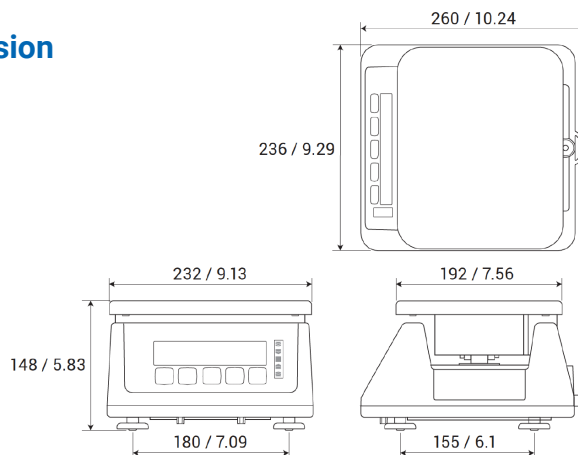

Key Features



Compliance



NSF listed for 169 and 14159, all models.
Bluetooth 4.2 (BLE) (SJ-WP-BT)
NTEP CC:18-131.
Measurement Canada AM-6118