

INSTRUCTION MANUAL



GREENLEE®

A Textron Company

CM-660

CM-860

CM-960

CMH-600

CMI-600

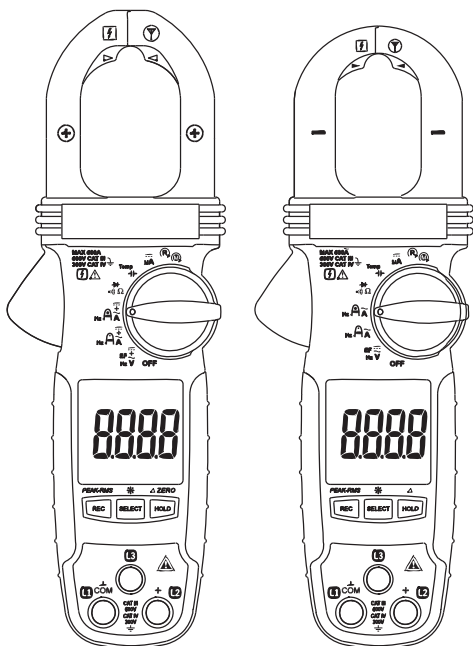

Clamp Meters

**Test Equipment
Depot**



1-800-517-8431

99 Washington Street
Melrose, MA 02176
Phone 781-665-1400
Toll Free 1-800-517-8431



Visit us at www.TestEquipmentDepot.com

Description

The Greenlee CM-660, CM-860, CM-960, CMH-600, and CMI-600 Clamp Meters are hand-held testing devices with the following measurement capabilities: AC and DC voltage, AC current, AC current AmpTip™, frequency, non-contact electric field (EF) detection, and resistance. They also check diodes and verify continuity. These meters are designed to be placed on or removed from insulated or uninsulated conductors.

Additional functionality specific to each model includes:

Function	CMI-600	CM-960	CMH-600	CM-860
AC + DC Voltage	•	•		
DC Current AmpTip™	•	•		
DC + AC Current AmpTip™	•	•		
DC Current	•	•		
µDC Current	•		•	
Temperature (K-style thermocouple)	•		•	
Motor Rotation	•		•	
Phase Rotation	•		•	
Peak RMS Capture	•	•	•	
Capacitance	•	•	•	•
Backlight	•	•	•	•
Zero Mode	•	•	•	•

Other capabilities include:

- Hold Mode to capture the present LCD value
- Record Minimum, Maximum, or Average Mode
- Intelligent Auto Power Off
- Automatic ranging

Safety

Safety is essential in the use and maintenance of Greenlee tools and equipment. This instruction manual and any markings on the tool provide information for avoiding hazards and unsafe practices related to the use of this tool. Observe all of the safety information provided.

Purpose of This Manual

This instruction manual is intended to familiarize all personnel with the safe operation and maintenance procedures for the Greenlee CM-660, CM-860, CM-960, CMH-600, and CMI-600 Clamp Meters.

Keep this manual available to all personnel. Replacement manuals are available upon request at no charge at www.greenlee.com.

Important Safety Information



SAFETY ALERT SYMBOL

This symbol is used to call your attention to hazards or unsafe practices which could result in an injury or property damage. The signal word, defined below, indicates the severity of the hazard. The message after the signal word provides information for preventing or avoiding the hazard.

⚠ DANGER

Immediate hazards which, if not avoided, **WILL** result in severe injury or death.

⚠ WARNING

Hazards which, if not avoided, **COULD** result in severe injury or death.

⚠ CAUTION

Hazards or unsafe practices which, if not avoided, **MAY** result in injury or property damage.



⚠ WARNING

Read and understand this material before operating or servicing this equipment. Failure to understand how to safely operate this tool could result in an accident causing serious injury or death.



⚠ WARNING

Electric shock hazard:
Contact with live circuits could result in severe injury or death.



Do not discard this product or throw away!

For recycling information, go to www.greenlee.com.

All specifications are nominal and may change as design improvements occur. Greenlee Textron Inc. shall not be liable for damages resulting from misapplication or misuse of its products.

© Registered: The color green for electrical test instruments is a registered trademark of Textron Innovations Inc.

AmpTip is a trademark of BTC.

KEEP THIS MANUAL

Important Safety Information

WARNING

Electric shock and fire hazard:

- Do not expose this unit to rain or moisture.
- Do not use the unit if it is wet or damaged.
- Clamp meter, test leads or any other clamp accessory, when used to make a measurement, create a System. The System is rated for CAT III 600 V or CAT IV 300 V when using the test leads or accessories provided with the meter. The System CAT and voltage rating is limited by the lowest rated component in the System when using test leads or accessories not provided with the meter.
- Inspect the test leads or accessory before use. They must be clean and dry, and the insulation must be in good condition. Do not use the test lead if the contrasting inner layer of insulation is visible.
- Use this unit for the manufacturer's intended purpose only, as described in this manual. Any other use can impair the protection provided by the unit.

Failure to observe these warnings could result in severe injury or death.

WARNING

Electric shock hazard:

- Do not apply more than the rated voltage between any two input terminals, or between any input terminal and earth ground.
- Keep hands and fingers below the barriers on the test leads and the clamp meter body.

Failure to observe these warnings could result in severe injury or death.

WARNING

Electric shock hazard:

- Do not operate with the case open.
- Before opening the case, remove the test leads from the circuit and shut off the unit.

Failure to observe these warnings could result in severe injury or death.

Important Safety Information

⚠ WARNING

Electric shock hazard:

- Unless measuring voltage, current, or frequency, shut off and lock out power. Make sure that all capacitors are discharged. Voltage must not be present.
- Set the selector and connect the test leads so that they correspond to the intended measurement. Incorrect settings or connections can result in incorrect measurements or damage to the unit.
- Using this unit near equipment that generates electromagnetic interference can result in unstable or inaccurate readings.

Failure to observe these warnings could result in severe injury or death.

⚠ CAUTION

Electric shock hazard:

- Do not change the measurement function while the test leads are connected to a component or circuit.
- Do not clamp the jaw around a conductor carrying a frequency greater than 400 Hz. The magnetic circuitry may reach a hazardous temperature if this frequency is exceeded.

Failure to observe these precautions may result in injury and can damage the unit.

⚠ CAUTION

Electric shock hazard:

- Do not attempt to repair this unit. It contains no user-serviceable parts.
- Do not expose the unit to extremes in temperature or high humidity. Refer to "Specifications."

Failure to observe these precautions may result in injury and can damage the unit.

Identification

1. Antenna for non-contact EF detection
2. Jaw center indicator for best current accuracy; polarity indicator for DC amps
3. Selects a function or turns power off
4. LCD
5. Input jack for phase and motor rotation functions only
6. Positive input terminal; L2 input for motor and phase rotation
7. Negative, common, or ground input terminal; L1 input for motor and phase rotation
8. Refer to explanation under “Using the Features.”
9. Jaw lever
10. Keep hand or fingers below the dashed line during operation.
11. Jaw
12. Center indicator for AmpTip™ function

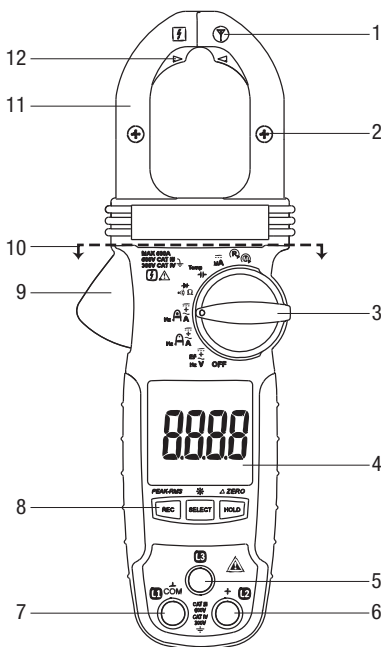

Symbols on the Unit

- Warning—Read the instruction manual
- Warning—Risk of electric shock
- Earth ground
- Double insulation
- AC (alternating current)
- DC (direct current)
- Application around or removal from hazardous live conductors is permitted.

Display Icons

1. **AUTO** Automatic ranging is enabled.
2. **R** Record function is enabled.
3. **→+** Diode
4. **•))** Continuity
5. **P-RMS** PEAK-RMS mode is enabled.
6. **(R)** Phase rotation main supply
7. **(M)** Motor rotation
8. **8.8.8.8** Numeric display
9. **μ** Micro (10⁻⁶)
10. **F** Farad
11. **A** Ampere
12. **V** Volt
13. **Hz** Hertz (frequency in cycles per second)
14. **Ω** Ohm
15. **k** Kilo (10³)
16. **A** AmpTip™ function is enabled.
17. **Δ** Relative zero function is enabled.
18. **-** Polarity indicator
19. **VFD** AC measurement with filter for accuracy on variable frequency drives
20. **~** AC measurement is selected.
21. **+** AC + DC measurement is selected.
22. **---** DC measurement is selected.
23. **+** Low battery
24. **H** Hold function is selected.
25. **MAX** Maximum value being displayed
26. **MIN** Minimum value being displayed
27. **AVG** Average value being displayed

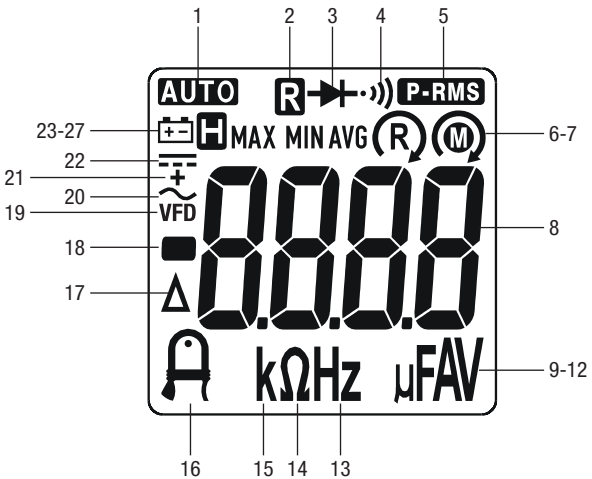

Using the Features

All Models

- **REC:** Press momentarily to activate MAX/MIN/AVG recording mode. **G** and “MAX MIN AVG” appear on the display. The meter beeps when new maximum or minimum reading is updated. The average reading is calculated over time. Press the button momentarily to read the MAX, MIN and AVG readings in sequence. Press the button for 1 second to exit MAX/MIN/AVG recording mode. APO is disabled automatically in this mode.
- **SELECT:** Press momentarily to toggle between functions, measurement modes, or display modes. The last used setting becomes the default when that function is selected again. To change the default, select a new setting. The setting will be stored in nonvolatile memory.
- **HOLD:** Press momentarily to hold the present value on the display. Press again to exit this mode.
- **Intelligent Auto Power Off (APO):** The meter automatically turns off after approximately 32 minutes of inactivity to extend battery life. Active meter function is specified as: selector switch is rotated or pushbuttons are pressed; readings above 8.5% of the range; non-OL readings for resistance, continuity, or diode function; non-zero readings for Hz function; phase rotation segment moving. To wake up the meter from Auto Power Off, press the **SELECT** button momentarily and release or turn the rotary switch **OFF** and then back on. Always turn the rotary switch to the **OFF** position when the meter is not in use.

CM-860, CM-960, CMH-600, and CMI-600 Only





- : Press the **SELECT** button for 1 second to toggle the LCD backlight. The backlight automatically turns off after 32 seconds to extend battery life.
- **Δ:** Press the **Δ** button for 1 second to toggle between zero and normal mode. In zero mode the value on the LCD when the button is pressed becomes the offset. As the input value changes, the offset is subtracted from the actual value. This modified value is shown on the LCD.

Note: Δ operation when DCA or DC + ACA functions are selected offsets any magnetic hysteresis in the jaw. If DCA or DC + ACA reading before measuring is not zero, press the Δ button for 1 second. The LCD will display “dc_0”. When this clears, the meter is ready for operation. When measuring more than 5 A, this mode is disabled. As an indication, the meter will beep three times.

CM-960, CMH-600, and CMI-600 Only

- **PEAK-RMS:** Press the **PEAK-RMS** button for 1 second to activate PEAK-RMS mode to capture peak current or voltage in duration as short as 80 ms. **P-RMS** appears on the display. Press the button for 1 second to exit PEAK-RMS mode. APO is disabled automatically in this mode.

CMH-600 and CMI-600 Only

-  and : If desired, press and hold the **REC** button while turning the meter ON to enable the Beeper feature. If the segments indicate a clockwise movement, the beeper sounds a single long beep per segment cycle. If the segments indicate a counterclockwise movement, the beeper sounds three short beeps per segment cycle.
 - : Ensure the motor is electrically isolated from its power source. Press the **SELECT** button momentarily to select Motor function. Connect the meter to the motor as described in the “Settings Table” section of this manual. From the perspective of looking down the shaft of the motor, spin it clockwise. If the meter indicates a clockwise movement, the motor leads connected to L1, L2, and L3 of the meter are T1, T2, and T3, respectively. If the meter indicates a counterclockwise movement, swap any two connects between the meter and motor. Then retest.
 - : Press the **SELECT** button momentarily to select Phase function. Connect the meter to the phases as described in the “Settings Table” section of this manual. If the meter indicates a clockwise movement, the phases connected to L1, L2, and L3 of the meter are L1, L2, and L3, respectively. If the meter indicates a counterclockwise movement, swap any two connects between the meter and phases. Then retest.

Using the Test Leads

⚠ WARNING

Electric shock hazard:

The test leads supplied with this product comply with safety standards that limit the exposed length of the probe tip to 4 mm for measurement categories III and IV. These test leads include a cap that must be in place when used in measurement category III or IV applications.

Failure to observe this warning could result in severe injury or death.



Cap must be in place for measurement category III or IV applications.

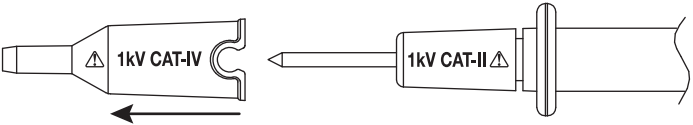

Cap can be removed for measurement category I or II applications.

AC Measurement



AC measurements are usually displayed as RMS (root mean square) values. The RMS value is equal to the value of a DC waveform, which would deliver the same power if it replaced the time-varying waveform. Two AC measurement methods are average-responding RMS calibrated and true RMS-reading.

The average-responding RMS calibrated method takes the average value of the input signal after full wave rectification, multiplies it by 1.11, and displays the result. This method is accurate if the input signal is a pure sine wave.

The true RMS-reading method uses internal circuitry to read the true RMS value. This method is accurate, within the specified crest factor limitations, whether the input signal is a pure sine wave, square wave, triangle wave, half wave, or signal with harmonics. The ability to read true RMS provides much more measurement versatility. The Greenlee CM-660, CM-860, CM-960, CMH-600, and CMI-600 are true RMS meters.

The Waveforms and Crest Factors table shows some typical AC signals and their RMS values.

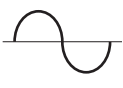
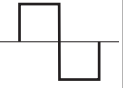
Waveforms and Crest Factors

Waveform				
RMS Value	100	100	100	100
Average Value	90	100	87	64
Crest Factor* (ξ)	1.414	1	1.73	2

* The crest factor is the ratio of the peak value to the RMS value; it is represented by the Greek letter ξ.

AC + DC True RMS

AC + DC true RMS calculates both of the AC and DC components given by the expression

$$\sqrt{(AC\ rms)^2 + DC^2}$$

when making measurements and responds accurately to the total effective RMS value regardless of the waveform. Distorted waveforms with the presence of DC components and harmonics may cause:

- Transformers, generators, and motors to overheat
- Circuit breakers to trip prematurely
- Fuses to blow
- Neutrals to overheat due to the triplen harmonics present on the neutral
- Bus bars and electrical panels to vibrate

CM-960 and CMI-600 can be set to display AC true RMS or AC + DC true RMS.

AC Bandwidth

AC bandwidth is the range of frequencies over which AC measurements can be made within the specified accuracy. It is the frequency response of the AC functions—not of the frequency measurement functions. A meter cannot accurately measure the AC value with frequency spectrums outside its bandwidth. Complex waveforms, noise, and distorted waveforms contain frequency components that are much higher than the fundamental; for example, high frequency noise on a 50/60 Hz power line.

Operation

	⚠ WARNING
	<p>Electric shock hazard: Contact with live circuits could result in severe injury or death.</p>

Operating Procedure

1. Refer to the “Settings Table.” Set the selector to the proper setting, press **SELECT** (when instructed to do so), and connect the test leads to the meter.
2. Refer to “Typical Measurements” for specific measurement instructions.
3. Test the unit on a known functioning circuit or component.
 - If the unit does not function as expected on a known functioning circuit, replace the batteries.
 - If the unit still does not function as expected, call Greenlee for technical assistance at 800-435-0786.
4. Take the reading from the circuit or component to be tested.

Operation (cont'd)

Settings Table

To measure this value ...	Set the selector to this symbol ...	These icons appear on the display ...	Connect the red lead to ...	Connect the black lead to ...
ALL MODELS				
Voltage (AC)			+	COM
Voltage (DC)			+	COM
Current, AmpTip™ (AC)			N/A	N/A
Current (AC)			N/A	N/A
Continuity			+	COM
Resistance			+	COM
Diode			+	COM
Frequency	Hz	Hz	+	COM
Electric Field (EF)*	EF	EF	N/A	COM
CM-860, CM-960, CMH-600, and CMI-600 Only				
Capacitance**			+	COM
CM-960 and CMI-600 Only				
Voltage (AC + DC)			+	COM
Current, AmpTip™ (DC)			N/A	N/A
Current, AmpTip™ (AC + DC)			N/A	N/A
Current (DC)			N/A	N/A
Current (AC + DC)			N/A	N/A
CMH-600 and CMI-600 Only				
Temperature	Temp	C or F	***	
Current (μDC)			+	COM
Phase Rotation†			+	COM
Motor Rotation†			+	COM

* Use the top side of the stationary jaw, or for more precise measurements use a probe in the COM terminal.

** Discharge capacitor before measurement. Refer to "Typical Measurements" regarding polarized capacitors.

*** Thermocouple + connects to +, thermocouple – connects to COM.

† Yellow lead connects to L3.

Typical Measurements and Accuracy

Refer to the “Specifications” section for operating conditions and temperature coefficient.

Accuracy is specified as follows: \pm (a percentage of the reading + a fixed amount) at 23 °C \pm 5 °C (73.4 °F \pm 9 °F).

Frequency must be within the specified bandwidth for non-sinusoidal waveforms. Crest factors, unless otherwise specified, are as follows:

- Crest factor < 2.5:1 at full scale
- Crest factor < 5.0:1 at half scale

Frequency

Function	Sensitivity (Sine RMS)*	Range
600 V	50 V	5.00 Hz ~ 999.9 Hz
60.0 A AmpTip™	40 A	50.00 Hz ~ 400.0 Hz
60.00 A, 600.0 A	40 A	50.00 Hz ~ 400.0 Hz

* DC bias must be less than 50% of the Sine RMS value.

Accuracy of Frequency Range

Display Range	Accuracy
xx.xx	\pm (1.0% + 0.05 Hz)
xxx.x	\pm (1.0% + 0.5 Hz)

Voltage Measurement

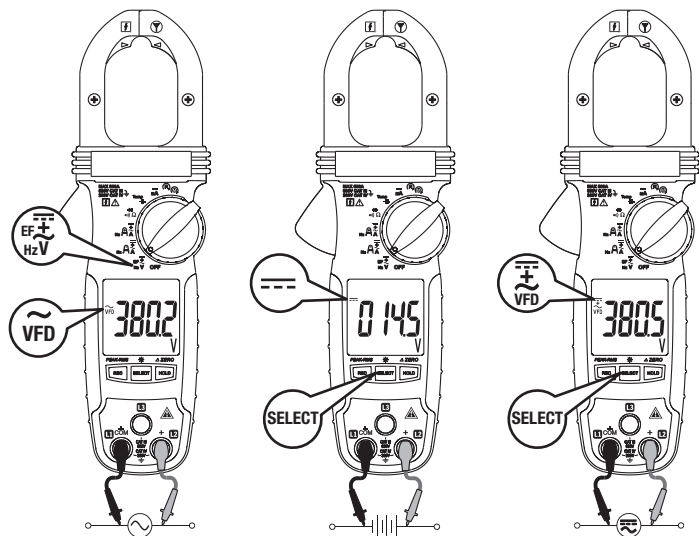

AC Voltage

Range	Accuracy at 50 Hz to 60 Hz
600.0	\pm (1.0% + 0.5 V)

DC Voltage

Range	Accuracy
600.0	\pm (1.0% + 0.5 V)

AC + DC Voltage (CM-960, CMI-600 only)

Range	Accuracy at DC, 50 Hz to 60 Hz
600.0	\pm (1.2% + 0.7 V)

Input Impedance: 10 M Ω , 100 pF nominal

Typical Measurements and Accuracy (cont'd)

Current Measurement

μA DC Current

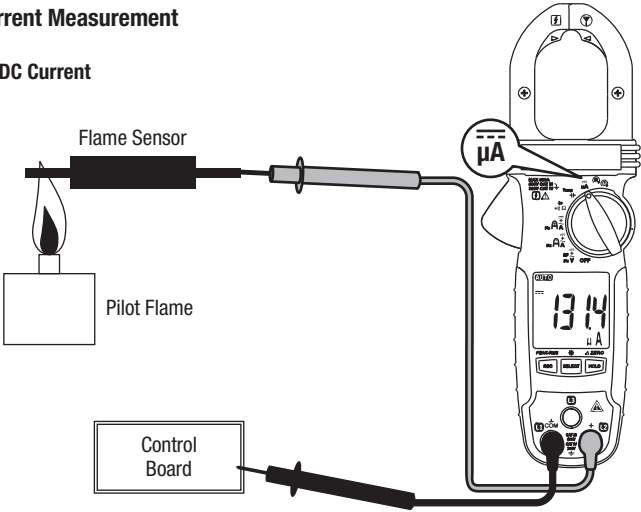

μDC Current (CMH-600 and CMI-600 only)

Range	Accuracy	Burden Voltage
200.0 μA	± (1.0% + 0.5 μA)	3.5 mV/μA
2000 μA	± (1.0% + 5 μA)	

AmpTip™ Function

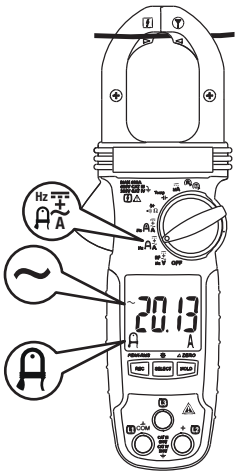

AmpTip™ AC Current

Range	Accuracy Range	Accuracy at 50 Hz to 60 Hz**
60.00 A	< 0.20 A*	unspecified
	0.00 A to 3.99 A	± (1.5% + 0.15 A)
	4.00 A to 60.00 A	± (1.5% + 0.05 A)

* For CM-660, CM-860, and CMH-600 only.

** For CM-960 and CMI-600 only, induced error for adjacent current carrying conductors is < 0.01 A/A.

AmpTip™ DC Current (CM-960 and CMI-600 only)

Range	Accuracy Range	Accuracy†
60.00 A	0.00 A to 3.99 A	± (2.0% + 0.15 A)
	4.00 A to 60.00 A	± (2.0% + 0.05 A)

AmpTip™ DC + AC Current (CM-960 and CMI-600 only)

Range	Accuracy Range	Accuracy at DC, 50 Hz to 60 Hz†
60.00 A	0.00 A to 3.99 A	± (2.0% + 0.17 A)
	4.00 A to 60.00 A	± (2.0% + 0.07 A)

† Induced error for adjacent current carrying conductors is < 0.01 A/A.

Note: Use Δ if there is an offset before the measurement is taken.

Typical Measurements and Accuracy (cont'd)

Current Measurement

(cont'd)

AC and DC Clamp

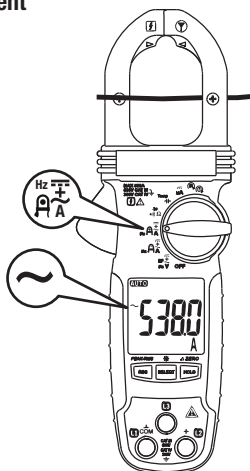

AC Current (CM-960 and CMI-600 only)

Range	Accuracy Range	Accuracy at 50 Hz to 100 Hz*†	Accuracy at 100 Hz to 400 Hz*†
60.00 A	0.00 A to 8.99 A	± (1.8% + 0.15 A)	± (2.0% + 0.15 A)
	9.00 A to 60.00 A	± (1.8% + 0.05 A)	± (2.0% + 0.05 A)
600.0 A	60.0 A to 600.0 A	± (1.8% + 0.5 A)	± (2.0% + 0.5 A)

* Maximum crest factor < 2:1 at full scale and < 4:1 at half scale.

AC Current (CM-660, CM-860, and CMH-600 only)

Range	Accuracy Range	Accuracy at 50 Hz to 100 Hz*†	Accuracy at 100 Hz to 400 Hz*†
60.00 A	0.00 A to 0.19 A	unspecified	unspecified
	0.20 A to 5.99 A	± (1.8% + 0.15 A)	± (2.0% + 0.15 A)
	6.00 A to 60.00 A	± (1.8% + 0.05 A)	± (2.0% + 0.05 A)
600.0 A	60.0 A to 600.0 A	± (1.8% + 0.5 A)	± (2.0% + 0.5 A)

* For any measurement, when the conductor is not positioned on the center of the jaws, add 2.0% to the accuracy for position error.

DC Current (CM-960 and CMI-600 only)

Range	Accuracy Range	Accuracy†
60.00 A	0.00 A to 8.99 A	± (2.0% + 0.15 A)
	9.00 A to 60.00 A	± (2.0% + 0.05 A)
600.0 A	60.0 A to 600.0 A	± (2.0% + 0.5 A)

AC + DC Current (CM-960 and CMI-600 only)

Range	Accuracy Range	Accuracy at 50 Hz to 100 Hz†	Accuracy at 100 Hz to 400 Hz†
60.00 A	0.00 A to 8.99 A	± (2.2% + 0.15 A)	± (2.7% + 0.17 A)
	9.00 A to 60.00 A	± (2.2% + 0.05 A)	± (2.7% + 0.07 A)
600.0 A	60.0 A to 600.0 A	± (2.2% + 0.5 A)	± (2.7% + 0.7 A)

† Induced error for adjacent current carrying conductors is < 0.01 A/A.

Note: Use Δ if there is an offset before the measurement is taken.

Typical Measurements and Accuracy (cont'd)

Resistance Measurement

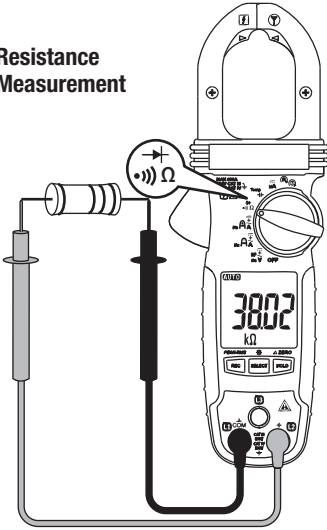

Resistance

Range	Accuracy
600.0 Ω	± (1.0% + 0.5 Ω)
6.000 kΩ	± (1.0% + 0.005 kΩ)
60.00 kΩ	± (1.0% + 0.05 kΩ)

Open Circuit Voltage: 1.0 VDC

Continuity Check

Continuity

Tone Threshold: Between 10 Ω and 250 Ω

Response Time: Approximately 32 ms

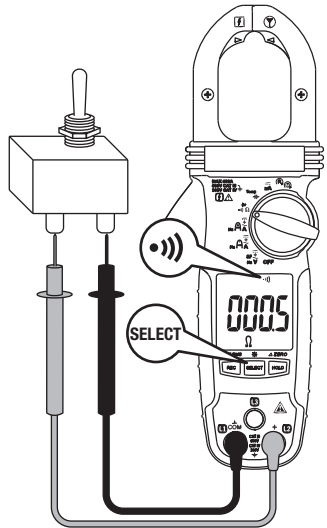

Capacitance Measurement

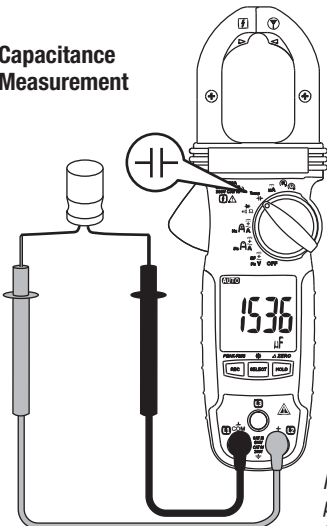

Capacitance (CM-860, CM-960, CMH-600, and CMI-600 only)

Range	Accuracy*
200.0 μF	± (2.0% + 0.4 μF)
2500 μF	± (2.0% + 4 μF)

* For film capacitors (capacitors with negligible dielectric absorption).

Note: For polarized capacitors, attach red probe to positive terminal and black probe to negative terminal of capacitor.

Typical Measurements and Accuracy (cont'd)

Diode Measurement

Diode Test

Measuring Range: 2.000 V
 Accuracy: $\pm (1.5\% + 0.005 \text{ V})$
 Test Current (typical): 0.3 mA
 Open Circuit Voltage (typical):
 < 3.5 VDC

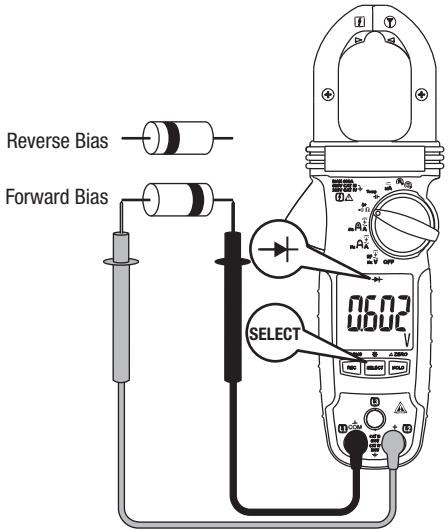

Temperature

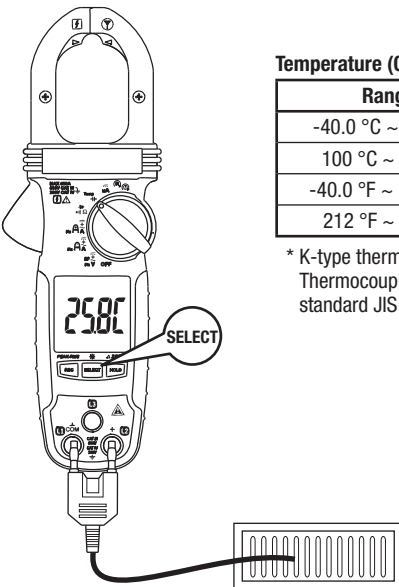

Temperature (CMH-600 and CMI-600)

Range	Accuracy*
-40.0 °C ~ 99.9 °C	$\pm (1.0\% + 0.8 \text{ }^\circ\text{C})$
100 °C ~ 400 °C	$\pm (1.0\% + 1 \text{ }^\circ\text{C})$
-40.0 °F ~ 211.8 °F	$\pm (1.0\% + 1.5 \text{ }^\circ\text{F})$
212 °F ~ 752 °F	$\pm (1.0\% + 2 \text{ }^\circ\text{F})$

* K-type thermocouple accuracy not included.
 Thermocouple supplied with meter meets
 standard JIS C 1602-1981.

Typical Measurements and Accuracy (cont'd)

Electric Field

Note: CM-660 and CM-860 have a dedicated switch position.

Non-contact EF Detection

Typical Voltage	Range at 50 Hz to 60 Hz	LCD Indication
20 V	10 V ~ 36 V	-
55 V	23 V ~ 83 V	--
110 V	59 V ~ 165 V	---
220 V	124 V ~ 330 V	----
440 V	250 V ~ 600 V	-----

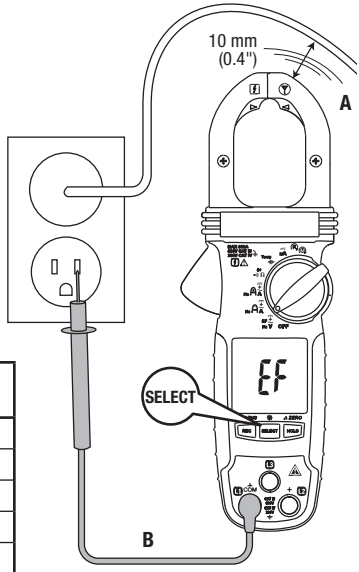

A—Non-contact **OR**

B—Contact, precision measurement

Phase Rotation

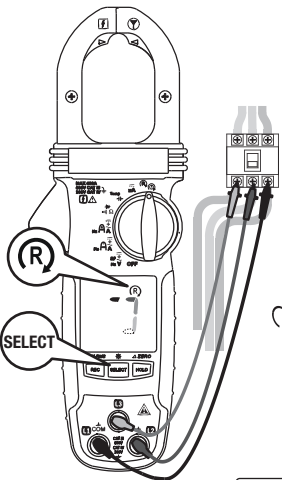

Motor Rotation

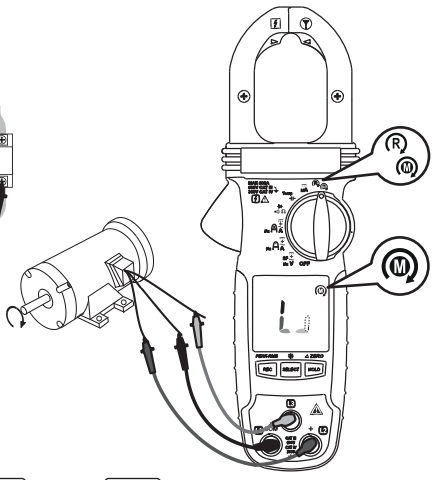

Clockwise



Counterclockwise

Specifications

Display: LCD, 3-5/6 digits 6000 counts

Polarity: Automatic

Update Rate: 5 per second nominal

Operating Conditions:

0 °C to 31 °C (32 °F to 88 °F), relative humidity 0% to 80%

31 °C to 40 °C (88 °F to 104 °F), relative humidity decreasing linearly from 80% to 50%

Pollution Degree: 2

Indoor use only

Altitude: Operating below 2000 m (6500 ft)

Storage Temperature: -20 °C to 60 °C, relative humidity < 80%, with batteries removed

Temperature Coefficient: Nominal 0.15 x (Accuracy) per °C below 18 °C from 0 °C to 18 °C (32 °F to 64.4 °F) and above 28 °C from 28 °C to 40 °C (82.4 °F to 104 °F) or otherwise specified

Sensing: True RMS

E.M.C.:

Meets EN61326-1:2006 (EN55022, EN61000-3-2, EN61000-3-3, EN61000-4-2, EN61000-4-3, EN61000-4-4, , EN61000-4-5, EN61000-4-6, EN61000-4-8, EN61000-4-11)

In an RF field of 1 V/m at a frequency of 405 MHz, DCA and DC+AC A mode (CM-960 and CMI-960): Total Accuracy = Specified Accuracy + 20 digits

In an RF field of 1 V/m resistance mode (all models) and DC μ A mode (CMH-600 and CMI-600): Total Accuracy = Specified Accuracy + 25 digits

In an RF field of 3 V/m, all other modes and models not specified above: Total Accuracy = Specified Accuracy + 20 digits

Safety: Double insulation per UL/IEC/EN61010-1 Ed. 3, IEC/EN61010-2-033 Ed. 1, CAN/CSA C22.2 No. 61010-1 Ed. 3, IEC/EN61010-2-032 Ed. 2 and IEC/EN61010-031 Ed. 1.1 to CAT III 600V and CAT IV 300V AC and DC

Overload Protections:

Jaws:

Current with Frequency Function: 600 A DC/AC RMS at \leq 400 Hz

Terminals:

Voltage and Phase Rotation Function: 660 V DC/920 V AC RMS

All Other Modes and Functions: 600 V DC/AC RMS

Transient Protection: 6.0 kV (1.2/50 μ s surge)

Power Supply: Two 1.5 V AAA batteries (NEDA 24A or IEC LR03)

Low Battery:

Capacitance and Frequency Function: Approximately 2.85 V

All Other Functions: Approximately 2.5 V

Current Consumption:

CM-960 and CMI-600: Typically 13 mA

CM-660, CM-860, and CMH-600: Typically 4.3 mA

APO Timing: Idle for 32 minutes

APO Consumption: 5 μ A typical

Dimensions:

CM-960 and CMI-600: 222 mm x 76 mm x 37 mm (8.7" x 3.0" x 1.4")

CM-660, CM-860, and CMH-600: 217 mm x 76 mm x 37 mm (8.5" x 3.0" x 1.4")

Jaw Opening and Conductor Diameter: 30 mm max (1.18")

Measurement Categories

These definitions were derived from the international safety standard for insulation coordination as it applies to measurement, control, and laboratory equipment. These measurement categories are explained in more detail by the International Electrotechnical Commission; refer to either of their publications: IEC 61010-1 or IEC 60664.

Measurement Category II

Local level. Appliances, portable equipment, and the circuits they are plugged into. Some examples include light fixtures, televisions, and long branch circuits.

Measurement Category III

Distribution level. Permanently installed machines and the circuits they are hard-wired to. Some examples include conveyor systems and the main circuit breaker panels of a building's electrical system.

Measurement Category IV

Primary supply level. Overhead lines and other cable systems. Some examples include cables, meters, transformers, and other exterior equipment owned by the power utility.

Statement of Conformity

Greenlee Textron Inc. is certified in accordance with ISO 9001 (2000) for our Quality Management Systems.

The instrument enclosed has been checked and/or calibrated using equipment that is traceable to the National Institute for Standards and Technology (NIST).

Maintenance

⚠ WARNING

Electric shock hazard:

Before opening the case, remove the test leads from the circuit and shut off the unit.

Failure to observe this warning could result in severe injury or death.

Replacing the Batteries

1. Disconnect the unit from the circuit. Turn the unit OFF.
2. Remove the two screws from the battery access door and remove it.
3. Replace the batteries, making sure to observe the polarity.

Cleaning and Storage

Periodically wipe the case with a damp cloth and mild detergent; do not use abrasives or solvents.

If the meter will not be used for periods longer than 60 days, remove the batteries and store them separately.

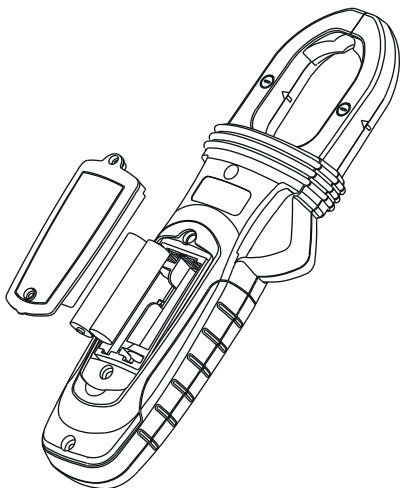

Lifetime Limited Warranty

Greenlee Textron Inc. warrants to the original purchaser of these goods for use that these products will be free from defects in workmanship and material for their useful life, excepting normal wear and abuse. This warranty is subject to the same terms and conditions contained in Greenlee Textron Inc.'s standard one-year limited warranty.

For items not covered under warranty (such as items dropped, abused, etc.), a repair cost quote is available upon request.

Note: Prior to returning any test instrument, please check replaceable batteries or make sure the battery is at full charge.

