



COMPASS™ CR SERIES

Compact Scales

Test Equipment Depot
1-800-517-8431

99 Washington Street
Melrose, MA 02176
Phone 781-665-1400
Toll Free 1-800-517-8431

Visit us at www.TestEquipmentDepot.com



Basic Weighing Capabilities at an Economical Price

The Compass CR series provides basic weighing functionality and competitive performance at an economical price. Features such as a slim, stackable design, and an enlarged weighing platform, make the CR series perfect for a variety of portable weighing applications.

Standard Features:

- **Basic Weighing at a Competitive Price**

The Compass CR series is designed for basic weighing at a competitive price point, and is ideal for use in kitchens, classrooms, offices and more.

- **Space-Saving Stackable Design for Convenient Storage**

The Compass CR series is specially designed for convenient storage. Its slim, space saving design allows users to stack up to 4 scales, saving valuable storage space when the scale is not in use.

- **Enlarged Weighing Platform Allows for Versatile Use**

With an enlarged weighing platform, the Compass CR series can adequately handle a wide range of sample sizes. You will only need one scale on your counter for basic weighing with the CR series.

COMPASS™ CR SERIES Compact Scales

Model	CR221	CR621	CR2200	CR5200
Capacity (g)	220	620	2200	5200
Readability (g)	0.1		1	
Span Calibration Mass (Not Included)	200 g	500 g	1 kg	2 kg
Stabilization Time (s)	2			
Construction	ABS housing & pan			
Calibration	User-selectable external span / Digital with external weight			
Tare Range	Full capacity by subtraction			
Weighing Units*	g, ozt, dwt, oz, lb:oz			
Application Modes	Weighing			
Power Requirement	3 AA batteries (included) or AC adapter (not included)			
Typical Battery Life	300 hours			
Display Type	Liquid crystal display (LCD)			
Display Size	0.6 in. / 15 mm digits			
Pan Size (W × D)	5 × 5.2 in. / 125 × 132 mm			
Balance Dimensions (W × D × H)	5.5 × 8.1 × 1.6 in. / 140 × 205 × 41 mm			
Shipping Dimensions (W × D × H)	6.7 × 9.3 × 2.2 in. / 170 × 235 × 55 mm			
Net Weight	0.9 lb / 0.4 kg			
Shipping Weight	1.3 lb / 0.6 kg			

*Availability is dependent on model.

Other Standard Features and Equipment

ABS housing and pan, slip-resistant feet, stability indicator, mechanical and software overload/underload protection, auto shut-off

Compliance

- **Product Safety:** IEC/EN 61010-1; CAN/CSA C22.2 No. 61010-1; UL Std. No. 61010-1
- **Electromagnetic Compatibility:** IEC/EN 61326-1 Class B, Basic environments; FCC Part 15 Class B; Canada ICES-003 Class B
- **Compliance Marks:** CE; RCM

Accessories

- Carrying Case30467763
- Bowl, 1050 mL.....80850075
- Adapter with plugs (EU-US-UK-AU-KR).....30467987

Dimensions

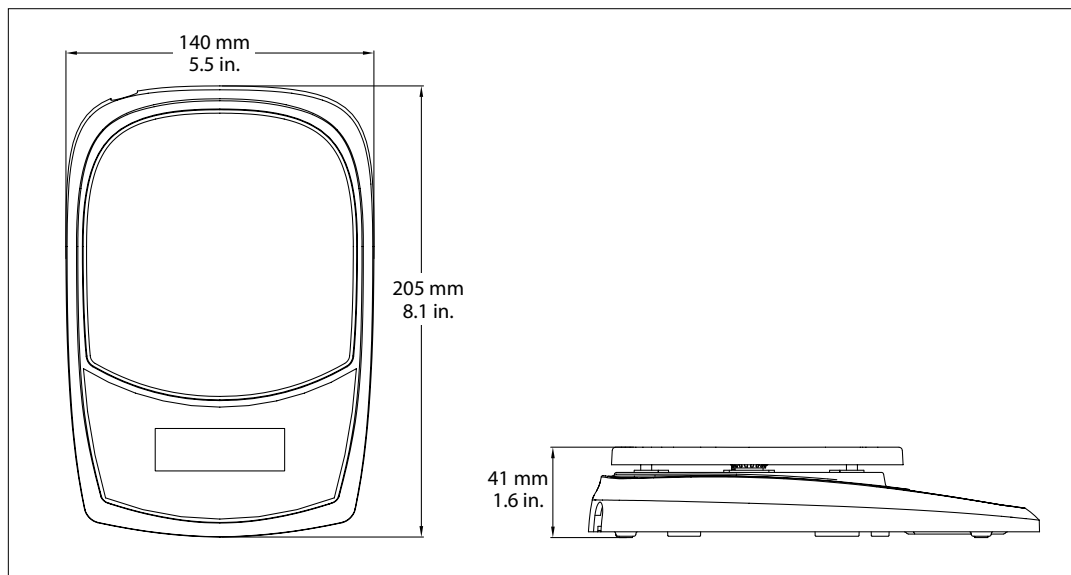

99 Washington Street
Melrose, MA 02176
Phone 781-665-1400
Toll Free 1-800-517-8431

Visit us at www.TestEquipmentDepot.com

80775691 20181205 © Copyright OHAUS Corporation

The management system governing the manufacture of this product is ISO 9001:2015 certified.

