



COMPASS™ CX SERIES

Compact Scales

**Test Equipment
Depot**
1-800-517-8431

99 Washington Street
Melrose, MA 02176
Phone 781-665-1400
Toll Free 1-800-517-8431

Visit us at www.TestEquipmentDepot.com



Designed with Energy Efficient Weighing in Mind for Workplace & In-the-Field Weighing

Designed with energy efficiency in mind, the Compass CX series offers a battery life of up to 1,000 continuous hours, allowing for uninterrupted operation. Featuring a slim, stackable and light-weight design, the CX fits ideally in lab, industrial, education, and even household settings. The streamlined two-button operation means that the balance can be operated easily, and large backlit LCD display enables easy viewing of weighing results.

Standard Features:

- **Low Power Consumption Design Allows for Uninterrupted Operation**

Designed with energy efficiency in mind, the Compass CX series features alkaline batteries capable of up to 1,000 hours of continuous use, providing peace of mind for daily weighing applications.

- **Improved Functionality with Large Backlit LCD and Two-Button Operation**

Combined with a simplified two-button operation, the Compass CX's large backlit display increases readability in dim lighting conditions, and makes it easier to view results from a distance.

- **Practical Space-Saving Design for Convenient Storage**

The Compass CX comes in an ingenious space-saving design, which allows you to stack up to 4 scales to save storage space. Additionally, the CX features a standard stainless steel pan for durable use.

COMPASS™ CX SERIES Compact Scales

Model	CX221	CX621	CX1201	CX2200	CX5200
Capacity (g)	220	620	1200	2200	5200
Readability (g)	0.1			1	
Span Calibration Mass (Not Included)	200 g	500 g	1 kg		2 kg
Stabilization Time (s)	1.5		2	1.5	
Construction	ABS housing and stainless steel pan				
Calibration	User-selectable external span / Digital with external weight				
Tare Range	Full capacity by subtraction				
Weighing Units*	g, N, oz, lb:oz				
Application Modes	Weighing				
Power Requirement	3 AA batteries (included) or AC adapter (not included)				
Typical Battery Life	1,000 hours				
Display Type	Liquid crystal display (LCD) with backlight				
Display Size	0.71 in. digits / 18 mm				
Pan Size (W × D)	5 in × 5.6 / 128 × 142 mm				
Balance Dimensions (W × D × H)	5.3 × 7.9 × 1.6 in. / 135 × 201 × 41 mm				
Shipping Dimensions (W × D × H)	6.7 × 9.3 × 2.2 in. / 170 × 235 × 55 mm				
Net Weight	1.1 lb / 0.51 kg				
Shipping Weight	1.5 lb / 0.7 kg				

*Availability is dependent on model.

Other Standard Features and Equipment

ABS housing, slip-resistant feet, stability indicator, mechanical and software overload/underload protection, low battery indicator, auto shut-off

Compliance

- **Product Safety:** IEC/EN 61010-1; CAN/CSA C22.2 No. 61010-1; UL Std. No. 61010-1
- **Electromagnetic Compatibility:** IEC/EN 61326-1 Class B, Basic environments; FCC Part 15 Class B; Canada ICES-003 Class B
- **Compliance Marks:** CE; RCM

Accessories

Carrying Case	30467763
Bowl, 1050 mL	80850075
Adapter, 5V 1A, US plug	30330714
Adapter, 5V 1A, AU plug	30333865
Adapter, 5V 1A, EU plug	30333866
Adapter, 5V 1A, UK plug	30333867
Carat Bowl XS	12102565
Carat Bowl	30020842

Dimensions

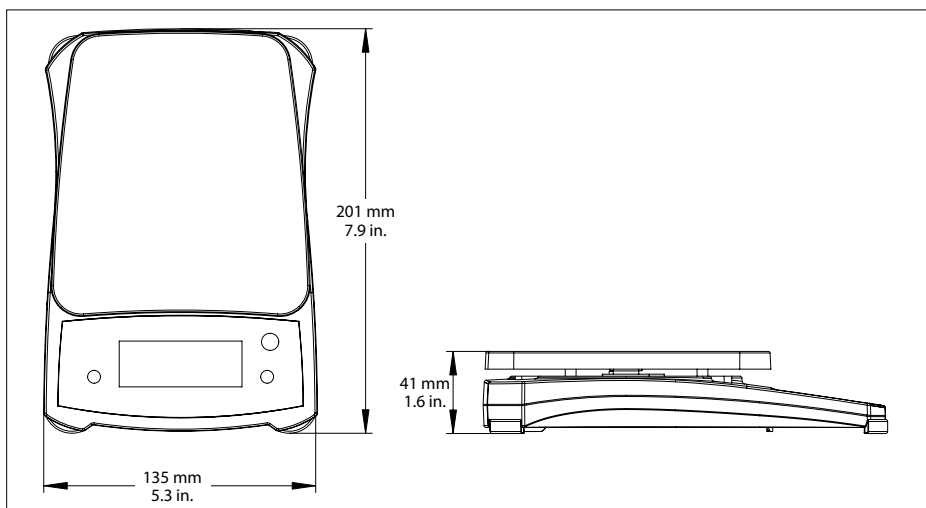

99 Washington Street
Melrose, MA 02176
Phone 781-665-1400
Toll Free 1-800-517-8431

Visit us at www.TestEquipmentDepot.com

80775678 20181205 © Copyright OHAUS Corporation

The management system governing the manufacture of this product is ISO 9001:2015 certified.

