

THIS IS ISSUED IN STRICT CONFIDENCE THAT IT IS NOT USED AS A BASIS FOR MANUFACTURE OR SALE AND THAT IT IS NOT COPIED, REPRINTED OR DISCLOSED TO A THIRD PARTY EITHER WHOLLY OR IN PART WITHOUT THE PRIOR WRITTEN CONSENT OF CAL TEST ELECTRONICS, INC.

Test Equipment Depot
 99 Washington St. Melrose MA, 02176
 1.800.517.8431 | 781.665.0780 (Fax)

Visit us at www.TestEquipmentDepot.com

REVISIONS			
REV.	DESCRIPTIONS	DATE	APPROVED
-	CLASS A RELEASED	7/12/99	
A	NOTE 3: ADDED IEC 61010-031 1,000 V CAT IV & RoHS; REVISED PLUG CONFIGURATION, PAGE 2.	2/7/05	

- 4mm BANANA PLUG LEAD, SHEATHED PLUG TO SHEATHED PLUG, 0.75mm², SILICONE JACKETED WIRE. CE MARK AND CSA LISTED (US AND CANADA).
- SPECIFICATIONS:
 WIRE:
 REINFORCED SILICONE (-60° C TO +180° C)
 195x0.07mm STRANDED BARE COPPER, 0.75mm² CROSS SECTION, 18 AWG, Ø.146±.008 (Ø3.7±0.2mm) O.D.

 INSULATED HOUSING:
 POLYPROPYLENE THERMOPLASTIC, UL94V-0.

 CONTACT:
 4mm, 9 LEAF, BERYLLIUM COPPER, NICKEL PLATED.
 PLUG BODY:
 BRASS, NICKEL PLATED.
- RATING:
 IEC 61010-031 @ 1,000 V CAT IV P2.
 CURRENT: 12 A MAX.
 INTERNAL RESISTANCE: 55 mΩ MAX @ 200 cm LENGTH.
 TEMPERATURE: -25° C TO +80° C.

 CE DECLARATION OF CONFORMITY, LVD
 CONFORMS TO RoHS DIRECTIVE 2002/95/EC.



PART NUMBER

CT2162-L-#

- COLOR:
- 0 - BLACK
 - 2 - RED
 - 4 - YELLOW
 - 5 - GREEN
 - 6 - BLUE
 - 9 - WHITE

LENGTH: (CENTIMETERS)
 STANDARDS: 10, 25, 50, 100, 150, 200

THIRD ANGLE PROJECTION		UNLESS OTHERWISE SPECIFIED DIMENSIONS ARE IN INCHES TOLERANCES ARE: FRACTIONS DECIMALS ± 1/32 .XX ± .02 .XXX ± .005 DO NOT SCALE DRAWING		CONTRACT NO.		Cal Test Electronics 22820 Savi Ranch Parkway Yorba Linda, CA			
		MATERIAL		APPROVALS	DATE	TITLE LEAD, 4mm SHEATHED PLUGS, 0.75mm², SILICONE			
		FINISH		DRAWN					
NEXT ASSY		USED ON		CHECKED		SIZE	CAGE CODE	DWG. NO.	REV.
APPLICATION				ENGR.		A	43F45	P217600	A
				DESIGN ACTIVITY		SCALE	NONE	SHEET	1 OF 2

THIS IS ISSUED IN STRICT CONFIDENCE THAT IT IS NOT USED AS A BASIS FOR MANUFACTURE OR SALE AND THAT IT IS NOT COPIED, REPRINTED OR DISCLOSED TO A THIRD PARTY EITHER WHOLLY OR IN PART WITHOUT THE PRIOR WRITTEN CONSENT OF CAL TEST ELECTRONICS, INC.

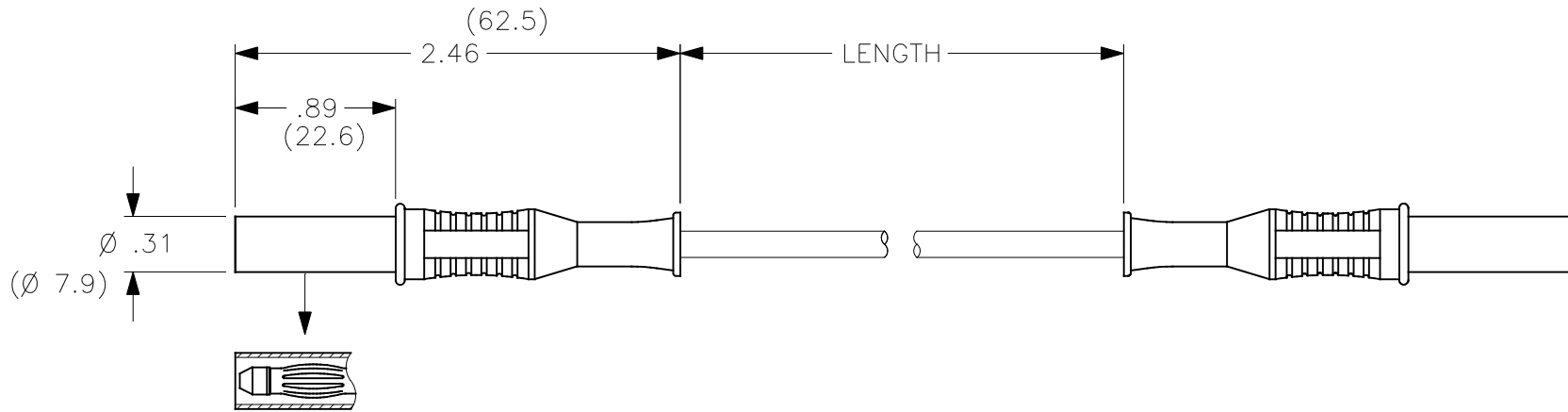

DRAWN		WDH	7/12/99	SIZE	A	CAGE CODE	43F45	DWG. NO.	P216200	REV.	A
CHECKED				SCALE	1:1			SHEET	2		