

THIS IS ISSUED IN STRICT CONFIDENCE THAT IT IS NOT USED AS A BASIS FOR MANUFACTURE OR SALE AND THAT IT IS NOT COPIED, REPRINTED OR DISCLOSED TO A THIRD PARTY EITHER WHOLLY OR IN PART WITHOUT THE PRIOR WRITTEN CONSENT OF CAL TEST ELECTRONICS, INC.

Test Equipment Depot
 99 Washington St. Melrose MA, 02176
 1.800.517.8431 | 781.665.0780 (Fax)
 © Visit us at www.TestEquipmentDepot.com

REVISIONS			
REV.	DESCRIPTIONS	DATE	APPROVED
-	CLASS A RELEASED	7/12/04	

- TEST PROBE LEAD w/4mm SPRING CONTACT TIP, 0.75mm², SILICONE JACKETED WIRE.
- SPECIFICATIONS:
 WIRE:
 DOUBLE INSULATED SILICONE (-60° C TO +180° C)
 195x0.07mm STRANDED BARE COPPER, 0.75mm² CROSS SECTION (18AWG), Ø.146±.008 (Ø3.7±0.2mm) O.D.

 INSULATED HOUSINGS:
 PA6 (NYLON) THERMOPLASTIC.
 UL94V-0.

 CONTACTS:
 PLUG BODY & TIP: BRASS, NICKEL PLATED
 CONTACTS: 4mm, 9 LEAF-BECU, NICKEL PLATED.
 INSULATED TIP ON PLUG BODY, GREY
- RATING:
 1,000V CATIII P2 PER IEC61010-031
 CURRENT: 12A MAX.
 TEMPERATURE: -20° C TO +80° C.

 CE DECLARATION OF CONFORMITY:
 VOLTAGE: 1000V CATIII P2, IEC61010-031 (HANDHELD)
 CURRENT: 12A MAX.

PART NUMBER

CT2309-L-#



COLOR: **0** - BLACK
2 - RED

LENGTH: (CENTIMETERS)
 STANDARDS: **100, 150**

THIRD ANGLE PROJECTION		UNLESS OTHERWISE SPECIFIED DIMENSIONS ARE IN INCHES TOLERANCES ARE: FRACTIONS DECIMALS ± 1/32 .XX ± .02 .XXX ± .005 DO NOT SCALE DRAWING	CONTRACT NO.		Cal Test Electronics 22820 Savi Ranch Parkway Yorba Linda, CA			
			APPROVALS	DATE	TITLE TEST PROBE LEAD w/4mm CONTACT TIP, 0.75mm², SILICONE WIRE			
		MATERIAL	DRAWN WDH	7/12/04	SIZE A	CAGE CODE 43F45	DWG. NO. P230900	REV. -
		FINISH	CHECKED		SCALE NONE	SHEET 1 OF 2		
NEXT ASSY	USED ON		ENGR.					
APPLICATION			DESIGN ACTIVITY					

THIS IS ISSUED IN STRICT CONFIDENCE THAT IT IS NOT USED AS A BASIS FOR MANUFACTURE OR SALE AND THAT IT IS NOT COPIED, REPRINTED OR DISCLOSED TO A THIRD PARTY EITHER WHOLLY OR IN PART WITHOUT THE PRIOR WRITTEN CONSENT OF CAL TEST ELECTRONICS, INC.

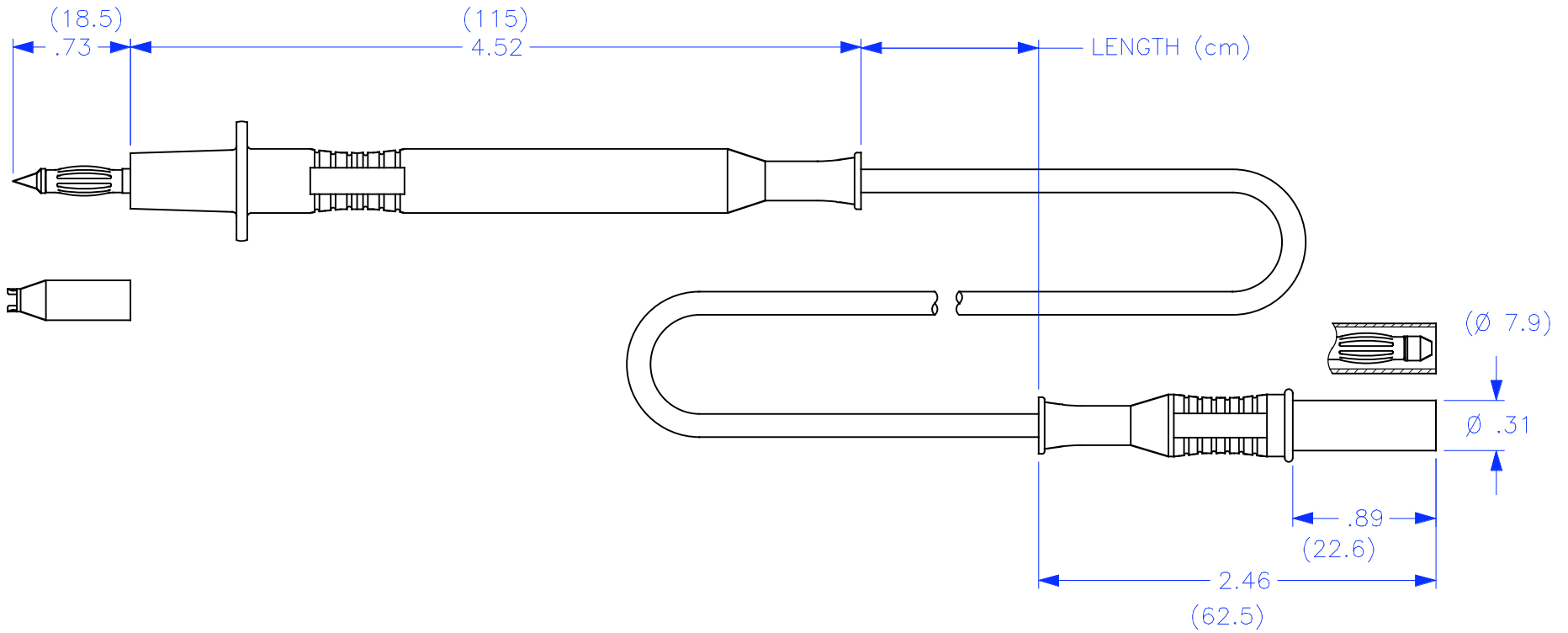

DRAWN	WDH	7/12/04	SIZE	A	CAGE CODE	43F45	DWG. NO.	P230900	REV.	-
CHECKED			SCALE	1:1			SHEET	2		