

THIS IS ISSUED IN STRICT CONFIDENCE THAT IT IS NOT USED AS A BASIS FOR MANUFACTURE OR SALE AND THAT IT IS NOT COPIED, REPRINTED OR DISCLOSED TO A THIRD PARTY EITHER WHOLLY OR IN PART WITHOUT THE PRIOR WRITTEN CONSENT OF CAL TEST ELECTRONICS, INC.

Test Equipment Depot - 800.517.8431 - 5 Commonwealth Ave, MA 01801
TestEquipmentDepot.com

REVISIONS			
REV.	DESCRIPTION	DATE	APPROVED
A	INITIAL RELEASE	11/15/2023	B. Hansen

NOTES:

- ALL SPECIFICATIONS SUBJECT TO CHANGE WITHOUT NOTICE.
- ADAPTER TO MEET OR EXCEED ALL SPECIFICATIONS PER MIL-PRF-39012.
- MATING DIMENSIONS IN ACCORDANCE WITH MIL-STD-348.
- FREQUENCY RANGE SPECIFICATIONS ARE FOR REFERENCE AND ARE DEPENDENT ON CABLE TYPE AND OTHER APPLICATION SPECIFIC CONDITIONS.
- MATERIAL:
 - BODY: BRASS, NICKEL PLATED
 - CENTER CONTACT: BRASS, GOLD PLATED
 - HEX NUT: BRASS, NICKEL PLATED
 - LOCKWASHER: BRASS, NICKEL PLATED
 - DIELECTRIC: DELRIN
- ELECTRICAL:
 - IMPEDANCE: 50Ω
 - FREQUENCY: DC - 2 GHz
 - WORKING VOLTAGE: 500 Vrms
- MAXIMUM PANEL THICKNESS: 2.0 mm
- MECHANICAL:
 - TEMPERATURE RANGE: -20°C TO +80°C
- RoHS AND REACH COMPLIANT

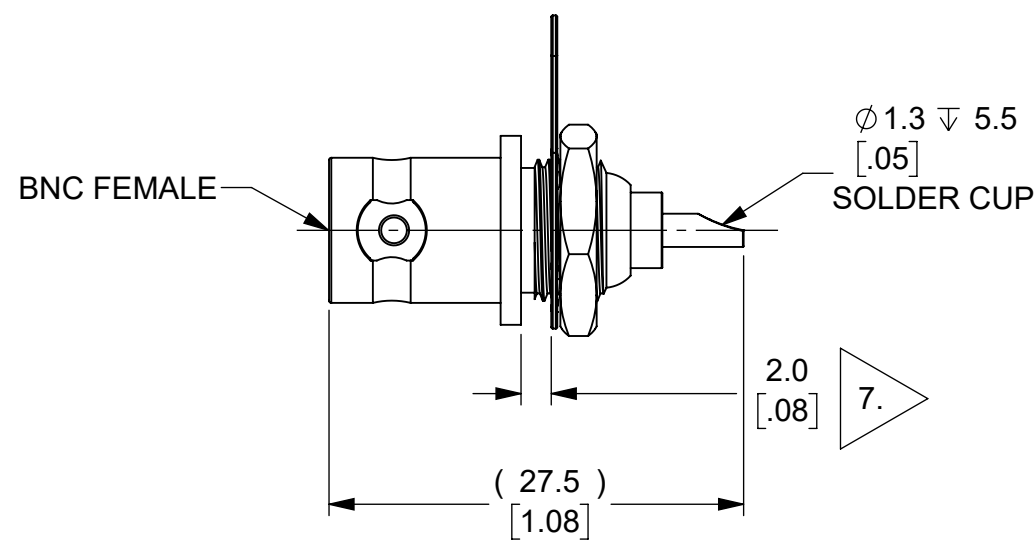
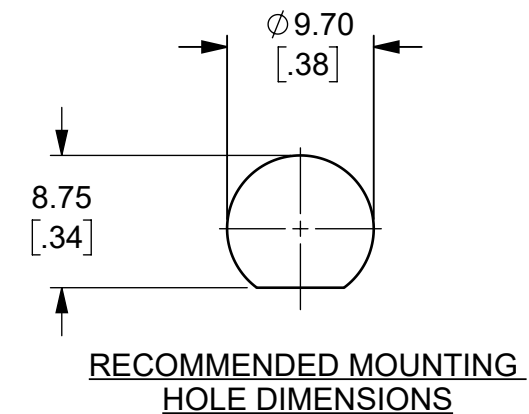
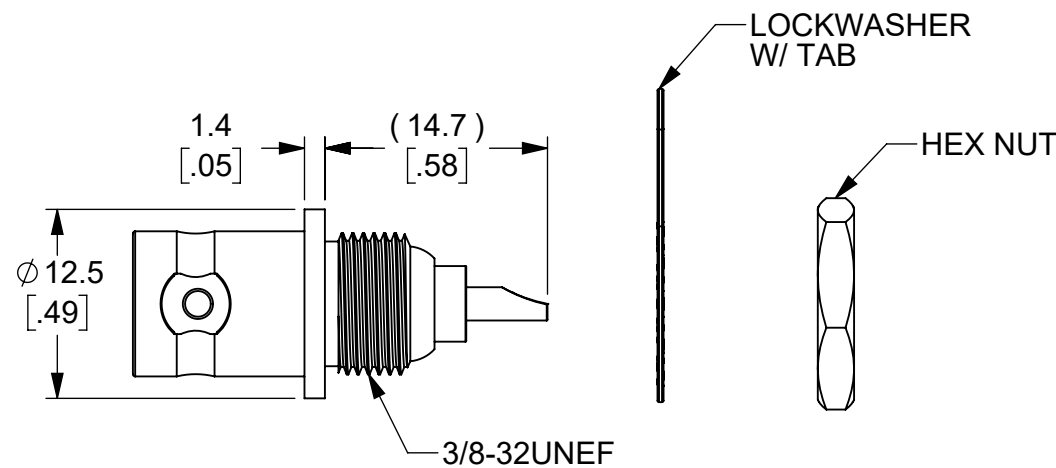

ISOMETRIC VIEW
FULL SCALE

CT4512	BULKHEAD MOUNT	IN-SERIES CONNECTOR
MODEL NUMBER	CONFIGURATION	NOTES / REFERENCE

MODEL NUMBER TABLE

THIRD ANGLE PROJECTION	UNLESS OTHERWISE SPECIFIED DIMENSIONS ARE IN MILLIMETERS TOLERANCES ARE: X.X = ±0.5 X.X* = ±0.5* X.XX = ±0.25 X.XXX = ±0.125 DO NOT SCALE DRAWING	PROJECT NO.	22820 Savi Ranch Prky. Yorba Linda, CA 92887 USA
		APPROVALS	
REFERENCE	MATERIAL SEE NOTES	DRAWN	TITLE CONNECTOR, BNC FEMALE, BULKHEAD MOUNT w/SOLDER CUP
		CHECKER	
	TREATMENT NONE	ENGR.	SIZE B
	FINISH SEE NOTES	DESIGN ACTIVITY	
			DWG. NO. CT4512
			REV. A
		SCALE	SHEET 1 OF 1
		2:1	