

# 9mm Magnetic Connector, 4mm Sheathed Jack, Right-Angle

## CT4519



### Features:

- IEC 61010-031 Safety rated
- Magnetic connector to 4 mm sheathed jack
- Reinforced insulation
- Higher category working voltage
- 9 mm Diameter magnetic connector
- CE Mark
- RoHS 2 Compliant

### Description:

Cal Test's new CT4519 adaptor features a magnetic connector to a 4 mm jack. Primarily designed for application on circuit breakers, terminal blocks, and photovoltaic panels, this adaptor incorporates a magnetic tip that provides a quick hands-free connection to ferrous conductors. Made with reinforced insulation, its category rating ensures a safe connection in environments where circuit breakers and photovoltaic panels are commonly located. The CT4519 is a great choice when an easy, reliable, and safe connection is desired.

Available in different colors. See Order Information on page 2.

For additional product information, cross-references, or other test accessory information, visit [www.caltestelectronics.com](http://www.caltestelectronics.com).

### Specifications:

- Voltage Rating: 1500 VDC CAT III / 1000 V CAT IV
- Max Current: 4 A
- Insulation: Polypropylene (PP)
- Magnet: N35
- Contact: Brass, Nickel Plated
- Working Temperature: -20°C to +80°C

### Outline Drawing: (not to scale)

Dimensions: mm [in]

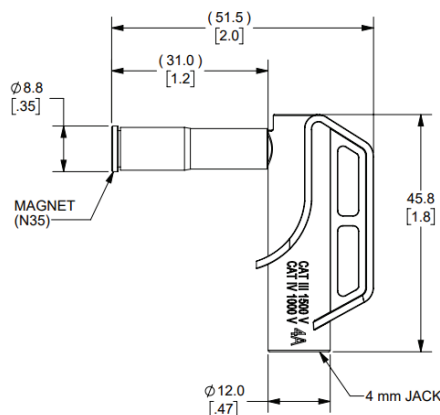

Specifications and appearance subject to change without notice  
[www.caltestelectronics.com](http://www.caltestelectronics.com)

**Ordering Information:**

**CT4519-#**

Magnetic Connector, 4 mm Sheathed Jack, Right-Angle

#Colors Available:

-0 Black, -1 Brown, -2 Red, -5 Green, -6 Blue, -8 Grey

Order Example:

CT4519-2 (CT4519 Magnetic Conector, red)

