



DC current sensors

Associated with DIRIS Digiware DC

Current sensors



torc_072_a.eps

Solid-core sensors 50 ... 600 A



torc_071_a.eps

Split-core sensors 50 ... 500 A



torc_068_a.eps

Solid-core sensors 850 ... 5000 A



torc_066_a.eps

Split-core sensors 800 ... 2000 A

The solution for

- > Data center
- > Telecommunication
- > Renewable power
- > Transportation



Strong points

- > Plug & Play
- > Wide selection of ratings
- > Simplified installation

Compliance with standards

- > UL 61010
guide NMTR
file E189713



- > IEC 61010-1



Function

The **DC current sensors** measure the DC load currents of an electrical installation and transmit information to the DIRIS Digiware Idc measurement modules via an RJ12 cable.

The range comprises solid-core and split-core sensors ranging from 50 to 5000 A in various sizes allowing them to be used in new or existing electrical installations.

Up to 3 different DC sensors can be connected to the same DIRIS Digiware Idc module.

Advantages

Plug & Play

- A quick RJ12 connection makes wiring easy and reliable.
- Fast configuration of the sensor's rating.

Flexible

- A complete range of solid-core and split-core sensors from 50 to 5000 A designed for new or existing electrical installations.

Installation

- Easy to install.
- Ideal for installations with limited space available.
- Only 4 different frame sizes cover a wide measurement range.
- Color-coded cables for ease of identification, and to prevent wiring errors.

Dimensions (in/mm)

Solid-core sensors 50 ... 600 A (frame size 1)

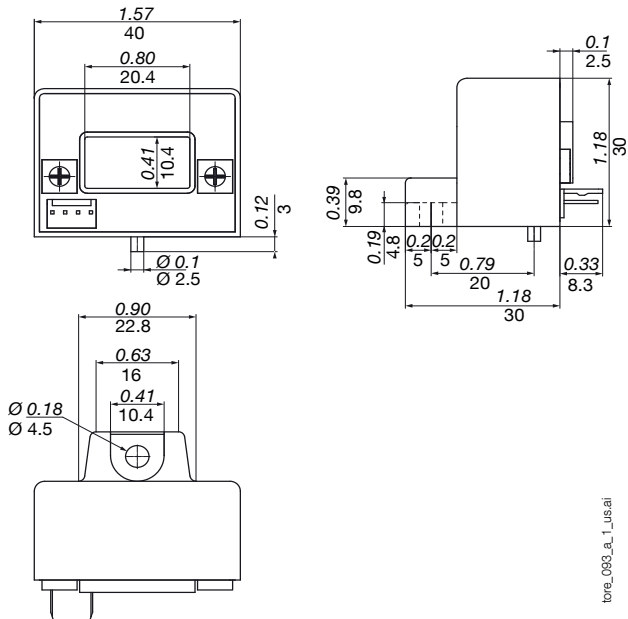

Solid-core sensors 850 ... 5000 A (frame size 2)

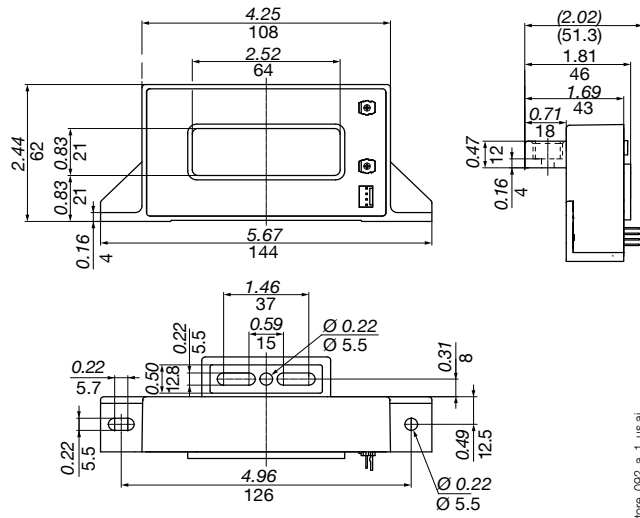

Split-core sensors 50 ... 500 A (frame size 1)

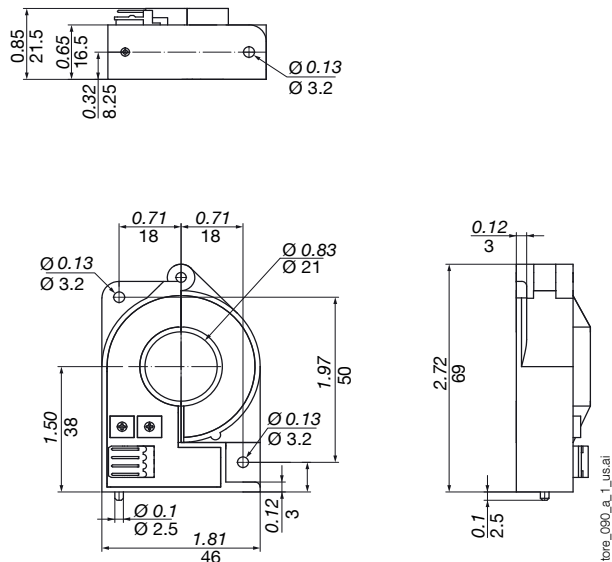

Split-core sensors 800 ... 2000 A (frame size 2)

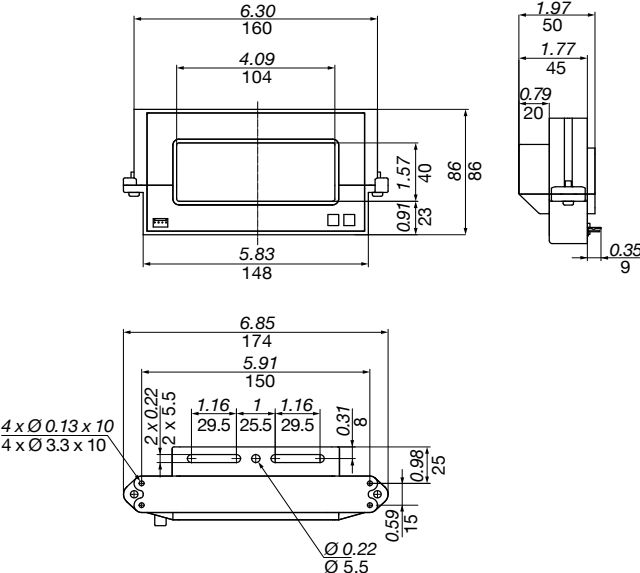

DC current sensors

Associated with DIRIS Digiware DC

Connections

DC current is measured by external sensors connected to the DIRIS Digiware I-3xdc modules via RJ12-Molex cables. Connection of the current sensors is quick and error-free. A wide range of current sensors is available from Socomec to suit all installations and applications including split-core current sensors for retrofit applications.

The DC current sensors have the following technical characteristics:

- Open-loop Hall effect sensors.
- Solid-core or split-core.
- Power supply voltage: ± 15 V.
- Power supply current: ± 25 mA depending on the sensor.
- Output voltage: ± 4 V.
- 4-point male Molex terminal strip.
- Measurement range: 16 to 5000 A.
- Category III overvoltage.

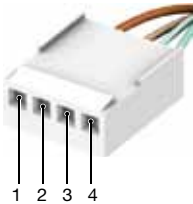

- PIN 1: + 15 V (+ Vc)
- PIN 2: - 15 V (- Vc)
- PIN 3: sensor input (M)
- PIN 4: 0 V sensor (0)

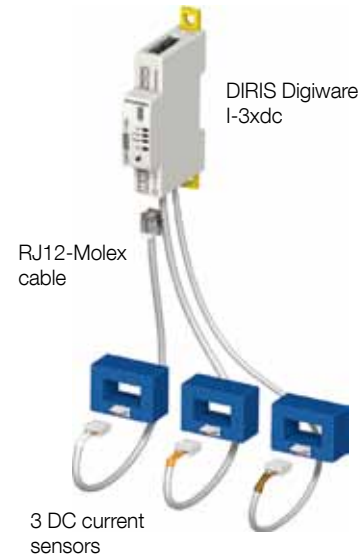

Technical characteristics

Type of current sensor	Open-loop Hall effect
Connection	Specific Socomec cable with RJ12-Molex connectors
Accuracy of current measurement	Solid-core sensors: 50 ... 600 A: < 1% Solid-core sensors: 850 ... 5000 A: < 1% Split-core sensors: 50 ... 500 A: < 2% Split-core sensors: 800 ... 2000 A: < 2%

Weight	Solid-core sensors 50 ... 600 A	60 g / 2.12 oz
	Solid-core sensors 850 ... 5000 A	450 g / 15.87 oz
	Split-core sensors 50 ... 500 A	80 g / 2.82 oz
	Split-core sensors 800 ... 2000 A	590 g / 20.8 oz
Operating temperature	Solid-core sensors 50 ... 600 A	-10 ... +80 °C / +14 °F ... +176 °F
	Solid-core sensors 850 ... 5000 A	-25 ... +85 °C / -13 °F ... +185 °F
	Split-core sensors 50 ... 500 A	-10 ... +70 °C / +14 °F ... +158 °F
	Split-core sensors 800 ... 2000 A	-10 ... +70 °C / +14 °F ... +158 °F
Storage temperature	Solid-core sensors 50 ... 600 A	-25 ... +80 °C / -13 °F ... +176 °F
	Solid-core sensors 850 ... 5000 A	-25 ... +85 °C / -13 °F ... +185 °F
	Split-core sensors 50 ... 500 A	-20 ... +85 °C / -4 °F ... +185 °F
	Split-core sensors 800 ... 2000 A	-25 ... +85 °C / -13 °F ... +185 °F

References

DC current sensors	Reference
Solid-core sensors (frame size 1)	
50 A	4829 0700
100 A	4829 0701
200 A	4829 0702
300 A	4829 0703
400 A	4829 0704
500 A	4829 0705
600 A	4829 0706
Solid-core sensors (frame size 2)	
850 A	4829 0707
1000 A	4829 0708
1500 A	4829 0709
2000 A	4829 0710
2500 A	4829 0711
5000 A	4829 0712
Split-core sensors (frame size 1)	
50 A	4829 0750
100 A	4829 0751
200 A	4829 0752
300 A	4829 0753
400 A	4829 0754
500 A	4829 0755
Split-core sensors (frame size 2)	
800 A	4829 0756
1000 A	4829 0757
1500 A	4829 0758
2000 A	4829 0759

RJ12-MOLEX cables		
Number of cables	Length of cables	Reference
3	0.98 feet / 0.3 m	4829 0782
3	1.64 feet / 0.50 m	4829 0783
3	3.28 feet / 1 m	4829 0784
3	6.56 feet / 2 m	4829 0785
1	16.4 feet / 5 m	4829 0786

Test Equipment Depot 99 Washington Street
Melrose, MA 02176
Phone 781-665-1400
1-800-517-8431 Toll Free 1-800-517-8431

 Visit us at www.TestEquipmentDepot.com