



DEFENDER® 3000

Bench Scales



Counting function is not legal-for-trade

Bench Scales for Basic Industrial Applications

The Defender 3000 Series bench scales are ideal for general weighing, simple counting and checkweighing applications in production, packaging, warehouse, inventory, shipping and receiving areas. The Defender 3000 Series features a simple, yet rugged tubular-frame base design and indicators with tactile keys, multicolor backlit LCD display, AC or battery operation and flexible mounting capabilities.

Unique Features:

- Results are clearly shown using the large, bright backlit LCD display. In Checkweighing mode display changes color (yellow/green/red) to alert when within the target weight range.
- This tough industrial scale features a 304-stainless steel platform, powder-coated steel tubular frame, column and aluminum load cell. Indicator features a durable ABS housing and powder coated steel mounting bracket.
- Features software for Parts Counting, Checkweighing and Totalization. Includes RS232 with optional second port USB Device or Ethernet for printing or data connectivity.

DEFENDER® 3000 Bench Scales

Specifications

Column Mount Bench Scales

Model	i-D33P15B1R1	i-D33P30B1R1	i-D33P75B1R1	i-D33P75B1L2	i-D33P150B1L2
Capacity x Default Readability	15 kg x 2 g 30 lb x 0.005 lb 480 oz x 0.1 oz	30 kg x 5 g 60 lb x 0.01 lb 960 oz x 0.2 oz	75 kg x 10 g 150 lb x 0.02 lb 2,400 oz x 0.5 oz	75 kg x 10 g 150 lb x 0.02 lb 2,400 oz x 0.5 oz	150 kg x 20 g 300 lb x 0.05 lb 4,800 oz x 1 oz
Capacity x Certified/Approved Readability	15 kg x 5 g 30 lb x 0.01 lb 480 oz x 0.2 oz	30 kg x 10 g 60 lb x 0.02 lb 960 oz x 0.5 oz	75 kg x 50 g 150 lb x 0.05 lb 2,400 oz x 1 oz	75 kg x 50 g 150 lb x 0.05 lb 2,400 oz x 1 oz	150 kg x 50 g 300 lb x 0.1 lb
Maximum Displayed Resolution	1:7,500	1:6,000	1:7,500		
Linearity/Repeatability	±1d				
Maximum Certified Resolution	1:3,000				
Indicator	ABS indicator				
Column	330 mm / 13 in high powder-coated steel			680 mm / 26.8 in high powder-coated steel	
Base Construction	Stainless steel removable weighing platform, powder-coated steel base construction, silicon sealed aluminum loadcell against moisture				
Safe Overload Capacity	150% of maximum capacity				
Stabilization Time	Within 1 second				
Operating Temperature Range	14°F to 104°F / -10°C to 40°C				
Scale Dimensions (A x B x C x D x E x F)	355 x 305 x 121.8 x 75 x 541.6 x 489.1 mm 14 x 12 x 4.8 x 3 x 21.3 x 19.3 in			550 x 420 x 134 x 80 x 896.1 x 685.6 mm 21.7 x 16.5 x 5.3 x 3.1 x 35.3 x 27 in	
Shipping Dimensions (L x W x H)	642 x 497 x 212 mm 25.3 x 19.6 x 8.3 in			857 x 564 x 225 mm 33.7 x 22.2 x 8.9 in	
Approx. Net Weight	10.4 kg / 22.9 lb			16.9 kg / 37.3 lb	
Approx. Shipping Weight	13.4 kg / 29.5 lb			21 kg / 46.2 lb	

Model	i-D33P150B1X2	i-D33P300B1X2	i-D33P300B1V3	i-D33P600B1V3
Capacity x Default Readability	150 kg x 20 g 300 lb x 0.05 lb 4,800 oz x 1 oz	300 kg x 50 g 600 lb x 0.1 lb	300 kg x 50 g 600 lb x 0.1 lb	600 kg x 100 g 1200 lb x 0.2 lb
Capacity x Certified/Approved Readability	150 kg x 50 g 300 lb x 0.1 lb	300 kg x 100 g 600 lb x 0.2 lb	300 kg x 100 g 600 lb x 0.2 lb	600 kg x 200 g 1200 lb x 0.5 lb
Maximum Displayed Resolution	1:7,500	1:6,000		
Linearity/Repeatability	±1d			
Maximum Certified Resolution	1:3,000			
Indicator	ABS indicator			
Column	680 mm / 26.8 in high powder-coated steel		980 mm / 38.6 in high powder-coated steel	
Base Construction	Stainless steel removable weighing platform, powder-coated steel base construction, silicon sealed aluminum loadcell against moisture			
Safe Overload Capacity	150% of maximum capacity			
Stabilization Time	Within 1 second			
Operating Temperature Range	14°F to 104°F / -10°C to 40°C			
Scale Dimensions (A x B x C x D x E x F)	650 x 500 x 150 x 90 x 894.6 x 784.6 mm 25.6 x 19.7 x 5.9 x 3.5 x 35.2 x 30.9 in		800 x 600 x 154.1 x 90 x 1194.6 x 933.1 mm 31.5 x 23.6 x 6.1 x 3.5 x 47 x 36.7 in	
Shipping Dimensions (L x W x H)	1,022 x 687 x 247 mm 40.2 x 27 x 9.7 in		1,165 x 780 x 235 mm 45.9 x 30.7 x 9.3 in	
Approx. Net Weight	27 kg / 59.6 lb		45.5 kg / 100.3 lb	
Approx. Shipping Weight	30.5 kg / 67.3 lb		49.5 kg / 109 lb	

DEFENDER® 3000 Bench Scales

Specifications

Front Mount Bench Scales

Model	i-D33P15B1R5	i-D33P30B1R5	i-D33P75B1R5	i-D33P75B1L5	i-D33P150B1L5	i-D33P150B1X5	i-D33P300B1X5
Capacity x Default Readability	15 kg x 2 g 30 lb x 0.005 lb 480 oz x 0.1 oz	30 kg x 5 g 60 lb x 0.01 lb 960 x 0.2 oz	75 kg x 10 g 150 lb x 0.02 lb 2,400 oz x 0.5 oz	75 kg x 10 g 150 lb x 0.02 lb 2,400 oz x 0.5 oz	150 kg x 20 g 300 lb x 0.05 lb 4,800 oz x 1 oz	150 kg x 20 g 300 lb x 0.05 lb 4,800 oz x 1 oz	300 kg x 50 g 600 lb x 0.1 lb
Capacity x Certified/Approved Readability	15 kg x 5 g 30 lb x 0.01 lb 480 oz x 0.2 oz	30 kg x 10 g 60 lb x 0.02 lb 960 oz x 0.5 oz	75 kg x 50 g 150 lb x 0.05 lb 2,400 oz x 1 oz	75 kg x 50 g 150 lb x 0.05 lb 2,400 oz x 1 oz	150 kg x 50 g 300 lb x 0.1 lb	150 kg x 50 g 300 lb x 0.1 lb	300 kg x 100 g 600 lb x 0.2 lb
Maximum Displayed Resolution	1:7,500	1:6,000	1:7,500				1:6,000
Linearity/ Repeatability	±1d						
Maximum Certified Resolution	1:3,000						
Indicator	ABS indicator						
Mount	304 stainless steel front-mount bracket with handle						
Base Construction	Stainless steel removable weighing platform, powder-coated steel base construction, silicon sealed aluminum loadcell against moisture						
Safe Overload Capacity	150% of maximum capacity						
Stabilization Time	Within 1 second						
Operating Temperature Range	14°F to 104°F / -10°C to 40°C						
Scale Dimensions (A x B x C x D x E x F)	355 x 305 x 121.8 x 75 x 130 x 645.5 mm 14 x 12 x 4.8 x 3 x 5.1 x 25.4 in			550 x 420 x 134 x 80 x 132.9 x 842 mm 21.7 x 16.5 x 5.3 x 3.1 x 5.2 x 33.1 in		650 x 500 x 150 x 90 x 133 x 941 mm 25.6 x 19.7 x 5.9 x 3.5 x 5.2 x 37 in	
Shipping Dimensions (L x W x H)	857 x 564 x 225 mm 33.7 x 22.2 x 8.9 in			1,022 x 687 x 247 mm 40.2 x 27 x 9.7 in		1,022 x 687 x 247 mm 40.2 x 27 x 9.7 in	
Approx. Net Weight	9.6 kg / 21.3 lb			15.5 kg / 34.3 lb		25.7 kg / 56.6 lb	
Approx. Shipping Weight	12 kg / 26.5 lb			19.6 kg / 43.2 lb		29.2 kg / 64.3 lb	

Indicator

Model	i-DT33P
Construction	ABS housing, painted steel mounting bracket
Weighing Units	Kilogram, Gram, Pound, Ounce, Pound: Ounce
Application Modes	Weighing, Parts Counting, Checkweighing and Totalization
Display	6-digit, 7-segment LCD display with multi-color backlight, 45 mm / 1.8 in high digits
Check Indicator	3 color (red, green, yellow) backlight
Keyboard	4 membrane function keys
Auto-zero Tracking	Off, 0.5 d, 1 d or 3 d
Zeroing Range	2% or 100% of capacity
Interface	RS232 included, Optional second port USB Device or Ethernet
Power	100-240 VAC / 50/60 Hz Universal Power Supply or C cell battery (Not included), Optional Internal Rechargeable battery
Battery Life	Up to 360 hours (C cell battery) or 100 hours continuous use with optional rechargeable battery with backlight off
Calibration	Zero, Span or 3 point-Linear

DEFENDER® 3000 *Bench Scales*

Outline Dimensions

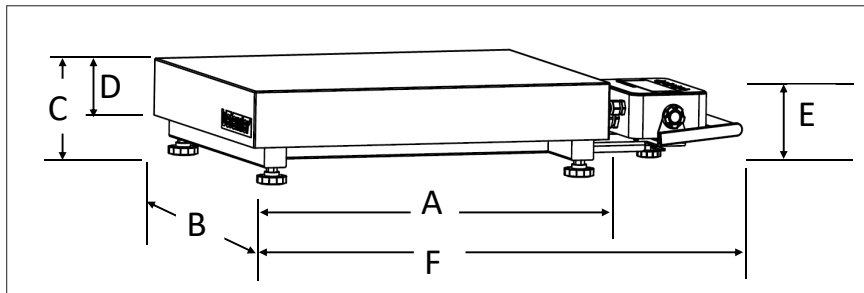
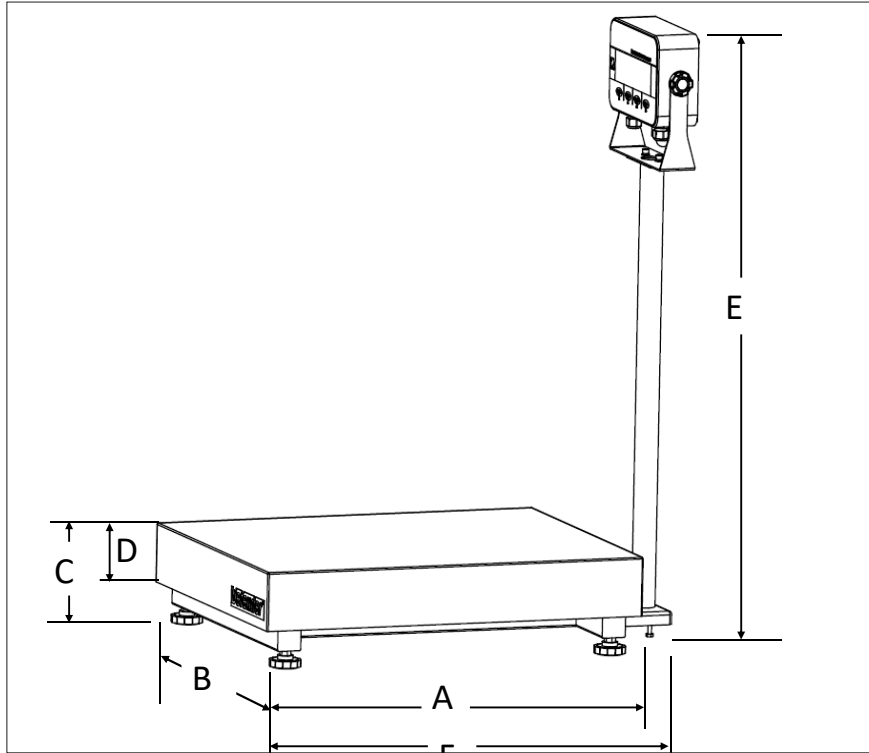

Accessories

Ethernet Kit	30429666
USB Device Kit i-DT33	30699120
Dust Cover (5) i-DT33.....	30699121
Rechargeable Battery Kit i-DT33P.....	30699122
Wheel Kit, Defender Series (Max. load: 300 kg / 600 lb)	30372146
Wheel Kit Stainless Steel Defender Series (Max load: 600 kg / 1,200 lb)	30616409
Carrying Handle Kit	
Stainless Steel i-DT33.....	30696600
SF40A Printer	30064202
Cable RS232 i-DT33P	80500525

Compliance

- **Metrology:** NTEP (Indicator: CC 21-070, Platforms: CC 21-075); Measurement Canada (Indicator: NoA AM-6183, Platforms: NoA AM-6180) Class III
- **Product Safety:** UL61010-1; CAN/CSA C22.2 61010-1; IEC/EN 61010-1
- **Electromagnetic Compatibility:** FCC Part 15 Class A; Canada ICES-003 Class A; IEC/EN 61326-1 Class B, basic environments
- **Ingress Protection:** IEC 60529 – IP54 (for indicator with optional dust cover), IEC 60529 – IP65 (for load cell)
- **Compliance Marks:** CSA, CE
- **Other:** WEEE, RoHS

80776726_A 20220505 © Copyright OHAUS Corporation

