



7000 Series

T72XW Indicator



Advanced Performance Stainless Steel Indicator with External Device Control Capabilities

The OHAUS T72XW indicator provides flexibility, performance and operation necessary for specific applications with connectivity and data output capabilities including over/under checkweighing, animal weighing and counting. The 7000 series indicator has multiple functions, intuitive software, multiple connectivity options, and the durability to stand up to the wear and tear of industrial locations.

Standard Features Include:

- **High Resolution and Multi Load Cell Support for Higher Capacity Industrial Weighing**—With a 50,000 displayed resolution and the ability to support up to 10 load cells, T72XW was designed for heavy-duty industrial applications.
- **Multiple Connectivity Interfaces Support Complex Applications**—Two available option slots enable a wide range of connectivity interfaces. Control external devices using the discrete I/O interface and transfer data through the serial, USB or Ethernet ports.
- **Advanced Applications with Intuitive Navigation**—T72XW is very easy to set up and navigate, a vivid graphic display with on-screen prompts and an alphanumeric keypad with designated keys for common functions such as Tare and ID information.
- **Customized Features Provide a User-Friendly Experience**—Helpful functions such as print templates with customization options, report view and print modes, diagnostic and maintenance modes and password protection are standard.



99 Washington Street
Melrose, MA 02176
Phone 781-665-1400
Toll Free 1-800-517-8431

7000 Series T72XW Indicator

Model	T72XW
Capacity	Up to 998000 (t, kg, g or lb)
Maximum Displayed Resolution	1:50,000
Maximum Approved Resolution	1:10,000 (NTEP, Measurement Canada); 1:6,000 (EC, OIML)
Weighing Units	kg, lb, oz, lb-oz, g, ton, t
Weighing Modes	Animal Weighing, Parts Counting, Checkweighing
Display	Transflective graphic LCD with white backlight, 240 x 96 pixels
Under/Accept/Over indicators	3 Zones, up to 25 targets
Controls	8 function, 4 navigation, 12 alpha numeric membrane switches
Ingress Protection	IP66
Load Cell Excitation Voltage	10 VDC
Load Cell Drive	Up to 10 x 350 ohm load cells
Load Cell Input Sensitivity	Up to 3 mV/V
Stabilization Time	Within 2 seconds
Auto-Zero Tracking	Off, 0.5d, 1d, 3d or 10d
Zeroing Range	+/-2% or +/-20% of capacity
Interfaces	RS232 (included), SD card (included), Ethernet (optional), USB with Discrete I/O (optional), Second RS232/RS485 (optional)
Operating Temperature Range	14 °F to 104 °F / -10 °C to 40 °C
Main Power	100-240 V ~ 0.15 A 50/60 Hz internal power supply
Housing dimensions (W x D x H)	11.1 x 3.4 x 9.1 in / 283 x 86 x 232 mm
Net weight	6.6 lb / 3 kg
Shipping weight	7.5 lb / 3.4 kg
Shipping Dimensions	13W x 9.5D x 7H in / 324W x 240D x 187H mm

Additional Features

Check weighing lights with selectable operation and audible signal settings, sealed front panel, five operating languages (English, Spanish, French, German and Italian), selectable environmental and auto-print settings, stability indicator, overload/underload indicators

Approvals

- **Metrology:** NIST Handbook 44 (NTEP CC 14-049), Measurement Canada Weights and Measures Regulations (AM-5943), (Class III, n_{max} 10,000), EN 45501 (TC8509, T5980), OIML R76-1, (R76/2006-NL 1-14.04), (Class III, n_{max} 6000)
- **Product Safety:** UL, cUL, CE
- **Electromagnetic Compatibility:** FCC Part 15 Class A, ICES-001 Class A, IEC 61326-1 (emissions Class B, immunity Industrial requirements)

Options and Accessories

Interface Options

Ethernet Kit, T72XW	30132163
USB with I/O kit, T72XW	30132164
COM2 Kit, T72XW	30132165

Mounting Accessories

Column Mount Kit, 35cm, stainless steel, T71	80500725
Column Mount Kit, 68cm, stainless steel, T71	80500726

Compatible with all existing columns for D31/D51/CKW

Dimensions

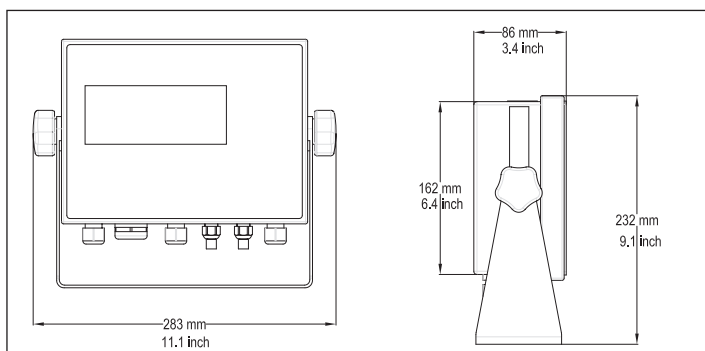

80774778 © Copyright OHAUS Corporation

