

9. Troubleshooting

Problem	Causes	Measures
No display	Power not connected. Fuse blown.	Check cord connection and power supply, Unplug and re-attach power cord. Check and replace fuse at power inlet.
Voltage or Amperage setting not reached	Maximum wattage exceeded	Resistance of the load (gel tank buffer) is too low. Change buffer concentration, or adjust Voltage to a lower value.
NO LOAD displayed	Connection wires not attached properly. Buffer is not conductive. Current flow is low due to low resistant load	Check wire connections. Check buffer concentration. Disable No Load detection if required for low resistance application.



a division of



P.O. Box 709 Edison, NJ 08818 USA
Ph: 908-769-5555 EM: info@BenchmarkScientific.com



**MYVOLT™
TOUCH**

**300V Power Supply
Operating Manual**



99 Washington Street
Melrose, MA 02176
Phone 781-665-1400
Toll Free 1-800-517-8431

Visit us at www.TestEquipmentDepot.com

This product is for research only

Version 0616-1

Contents

1. Introduction.....	1
2. Product Overview.....	2
3. Specifications.....	3
4. Installation.....	4
5. Warnings.....	5
6. Operating Guide.....	5
7. Overview of Electrical Principles.....	9
8. Maintenance.....	9
9. Troubleshooting.....	10

7. Overview of Electrical Principles

Definitions:

Voltage: The amount of potential energy between two points in a circuit

Current: The time rate of flow of an electric charge, measured in amperes.

Resistance: A material's opposition to the flow of electric current, measured in Ohms.

Power: The rate at which electric energy is transferred by an electric circuit. Electric power is expressed in units of watts, one watt is equal to one joule per second.

$$\text{Current (I)} = \frac{\text{Voltage (V)}}{\text{Resistance (R)}}$$

$$\text{Resistance (R)} = \frac{\text{Voltage (V)}}{\text{Current (I)}}$$

$$\text{Power (W)} = \text{Current (I)} \times \text{Voltage (V)}$$

8. Maintenance



Always disconnect the power cord for cleaning. When cleaning the surfaces of the instrument, use a lightly dampened cloth with mild detergent if needed. Do not use any corrosive solutions that could damage plastic.



Use caution when cleaning near the housing vents. Do not allow liquid to enter the power supply.

6.4 No Load Detection

The myVolt Touch has a No Load Detection safety feature, that will shut down the power supply if a load is not connected.

If a connected load has a high resistance (such as a single PAGE gel) and is run at a voltage at 100V or higher, the No Load fault may occur.

For this type of application, the No Load Detection can be disabled as follows:

Press MODE to select the mAMP parameter for adjustment. Press the “down” button to adjust the mAMP setting to below 5 mAMP.

“LOAD DET ON” will be displayed in a button on the bottom of the screen. Press this button to change to “LOAD DET OFF” and this will disable the No Load Detection feature.



1. Introduction

Thank you for purchasing the *Accuris myVolt Touch*™ Electrophoresis Power Supply with touch screen control.

This operating manual includes a product introduction, and important operating and safety information. Before using the power supply, please read this manual in its entirety and be sure to fully understand the features and methods for proper operation. Keep this manual for future reference.

Please check the contents when opening the box, and if there are any parts missing, damaged, or incorrect, please contact your distributor or Benchmark Scientific's Customer Service Department at 908-769-5555 or by email info@benchmarkscientific.com.

The *myVolt Touch* is a DC Power Supply for electrophoresis separations. It is designed for laboratory research applications.

The power supply has 4 sets of outputs that accept standard electrical leads with banana plugs and should only be used with electrophoresis tanks that incorporate sufficient safety features to prevent electric shock.

WARNING:

This power supply outputs high voltage and current and should be used only by experienced laboratory personnel that understand how to safely operate the instrument. Incorrect usage can present a shock or electrocution hazard.

2. Product Overview

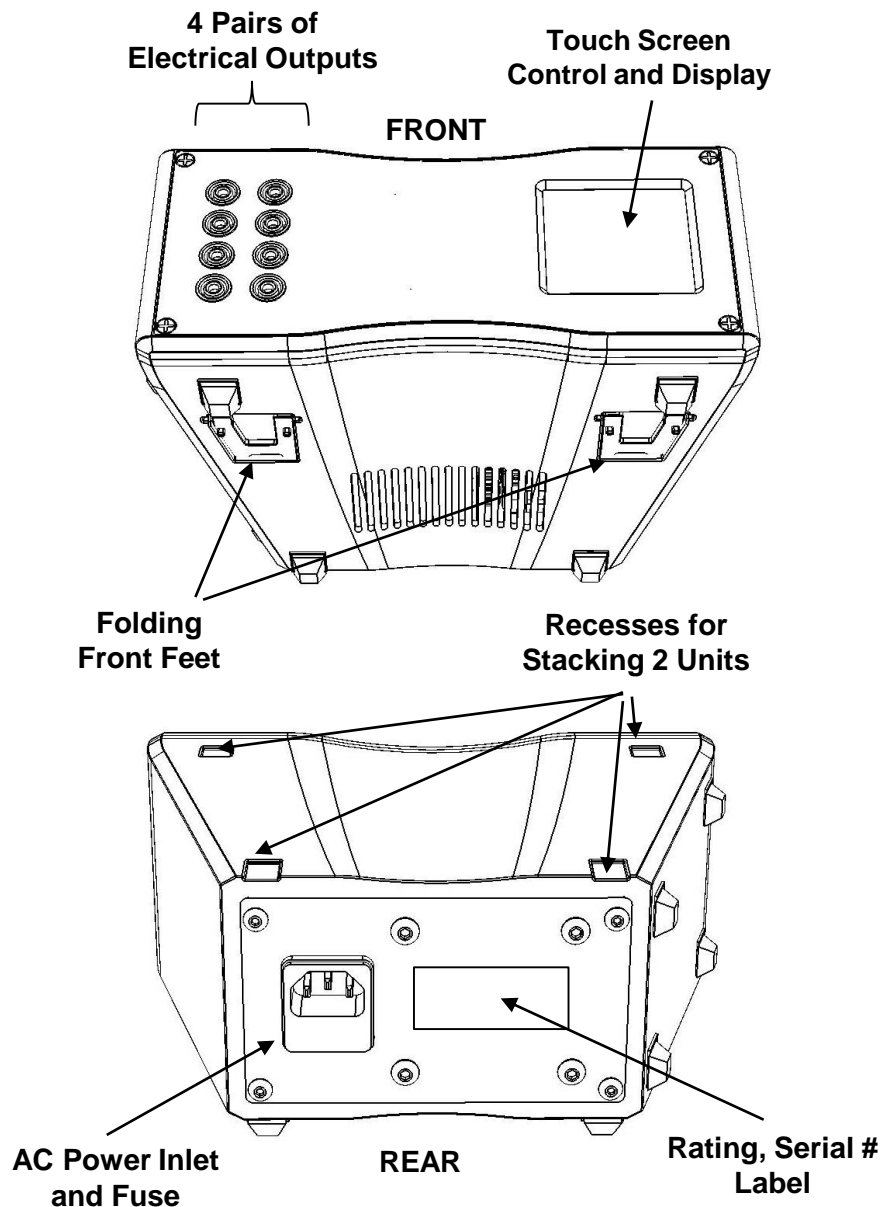

In constant amperage mode, the power supply will output the set mA current parameter, and the voltage will fluctuate relative to the resistance of the load (buffer concentration in the attached electrophoresis tanks) up to a maximum of the voltage setting that has been chosen.

6.4 Automatic Cross Over

During an electrophoresis run, the power supply will attempt to maintain the constant voltage or amperage setting, depending on which parameter is set to "CONSTANT".

If, during a run, the non-constant parameter setting (limit) is met due to the resistance of the load, the power supply will automatically "cross over" so the non-constant parameter will now be the constant and limiting parameter.

6.5 Maximum Power Limit

The myVolt Touch Power Supply has a maximum power output of 80 Watts.

$$\text{Wattage (W)} = \text{Current (I)} \times \text{Voltage (V)}$$

If the maximum power is reached during an electrophoresis run, the voltage will be limited to prevent exceeding the maximum power output.

CAUTION: It is not recommended to run the power supply at or near the maximum wattage, as this will cause the power supply and gel tank to get hot. Most electrophoresis buffer concentration will not have such low resistance that the current and voltage level will come close to the maximum power limit.

6.2 Setting Parameters

The myVolt Touch Power Supply has 3 main parameters that can be adjusted: Run Time (TIME), Voltage (VOLTAGE), and Current (mAMP).

(See section 7 for an overview of Voltage, Current, Resistance, and Power)

Press the operation MODE icon on the touch screen to change parameter mode. “TIME” will start to flash to indicate that this parameter can be adjusted. Press the UP/DOWN arrows to change the TIME value.

Pressing MODE again will toggle to the next parameter that can be set: VOLTAGE.

Adjust parameters (TIME, VOLTAGE, mAMP) as required for the electrophoresis application.

6.3 Constant Voltage / Constant Amperage

The myVolt Touch can be set to run with constant voltage or constant amperage output, with the non-constant parameter set as a limit.

Press the operation icon “CONSTANT” to switch between “CONSTANT CURRENT” and “CONSTANT VOLTAGE” running modes.

In constant voltage mode, the power supply will output the set voltage, and the mAmp current value will fluctuate depending on the resistance of the load (buffer concentration in the attached electrophoresis tanks) up to a maximum of the mAmp current setting that has been chosen.

3. Product Specifications

myVolt Touch, 300V Power Supply	
Output Voltage	5 to 300 VDC, in 5 V increments
Voltage Accuracy	+/- 2% of displayed value or 3V (whichever is greater)
Output Current	5 to 400mA, in 5 mA increments
Current Accuracy	+/- 2% of displayed value or 5mA (whichever is greater)
Maximum Power	80 Watts
Output Terminals	4 Pair, wired in parallel
Timer	1min to 9 hours, 59 minutes
Control Panel	Capacitive touch screen
Display	Backlit LCD, 128 x 128 pixel, dot matrix
Fuse	250V 2.5A, 5x20mm, Type T
Operating Temp	0 – 40° C
Humidity	0 – 60%
Dimensions	8.5x6.3x4.0in/21.5x15.5x9.75cm(W×D×H)
Net weight	3.5lbs / 1.6 kg
Input Electrical	110VAC, 50/60Hz or 230VAC, 50/60Hz
Safety	No Load Detection (can be disabled for low resistance applications). Max Power Limit.

4. Installation



Place the power supply on a smooth, level surface in an area where it will not contact liquids or chemicals.

The myVolt Power Supply features “Dual Orientation” technology, so it can be placed horizontally or vertically on the Laboratory bench. The display screen system is designed to recognize its orientation and the display will rotate automatically to be right-side-up.

Vertical Orientation

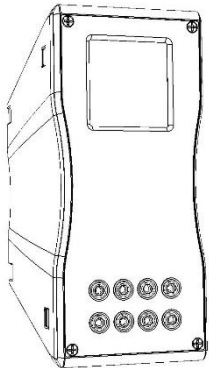

Horizontal Orientation

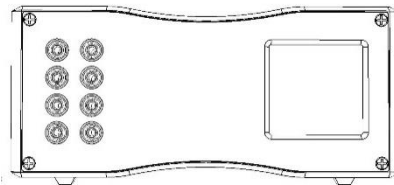

Connect one end of the included power cord to the instrument and the other end to an appropriate electrical outlet. Check the Rating/Serial # label on the rear of the power supply for the required electrical input.

5. Warnings



To avoid electrical shock, do not use this product with wet hands and ensure that all electrical leads being used are dry. Only use electrical leads that offer sufficient protective insulation and gel boxes that have appropriate safety lid systems.



Please carefully read this instruction manual before operation to avoid any personal injury. Only trained laboratory personnel should operate the system.



Do not attempt to open or repair the MyVolt Power Supply. Contact your distributor or Benchmark Scientific for service.



Always use the MyVolt Power Supply in an environment with low humidity and low dust, also keep it away from water, direct sunlight / strong light, corrosive gas, high magnetic fields, heaters, fires and other heat sources.

6. Operating guide

6.1 Touch Screen Control

