



## Wireless High Accuracy Indoor Air Quality Monitor

Your data, anytime, anywhere

- **Monitors Indoor Air Quality (IAQ)**
- **Measures:**
  - Temperature
  - Humidity
  - VOC's
  - PM1, PM2.5 and PM10
  - CO<sub>2</sub>
  - Pressure
- **Automatically uploads data to the EasyLog Cloud**
- **Coloured status ring shows IAQ level**
- **Sounder and instant notifications when IAQ is poor**
- **Detects VOCs from paints, lacquers, paint strippers, cleaning products, furnishings, glues, adhesives and alcohol**
- **Power supply included**
- **Internal back-up battery if power interrupted**



The EL-WEM+ continually monitors Indoor Air Quality, with a coloured status ring to display the IAQ level at a glance. It also automatically uploads data to the EasyLog Cloud, allowing your complete set of data measurements to be viewed, analysed and downloaded from any internet-enabled device.

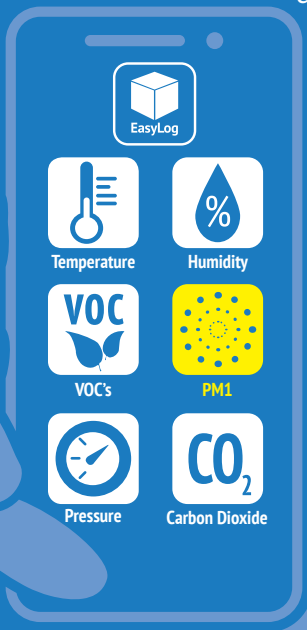

The IAQ level is rated in five levels from Excellent to Inadequate, and if it falls to Poor the sounder is activated and email and SMS notifications can be sent to your selected contacts. There is also a configurable night mode, which mutes the sounder and turns the LEDs on.

The EL-WEM+ is simple to set up, with a single button press and the EasyLog Cloud App.

A power supply is included and the unit also has an internal back-up battery, allowing it to continue operating in low power mode if mains power is temporarily lost.



The status ring indicates the current IAQ level at a glance



EasyLog

Your data, anytime, anywhere

# EL-WEM+

## Wireless High Accuracy Indoor Air Quality Monitor

### IAQ RATING INDEX

Indoor Air Quality is rated as one of five levels, ranging from Excellent down to Inadequate. This rating uses a points based system, taking measurements from five parameters. The points from each parameter are added together to give the final IAQ rating:

Parameter	Excellent 5 points	Good 4 points	Fair 3 points	Poor 2 points	Inadequate 1 point
Temperature °C	$18 \leq T \leq 21$	$17 \leq T < 18$ $21 < T \leq 22$	$16 \leq T < 17$ $22 < T \leq 23$	$15 \leq T < 16$ $23 < T \leq 24$	$T < 15$ $T > 24$
Relative Humidity %	$40 \leq RH \leq 60$	$30 \leq RH < 40$ $60 < RH \leq 70$	$20 \leq RH < 30$ $70 < RH \leq 80$	$10 \leq RH < 20$ $80 < RH \leq 90$	$RH < 10$ $RH > 90$
TVOC (index)	$TVOC < 50$	$51 \leq TVOC < 100$	$101 \leq TVOC < 150$	$151 \leq TVOC < 200$	$TVOC \geq 201$
PM10 $\mu\text{g}/\text{m}^3$	$PM < 33$	$33 \leq PM < 58$	$58 \leq PM < 75$	$75 \leq PM < 91$	$PM \geq 91$
CO <sub>2</sub> ppm	$CO_2 < 600$	$600 \leq CO_2 < 800$	$800 \leq CO_2 < 1500$	$1500 \leq CO_2 < 1800$	$CO_2 \geq 1800$
IAQ Rating	$\geq 23$ points	$\geq 20$ points	$\geq 15$ points	$\geq 10$ points	$< 10$ points

### CONNECTING TO THE CLOUD



1

Plug in the power supply, then press the central button to turn the device on.



2

Download and login to the EasyLog Cloud App on your mobile device. Select "Setup Device" and follow the on-screen instructions to add your EL-WEM+.



3

You can now view the EL-WEM+'s data and change settings either in the EasyLog Cloud App or by visiting your account at: [www.easylogcloud.com](http://www.easylogcloud.com)



EasyLog

Your data, anytime, anywhere

EL-WEM+

Wireless High Accuracy Indoor Air Quality Monitor

# EasyLog Cloud *Your Data: Anytime. Anywhere.*



Easily access your most important data, anywhere



Connect data loggers from multiple sites in one account



Automatic emails alerts and SMS



Remotely manage all of your data logger devices



Graph, review and analyse your data



Audits are easy with our event log system



Secure Cloud storage



Configurable user profiles

## EasyLog Cloud App

Available for Android and Apple devices, the EasyLog Cloud app enables you to monitor and manage your wireless sensors on the go.

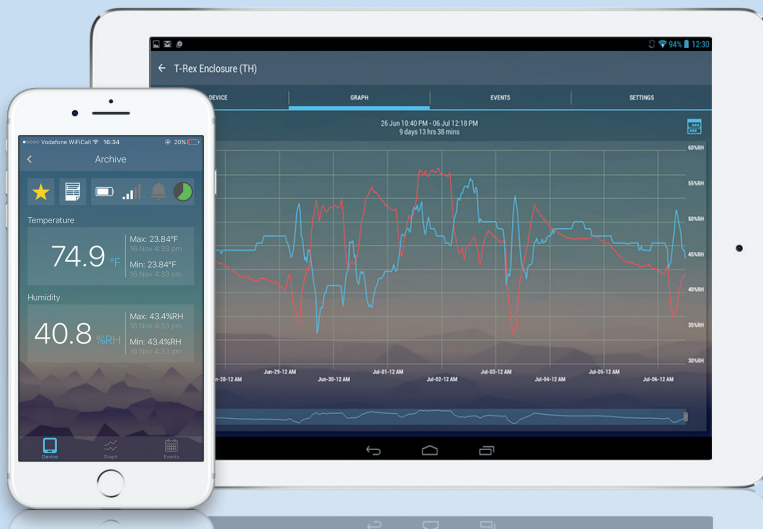

Access your vital data from any internet-enabled computer, tablet or mobile device with EasyLog Cloud. From single locations to worldwide operations, the system is perfectly scalable and can run through your existing wireless networks.

Critical events are notified to specific users in seconds via an alarm system that's easily tailored to your exact requirements.

Data is accessible 24/7 and powerful online tools make it simpler than ever to view, compare and analyse readings. An audit trail is automatically created that includes both system and data events.

Starter and Professional accounts are available, always flexible and with no locked-in contracts.



EasyLog

Your data, anytime, anywhere

# EL-WEM+

## Wireless High Accuracy Indoor Air Quality Monitor

### INCLUDED IN THE BOX



EL-WEM+



PSU  
Power supply



3 x ADAPTORS



CABLE  
Power cable

### ALSO IN THE RANGE

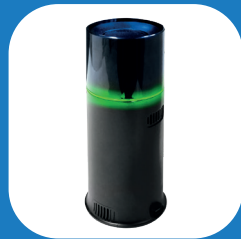

EL-WEM

### DIMENSIONS

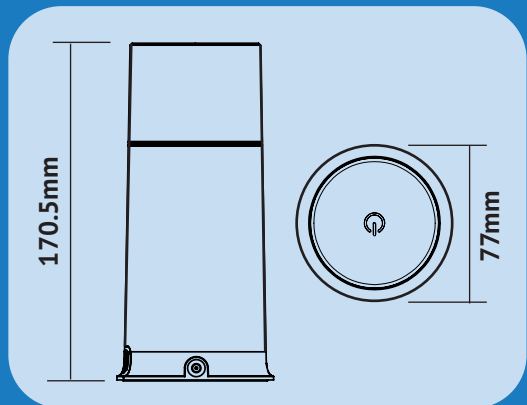

### SPECIFICATIONS



#### Temperature

Measurement Range -20 to +60°C

Measurement Accuracy ±0.6°C at 15°C

#### Humidity

Measurement Range 0 to 95%RH

Measurement Accuracy ±3%

#### Volatile Organic Compounds (VOC)

Biogenic VOC Accuracy ±5%

#### Particulate Matter (PM)

Particle Size Measured PM10, PM2.5 and PM1

Measurement Range 0 to 1000µg/m³

#### Carbon Dioxide (CO<sub>2</sub>)

Measurement Range 0 to 40,000ppm

Measurement Accuracy ±3%

#### Pressure

Measurement Range 300 to 1100mbar

Measurement Accuracy ±0.6mbar

#### Dimensions

Height x Diameter 170.5 x 77mm



Visit [lascarelectronics.com/data-loggers](http://lascarelectronics.com/data-loggers) to see our full range of data loggers and measuring devices