



# Explorer<sup>®</sup>

Analytical, Precision, and High Capacity Balances

**Test Equipment  
Depot**  
1-800-517-8431

99 Washington Street  
Melrose, MA 02176  
Phone 781-665-1400  
Toll Free 1-800-517-8431

Visit us at [www.TestEquipmentDepot.com](http://www.TestEquipmentDepot.com)



## *Intelligent. Intuitive. Ingeniously Practical.*

The OHAUS Explorer<sup>®</sup> Series has risen to the next level of ingenuity—expanding on its modern features and design to offer unmatched functionality in a line of high-performance balances unlike any other on the market.

### *Standard Features Include:*

- **Intelligent PERFORMANCE**—All Explorers have newly optimized linearity and repeatability specifications and enhanced vibration filtering for better balance stability. Select models feature OHAUS' automatic internal calibration system that performs routine maintenance by calibrating the balance daily. 3×3 filtering setup ensures fast and stable weighing results. The Explorer EX.../E models additionally offer traditional external calibration. These combined enhancements improve accuracy, efficiency, and throughput.
- **Intuitive OPERATION**—A large color touch-screen display, icon-driven application software that features 14 unique application modes, and a 3 level adjustable angle display make Explorer the easiest to use, most advanced balance in its class today.
- **Ingenious DESIGN**—The base and display separate for maximum flexibility in any work area. Draftshield models isolate the weighing chamber to enhance stability and speed results while offering maximum accessibility to the weighing chamber through top-mounted side doors or through the versatile top door that flips or slides open. Hands-free entry is available with optional automated side doors.
- **Practical Features**—Explorer has up to four user-programmable touchless sensors to minimize cross contamination and wear and tear normally associated with repeated touching of the balance. The OHAUS Explorer EX...N series of balances meet or exceed the Class I or II accuracy requirements in accordance with NIST Handbook 44 and Canada's Weights and Measures Regulations.

# Explorer<sup>®</sup> Analytical, Precision, High Capacity

## Intelligent PERFORMANCE

With stabilization times up to 50% faster and superior shock protection, Explorer delivers fast, accurate, and reliable results.

- **Fast stabilization time**
  - Improves operational efficiency
  - Increases throughput
  - Improves productivity
- **Optimized linearity and repeatability specifications**
  - Provides accurate and repeatable results
- **Optimized vibration filtering**
  - Provides balance stability in unstable environments
- **Superior Shock, Spill and Splash Resistance**
  - 2-D Protection guards balance against disruptions in service due to shock or sudden movements. IP54 base enclosure protects the weighing base from damage by debris and accidental spills and splashes.\*

*\*High Capacity Models Only*



## Intuitive SOFTWARE

SmarText™ 2.0 is OHAUS' easy-to-use graphical software featuring 14 applications, virtual QWERTY and numeric keypads, and below-minimum weight indication.

- **Color VGA display with icons for simple menu navigation**
  - High resolution, 5.7" (145mm) diagonal color 640 × 480 pixel display reproduces highly readable operating software
  - Resistive touch screen display quickly responds to operator's touch or stylus
- **14 built-in applications with customization capabilities to meet the varying needs in laboratory and industrial settings**
- **Minimum Weight capability with visual warning feature**
- **Virtual QWERTY keyboard and numeric keypad to quickly input GLP and GMP data and other application data, direct scan of the sample ID to the input field with an optional barcode reader.**
- **Password protected User Manager with administrator capability**
- **Library function to store and recall customized applications including 10 recipes for Formulation application.**
- **Alternate RS232 command feature adapts the balance to existing data acquisition software**
- **External input for zero, tare or print operations via the external foot switch accessory**
- **Audible and visual feedback for touch screen input commands as well as the indication of the check weighing status**

*\*13 application modes on Explorer High Capacity models*



## Ingenious DRAFTSHIELD

Explorer's draftshield provides ample access and visibility to the weighing chamber through the versatile top door and side sliding doors. Select models feature motorized side doors that open and close automatically with use of the touchless sensors on the base and display.

- The automatic draftshield door models have a new function for automatically opening draftshield doors without touching the balance. It helps to eliminate sample residue transfer and contaminations.
- Side doors seamlessly glide on top-mounted bearings
- The versatile top door offers two entry options; access the weighing chamber by flipping the top door or sliding the glass panel open.
- The expansive side entry 6.3" × 9.4" (160 mm × 240 mm) allows you to freely place and remove large weigh boats or other large vessels in the weighing chamber
- Antistatic coated glass helps dissipate static charges in the weighing chamber which could adversely affect the weighing results
- Easy to install and remove glass panels and a stainless steel bottom make Explorer extremely easy to clean
- A draftshield chamber light is available when the balance is used in low lighting environments



## Practical TOUCHLESS SENSORS

Explorer features up to four touchless sensors for hands-free operation of zero, print, calibration, tare, automated draftshield doors and other selectable functions

- **Hands-free operation**
  - Improves weighing efficiency
  - Eliminates sample residue transfer
  - Minimizes contamination
- Two sensors on the base\* and two on the display can be set up individually to allow for remote operations
- The sensors can be set up to provide automated operation of the draftshield side doors and can be programmed to automatically open the opposite side door in order to support efficient and logical sample placement with your free hand.



*\*Analytical and precision models only.*

*Automatic Draftshield door operation only offered on Analytical models*

# Explorer<sup>®</sup> Analytical, Precision, High Capacity

## Intelligent CALIBRATION

AutoCal™ ensures performance and assists with routine maintenance by automatically calibrating the balance daily.

- Self-calibrates the system when it senses a temperature change sufficient enough to affect weighing accuracy, or every 3-11 hours, depending on the user configuration
- Performs routine calibration and reduces the need for external masses
- External Calibration Models Available—  
All models feature traditional external calibration in which external weights (user's choice of calibration weight values) are required to calibrate the balance to ensure accuracy

## Intuitive USER SETUP

Explorer is the industry's most easy-to-use balance, featuring leveling assistance and instructional messaging for quick out-of-the-box setup and use.

- Easy to view illuminated level indicator placed at the front of the balance
- Adjustable thumbwheels are easy to turn to level the balance
- Level assist screen helps users quickly identify which thumbwheels need to be adjusted to level the balance
- Data Transfer Function helps to output data directly into Microsoft Excel
- Instructional messaging during application use guides users through the weighing process
- User information menu allows users quickly view and learn more about the available balances features
- Up to 14 operating languages make Explorer's Intuitive User Setup truly universal



## Dimensions

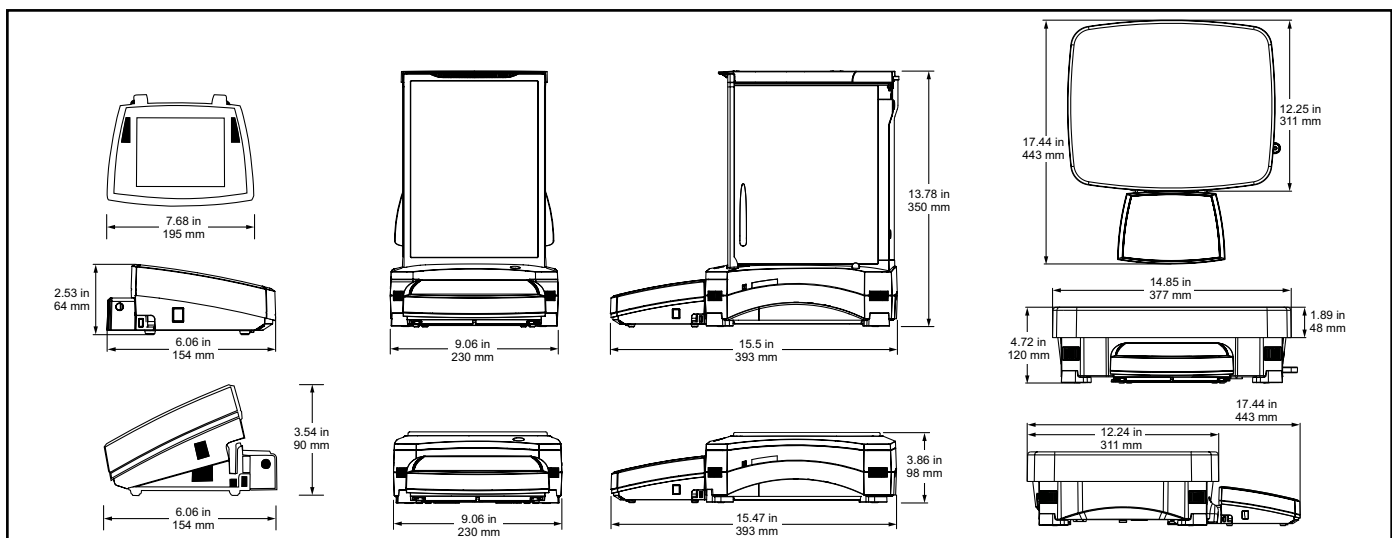



## Ingenious MODULAR DESIGN

Explorer's modular design features a color touch display that can be separated from the weighing base

- **Display features:**

- 3 position, angular adjustment to optimize viewing
- Easy access communication ports include standard USB and RS232 and an optional third port for either RS232 or Ethernet
- Left and right side cable exit feature for customized installation capability
- Tower and wall mount ready for modular installation\*
- In-use cover for protection against rugged use
- Extension cable accessory extends remote use up to 27 feet (9 meters)



- **Base features**

- Quadrastance™ design with four adjustable thumbwheels provides superior stability
- Robust die-cast metal bottom housing
- Accessory tower mount ready for modular installation
- Cable storage system underneath base keeps excess cables manageable



- **Adjustable rolling feet accessory allows for simple and quick movement and relocation of the balance\*\***

*\*Tower mount sold separately*

*\*\*High capacity models only*

## Practical APPROVALS

Explorer EX...N series of balances meet or exceed the Class I or II accuracy requirements in accordance with NIST Handbook 44 and Canada's Weights and Measures Regulations. Certificate of Conformance Number 12-012 was issued under the National Type Evaluation Program (NTEP) of the National Conference on Weights and Measures. Notice of Approval AM-5847 was issued by Measurement Canada, an Agency of Industry Canada.

## Other Standard Features & Equipment:

Menu lock switch, security bracket, integral weigh below hook for below balance weighing applications, removable stainless steel weighing pan, stability indicator, overload and underload indicators, auto standby.



# Explorer<sup>®</sup> Application Software

The OHAUS Explorer's advanced applications simplify even the most complex laboratory measurements. Whether it's determining the difference between initial and residual weights or calculating the density of solids and liquids,

Explorer eliminates the need for time consuming manual calculations and data logging. The high resolution display and innovative user interface make balance setup and application use effortless.

Displays your current application. One-touch drop down menu shows additional application choices

Touch to change your application settings

Quickly store and recall your library data of regularly used items

Need help? Just tap the Info button for built-in assistance

Easy-to-follow text prompts tell you what to do next

Large weigh results can be viewed at any angle

Results area shows pertinent application information (varies by application)

Seven quick keys make balance operation a breeze!

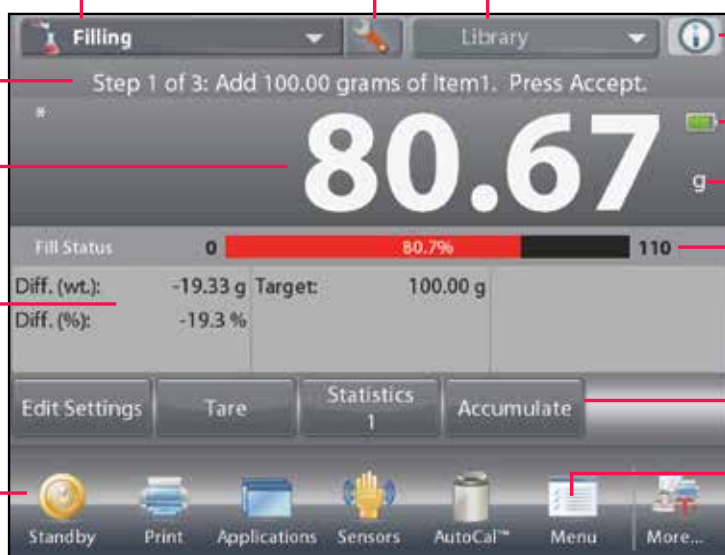

Battery life indicator when powered by optional battery pack (for High Capacity models only)

Press the weighing unit to change the unit of measure (activate in Weighing Units menu)

Fill and capacity bar indicators assure you are always in range (indicators vary by application)

Soft keys are application specific

Press Menu to choose applications, change user settings, balance setup and much more!

## Standard Apps



### Weighing

Determine weight of items in the selected unit of measure. Minimum Weight feature is also available.



### Percent Weighing

Measure the weight of a sample displayed as a percentage of a pre-established Reference Weight.



### Dynamic Weighing

Weigh an unstable load. Balance takes an average of weights over a time period.



### Totalization

Measure cumulative weight of multiple items. Cumulative total may exceed balance capacity.



### Differential Weighing

Store sample weights and calculate the difference between initial weights and final weights.



### Peak Hold

Capture and store highest weight in a series. Both stable and unstable weights are captured.



### Parts Counting

Count samples of uniform weight. Choose Standard Counting, Check Counting, or Fill Counting.



### Pipette Adjustment

Check pipette values by weight analysis, with built-in water density table. (Non High Capacity Models)



### Check Weighing

Compare the weight of a sample against target limits. Choose from Standard, Nominal-weight, or Nominal-Percent.



### Filling

Fill a container to a target weight. Progress bar displays filling status.



### Formulation

For compounding and recipe making. The number of components can be from two to 99.



### Density Determination

Determine density of solids more dense than water, solids less dense than water, liquids, or porous material.



### Ingredient Costing

Determine cost of formula or recipe based on known cost/quantity of components or ingredients.



### SQC

Monitor and/or control processes to eliminate under and over filling.

# Explorer<sup>®</sup> High Capacity

The Explorer series includes three high-capacity precision models with capacities up to 35 kg. Explorer high-capacity balances offer the same intuitive features, such as AutoCal™ and a 1 second stabilization time, with additional functions and attributes to support higher capacity weighing applications.

## Modular Design

- 5.7" (145mm) diagonal color VGA touch screen optimizes viewing and menu navigation
- Two touchless sensors on display offer hands-free operation
- The display can be separated from the base up to 5 feet (1.5 meters) in order to fit operational needs in almost any workspace. A 27 foot (9 meter) cable is also available when additional flexibility is needed.

## Superior protection in rugged or unstable environments

- With a die-cast metal base and a 14.8" × 12.2" (377 × 311mm) stainless steel pan, the Explorer High Capacity is built to withstand rugged, every day use.
- 2-D Protection prevents shock and damage associated with movement and forces applied to the balance
- IP54 base enclosure protects the weighing base from damage by debris and accidental spills and splashes. (High Capacity models only)

## High Capacity Accessories for Added Efficiency

- Adjustable rolling feet option provides assistance to easily moving the balance
- Rechargeable battery option provides 10 hours of operation away from a power source
- Weigh-below hook included and can be used for density determination



*Shown with optional tower mount and rolling feet*

Model	EX12001	EX24001	EX35001
Capacity (g)	12000	24000	35000
Readability (g)	0.1	0.1	0.1
Repeatability std (g)	±0.1	±0.1	±0.1
Linearity (g)	±0.2	±0.2	±0.2
Stabilization Time	≤1	≤1	≤1
Sensitivity Draft (PPM/°C)	3	3	3
Weighing Applications	Weighing, Percent Weighing, Parts Counting, Check Weighing, Dynamic/Animal Weighing, Filling, Totalization, Formulation, Differential Weighing, Density Determination, Peak Hold, Ingredient Costing, SQC		
Weighing Units	g, kg, ct, gn, lb, oz, ozt, N, dwt, hkt, sgt, twt, mom, tical, msg, tola, Custom Unit 1, Custom Unit 2, Custom Unit 3		
Pan Size	14.84 × 12.24 in / 377 × 311 mm		
Calibration	AutoCal™ internal calibration		
Tare Range	To capacity by subtraction		
Power Requirement	Power Input 100-240 VAC, 0.5-0.25A, 47-63 Hz, Power Output: 24 VDC, 0.63 A, 15W		
Display Type	Full-color VGA graphic display, 4-wire resistive touch screen		
Display Size	5.7 in / 145 mm (diagonal)		
Display Housing (W × H × D)	7.68 × 3.54 × 6.06 in / 195 × 90 × 154 mm		
Base Housing (W × H × D)	14.84 × 4.72 × 17.44 in / 377 × 120 × 443 mm		
Communication	Standard RS232, USB, Optional Ethernet or 2 <sup>nd</sup> RS232		
Operating Temperature Range	50°F to 86°F / 10°C to 30°C		
Operating Humidity Range	80% max up to 86°F/30°C, decreasing linearly to 50% at 104°F/40°C, non-condensing		
Storage Conditions	14°F/-10°C to 140°F/60°C at 10% to 90% relative humidity, non-condensing		
Net Weight	22 lbs / 10 kg		
Shipping Weight	25.8 lbs / 12.5 kg		
Shipping Dimensions	26.18 × 20.67 × 13.00 in / 665 × 525 × 330 mm		

# Explorer<sup>®</sup> Analytical and Precision Balances

Model	EX124	EX224	EX324	EX223	EX423	EX623	EX1103	EX2202	EX4202	EX6202	EX10202	EX6201	EX10201	
Automatic Door	EX124/AD	EX224/AD	EX324/AD	—	—	—	—	—	—	—	—	—	—	
External Calibration	—	—	—	EX223/E	EX423/E	—	—	EX2202/E	EX4202/E	EX6202/E	—	EX6201/E	—	
Certified Models	EX124N/AD	EX224N EX224N/AD	EX324N EX324N/AD	—	EX423N	—	EX1103N	—	EX4202N	—	EX10202N	—	EX10201N	
Capacity (g)	120	220	320	220	420	620	1100	2200	4200	6200	10200	6200	10200	
Readability d (g)	0.0001			0.001			0.01			0.1			0.1	
Verification Interval* e (g)	0.001			—	0.01	—	0.01	—	0.1	—	0.1	—	0.1	
Class*	I			—	II	—	I	—	II	—	I	—	I	
Repeatability std (g)	±0.0001			±0.001			±0.01			±0.1			±0.1	
Linearity (g)	±0.0002			±0.002			±0.02			±0.2			±0.2	
Stabilization Time (sec)	≤2		≤3	≤1.5			≤1			≤1			≤1	
Sensitivity Drift (ppm/°C)	1.5			3			3			5			3	
Weighing Units	Gram, Milligram, Kilogram, Carat, Ounce, Ounce Troy, Pound, Newton, Momme, Mesghal, Hong Kong Tael, Singapore Tael, Taiwan Tael, Tical, Tola, Baht, Custom Unit 1, Custom Unit 2, Custom Unit 3													
Weighing Units, Certified Models	mg, g, oz, lb, ct, ozt, grain, dwt			—	mg, g, oz, lb, ct, ozt, grain, dwt	—	mg, g, oz, lb, ct, ozt, grain, dwt	—	g, kg, oz, lb, ct, ozt, grain, dwt	—	g, kg, oz, lb, ct, ozt, grain, dwt	—	g, kg, oz, lb, ct, ozt, grain, dwt	
Weighing Applications	Weighing, Percent Weighing, Parts Counting, Check Weighing, Dynamic/Animal Weighing, Filling, Totalization, Formulation, Differential Weighing, Density Determination, Peak Hold, Ingredient Costing, Pipette Adjustment, SQC													
Pan Size	Ø 3.54 in / 90 mm			Ø 5.12 in / 130 mm				7.48 x 7.87 in / 190 x 200 mm						
Calibration	All models feature external calibration. Models feature AutoCal™ internal calibration, except for EX.../E models													
Tare Range	To capacity by subtraction													
Power Requirements	AC Adapter Input: 100-240 VAC, 0.6A, 50-60 Hz													
Display Type	Full-color VGA graphic display, 4-wire resistive touch screen													
Display Size	5.7 in / 145 mm (diagonal)													
Display Housing (WxHxD)	7.68 x 3.54 x 6.06 in / 195 x 90 x 154 mm													
Base Housing (WxHxD)	9.06 x 13.78 x 15.47 in / 230 x 350 x 393 mm						9.06 x 3.86 x 15.47 in / 230 x 98 x 393 mm							
Communication	RS232, USB and optional ethernet or 2 <sup>nd</sup> RS232													
Temperature Range	50°F to 86°F / 10°C to 30°C													
Humidity Range	80% max up to 86°F/30°C decreasing linearly to 50% at 104°F/40°C, non-condensing													
Storage Conditions	140°F/60°C at 10% to 90% relative humidity, non-condensing													
Net Weight	15 lbs / 6.9 kg						10 lbs / 4.3 kg			11 lbs / 5 kg				
Shipping Weight	21 lbs / 9.6 kg						15 lbs / 6.8 kg			16 lbs / 7.4 kg				
Shipping Dimensions	21.65 x 15.16 x 21.69 in / 55 x 38.5 x 55.1 cm						21.65 x 15.16 x 11.45 in / 55 x 38.5 x 29.1 cm							

For specifications related to the Unites States Pharmacopoeia (USP) minimum weight standard visit [www.Ohaus.com/USPMinWeight](http://www.Ohaus.com/USPMinWeight)

## Compliance

- **Metrology:** NIST Handbook 44 (NTEP CC 12-012), Measurement Canada Weights and Measures Regulations (AM-5847) (Class I, nmax 320000; Class II, nmax 42000; certified models only)
- **Product Safety:** IEC/EN 61010-1:2010; CAN/CSA-C22.2 No. 61010-1-12; UL Std. No. 61010-1 (3rd Edition)
- **Electromagnetic Compatibility:** IEC 61326-1; EN 61326-1:2006 (Class B); C-Tick; FCC Part 15 (Class A); ICES-003 (Class A)
- **Environment:** RoHS; WEEE

## Accessories

Density Determination Kit .....80253384  
 Sinkers glass for Density Determination Kit ... .83034024  
 Full-featured Impact Printer SF40A .....30064202  
 SF40A Paper roll (57,5mm 2pcs) .....12120799  
 SF40A Ink ribbon cassette .....12120798  
 ION-100A – Ionizer .....30130302  
 RS232 Cable, PC 9 Pin .....00410024  
 Cable, USB A to Mini USB, 1.8m Black .....28120263  
 Cable, USB-RS232 Converter .....30268619  
 Ethernet Kit .....83021082  
 Tower Mount for Display (non High Capacity models) ..  
 .....83021102  
 Tower Mount for Display\*\* .....30078082

Display Extension Cable (9 Meter / 27 Feet) ...30078078  
 Display Extension Cable (2 Meter / 6.56 Feet) .83021083  
 Draftshield Kit (0.01g, 0.1g) (non High Capacity models)  
 .....83021084  
 Security Device (Cable & Lock) .....80850000  
 Security Device (Laptop Lock) .....80850043  
 Foot Switch Kit .....83021086  
 Rolling Feet Kit\*\* .....30041470  
 Rechargeable Battery Pack\*\* .....30041295  
 Auxiliary Display PAD7 .....80251396  
 Terminal in-use cover .....83033633  
 Dust cover .....30093334

\*Certified models only \*\*High Capacity models only



99 Washington Street  
 Melrose, MA 02176  
 Phone 781-665-1400  
 Toll Free 1-800-517-8431

Visit us at [www.TestEquipmentDepot.com](http://www.TestEquipmentDepot.com)

80774580\_I 20170907 © Copyright OHAUS Corporation

With offices throughout  
 Europe, Asia, and  
 Latin America

**\*ISO 9001:2008**  
 Registered Quality  
 Management System

