

FGS-250W Manual Hand Wheel Test Stand

Operation Manual



The rated load of the test stand is 250 lb (125 kg). The maximum displacement is 9" (230 mm) without optional tensile tester. Do not overload or damage to the test stand can occur.

CAUTION

Do not use the test stand in water or oil or allow any liquids to get into the moving mechanisms of the stand. Improper operation and malfunction will result.

Do not disassemble, repair or alter the test stand. Warranty will be voided and damage may result.

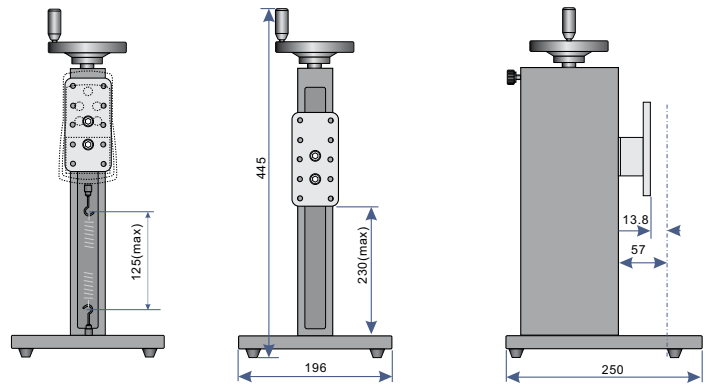

HORIZONTAL

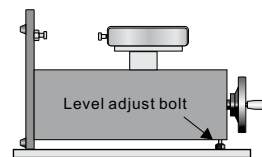

The FGS-250W Manual Hand Wheel Operated Test Stand is specifically designed for tensile and compressive force testing and destructive or failure testing for research applications in a multitude of industries.

The FGS-250W movement is created from a trapezoidal screw drive with integral nut. Combined with its top-mounted wheel that smoothly turns with minimal effort, fine, stable resolution is achieved during operation.

The FGS-250W offers dual functionality by being able to be used in either the vertical or horizontal positions with no added equipment required. Simply lay unit on its back and level with the adjustment screw and you now can run horizontal tests.

Optional accessories include a Digital Scale and a Tensile Frame adapter kit which enables extended clearance for tensile tests.

SPECIFICATIONS

Capacity: Up to 250 lbf (125 kg); 143 lbf (65 kg) with optional Tensile frame.

Travel: 0.12" (3 mm)/turn

Stroke: 9" (230 mm) max.; 10.24" (260 mm) max. with Tensile Frame kit.

Dimension: 9.8 x 7.7 x 17.5" (250 x 196 x 445 mm)

Weight: 15.4 lb (7 kg)

Warranty: 1 year

Packing List: Test Stand (1), Handle in Hand Wheel (1), Adapter Screw (M6) (1), Screw M4 x 16 (for force gauge) (6)

HANDLE

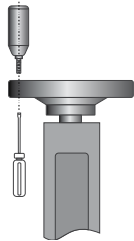

FORCE GAUGE

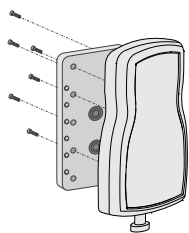

GAUGE MOUNTING PLATE

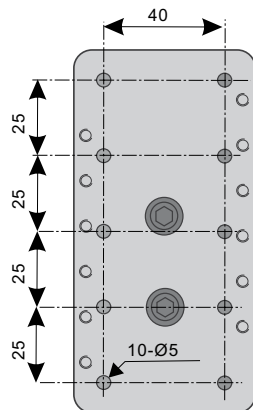

BASE PLATE

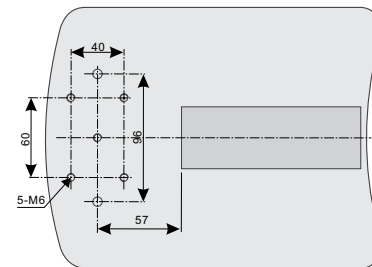

FIXTURE ATTACHMENT MOUNTING

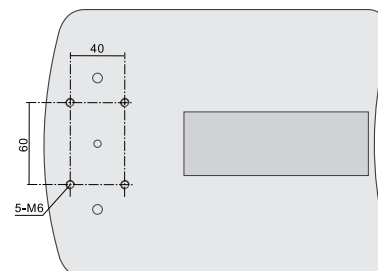

99 Washington Street
Melrose, MA 02176
Phone 781-665-1400
Toll Free 1-800-517-8431

INSTALLATION FOR OPTIONAL TENSILE FRAME

FGS-250W-TFK

Capacity: 143 lbf (65 kg)

Dimensions: 4.4 x 0.55 x 17" (112 x 14 x 433 mm)

Packing List: Tensile Frame (1), Screw M6 x 25 (3), Hook (1)

INSTALLATION FOR OPTIONAL DIGITAL SCALE

FGS-250W-DSK

Measure Range: 7.87" (200 mm)

Resolution: 0.0005" (0.01 mm)

Repeatability: 0.0004" (0.01 mm)

Power Supply: Button cell SR44 1.55 V

Work Conditions: 32 to 104°F (0-40°C), <80% RH

Packing List: Digital Scale (1), Joint Plate (1), Mounts (1), Screw M3 x 5 (3), Screw M4 x 16 (2)

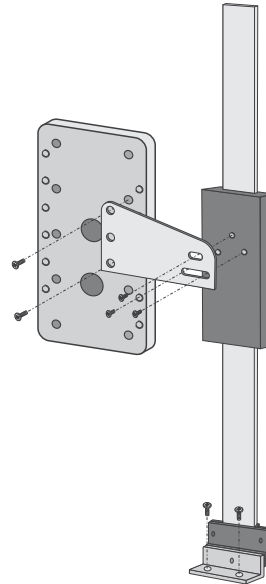
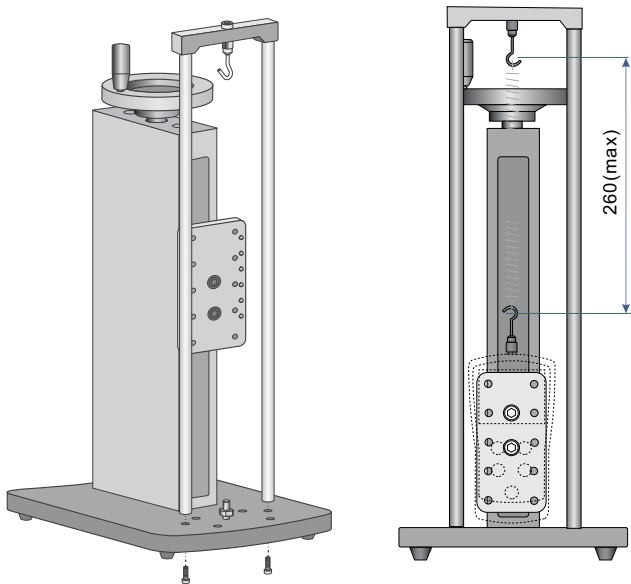

TENSILE FRAME KIT MOUNTING

