

FM260

Formaldehyde (HCHO or CH₂O) and Total Volatile Organic Compounds (TVOC) Tester



Introduction

Thank you for selecting the Triplet FM260. The FM260 measures HCHO (formaldehyde) and TVOC (Total Volatile Organic Compounds).

Potential sources for TVOCs include paints, finishes, adhesives, cigarette smoke, pesticides, personal care products, car exhaust, new furnishings, wall coverings, household cleansers, and cooking fuels. Chemicals include: Acetone, Ethylene Glycol, Formaldehyde, Xylene, 1,3-butadiene, Tetrachloroethene, Hydrogen Sulfide, Ammonia, Toluene, Benzene, Methylene Chloride, Perchloroethylene, and MTBE.

Features

- Fuel Cell Formaldehyde Sensor Technology
- High accuracy measurements
- Backlit LCD display
- Real-time display of HCHO (formaldehyde) concentration in air
- Real-time display of TVOC (Total Volatile Organic Compounds) concentration in air
- Two unit selections (PPM, mg/m³)
- Audio-visual High and Low Alarms for HCHO
- Auto power off

Description

METER DESCRIPTION

1. HCHO sensor (front)
2. AC Adaptor jack (under flap)
3. Down arrow and Alarm Setup button
4. Battery compartment (rear)
5. ON-OFF button (also used in Alarm Setup)
6. Up arrow and UNIT selection button
7. Backlit Display
8. TVOC sensor (rear)

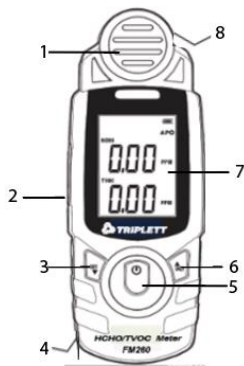

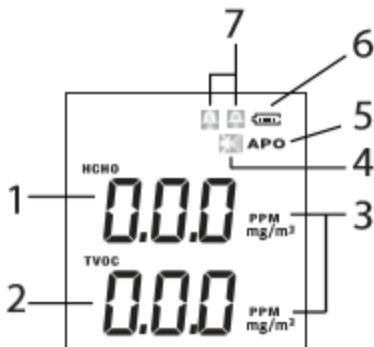

LCD DISPLAY

1. HCHO reading
2. TVOC reading
3. Selectable units of measure
4. Alarm Beeper symbol
5. Auto Power OFF reminder
6. Rechargeable Battery status
7. High and Low Alarm symbols



Operation

POWER THE METER

Press the  button to turn on the meter. The battery symbol informs the user as to the battery strength. Connect the battery charger to recharge the battery. Long press the  button to power off. The LCD will count down: 3, 2, 1, then OFF before switching off.

AUTO POWER OFF

The meter will switch off after 30 minutes of inactivity. Press any function button to prevent the meter from powering off; the auto power off timer will be then be reset. The APO display symbol reminds the user that Auto Power OFF is always active.

GENERAL USE

All LCD display lines will switch ON when power is applied to the meter. The bottom TVOC display will count down from 10 seconds or from 90 seconds (depending on the environment) to zero. When countdown is complete the meter is ready for use.

In normal mode, the top display indicates the HCHO concentration in PPM or mg/m³. The bottom display indicates the TVOC concentration in PPM or mg/m³.

Use the **UNIT** button to switch units between PPM and mg/m³.

With the meter on, if the measured HCHO concentration exceeds the high or low user- programmable Alarm thresholds, the LED display will flash red in color and the audible beeper will sound (unless it has been disabled with the **SET/▼** button). Press **SET/▼** to silence the alarm beeper (when it is sounding) or to disable the beeper entirely. When disabled, the displayed beeper symbol is switched off.

ALARM SETUP (HCHO only)

Low Alarm Setup

1. Long press the **SET/▼** button to enter the setup mode.
2. The low alarm icon will display and the LCD will show the low alarm threshold.
3. Use the **▲** and **▼** buttons to adjust the low alarm threshold.
4. Press the **⏸** button to go to the high alarm setup screen.

High Alarm Setup

1. Use the **▲** and **▼** buttons to adjust the high alarm threshold.
2. Press the **⏸** button to return to the normal measurement mode.

CONTROL BUTTONS

1. Short press the **▼SET** button to silence the beeper (when it is sounding) or to disable/enable the alarm beeper. This button is also used as a down arrow to change the high and low Alarm threshold values in the Alarm Setup mode.
2. Long press the **▼SET** button to enter the Alarm Setup Mode (See Alarm Setup section).
3. Short press the **▲UNIT** button to change the unit of measure (PPM or mg/m³) or to use it as an up arrow to set the alarm threshold values in the Alarm Setup mode.

SAFETY

Do not store or use the instrument in an environment where corrosive gas is present. Do not obstruct the sensors when in use.

Use only the supplied lithium-ion battery to power the meter.

Use only the supplied AC adapter/battery charger to charge the lithium-ion battery.

BATTERY CHARGE and REPLACEMENT

1. When the battery requires charging, plug the supplied battery charger into the meter (left side, under flap) and to a source of AC power. A full charge requires 2 hours.
2. To replace the battery, open the rear battery compartment and replace the Polymer lithium-ion battery (7.4V 1300mAh). Re-assemble the meter before use.

Battery Safety Notes: Please dispose of batteries responsibly; never dispose of batteries in a fire, batteries may explode or leak. If the meter is not to be used for 60 days or more, remove the battery and store separately.



Never dispose of used batteries or rechargeable batteries in household waste.

As consumers, users are legally required to take used batteries to appropriate collection sites, the retail store where the batteries were purchased, or wherever batteries are sold.

Disposal: Do not dispose of this instrument in household waste. The user is obligated to take end-of-life devices to a designated collection point for the disposal of electrical and electronic equipment.

CLEANING AND STORAGE

Periodically wipe the case with a damp cloth and mild detergent; do not use abrasives or solvents. Please remove the battery if the meter is stored for a long period of time.

Specifications

Sensor	Professional Fuel Cell technology
HCHO Range	0.00 to 5.00 mg/m ³ (or PPM)
HCHO Resolution	0.01 mg/m ³ (or PPM)
HCHO Basic Accuracy	±5% FS
TVOC Range	0.00 to 9.99 mg/m ³ (or PPM)
TVOC Resolution	0.01 mg/m ³ (or PPM)
TVOC Basic Accuracy	±5% FS
Response Time	≤ 2 seconds
Operating Temperature	0°C to 40°C (32 to 104°F)
Storage Temperature	-10°C to 60°C (14 to 140°F)
Power Supply	Rechargeable Polymer lithium-ion battery (7.4V 1300mAh)
Battery Charge Time	Approx. 3 hours with AC adapter
Battery	7.4V 1300mAh (part # VPC-BATT)
Dimensions	165 x 60 x 25mm (6.5 x 2.4 x 1.0 in.)
Weight	584g (20.6 oz.)

Warranty

Triplett / Jewell Instruments extends the following warranty to the original purchaser of these goods for use. Triplett warrants to the original purchaser for use that the products sold by it will be free from defects in workmanship and material for a period of (1) one year from the date of purchase. This warranty does not apply to any of our products which have been repaired or altered by unauthorized persons in any way or purchased from unauthorized distributors so as, in our sole judgment, to injure their stability or reliability, or which have been subject to misuse, abuse, misapplication, negligence, accident or which have had the serial numbers altered, defaced, or removed. Accessories, including batteries are not covered by this warranty

Copyright © 2021 Triplett