

Digital Power Meter

GPM-8213

USER MANUAL

Test Equipment Depot - 800.517.8431 - 99 Washington Street Melrose, MA 02176

TestEquipmentDepot.com



ISO-9001 CERTIFIED MANUFACTURER

GW INSTEK

This manual contains proprietary information, which is protected by copyright. All rights are reserved. No part of this manual may be photocopied, reproduced or translated to another language without prior written consent of Good Will company.

The information in this manual was correct at the time of printing. However, Good Will continues to improve products and reserves the rights to change specification, equipment, and maintenance procedures at any time without notice.

Table of Contents

SAFETY INSTRUCTIONS	4
GETTING STARTED	9
Characteristics	10
Appearance	13
Set Up	22
BASIC SETTING	25
Setting up measurement range	26
Setting up measurement status	30
Setting up System status	38
MEASUREMENT AND OTHER FUNCTIONS	44
Measurement function	45
Other functions	48
Integration measurement function	50
APPENDIX	57
Specifications	58
Dimensions	62
Declaration of Conformity	63
Power measurement	64
Introduction to IEC-62301	66
EUP Directive Lot6 specifications	67

S SAFETY INSTRUCTIONS

This chapter contains important safety instructions that you must follow during operation and storage. Read the following before any operation to ensure your safety and to keep the instrument in the best possible condition.

Safety Symbols

These safety symbols may appear in this manual or on the instrument.



WARNING

Warning: Identifies conditions or practices that could result in injury or loss of life.



CAUTION

Caution: Identifies conditions or practices that could result in damage to the digital power meter or to other properties.



DANGER High Voltage



Attention Refer to the Manual



Protective Conductor Terminal



Earth (ground) Terminal

Do not dispose electronic equipment as unsorted municipal waste. Please use a separate collection facility or contact the supplier from which this instrument was purchased.

Safety Guidelines

General Guideline • Make sure that the voltage input level does not exceed DC989V/AC700V.



CAUTION

- Make sure the current input level does not exceed 25A.
- Do not place any heavy object on the instrument.
- Avoid severe impact or rough handling that can lead to damaging the instrument.
- Do not discharge static electricity to the instrument.
- Use only mating connectors, not bare wires, for the terminals.
- Do not block or obstruct the cooling fan vent opening.
- Do not perform measurement at the source of a low-voltage installation or at building installations (Note below).
- Do not disassemble the instrument unless you are qualified as service personnel.
- Make sure that the COM terminal to earth is limited to 300Vpk.
- Remove all test leads before disconnecting the mains power cord from the socket.
- If the equipment is used in a manner not specified by the manufacturer, the protection provided by the equipment may be impaired

(Note) EN 61010-1:2010 specifies the measurement categories and their requirements as follows. The GPM-8213 falls under category II 300V.

- Measurement category IV is for measurement performed at the source of low-voltage installation.
- Measurement category III is for measurement performed in the building installation.
- Measurement category II is for measurement performed on the circuits directly connected to the low voltage installation.

Power Supply



WARNING

- AC Input voltage: 100~240 VAC 50/60Hz
- The power supply voltage should not fluctuate more than 10%.
- Connect the protective grounding conductor of the AC power cord to an earth ground, to avoid electrical shock.

Fuse



WARNING

- Fuse type: 2AT 100~240VAC
- Make sure the correct type of fuse is installed before power up.
- To avoid risk of fire, replace the fuse only with the specified type and rating.
- Disconnect the power cord before fuse replacement.
- Make sure the cause of a fuse blowout is fixed before fuse replacement.

Cleaning the Instrument

- Disconnect the power cord before cleaning.
 - Use a soft cloth dampened in a solution of mild detergent and water. Do not spray any liquid.
 - Do not use chemicals containing harsh material such as benzene, toluene, xylene, and acetone.
-

Operation Environment	<ul style="list-style-type: none">• Location: Indoor, no direct sunlight, dust free, almost non-conductive pollution (Note below)• Temperature: 0°C to 50°C• Humidity: < 30°C: < 80%RH(non-condensing); 30°C~40°C:<70%RH(non-condensing); >40°C: <50%RH (non-condensing)• Altitude: <2000m <p>(Note) EN 61010-1:2010 specifies the pollution degrees and their requirements as follows. The GPM-8213 falls under degree 2.</p> <ul style="list-style-type: none">• Pollution refers to “addition of foreign matter, solid, liquid, or gaseous (ionized gases), that may produce a reduction of dielectric strength or surface resistivity”.• Pollution degree 1: No pollution or only dry, non-conductive pollution occurs. The pollution has no influence.• Pollution degree 2: Normally only non-conductive pollution occurs. Occasionally, however, a temporary conductivity caused by condensation must be expected.• Pollution degree 3: Conductive pollution occurs, or dry, non-conductive pollution occurs which becomes conductive due to condensation which is expected. In such conditions, equipment is normally protected against exposure to direct sunlight, precipitation, and full wind pressure, but neither temperature nor humidity is controlled.
Storage environment	<ul style="list-style-type: none">• Location: Indoor• Temperature: -40°C to 70°C• Humidity: <90%RH(non-condensing)
Disposal	<p>Do not dispose this instrument as unsorted municipal waste. Please use a separate collection facility or contact the supplier from which this instrument was purchased. Please make sure discarded electrical waste is properly recycled to reduce environmental impact.</p>

Power cord for the United Kingdom

When using the unit in the United Kingdom, make sure the power cord meets the following safety instructions.

NOTE: This lead/appliance must only be wired by competent persons

 **WARNING: THIS APPLIANCE MUST BE EARTHED**

IMPORTANT: The wires in this lead are coloured in accordance with the following code:

Green/ Yellow:	Earth
Blue:	Neutral
Brown:	Live (Phase)



As the colours of the wires in main leads may not correspond with the coloured marking identified in your plug/appliance, proceed as follows:

The wire which is coloured Green & Yellow must be connected to the Earth terminal marked with either the letter E, the earth symbol  or coloured Green/Green & Yellow.

The wire which is coloured Blue must be connected to the terminal which is marked with the letter N or coloured Blue or Black.

The wire which is coloured Brown must be connected to the terminal marked with the letter L or P or coloured Brown or Red.

If in doubt, consult the instructions provided with the equipment or contact the supplier.

This cable/appliance should be protected by a suitably rated and approved HBC mains fuse: refer to the rating information on the equipment and/or user instructions for details. As a guide, a cable of 0.75mm² should be protected by a 3A or 5A fuse. Larger conductors would normally require 13A types, depending on the connection method used.

Any exposed wiring from a cable, plug or connection that is engaged in a live socket is extremely hazardous. If a cable or plug is deemed hazardous, turn off the mains power and remove the cable, any fuses and fuse assemblies. All hazardous wiring must be immediately destroyed and replaced in accordance to the above standard.

G ETTING STARTED

This chapter describes the GPM-8213 in a nutshell, including accessories, package contents, its main features and front / rear panel introduction.

Characteristics.....	10
Appearance.....	13
Front Panel.....	13
Display Overview.....	17
Rear Panel.....	20
Set Up	22
Tilting the Stand.....	22
Power Up.....	23
Connect the wires to the GPM-8213	24

Characteristics

The GPM-8213 is a high-precision, programmable power meter for using in standby measuring the device with low power such as switching power supplies, transformers, power supplies, adapter and other devices. It equips with a color TFT-LCD screen which is very convenient for reading the measurement results. The GPM-8213 has become a reliable power measurement instruments because of its simple operation, excellent performance and automatic measurement interface.



Operation

- Press the buttons on the front panel to easily turn on the GPM-8213 measurement function. All settings and measurements results are displayed on the TFT-LCD screen panel for easy use of each function.
- Standard display mode: 2 main measurement results and 6 secondary measurement results are displayed in this screen.
- Simple display mode: 4 major measurement results are displayed in this screen.

Performance	<ul style="list-style-type: none">• 6 selectable voltage ranges available from 15V to 300V with 0.1% of reading + 0.1% of range.• 12 selectable current ranges available from 5mA to 20A with 0.1% of reading + 0.1% of range.• It can even measure the voltage of abnormal wave of CF 3. The half-range CF is up to 6.• It can even measure the current of abnormal wave of CF 3. The half-range CF is up to 6.• Test terminals in the front panel.• Total harmonic distortion measurement.
Features	<ul style="list-style-type: none">• Full five-digit measurement.• Voltage measurement range: 15V ~ 600V or automatic switching• Current measurement range: 5mA ~ 20A or automatic switching• Maximum accuracy of 0.1% of reading + 0.1% of range• 2 main measurement readings and 6 minor measurement readings are displayed in the screen of standard display mode.• 4 main measurement readings are displayed in the screen of simple display mode.• Added stand-alone display of total harmonic distortion measurement function (13 steps)• Test bandwidth of voltage and current: DC ~ 6kHz.• Added W-h power time integrator function• Selectable boot settings (Previous / Default)• The command set is conformed to YOKOGAWA WT310E.
Interface	<ul style="list-style-type: none">• Standard interface: USB / RS232 / LAN• Optional interface: GPIB

Application

- It can be applied to production test such as power supplies, transformers, motors, electrical equipment and other equipment with low standby power.
 - It can be applied to power measurement conforms to IEC 62301
 - It can be applied to assess the power consumption of product design.
-

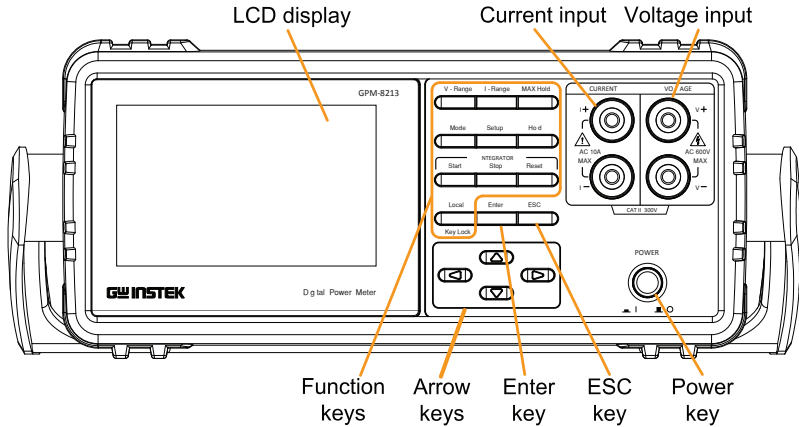

Appearance

Front Panel



Power Switch

POWER

Turns On  or Off  the main power. For the power up sequence, see page 23.

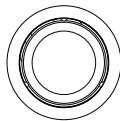

Current, Voltage Terminals

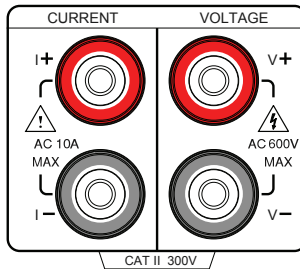

Current input: I+ and I- terminals; Voltage input: V+ and V- terminals.



Note

If the measurement power supply has positive and negative electrode, please connect + to the positive electrode of power supply and - to the negative electrode of power supply.



Warning

The maximum measurable current and voltage are 600 V and 10A for voltage and current terminals of the front panel of the GPM-8213. Do not input exceeded voltage and current, otherwise it will burn the device.

Function keys

V - Range

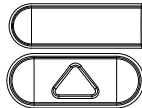

V-Range key, up/down arrow keys and Enter key can be used together to select a voltage range or auto range measurement mode. See page 26.

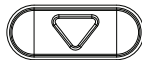

Enter



I - Range

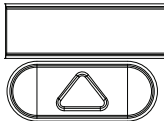

I-Range key, up/down arrow keys and Enter key can be used together to select a current range or auto range measurement mode. See page 26.

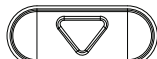

Enter



MAX Hold Press this button to display the maximum measurement reading. See page 48.



Mode Press this key to select measure mode (DC/AC/AC+DC). See page 48.



Setup Press this key to enter the measurement settings menu. See page 30.



Hold Press this key to switch window and stop refreshing. See page 49.

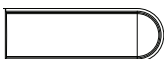

Enter

Use the left and right arrow keys to select Integrator mode, and press Enter button to enter the time integrator function. See page 50.

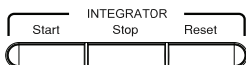

Local Press this key to toggle to key lock. In Remote control mode, press this button to switch to local mode. See page 49.



Key Lock

Confirm button

Enter This button is used to enter the menu, confirm the settings and switch between the standard display mode and simple display mode (no function table and display icon). See page 49.



Cancel (Exit)
button



Press this button to cancel the current setting. The cursor returns to the default position or return to the previous menu according to the situation. See page 49.

Arrow Keys

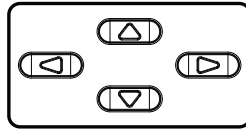

This for arrow keys are used to edit the parameters, browse the menu system and select the parameter range.

Display Overview

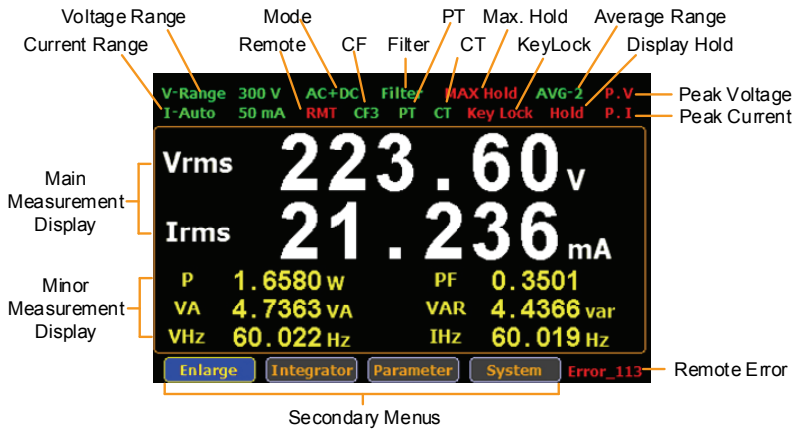

Item	Status icon	Description
Voltage Range	V_Range 300V	Voltage measurement range. Example here range is 300V. V_Auto means that Auto Range is turned on.
Current Range	I_Auto 50mA	Current measurement range. Example here range is 50mA. I_Auto means that Auto Range is turned on.
Mode	AC+DC	Measurement mode (AC, DC, AC+DC)
Remote	RMT	Remote control mode (on/off)
Crest Factor	CF3	Crest Factor (3/6)
Filter	Filter	Voltage and current filters (on/off)
PT Ratio State	PT	External voltage magnification (on/off)

CT Ratio State	CT	External current magnification (on/off)
Maximum Hold	Max. Hold	Retain and display the maximum measurement reading.
Keyboard Lock	KeyLock	Lock Key button
Average	Avg-1	Average number of sampling (1/2/4/8/16/32/64)
Display Hold	Hold	Retain and display the current measurement reading.
Peak Voltage	P.V	The voltage exceeds the measurement range
Peak Current	P.I	The current exceeds the measurement range
Remote Error	Err-XXX	An error occurs in remote command
Standard Display Mode	Display the measurement result of 2 major and 6 minor measurement parameters	
Simple Display Mode	Display the measurement result of 4 major measurement parameters	
Secondary menus	Display secondary function menu	
	• Enlarge	This function key is used to switch display of measurement result from 2 major plus 6 minor to 4 major ones.
	• Integrator	This function key is used to set up integrator measurement parameters and execute integrator measurement function.
	• Parameter	This function key is used set up measurement parameters.

- System This function key is used to enter the system setting and system configuration screens.

Rear Panel

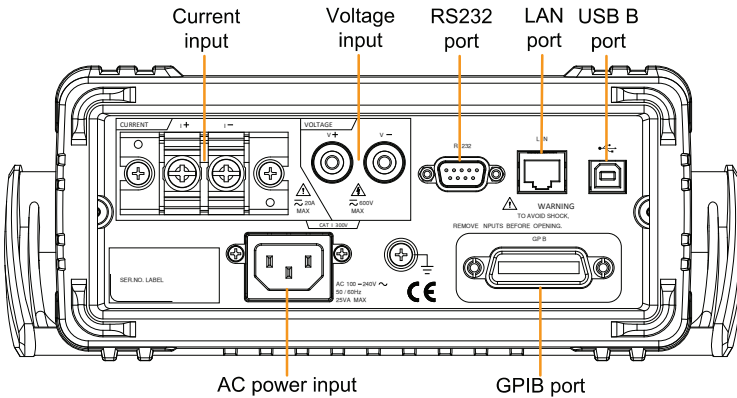

Power Cord Socket

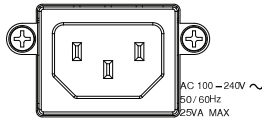

Accepts the power cord.
AC 100~240V ±10%,
50/60Hz

RS232

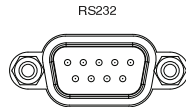

RS232 port. This port is used for remote control.

USB Device Port

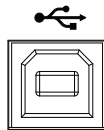

Type B USB port. This port is used for remote control.

LAN Port

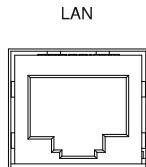

LAN Port.

Rear
Voltage/Current
input terminal

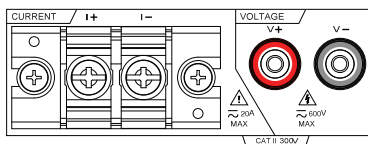

Rear
Voltage/Current
input terminals is
used to connect
the main
measurement
signals.



Warning

- Do not use damaged device. Before using the equipment, check its housing first to sure there is no any cracks. Do not operate this device in an environment containing explosive gases, steam or dust.
- The maximum measurable current and voltage are 600 V and 20A for voltage and current terminals of the rear panel of the GPM-8213. Do not input exceeded voltage and current, otherwise it will burn the device.
- Always use the supplied cable for connection.
- Before connecting the device, observe all the safety symbols marked on the device.
- Turn off the power to the device and the application system before connecting I/O terminals.
- Do not install replacement parts on the device or perform any unauthorized modifications.
- Do not use this device if the removable cover is removed or loosened.
- Do not connect any cables and terminals before performing self-test.
- Use only the power adapter supplied by the manufacturer to avoid accidental injury.
- Do not use this device for life support systems or any other equipment that has safety requirements.

Set Up

Tilting the Stand

From the base of the handle, gently pull the handle out sideways and then rotate it to one of the following positions.

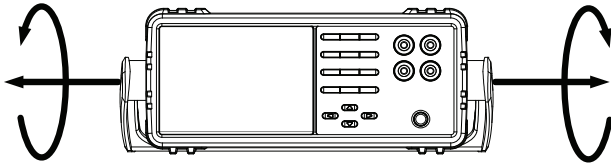

Horizontal position

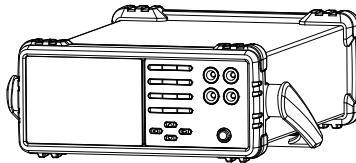

Tilt stand position

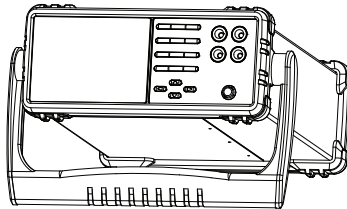

Carry position

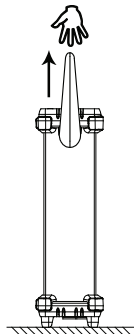

Power Up

Steps

1. Ensure the AC voltage is 100~ 240V.
2. Connect the power cord to the AC voltage input.

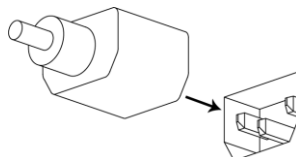

Note

Make sure the ground connector on the power cord is connected to a safety ground. This will influence the measurement accuracy.

3. Push to turn on the main power switch on the front panel.



4. The display turns on and shows the last function that was used before the power was reset.

Connect the wires to the GPM-8213

Background Two separate wires is used to connect the GPM-8213, so voltage and current measurement are isolated and don't interfere with each other.

Connection diagram

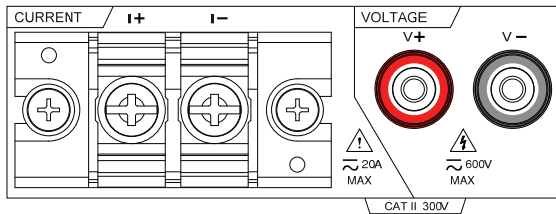
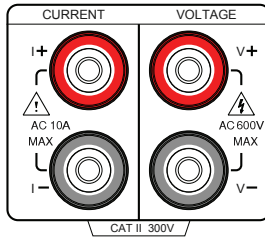

Note

The terminals on the front and rear panels can't be used as input terminal at the same time.

Description

- V + The positive voltage input (+)
- V - The negative voltage input (-)

- I + The positive current input (+), 10A for input on the front panel, 20A for input on the rear panel.
- I - The negative current input (-), 10A for input on the front panel, 20A for input on the rear panel.

- GND Provide reference grounding.

BASIC SETTING

Setting up measurement range	26
Auto Range	28
Setting up measurement status	30
Setting up synchronization source	30
Setting up filter	31
Setting up crest factor	32
Setting up auto-zero function	33
Setting up average value	34
Setting up method of calculating harmonics	35
Setting up the PT ratio status	36
Setting up the CT ratio status	37
Setting up System status	38
System configuration setting screen	38
Setting up power on status	38
Setting up brightness	39
Setting up key sound	40
Setting up interface	41
Configure RS232 Interface	43

Setting up measurement range

To get the accurate measurement results, you should set an appropriate measurement range before you perform measurement task.

Set voltage range 1. Press **V-Range** button.

V - Range



2. Use up and down arrow keys to select the desired range.

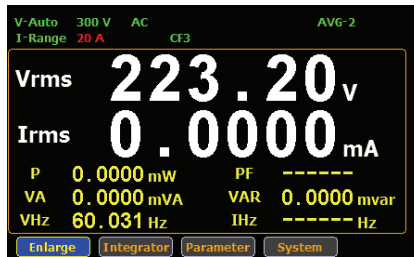

3. Press **Enter** button to confirm your selection.

Enter



Available range Crest Factor AUTO, 15V, 30V, 60V, 150V, 300V, 600V is 3:

Crest Factor AUTO, 7.5V, 15V, 30V, 75V, 150V, 300V is 6:

Set current range 1. Press **I-Range** button.

I - Range



- Use up and down arrow keys to select the desired range.

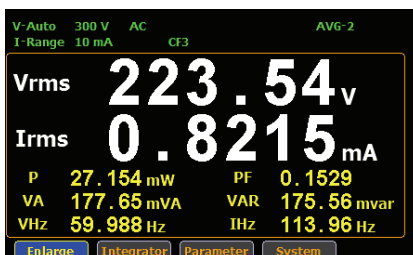
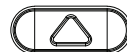

- Press **Enter** button to confirm your selection.

Enter



Available range	Crest Factor is 3:	AUTO, 5mA, 10mA, 20mA, 50mA, 100mA, 200mA, 0.5A, 1A, 2A, 5A, 10A, 20A
	Crest Factor is 6:	AUTO, 2.5mA, 5mA, 10mA, 25mA, 50mA, 100mA, 250mA, 0.5A, 1A, 2.5A, 5A, 10A

 Note

When the measurement range is set manually, if the range status icon lights in green means that the measured value meets the setting range. On the contrary, If the range status icon lights in red means that the measured value doesn't meet the best setting range. In this case. It is better to switch to other range to get more accurate measurement results.

 Note

The P.I status icon lights in red when the current measurement circuit detects that the measured value exceeds setting range by 3 folds (CF is set to 3) or 6 folds (CF is set to 6).



Note

The P.V status icon lights in red when the voltage measurement circuit detects that the measured value exceeds setting range by 3 folds (CF is set to 3) or 6 folds (CF is set to 6).

Auto Range

The range is automatically switched according to the voltage and current of input signal.

Range is shift up

The range is shifted up when either of the following conditions is met.

- Vrms or Irms exceeds the current setting range by 110%.
 - The Vpk or Ipk value of the input signal exceeds the current setting range by 330% at CF 3.
 - The Vpk or Ipk value of the input signal exceeds the current setting range by 660% at CF 6.
-

Range is shift down

The range is shifted down when all of the following conditions are met.

- Vrms or Irms is equal to or less than the 60% of previous range.
- The Vpk or Ipk value of the input signal is less than the next setting range by 300% at CF 3.
- The Vpk or Ipk value of the input signal is less than the next setting range by 600% at CF 6.

Example

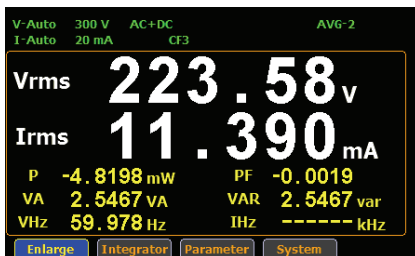



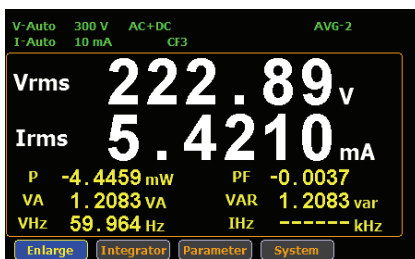



Irms exceeds the current setting range by 110%, so range is shifted to 20mA



Irms is less than or equal to 60% of the previous setting range, so range is shifted down to 10mA.

Setting up measurement status

Setting up synchronization source

- | | | |
|-------|--|---|
| Steps | 1. Press Setup button. | Setup
 |
| | 2. Press Enter button. | Enter
 |
| | 3. Press down arrow key. |  |
| | 4. Press Enter button to enter Sync Source item. Use up and down arrow keys to select the desired option and then press Enter button again to confirm your selection. | Enter

 
Enter
 |









- | | |
|--------|--|
| Option | V: Select the voltage of signals as synchronization source.

I: Select the current of signals as synchronization source.

OFF: Select the entire interval of data updating period as synchronization source. |
|--------|--|

Default value V







Setting up filter

- | | | |
|-------|---|---|
| Steps | 1. Press Setup button. | Setup
 |
| | 2. Press Enter button. | Enter
 |
| | 3. Press down arrow key twice. |  x2 |
| | 4. Press Enter button to enter Filter item. Use up and down arrow keys to select the desired option and then press Enter button again to confirm your selection. | Enter

 
Enter
 |



- | | |
|---------------|---|
| Option | On: Turn on the line filter function and Filter status icon on the display lights up in green. |
| | Off: Turn off the line filter function. Line filter cutoff frequency is 500Hz |
| Default value | Off |

Setting up crest factor







- | | | |
|-------|---|---|
| Steps | 1. Press Setup button. | Setup
 |
| | 2. Press Enter button. | Enter
 |
| | 3. Press down arrow key three times. |  x3 |
| | 4. Press Enter button to enter Crest Factor item. Use up and down arrow keys to select the desired option and then press Enter button again to confirm your selection. | Enter

 
Enter
 |



- | | |
|--------|---------------------------|
| Option | 3: Crest Factor is three. |
| | 6: Crest Factor is six. |

Default value 3



Setting up auto-zero function

- | | | |
|-------|--|---|
| Steps | 1. Press Setup button. | Setup
 |
| | 2. Press Enter button. | Enter
 |
| | 3. Press down arrow key four times. |  x4 |
| | 4. Press Enter button to enter Auto Zero item. Use up and down arrow keys to select the desired option and then press Enter button again to confirm your selection. | Enter

 
Enter
 |



- | | |
|---------------|--|
| Option | <p>On: Auto-zero function is activated once per hour or when range is switched</p> <p>Off: Auto-zero function is only activated once when the range is switched. The auto-zero function is turned off when the integrator function is executed</p> |
| Default value | Off |

Setting up average value

- | | | |
|-------|--|---|
| Steps | 1. Press Setup button. | <div style="text-align: right; margin-bottom: 5px;">Setup</div> <div style="border: 1px solid black; width: 100px; height: 20px; margin: 0 auto;"></div> |
| | 2. Press Enter button. | <div style="text-align: right; margin-bottom: 5px;">Enter</div> <div style="border: 1px solid black; width: 100px; height: 20px; margin: 0 auto;"></div> |
| | 3. Press down arrow key five times. | <div style="text-align: right; margin-bottom: 5px;"> x5</div> |
| | 4. Press Enter button to enter Average item. Use up and down arrow keys to select the desired option and then press Enter button again to confirm your selection. | <div style="text-align: right; margin-bottom: 5px;">Enter</div> <div style="border: 1px solid black; width: 100px; height: 20px; margin: 0 auto; margin-bottom: 5px;"></div> <div style="text-align: right; margin-bottom: 5px;"> </div> <div style="text-align: right; margin-bottom: 5px;">Enter</div> <div style="border: 1px solid black; width: 100px; height: 20px; margin: 0 auto;"></div> |









Option 1, 2, 4, 6, 8, 16, 32 and 64:

The measurement time is synchronized with the average value that you set. The larger the average value is, the longer the measurement time is. When the average value is set to 1, the measurement time is about 0.1 seconds. The larger the number is, the longer the measurement time is, and so forth.

Default value 2

Setting up method of calculating harmonics



- | | | |
|-------|--|---|
| Steps | 1. Press Setup button. | Setup
 |
| | 2. Press Enter button. | Enter
 |
| | 3. Press down arrow key six times. |  x6 |
| | 4. Press Enter button to enter Harmonics item. Use up and down arrow keys to select the desired option and then press Enter button again to confirm your selection. | Enter

 
Enter
 |



- | | |
|--------|--|
| Option | IEC: Calculate the ratio of harmonic quantity of the 2nd through the 13th harmonic to the 1st harmonic. |
| | CSA: Calculate the ratio of harmonic quantity of the 2nd through the 13th harmonic to the 1st through the 13th harmonic. |
| | Off: Turn off the harmonic calculation function. |

Default value Off









Setting up the PT ratio status

- | | | |
|-------|--|---|
| Steps | 1. Press Setup button. | Setup
<input style="width: 100px; height: 20px; border: 1px solid black;" type="text"/> |
| | 2. Press Enter button. | Enter
<input style="width: 100px; height: 20px; border: 1px solid black;" type="text"/> |
| | 3. Press down arrow key seven times. |  x7 |
| | 4. Press Enter button to enter PT Ratio Status item. Use up and down arrow keys to select the desired option and then press Enter button again to confirm your selection. | Enter
<input style="width: 100px; height: 20px; border: 1px solid black;" type="text"/>
 
Enter
<input style="width: 100px; height: 20px; border: 1px solid black;" type="text"/> |



- | | | |
|----------------|------|--|
| Option | On: | Turn on the PT ratio calculation function and PT status icon on the display lights up in green. The setting range is from "1" to "9999.999". |
| | Off: | Turn off the PT ratio calculation function. |
| Default option | Off | |

Setting up the CT ratio status



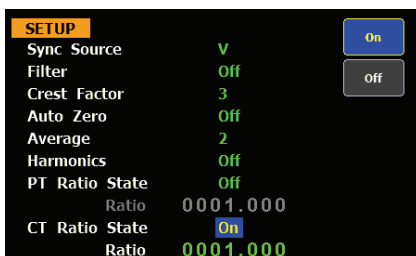



- | | | |
|-------|--|---|
| Steps | 1. Press Setup button. |  |
| | |  |
| | 2. Press Enter button. | Enter
 |
| | 3. Press down arrow key eight times. |  x8 |
| | 4. Press Enter button to enter CT Ratio Status item. Use up and down arrow keys to select the desired option and then press Enter button again to confirm your selection. | Enter

 
Enter
 |



- | | |
|----------------|--|
| Option | On: Turn on the CT ratio calculation function and CT status icon on the display lights up in green. The setting range is from "1" to "9999.999". |
| | Off: Turn off the CT ratio calculation function. |
| Default option | Off |

Setting up System status

System configuration setting screen

- | | | |
|-------|---|--|
| Steps | <ol style="list-style-type: none"> 1. Use left and right arrow keys on the front panel to select System function key. | 
 |
| | <ol style="list-style-type: none"> 2. Press Enter button to Enter SYSTEM INFORMATION setting screen. | Enter
 |
| | <ol style="list-style-type: none"> 3. Press right arrow key to select Config key. |  |
| |  | |
| | <ol style="list-style-type: none"> 4. Press Enter button to enter SYSTEM CONFIG setting screen. | Enter
 |

Setting up power on status

Background Continue the following setting from **SYSTEM CONFIG** setting screen

- | | | |
|-------|--|---|
| Steps | <ol style="list-style-type: none"> 1. Press down arrow key. |  |
|-------|--|---|

2. Press **Enter** button to enter **Power On Status Setup** item. Use up and down keys to select the desired option and then press **Enter** button again to confirm your selection.

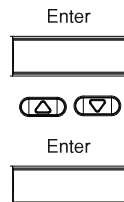

Option	<p>Previous: The status of device on powering on is set to the status before the last shutdown.</p> <p>Default: The status of device on powering on is set to the factory default status.</p>
Default value	Default

Setting up brightness

Background Continue the following setting from **SYSTEM CONFIG** setting screen

- | | | |
|-------|--------------------------------|--|
| Steps | 1. Press down arrow key twice. |  x2 |
|-------|--------------------------------|--|

- Press **Enter** button to enter **Brightness** item. Use up and down keys to select a number and then press **Enter** button again to confirm your selection.

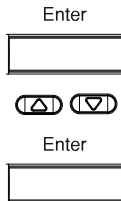

Option	1 to 9	The display is the darkest when set to 1. On the contrary, the brightest when set to 9.
--------	--------	---

Default option	7
----------------	---

Setting up key sound

Background	Continue the following setting from SYSTEM CONFIG setting screen
------------	---

- | | |
|-------|--|
| Steps | 1. Press down arrow key three times. _{x3} |
|-------|--|

2. Press **Enter** button to enter **Key Sound** item. Use up and down arrow keys to select the desired option and then press **Enter** button again to confirm your selection.

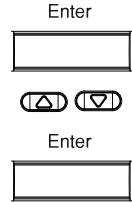

Option	On:	A short sound is heard from the speaker of device when pressing the keys on the front panel.
	Off:	No sound from the speaker of device when pressing the keys on the front panel.

Default option Off

Setting up interface

Background Continue the following setting from **SYSTEM CONFIG** setting screen

Steps 1. Press down arrow key four times.  x4

2. Press **Enter** button to enter **I/O Model** item. Use up and down arrow keys to select the desired option and then press **Enter** button again to confirm your selection.

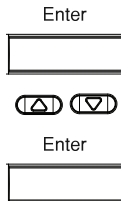

Option	<p>RS232: If interface is set to RS232, the Baud Rate can be selected from the following options.</p> <p style="padding-left: 40px;">1200, 2400, 4800, 9600, 19200, 38400, 57600 or 115200</p> <p>USB:</p> <p>GPIB: If interface is set to GPIB, the GPIB address can be selected from “1” to “30”</p> <p>LAN: If interface is set to LAN, the IP model is can be selected from “Manual” and “DHCP”</p>
Default value	RS232, 9600

Configure RS232 Interface

RS232 Configuration	Selectable Baud rate	1200, 2400, 4800, 9600, 19200, 38400, 57600, 115200
	Parity	None
	Hardware flow control	Off
	Data Bits	8
	Stop bit	1

RS232 Pin Assignments	Pin 2: RxD
	Pin 3: TxD
	Pin 5: GND
	Pin 1, 4, 6 ~ 9: No Connection

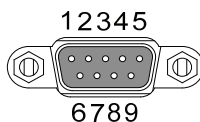

PC Connection Use a Null Modem connection as shown in the diagram below.

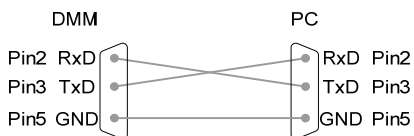

M EASUREMENT AND **OTHER FUNCTIONS**

Measurement function.....	45
Introduction to measurement parameters	45
Setting measurement parameters.....	46
Other functions	48
Introduction to other functions.....	48
Integration measurement function	50
Setting up Integrator measurement.....	50
Introduction to integrator parameters	53
Using the integrator function	55

Measurement function

The GPM-8213 provides a wide range of basic electricity and power measurement functions. It equips with different accurate measurement parameters for accurately measuring the voltage, current, power, DC/AC/AC + DC, power factor, harmonics, frequency, etc. The input impedance of the device is 2.4MΩ, the maximum input voltage is 600Vrms. There are 2 sets of internal resistance (Shunt), 500mΩ and 5mΩ respectively. The maximum input current is 20Arms. The device will issue a warning sound when the input voltage and current exceed 700 Vrms or 25Arms.

Introduction to measurement parameters

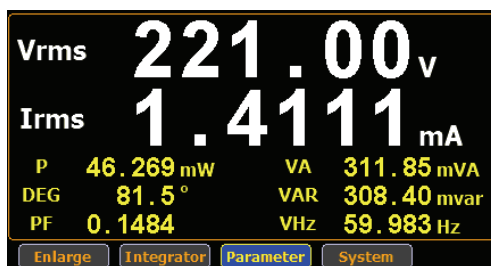

Parameter name	Display icon
Voltage	Vdc (DC voltage), Vrms (AC voltage)
Current	Idc (DC current), Irms (AC current)
Active Power	P
Apparent Power	VA
Reactive power	VAR
Power Factor	PF
Phase Angle	DEG
Frequency	IHz and VHz
Voltage Peak	V+pk and V-pk
Current Peak	I+pk and I-pk

Active Power Peak P+pk and P-pk

Total Harmonic Distortion THDI and THDV

Crest factor CFV, CFI

Setting measurement parameters

Please follow the steps blow to set the measurement parameters

Steps

1. Use left and right arrow keys on the front panel to select **Parameter** function key.

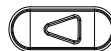

2. Press **Enter** button. A measurement parameter will be highlighted in green.

Enter



3. Press **Enter** button to confirm setting or use up and down arrow keys to select other desired measurement parameter.

Enter



Enter

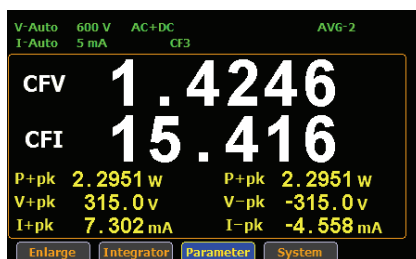

4. You can use same way as show in last step to set other measurement parameters in this screen.

- Switching display mode 5. In standard display mode, you simply press the **Enter** button to switch display mode to simple one.

Enter

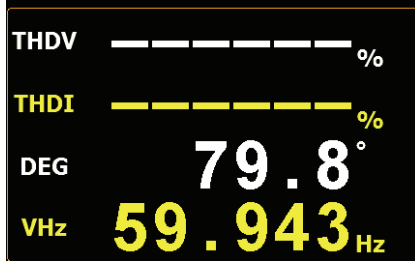



6. Press **ESC** button to return back to original display mode.

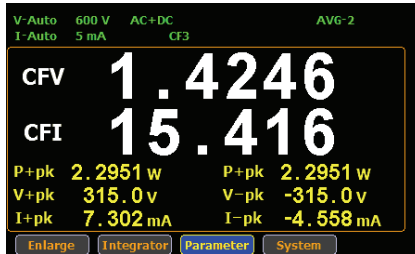



ESC



Other functions

Introduction to other functions

Function name	Button	Description
MAX Hold	MAX Hold 	<p>When the MAX Hold button is pressed, the MAX Hold status icon will light in red in the LCD display to indicate that this function is activated. To deactivate this function, press this button again.</p> <p>If the MAX Hold function is activated, the display value on the display is updated only when the current measured value is greater than the previous measured value. The maximum display value is retained on the display.</p>
Mode	Mode 	<p>Press this button to select measurement mode. There are 3 measurement modes.</p> <ul style="list-style-type: none"> • AC+DC: Displays all the components of the measurement signal • DC: Displays the DC part of the measurement signal. • AC: Displays the AC part of the measurement signal.

Hold	<p>Hold</p> 	<p>When the Hold button is pressed, the Hold status icon will light in red in the LCD display to indicate that this function is activated. To deactivate this function, press this button again.</p> <p>When the Hold function is activated, the displayed value on the LCD display is not updated and the range is locked. Measurement is performed in the background.</p>
Local/ KeyLock	<p>Local</p>  <p>Key Lock</p>	<p>Dual function key. When Remote mode is activated, press this button to deactivate Remote mode and switch to Local mode. When Remote mode is not activated, this button is used as lock key of keypad.</p>
Enter	<p>Enter</p> 	<p>This button is used to select function or confirm selection.</p>
ESC	<p>ESC</p> 	<p>This button is used to exit current screen or return to main measurement screen.</p>

Integration measurement function

Setting up Integrator measurement

steps

1. Use left and right arrow keys on the front panel to select **Integrator** function key.

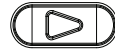
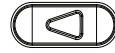

2. Press **Enter** button to enter the integrator measurement screen.

Enter

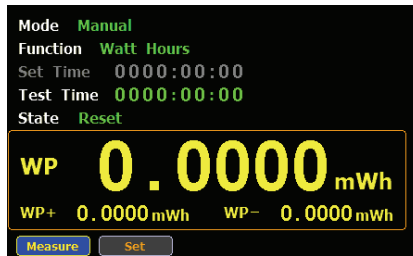

3. Press right arrow key to select **Set** key.



Select integrator measurement mode

4. Press **Enter** button to enter integrator measurement setting screen.

Enter

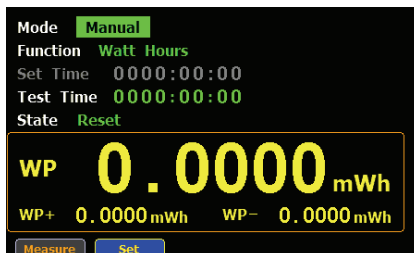

5. Press **Enter** button to enter **Mode** item. Use up and down arrow keys to toggle between Manual and Standard mode. Press Enter button again to confirm your selection.

Enter



Enter

If you select Manual mode, the Set time become disable and displayed in gray.

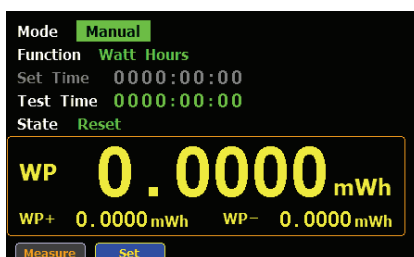

If you select standard mode, you need to set integrator measurement time before using integrator function. It can be set from 1 second to 9999 hours, 59 minutes and 59 seconds.



6. Press down arrow key to select **Function** item in the integrator measurement setting screen.



Select integrator measurement function

7. Press **Enter** button to enter **Function** item. Use up and down arrow keys to toggle between Ampere Hours and Watt Hours. Press Enter button again to confirm your selection.

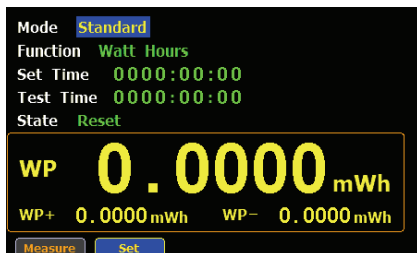
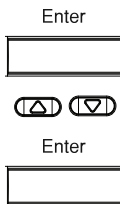

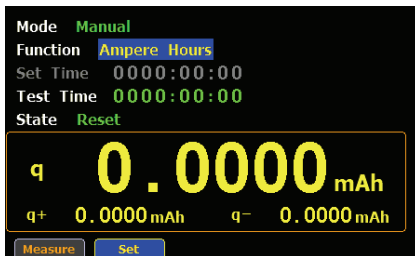

Introduction to integrator parameters

Parameter name	Description
----------------	-------------

Mode	<ul style="list-style-type: none"> • Manual • Standard
------	--

Function	<ul style="list-style-type: none"> • Watt Hours WP: Total power WP+: Positive total power WP-: Negative total power • Ampere Hours q: Total mAh q+: Positive total mAh q-: Negative total mAh
----------	---

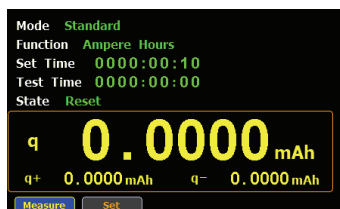

Set time	It indicates the time of integrator measurement to be set. It can be set from 1 second to 9999 hours, 59 minutes and 59 seconds.
----------	--

Test time	It indicates that elapsed time of integrator measurement.
-----------	---

State

- **Running**
Integrator measurement is in progress.
- **Stop**
Integrator measurement has been stopped manually.
- **Timeout**
The time for running integrator measurement is up.
- **Reset**
The integrator measurement status is cleared.

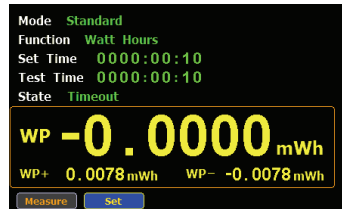

Using the integrator function

Manual mode

1. In manual mode, you can directly press the **Start** button in the front panel to start integrator function.

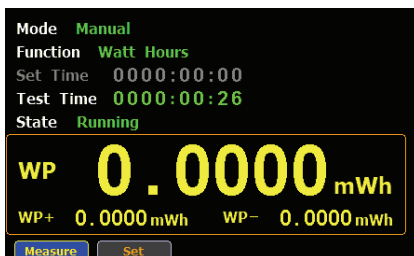
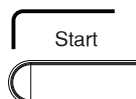

2. To stop integration function, press the **Stop** button in the front panel.



3. Press the **Reset** button in the front panel to clear integrator.

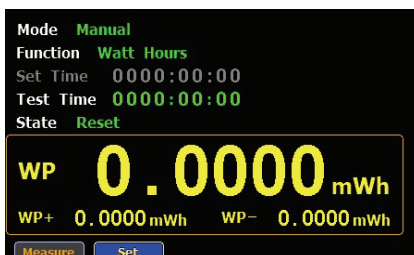
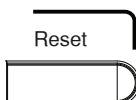

- Standard mode
1. Set integrator measurement time before using integrator function.
 2. Other steps are same as running in manual mode.

When integrator performing, the test time will increase until the setting integrator measurement time.



Note

- In the integration process, select the **Measure** key and press **Enter** button to return main measurement screen. Select **Integrator** key and press **Enter** button to switch back to integration measurement screen.
- In the integration process, you can't change measurement range and enter system to set measurement parameters.
- In the integration process, if the voltage or current measurement value exceeds, the measured value will display in red.

APPENDIX

Specifications.....	58
Input.....	58
Display.....	59
Voltage Measurement.....	59
Current Measurement.....	60
Power Measurement.....	60
Frequency Measurement.....	61
Integrator Measurement.....	61
Dimensions.....	62
Declaration of Conformity.....	63
Power measurement.....	64
Introduction to IEC-62301.....	66
EUP Directive Lot6 specifications.....	67

Specifications

Below are the basic conditions required to operate the GPM-8213 within specifications:

- Calibration: Yearly
- Operating Environment: 18~28 °C (64.4~82.4°F)
- Humidity: <80%RH,
- Accuracy: \pm (% of reading + % of range)
- The specifications apply when it warmed up for at least 30 minutes and operates in the slow rate.
- The power supply cable must be grounded to ensure accuracy.
- Input voltage and current must be standard sine wave.
- The power factor must be 1.
- The crest factor must be 3.
- The common-mode voltage must be zero.

Input

Item	Spec.		
Input voltage	600 Vrms		
Input current	20 Arms		
Input impedance(50/60 Hz)	Voltage	2.4M Ω	
	Current	5mA - 200mA	500m Ω
		0.5A - 20A	5m Ω
Maximum allowable input voltage	700 Vrms		
Maximum allowable input current	25 Arms		
Maximum allowable isolation voltage	300 V		
Low frequency filter	Cut-off frequency	500 Hz	

Display

Synchronization frequency	45Hz~ 6kHz
Average	1, 2, 4, 8, 16, 32, 64
Displayed items(Standard mode)	8 items simultaneously.
Displayed items(Simple mode)	4 items simultaneously.
Displayed digits	5
Voltage converter	1 to 9999.999
Current converter	1 to 9999.999
Measurement items	Voltage, current, active power, apparent power, reactive power, power factor, phase angle, frequency, integrated current, integrated power, positive integrated power, negative integrated power, integration time, voltage crest factor, current crest factor, voltage peak, current peak, Thd
Displayed measurement parameters	Vdc, Vrms, V+pk, V-pk, Idc, Irms, I+pk, I-pk, P, P+pk, P-pk, VA, VAR, PF, CFV, CFI, DEG, VHz, IHz, THDV, THDI

Voltage Measurement

Measurement range	CF=3 : 15V, 30V, 60V, 150V, 300V, 600V CF=6 : 7.5V, 15V, 30V, 75V, 150V, 300V
Crest factor	3, 6
Effective range	1 % to 105 % of range
DC	$\pm(0.2 \% \text{ reading} + 0.2 \% \text{ range})$
45 Hz \leq f \leq 66 Hz	$\pm(0.1 \% \text{ reading} + 0.1 \% \text{ range})$
66 Hz < f \leq 1kHz	$\pm(0.1 \% \text{ reading} + 0.2 \% \text{ range})$
1 kHz < f \leq 6kHz	$\pm 3 \% \text{ of range}$
The filter is turned on	Increase 0.3 % reading@ 45Hz to 66Hz

Temperature effect	5-18 °C / 28-40 °C	Increase $\pm 0.03\%$ reading / °C
Residual noise		0.5 % of range

Current Measurement

Measurement range		5mA, 10mA, 20mA, 50mA, CF=3 : 100mA, 200mA, 500mA, 1A, 2A, 5A, 10A, 20A
		2.5mA, 5mA, 10mA, 25mA, CF=6 : 50mA, 100mA, 250mA, 0.5A, 1A, 2.5A, 5A, 10A
Crest factor		3, 6
Accuracy	Effective range	1 % to 105 % of range
	DC	$\pm(0.2\% \text{ reading} + 0.2\% \text{ range})$
	45 Hz $\leq f \leq$ 66 Hz	$\pm(0.1\% \text{ reading} + 0.1\% \text{ range})$
	66 Hz $< f \leq$ 1kHz	$\pm(0.1\% \text{ reading} + 0.2\% \text{ range})$
	1 kHz $< f \leq$ 6kHz	$\pm 3\%$ of range
	The filter is turned on	Increase 0.3 % reading@ 45Hz to 66Hz
Temperature effect	5-18 °C / 28-40 °C	Increase $\pm 0.03\%$ reading / °C
Residual noise		0.5 % of range

Power Measurement

Accuracy	Effective range	1 % to 110 % of range
	DC	$\pm(0.2\% \text{ reading} + 0.2\% \text{ range})$
	45 Hz $\leq f \leq$ 66 Hz	$\pm(0.1\% \text{ reading} + 0.1\% \text{ range})$
	66 Hz $< f \leq$ 1kHz	$\pm(0.1\% \text{ reading} + 0.3\% \text{ range})$
	1 kHz $< f \leq$ 6kHz	$\pm 3\%$ of range
	The filter is turned on	Increase 0.3 % reading@ 45Hz to 66Hz
Temperature effect	5-18 °C / 28-40 °C	Increase $\pm 0.03\%$ reading / °C

Frequency Measurement

Measurement range	The filter is turned on	30.000Hz to 499.99Hz
	The filter is turned off	30.000Hz to 9.9999kHz
Measurement items	Voltage, Current	
Effective input range	10% to 105% of voltage input range	
Accuracy	$\pm(0.06\% \text{ reading})$	

Integrator Measurement

Integrator	Accuracy	$\pm(\text{Accuracy of voltage or current} + 0.1\% \text{ reading})$
Time	Range	0 hour 0 minute to 9999 hours 59 minutes
	Accuracy	$\pm 0.01\% \pm 1 \text{ second}$

Dimensions

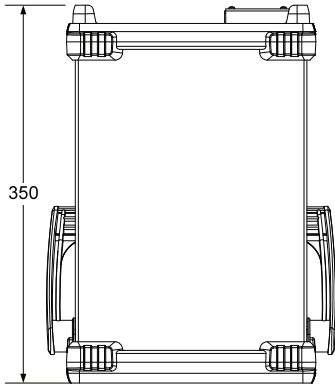

Units = mm

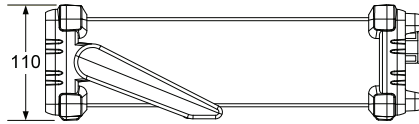
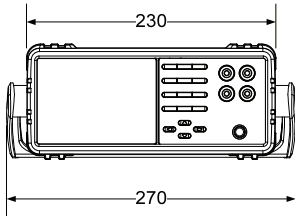

Declaration of Conformity

We

GOOD WILL INSTRUMENT CO., LTD.

declare that the below mentioned product

Type of Product: Digital Power Meter

Model Number: GPM-8213

are herewith confirmed to comply with the requirements set out in the Council Directive on the Approximation of the Law of Member States relating to EMC (2014/30/EU), LVD (2014/35/EU), WEEE (2012/19/EU) and RoHS (2011/65/EU).

For the evaluation regarding the Electromagnetic Compatibility and Low Voltage Directive, the following standards were applied:

© EMC	
EN 61326-1 : EN 61326-2-1:	Electrical equipment for measurement, control and laboratory use — EMC requirements (2013)
Conducted and Radiated Emissions EN 55011:2016	Electrical Fast Transients EN 61000-4-4: 2012
Current Harmonic EN 61000-3-2:2014	Surge Immunity EN 61000-4-5: 2014
Voltage Fluctuation EN 61000-3-3:2013	Conducted Susceptibility EN 61000-4-6: 2014
Electrostatic Discharge EN 61000-4-2: 2009	Power Frequency Magnetic Field EN 61000-4-8:2010
Radiated Immunity EN 61000-4-3:2006+A1:2008+A2:2010	Voltage Dips/ Interrupts EN 61000-4-11: 2004
Low Voltage Equipment Directive 2014/35/EU	
Safety Requirements	EN 61010-1:2010 (Third Edition) EN 61010-2-030:2010 (First Edition)

Power measurement

- Method
- Direct read method: Directly read the measurement value measured from power measuring instrument.
 - The average power method: Record the actual power value within a settable time and then take the average. Settable time isn't less than 10min. The maximum measurement interval is one second.
 - Energy accumulation method: Measure the energy within a settable time and then divide it by the time to get the power. Settable time isn't less than 10min. The cumulative energy must be greater than the resolution by 200 times.
-

- Connection
- Small current: Voltage measurement mode measured from power supply side (Connect to ammeter internally). The current measurement is accurate. The voltage measurement on load could be larger than the actual one due to partial pressure of multi-measurement ammeter.

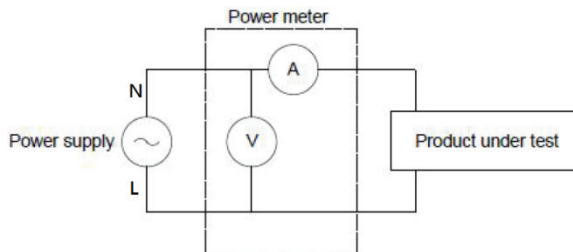

- Large current: Voltage measurement mode measured from load side (Connect to ammeter externally).

The voltage measurement is accurate. The current measurement on load could be larger than the actual one due to leakage current of multi-measurement voltage.

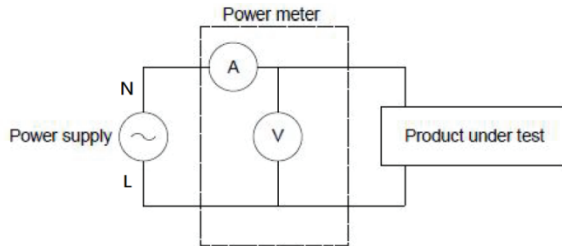

Introduction to IEC-62301

IEC 62301-2011 standard is an international basic standard for measuring standby power consumption of household appliances which is issued by IEEC. It is a standby power consumption measurement method for the various household appliances, power supply, audio and video appliances to comply with. The latest version for this standard is second edition of German standard IEC62301: 2011 (British regulations EN50564: 2011) which is issued on January, 2011. Only the products comply to the standard can have CE marking affixed on it.

Recommended parameters for power measurement instruments.

- Power resolution is less than or equal to 1mW.
- Time integrator function is available.
- Electric energy resolution is less than or equal to 1mWh and cumulative time resolution is less than or equal to 1 second.
- The crest factor is greater than or equal to 3.
- The minimum current range is less than or equal to 10mA.
- The active power includes AC and DC components.
- Over-range automatic alarm function is available.
- Turning off the auto range function is available.
- Harmonic bandwidth is greater than or equal to 2.5kHz.

The GPM-8213 meets all of the features listed above.

EUP Directive Lot6 specifications

Ecodesign directive for energy-using products:

The power loss requirement for the products with external power supply such as information devices, consumer electronics product, household appliances, toys, entertainment and sports products and so on in standby and off mode is as below.

Mode/Limit		2010.01	2013.01
Standby mode	Products with time display function.	$\leq 2W$	$\leq 1W$
	Products without time display function.	$\leq 1W$	$\leq 0.5W$
Shutdown mode		$\leq 1W$	$\leq 0.5W$