

# TAKE WEIGHING **PRECISION** AND **PROTECTION** TO NEW HEIGHTS

## Advanced Sensor Technology

**Smart-SHS** the latest advancement in our super hybrid design, construction & algorithms

- Increased productivity via faster stabilization times (1 second in fast mode)
- Lower cost of ownership due to reduce number of parts and maintenance accessibility

## Innovative Solutions

**Electronically Controlled Load (ECL)** Initially does a self-diagnostic before performing an internal repeatability test without an external weight in < 1.5 minutes.

- *Dia-Check* is the diagnostic result that validates if the balance critically passes or fails.
- *SD* is standard deviation that allows for daily precision check ideal for S.O.P's
- *QuickMin-S* determines minimum sample weight in any given environment.
- *Min-S Alert* – Alerts user to ensures they are operating within USP41 compliance.

## Impact Shock Detection (ISD)

- *Impact-Alert* visually & audible indicates the magnitudes of impact shocks.
- *Shock-log* documents date, time, and shock level.

**Flow Rate Display (FRD)** streamline & improve filling or dosing accuracy & precision.

- *FR-Cal* calculates, displays/outputs the mass or volume flow rate by entering density.
- *FR-Compare* is a comparator which provides feedback if the flow rate is within limits.
- *FR-Secure* stores tare values in our non-volatile memory if application was disrupted.

## Good Data Management

**Internal Calibration** Easy one touch button performs & document internal calibration.

**Automatic Self-Calibration (ASC)** Auto calibrates based on temperature and time interval.

**Universal Flexi Coms (UFC)** edit serial data output making label printing possible.

**Password-Protect** offers password-protection up to 11 users and 1 administrator.

**GLP/GMP/GCP Compliance** outputs manufacturer, model, serial number, ID, date, time, signature for full calibration report.

## Practical Features

### Leveling Made Easy

- Plug in, turn on, screen blinks for 5 seconds to prompt user to level.
- *Bright-bubble* – Large, easy-to-see, front mounted spirit level with LED illumination.
- *Fly-thumbwheel* is effortless & accessible allows ergonomic adjustment with anti-slip feet.

### Simple User Interface

- *Six straightforward keys* – ON/OFF, CAL, MODE, SAMPLE, PRINT, REZERO.
- *Reverse Backlit LCD* is a large display with great B&W contrast provides excellent visibility.

### Cleanable Robust Construction

- *Stainless Steel Pan & Dust-plate* can be easily removed for cleaning .
- *Easy to assemble* anti-static breeze break on 0.001 readability models.
- *Die-cast Aluminum* housing provides extra stability and durability.

### Flexible Interface & Security

- *Standard RS-232C & USB* – Toggle between the Quick USB mode or Virtual COM mode (bi-directional). A USB cable comes standard.
- *Security Slot* – Anti-theft lock (such as Kensington) to prevent loss.



## KEY FEATURES:



Super Hybrid Sensor



GX-A Internal Calibration



ECL Electronically Controlled Load



ISD Impact Shock Detection



FRD Flow Rate Display



USB - Bidirectional



RS-232C



Universal Flexi Coms



Password Protect

## Specifications

GX-A Models Internal Calibration		GX 203A	GX 303A	GX 403A	GX 603A	GX 1003A	GX 1603A	GX 2002A	GX 3002A	GX 4002A	GX 6002A	GX 10002A	GX 6001A	GX 10001A	
Capacity		220 g	320 g	420 g	620 g	1100 g	1620 g	2200 g	3200 g	4200 g	6200 g	10200 g	6200 g	10200 g	
Readability		0.001 g						0.01 g						0.1 g	
Repeatability (std. deviation)		0.001 g					0.002 g   1600g 0.001 g   1000g		0.01 g				0.02 g   10kg 0.01 g   5kg		0.1 g
Linearity		±0.002 g			±0.003 g			±0.02 g			±0.03 g			±0.1 g	
Accuracy after internal calibration (GX-A series) <sup>i</sup>		± 0.010 g					± 0.010 g   1kg		± 0.10 g	± 0.15 g		± 0.15 g   5000 g		± 0.5 g   5000 g	
Stabilization Time		~ 1 sec (~0.8 sec for 5 g)					~1.5 sec (~0.8 sec   5 g)		~ 1 sec (~0.8 sec   50 g)			~ 1.5 sec (~0.8 sec   50 g)		~1 sec (~0.8 sec for 500 g)	
Sensitivity drift		±2 ppm / °C (10 °C to 30 °C / 50 °F to 86 °F, when automatic self-calibration is OFF)													
Calibration	Type	Internal													
	Wt. g.	50 g 100 g 200g	50 g 100 g 200 g 300 g	50 g 100 g (100 g interval) 400 g	50 g 100 g (100 g interval) 600 g	50 g 100 g (100 g interval) 1000 g	50 g 100 g (100 g interval) 1600 g	500 g 1000 g 2000g	500 g 1000 g 2000 g 3000 g	500 g 1000 g (1000 g interval) 4000 g	500 g 1000 g (1000 g interval) 6000 g	500 g 1000 g (1000 g interval) 10000 g	500 g 1000 g (1000 g interval) 10000 g	500 g 1000 g (1000 g interval) 6000 g	500 g 1000 g (1000 g interval) 10000 g
Display		Reverse Backlit LCD (Character height: 17.8 mm)													
Display Refresh Rate		5 times / second, 10 times / second or 20 times / second													
Units of Measure <sup>ii</sup>		g (gram), oz (ounces), lb (pound), lb-oz (pound-ounce), ozt (troy ounce), ct (metric carat), mom (momme), dwt (pennyweight), gr (grain), pcs (counting mode), % (percent mode), SG (specific gravity), and a user-programmable unit.													
Counting mode	Min unit mass	0.001 g						0.01 g						0.1 g	
	Number of samples	5, 10, 25, 50 or 100 pieces													
Percent mode	Min 100% ref mass	0.100 g						1.00 g						10.0 g	
	Min 100% display	0.01%, 0.1% or 1% (depends on the reference mass stored)													
Operating environment		5 °C to 40 °C / 41 °F to 104 °F, 85% R.H. or less (no condensation)													
Power supply / consumption		AC adapter / approx. 30 VA													
Communication Interface		Standard: RS-232C and USB Optional: Quick USB, LAN Ethernet (FXI-08), USB Host (GXA-24), Bluetooth Converters: AD-8529PC-W, AD8529PR-W													
Weighing pan size		128 mm × 128 mm / 5 × 5 in													
Dimensions (W × D × H)		212 (W) × 317 (D) × 93 (H) mm / 8.3 (W) × 12.5 (D) × 3.7 (H) in													
Net weight		Approx. 5 kg / 11 lb													
Weighing Applications		Counting with ACAI, % Weighing, Animal Weighing, Density Determination, Statistical Calculation, Comparator HI/OK/LO, Underhook, Gross/Net/Tare													
Options		Interfaces: GXA-03 2nd RS232, GXA-04 Comparator Relay, GXA-06 Analog output   External Key Input Interfaces: GXA-23-PRINT, GXA-23-REZERO, GXA-23-PLUG   Breeze Break: GXA-10 Large BB, GXA-17 Large BB with Ionizer   GXA-13 Density Kit, GXA-25 External Ionizer, GXA-26 External IR Switch, GXA-12 Animal Weigh Pan													
Accessories		TB247 Power Supply, AD-8127 Compact Printer, AD-1682 External Rechargeable Battery (for more accessories visit <a href="http://www.andweighing.com">www.andweighing.com</a> )													

<sup>i</sup> Under stable environment (no rapid temperature/humidity change, vibration, draft, magnetism, static, etc). The mass of the internal weight may vary with age.

<sup>ii</sup> One additional unit from tael (Singapore/HK jewelry/Taiwan/China), tola or Newton can be added upon request.

## Dimensions (mm/inch)

Models with readability of 0.01g and 0.1g

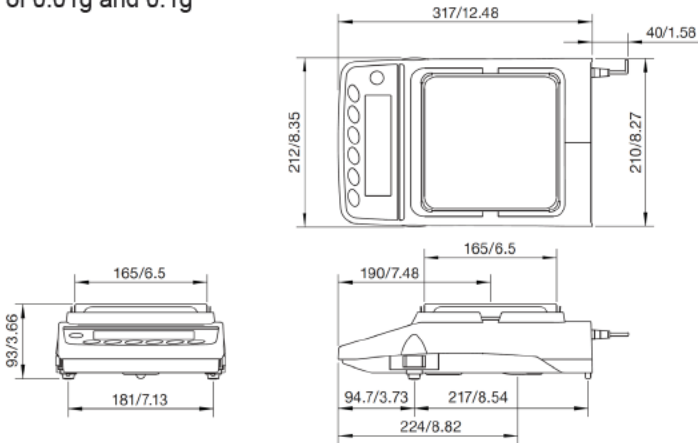

Models with readability of 0.001g

