



American Hakko Products, Inc.

PRODUCT BULLETIN

Bulletin No: PB486

Issue Date: 11-12-2024

Effective Date: 11-26-2024

Description/Title:

New CHP Hard Wire Shear

Part No:

CCS-30

Specification:

Part No.	CCS-30
Cut Type	Shear
Cutting Capacity	2.0mm \varnothing (12 AWG) ferrous wire 0.5mm \varnothing (24 AWG) steel wire
Material	C70 Steel
Steel Thickness	3.0mm (0.118 in.)
Overall Length	Approx. 136mm (5.4 in.)
Weight	78g (2.8 oz.)

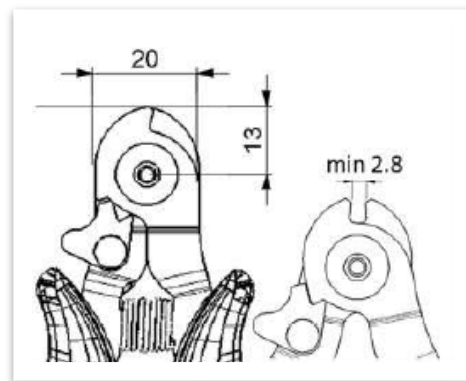

Comments:

The new CCS-30 Hard Wire Cutter is made from C70 steel that is quenched and tempered to harden the steel and features an anti-reflective and anti-oxidation surface treatment. The cutter is ideal for cutting not only copper and other soft metal wires but also ferrous wire, including memory wire. The cutter also features the ergonomic dolphin grip, which provides a comfortable anti-slip handle that reduces strain on the user's hand when cutting, and an integrated return spring to minimize hand fatigue.