



American Hakko Products, Inc.

# PRODUCT BULLETIN

**Bulletin No:** PB485

**Issue Date:** 11-12-2024

**Effective Date:** 11-26-2024

**Description/Title:**

New INOX Steel version TR-25 Cutter

**Part No:**

TR-25-X

**Specification:**

<b>Part No.</b>	TR-25-X
<b>Cut Type</b>	Flush
<b>Cutting Capacity</b>	1.3mm $\varnothing$ (16 AWG) copper wire
<b>Material</b>	INOX Steel
<b>Steel Thickness</b>	2.5mm (0.098 in.)
<b>Overall Length</b>	Approx. 138mm (5.4 in.)
<b>Weight</b>	75g (2.6 oz.)

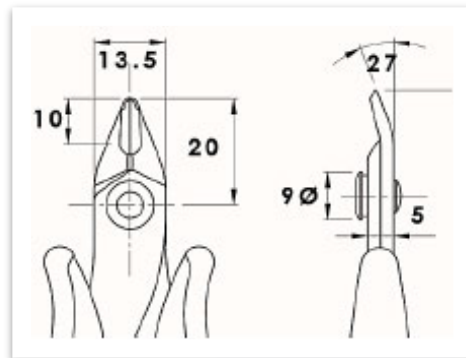

**Comments:**

The new TR-25-X cutter is made from a special high-quality INOX steel which undergoes a heat treatment in a controlled atmosphere and is well suited for use in cleanroom environments. The cutting edges have a hardness rating of approximately 54HRC, and the cutter features the ergonomic dolphin grip, which provides a comfortable anti-slip handle that reduces strain on the user's hand when cutting, and an integrated return spring to minimize hand fatigue. An ESD Safe version of the tool is available.

NOTE: This tool is not suitable for sterilization in an autoclave.