

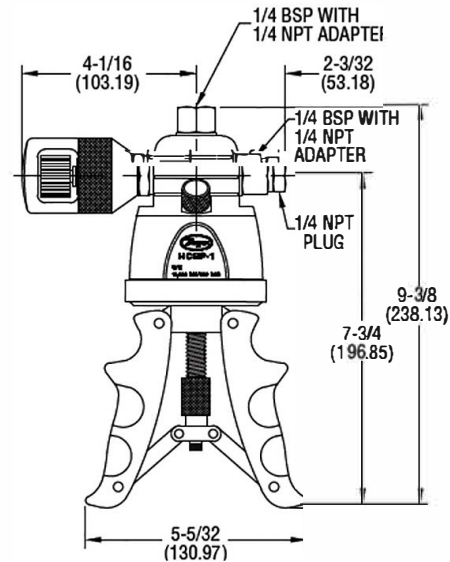

Series HCHP Hydraulic Calibration Hand Pump

Specifications - Installation and Operating Instructions



The Series HCHP Hydraulic Calibration Hand Pump utilizes a fully adjustable stroke control that allows for quick priming, easy pumping and fast pressure generation up to 10,000 psi (700 bar). The ergonomically engineered handles provide extra comfort, while the triple filtration system ensures pump operation in spite of dirty conditions. The shatterproof reservoir and stainless steel construction guarantee leak free operation. The Series HCHP has oversized check valves to provide smooth controlled operation.

SPECIFICATIONS

Output Ranges: 0 to 10000 psi (0 to 700 bar).

Process Connection: 1/4" NPT/BSP.

Gauge Connection: 1/4" NPT/BSP.

Materials: SS, polyurethane, anodized hard-coat aluminum, PTFE and nitrile.

Weight: 3 lb (1.36 kg).

INSTRUCTIONS



HIGH PRESSURE:

Uncontrolled release of high pressure is hazardous to personnel and may cause damage to equipment. Before connection of any pressure component to the HCHP ensure that the component(s) is/are isolated from the pressure source. Pressure built up internally during use can be extremely high, ensure that all connections are made correctly.

OPERATING INSTRUCTIONS

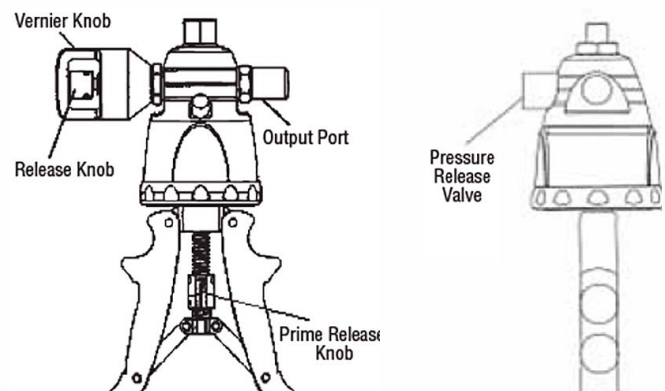

GUIDELINES FOR USE:

- Do not exceed 10,000 psi (700 bar) as this is the pumps maximum pressure.
- Each pump includes a built in pressure release valve to limit the maximum pressure. This is factory pre-set to 10,000 psi.
- The HCHP pump has 3/8" and 1/4" BSP ports. In order to use NPT fittings, the required NPT to BSP Parallel thread adapters need to be installed (Included BSP to 1/4" NPT Parallel Adapters).
- Do not use of thread sealant paste or tape on the adapters. To seal the adapters, simply hand tighten and snug up with a wrench. Do not over-tighten.
- Use with distilled water or mineral based hydraulic oil.
- Bonded washers are required to ensure proper seals.

PUMP OPERATION

1. Remove the filling plug and fill reservoir to the recommended level with the appropriate fluid and replace plug.
2. Connect hose fittings and calibrators to adapters.
3. Connect master instrument to pump via the top port.
4. Connect instrument under test to flexible hose/gage adapter.
5. To prime the system, twist the knurled knob marked "release". Squeeze the handles together and release. Twist the knob once again. Repeat as necessary until system is fully primed and low pressure is indicated on either the master or test instrument. This feature can be changed at any pressure.
6. Operate handle several times to build pressure. Please note, once pressure starts to rise, pressure can increase very rapidly. Warning: Do not exceed maximum operating pressure indicated on the pump label.
7. Careful uses of the release valve and fine control enable a controlled release of pressure, essential for calibration purposes.

To adjust the pressure relief valve, release the pressure and turn the valve counter clockwise 1/16 turn and then proceed to re-pressurize. Repeat the process if further reduction is necessary.

8. RESERVOIR FLUID LEVEL: If the fluid level in the reservoir falls considerably during use, a partial vacuum can be created in the reservoir which may affect the pump performance. To avoid this, simply allow air to enter the reservoir by partly unscrewing the filling plug.
9. SEAL REPLACEMENT: Dependent on the frequency of use, the Main Piston Seal (and others) will need replacing. Call factory for replacement seal.

MAINTENANCE

Upon final installation of the Series HCHP Hydraulic Calibration Hand Pump, no routine maintenance is required. A periodic check of system calibration is recommended. The Series HCHP is not field serviceable and should be returned if repair is needed (field repair should not be attempted and may void warranty). Be sure to include a brief description of the problem plus any relevant application notes. Contact customer service to receive a return goods authorization number before shipping.