

# LR8101

# LR8102

# HIOKI

## Instruction Manual

# DATA LOGGER



**Read carefully before use.**  
**Keep for future reference.**

**When using the instrument for the first time**

- Safety Information ▶ p.11
- Part Names and Functions ▶ p.30
- Settings and Operations ▶ p.77



**Troubleshooting**

- Maintenance and Service ▶ p.347
- Error Messages ▶ p.350

# EN





# Contents

|  |           |   |           |
|--|-----------|---|-----------|
| Introduction.....  | 7         | Wiring the CAN cable (LR8102 only) .....                          | 51        |
| Symbols and Abbreviations.....                           | 8         | Wiring the optical connection cable (LR8102 only).....            | 53        |
| Checking Package Contents.....                           | 10        | 2.6 Turning ON and OFF the Power .....                            | 55        |
| Options (sold separately) .....                          | 11        | 2.7 SD Memory Card and USB Drive .....                            | 56        |
| Safety Information .....                                 | 11        | Installing and removing an SD memory card.....                    | 58        |
| Usage Notes.....   | 13        | Installing and removing a USB drive .....                         | 59        |
| About This Manual.....                                   | 18        | 2.8 Setting and Connecting the LAN.....                           | 60        |
| Communication Method.....                                | 19        | Network settings on PC.....                                       | 63        |
| Command.....   | 19        | Connecting the instrument and a PC via LAN.....                   | 70        |
| Message format.....                                      | 20        | Default connection settings for LAN1 .....                        | 72        |
| Command syntax.....                                      | 21        | <b>3 Settings and Operations</b> .....                            | <b>77</b> |
| Header .....   | 21        | 3.1 Controlling the Instrument Using Communication Commands ..... | 77        |
| Message terminator .....                                 | 22        | Standard commands specified by IEEE 488.2.....                    | 78        |
| Separator .....  | 22        | 3.2 Basic Operations and Queries.....                             | 81        |
| Data part .....  | 23        | 3.3 Setting Measurement Conditions .....                          | 82        |
| Abbreviation of combined command header.....             | 25        | Normal sampling.....  | 82        |
| Output queue and input buffer.....                       | 26        | External sampling .....   | 85        |
| Register.....  | 26        | Common settings for the recording modes.....                      | 86        |
| Items to be initialized to the default status.....       | 28        | Set the synchronized terminal .....                               | 89        |
| <b>1 Overview</b> .....                                  | <b>29</b> | Data refresh interval of the measurement modules.....             | 90        |
| 1.1 Product Overview and Features.....                   | 29        | 3.4 Setting the Voltage/Temp Module .....                         | 94        |
| Both LR8101 and LR8102.....                              | 29        | Voltage measurement .....   | 94        |
| LR8102 only .....  | 29        | Temperature (thermocouple) measurement .....                      | 96        |
| 1.2 Part Names and Functions .....                       | 30        | 3.5 Configuring the Pulse Channel and Logic Channel Settings..... | 100       |
| LR8101 and LR8102 Data Loggers .....                     | 30        | Pulse aggregation.....  | 100       |
| 1.3 Options.....   | 33        | Rotation speed measurement .....                                  | 103       |
| Measurement modules.....                                 | 33        | Logic signal measurement .....                                    | 107       |
| Other options.....                                       | 34        | 3.6 Using the Scaling Function .....                              | 109       |
| 1.4 Measurement Workflow.....                            | 35        | 3.7 Entering Comments .....                                       | 115       |
| <b>2 Connection (Preparation for Measurements)</b> ..... | <b>37</b> | Title comment.....  | 115       |
| 2.1 Inspection Before Use .....                          | 37        | Channel comment.....  | 115       |
| 2.2 Connecting the Measurement Modules .....             | 38        | Module identification name.....                                   | 116       |
| 2.3 Connecting the AC adapter.....                       | 40        | 3.8 Performing Zero Adjustment .....                              | 117       |
| 2.4 Connecting an External Power Supply .....            | 41        | 3.9 Starting and Stopping Measurement .....                       | 118       |
| 2.5 Connecting Cables.....                               | 42        | Forcing termination of measurement .....                          | 119       |
| Wiring the voltage cable and thermocouple.....           | 44        | Handling of data exceeding the allowable measurement range.....   | 120       |
| Wiring for the pulse input.....                          | 47        | Measurement operation status change .....                         | 120       |
| Wiring for the alarm output.....                         | 48        | 3.10 Checking Measurement Start Time and Trigger Time.....        | 121       |
| Wiring for external control .....                        | 49        |   |           |
| Wiring for the external sampling .....                   | 50        |   |           |

1

2

3

4

5

6

7

8

9

10

Index

**4 Acquiring Measurement Data** 123

- 4.1 Acquiring Measurement Data on Internal Memory.....124
- 4.2 Acquiring Realtime Data.....127
- 4.3 Acquiring Hold Data .....129
- 4.4 Conversion of Measurement Data ...133
- 4.5 About Binary Data .....134
- 4.6 Text (Physical Value).....135
- 4.7 Comparison of Realtime Data Acquisition .....136

**5 Trigger Function** 137

- 5.1 Trigger Contents .....138
- 5.2 Enabling the Trigger Function.....139
  - Common settings.....139
- 5.3 Analog Trigger, Pulse Trigger, and Waveform Calculation Trigger .....143
  - Level trigger.....143
  - Window trigger.....147
- 5.4 Logic Trigger (Pattern).....152
- 5.5 Applying External Trigger .....153
- 5.6 Applying Triggers at Constant Intervals .....154
- 5.7 Applying Trigger Forcibly.....156
- 5.8 Trigger Setting Examples .....157

**6 Saving and Loading Data** 159

- 6.1 Savable and Loadable Data .....159
- 6.2 Formatting Media.....162
- 6.3 Saving Data.....163
  - Auto save (Realtime save) .....164
  - Manual save operation.....173
  - Common saving settings.....178
- 6.4 Loading Data.....180
  - Auto-setup function.....182
- 6.5 Organizing Data.....183

**7 Alarm (Alarm Output)** 185

- 7.1 Setting Alarms.....185
  - Alarm condition settings that apply to all channels.....185
  - Settings for each alarm channel .....189

- Alarm settings for each channel .....190
- 7.2 Checking Alarm.....203

**8 Marking Function** 205

- 8.1 Placing Event Marks During Measurement .....205
- 8.2 Placing Event Marks With External Signals .....206
- 8.3 Placing an Event Mark When an Alarm is Issued .....207
- 8.4 Checking Events in CSV Data.....208

**9 Numerical and Waveform Calculation** 209

- 9.1 Performing Numerical Calculation ...209
  - Setting the numerical calculations .....210
  - Numerical calculation formula .....216
- 9.2 Performing Waveform Calculations .218

**10 Setting System Environment** 225

- 10.1 Setting the Environment .....225
  - Start backup .....225
  - Language .....226
  - Date format .....226
  - Date delimiter .....227
  - Beep sound.....227
  - Horizontal (time) axis display.....228
- 10.2 Operating the System .....229
  - Time setting.....229
  - Time synchronization .....232
  - Initialization .....234
  - Self-checks (Self-diagnosis).....235
  - Operation clock checks.....238
  - Adjustment/calibration date checks .....239

**11 External Control (EXT. I/O)** 241

- 11.1 Setting the Alarm Output (ALARM)..241
- 11.2 Setting the External Input and Output (I/O) Terminals .....243
  - Starting multiple measurements simultaneously using the external trigger .247
- 11.3 Setting the External Sampling (SMPL).....248

## 12 Communication with PC (Computer) 249

- 12.1 Using Logger Utility .....249
- 12.2 Remotely Operating the Instrument through the HTTP Server .....251
  - Connecting to the HTTP server .....251
  - Starting and stopping measurement .....253
  - Displaying the measured value.....254
  - Comment entry .....255
  - Error/warning display .....256
  - LAN settings .....257
  - Remote upgrade .....258
  - Downloading A2L file .....259
  - Acquisition of setting file information .....260
  - Downloading Instruction Manual.....261
- 12.3 Acquiring Data with the FTP Server 262
- 12.4 Sending Data Using the FTP Client.264
  - Setting auto send .....270
  - File upload test .....275
  - FTP communication status check .....276
- 12.5 Sending Measurement Data Using XCP on Ethernet.....277
  - Setting the input channel.....277
  - Creating the A2L file.....278
  - Settings on ECU control software .....279
- 12.6 Outputting the Measured Value Using CAN.....280
- 12.7 Setting and Connecting LAN2 .....281
- 12.8 Outputting the Measured Value Using LAN2 .....285
  - Data format .....288
  - Conversion method from data in the INT32 format to physical quantities.....290
  - Measured value output function in synchronization.....290
  - Number of channels that can be output during each recording interval .....291

## 13 Specifications 293

- 13.1 Specifications of Data Logger.....293
  - General Specifications .....293
  - Recording.....298
  - File.....299
  - Calculation .....300
  - Trigger.....300
  - Alarm .....301
  - Pulse input, logic input .....301
  - Synchronous operation (LR8102 only).....302
  - Other functions .....303
  - Included accessories, options .....303

- 13.2 Specifications of Modules .....304
  - M7100 Voltage/Temp Module .....304
  - M7102 Voltage/Temp Module .....307

## 14 Knowledge and Information 313

- 14.1 Measuring Temperature.....313
- 14.2 Digital Filter Characteristics .....315
- 14.3 Noise Countermeasures.....316
  - Mechanism of noise mixing .....316
  - Examples of noise countermeasures .....318
- 14.4 Timing of Scan .....322
  - For M7100.....323
  - For M7102.....324
- 14.5 File Name .....325
- 14.6 File Configuration for Text Format...326
- 14.7 File Size .....328
- 14.8 Settings After Initialization (System Reset).....329
- 14.9 Maxi Recording Time .....331
- 14.10 Applied Measurement.....332
  - Recording of instrumentation signal (4-20 mA) .....332
  - Measurement of power consumption using pulse output of watt-hour meter .....334
- 14.11 Configuration of Input Circuit .....335
- 14.12 Data Handling .....336
  - Measurement data special values .....336
  - Calculation special values .....337
  - Special value for measured value output using LAN2.....338
  - Special value for measured value output using CAN .....338
- 14.13 Module-related Commands.....339
- 14.14 The Measured Data Realtime Output .....340
- 14.15 Command Samples.....341
- 14.16 File Name and Directory Name.....343
- 14.17 External View .....344
  - LR8101 .....344
  - LR8102 .....344
  - M7100 .....345
  - M7102 .....345
  - 6 units of M7100 are connected .....346
  - 10 units of M7100 are connected.....346

1

2

3

4

5

6

7

8

9

10

Index

|           |                                  |     |
|-----------|----------------------------------|-----|
| <b>15</b> | <b>Maintenance and Service</b>   | 347 |
| 15.1      | Repair, Correction, and Cleaning | 347 |
| 15.2      | Troubleshooting                  | 349 |
|           | Before returning for repair      | 349 |
|           | Error messages                   | 350 |
|           | Normalization process            | 356 |
| 15.3      | Disposal                         | 357 |
| 15.4      | FAQ (Frequently Asked Questions) | 359 |
| 15.5      | Open-source Software             | 361 |

# Introduction

Thank you for choosing the HIOKI LR8101/LR8102 Data Logger. To obtain maximum performance from this instrument over the long term, please read this manual carefully and keep it available for future reference.

The LR8102 Data Logger is a model based on the LR8101 with additional functions as follows.

- Function to synchronize sampling between instruments
- Function to output measured values from LAN2 port
- Function to output measured values from CAN port

## The latest edition of the instruction manual

The contents of this manual are subject to change, for example as a result of product improvements or changes to specifications.

The latest edition can be downloaded from Hioki's website.

<https://www.hioki.com/global/support/download/>



## Product registration

Register your product in order to receive important product information.

<https://www.hioki.com/global/support/myhioki/registration/>



The following instruction manuals are provided. Refer to the appropriate manual for your specific application.

Before using the instrument, make sure to carefully read the separate document titled "Operating Precautions".

| Type   | Description   | Printed version | DVD version |
|--|---|-----------------|-------------|
| Operating Precautions                                  | Information for using the instrument safely   | ✓               | –           |
| Startup guide  | Operating precautions, connection method, and basic operations                            | ✓               | ✓           |
| Instruction Manual (this manual)                       | Detailed descriptions, specifications, and information about the functions and operations | –               | ✓           |
| Logger Utility* <sup>1</sup> Instruction Manual        | How to install and operate the PC application software                                    | –               | ✓           |
| Communication Command* <sup>2</sup> Instruction Manual | Descriptions about the communication commands for controlling the instrument              | –               | ✓           |

\*1. For how to install and operate the PC application software, "Logger Utility", refer to "Logger Utility Instruction Manual" found on the provided DVD (Application Disc).

\*2. The instrument can be controlled with a PC connected via a LAN.

For information on the communication commands to control the instrument, refer to the "Communication Command Instruction Manual" found on the provided DVD (Application Disc).

## Target audience

This manual has been written for use by individuals who use the product or provide information about how to use the product.

In explaining how to use the product, it assumes electrical knowledge (equivalent of the knowledge possessed by a graduate of an electrical program at a technical high school).







## Trademarks

- Excel, Microsoft, Microsoft Edge, Visual Basic, and Windows are trademarks of the Microsoft group of companies.
- SD and the SDHC logos are trademarks of SD-3C LLC.
- Intel, the Intel logo, and Intel Core are trademarks of Intel Corporation or its subsidiaries.







# Symbols and Abbreviations

## Safety

In this manual, the risk levels are classified as follows.



|  |  |
|--|--|
|  <b>DANGER</b>  | Indicates an imminently hazardous situation that, if not avoided, will result in serious injury or death.  |
|  <b>WARNING</b> | Indicates a potentially hazardous situation that, if not avoided, could result in serious injury or death.   |
|  <b>CAUTION</b> | Indicates a potentially hazardous situation that could result in minor or moderate injury, or potential risks of damage to the supported product (or to other property), if not avoided. |
| <b>IMPORTANT</b>   | Indicates information related to the operation of the instrument or maintenance tasks with which the operators must be fully familiar.   |
|                | Indicates a high-voltage hazard. Failure to verify safety or improper handling of the instrument could lead to an electric shock, burn, or death.  |
|               | Indicates prohibited actions.  |
|               | Indicates an action that must be performed.  |

## Symbols on the product

|   |  |
|---|--|
|  | Indicates the presence of a potential hazard.<br>For more information about locations where this symbol appears on instrument components, see “Usage Notes” (p. 13) of the Instruction Manual, warning messages listed at the beginning of each set of operating instructions, and the accompanying document entitled “Operating Precautions”. |
|  | Indicates that the entire device is protected with double or reinforced insulation.  |
|  | Indicates the power push-button switch that toggles the instrument between on and off.   |
|  | Indicates a grounding terminal.  |
|  | Indicates DC (Direct Current).   |
|  | Indicates alternating current (AC).  |



### Symbols for various standards

|   |   |
|---|---|
|  | <p>Indicates that the product complies with standards imposed by EU directives.</p>   |
|  | <p>Indicates that the product is subject to the Waste Electrical and Electronic Equipment (WEEE) Directive in EU member nations. Dispose of the product in accordance with local regulations.</p> |

### Others

|   |   |
|---|---|
|  | <p>Indicates convenient functions and advice that are useful to know.</p>   |
| <p>*</p>  | <p>Indicates additional information is provided below.</p>  |
| <p><input checked="" type="checkbox"/></p>  | <p>Indicates the default setting value. Initialization resets the setting to this value.</p>  |
| <p>(p. )</p>  | <p>Indicates the page number to refer to.</p>   |
| <p><b>Bold letters</b></p>  | <p>Indicates the names of the elements and the keys on the screen.</p>  |
| <p>[ ]</p>  | <p>Indicates the names of user interface elements on the screen.</p>  |
| <p>Windows</p>  | <p>Unless otherwise noted, the term “Windows” is used generically to refer to Windows 7, Windows 8, Windows 10, and Windows 11.</p>   |
| <p>S/s</p>  | <p>For this instrument, the number of times the analog input signal is digitized is indicated in samples per second (S/s).<br/>Example: 20 MS/s (20 megasamples per second) signifies <math>20 \times 10^6</math> samples per second.</p> |

### Accuracy labeling

The instrument accuracy is expressed by defining a limit value for errors in terms of the same unit as the measured value.

# Checking Package Contents

When you receive the instrument, inspect it to ensure that no damage occurred during shipment. If you find any damage or discover that the instrument does not perform as indicated in its specifications, please contact your authorized Hioki distributor or reseller.

## Check the package contents as follows.

### Instrument

- LR8101 Data Logger

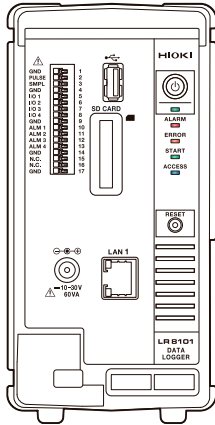

- LR8102 Data Logger

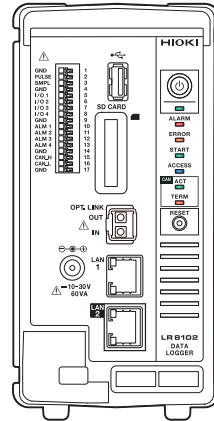

### Included accessories

- Operating Precautions (0990A903)



- Startup Guide



- Logger Application Disc (DVD) \*1
  - Startup Guide
  - Instruction Manual
  - Logger Utility
  - Logger Utility Instruction Manual
  - CAN Editor
  - CAN Editor Instruction Manual
  - Communication Command Instruction Manual
  - GENNECT One

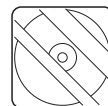

\*1. The latest edition can be downloaded from the Hioki website.

## Options (sold separately)

The options listed below are available for the instrument. See “1.3 Options” (p. 33).  
To place orders, contact your authorized Hioki distributor or reseller.  
Options are subject to change. Check Hioki’s website for the latest information.

|       |   |
|-------|---|
| M7100 | Voltage/Temp Module (15 channels)                 |
| M7102 | Voltage/Temp Module (30 channels)                 |
| Z1016 | AC Adapter (2-pole grounding power cord included) |
| L1012 | Power Cable (with unprocessed ends)               |
| Z4001 | SD Memory Card (2 GB)                             |
| Z4003 | SD Memory Card (8 GB)                             |
| Z4006 | USB Drive (16 GB)                                 |
| 9642  | LAN cable   |
| L6101 | Optical Connection Cable (1 m)                    |
| L6102 | Optical Connection Cable (10 m)                   |

## Safety Information

The instrument and measurement modules are designed in accordance with IEC 61010 International Standards, and have been thoroughly tested for safety prior to shipment. However, failure to follow the guidelines outlined in this manual may compromise the safety of the instrument. Before using the instrument and measurement modules, make sure to read the following safety precautions carefully.

### DANGER

- **Read the Instruction Manual carefully and ensure you understand its contents before using the instrument.**



Improper use of the instrument could result in serious bodily injury or damage to the instrument.

### WARNING

- **When using the electric measuring instrument for the first time, perform the measurement under supervision of experienced personnel.**

Failure to do so could cause the operator to experience an electric shock.

In addition, heat generation, fire, arc discharge due to short circuit, or other problems could occur.



- **Wear insulating protective equipment.**

This instrument measures live lines. Failure to wear the protective equipment could cause the operator to experience an electric shock. It is stipulated in the law that insulating protective equipment must be worn.

## Measurement categories

IEC 61010 defines measurement categories to facilitate safe use of measuring instruments. Test and measurement circuits designed to be connected to a main power supply are classified into three categories depending on the type of main power supply circuit.

### ⚠ DANGER

- **Do not use the measuring instrument to measure a main power supply circuit that exceeds the instrument's specified measurement category.**



- **Do not use a measuring instrument without a specified measurement category to measure a main power supply circuit.**

Doing so may result in serious bodily injury or damage to the instrument or other equipment.

**Measurement category II (CAT II)**     Applicable to test and measuring circuits connected directly to utilization points (socket outlets and similar points) of a low-voltage MAINS installation.  
 Example: Measurements on household appliances, portable tools, and similar equipment, and on the consumer side only of socket outlets in the fixed installation.

**Measurement category III (CAT III)**     Applicable to test and measuring circuits connected to the distribution part of the a building's low-voltage MAINS installation.  
 Example: Measurements on distribution boards (including secondary meters), photovoltaic panels, circuit breakers, wiring, including cables, bus-bars, junction boxes, switches, and socket outlets in a fixed installation, as well as equipment for industrial use and some other equipment such as stationary motors with permanent connection to the fixed installation.

**Measurement category IV (CAT IV)**     Applicable to test and measuring circuits connected at the source of the a building's low-voltage MAINS installation.  
 Example: Measurements on devices installed before the main fuse or circuit breaker in the building installation.

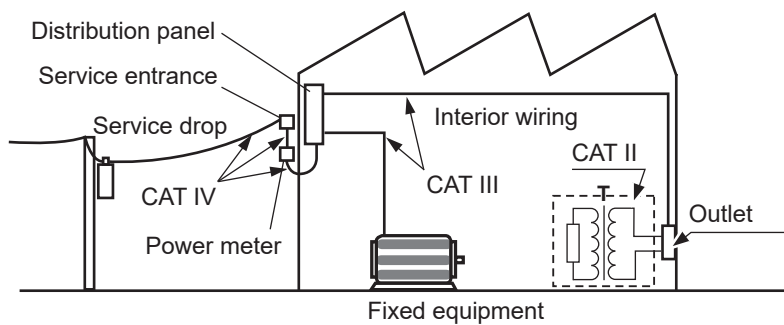

## Usage Notes

Be sure to follow the precautions listed below in order to use the instrument safely and in a manner that allows it to function effectively.

Use of the instrument should conform not only to its specifications, but also to the specifications of all accessories, options, and other equipment in use.

### Check before use

#### **DANGER**

- **Inspect the instrument and verify proper operation before use.**



Use of the instrument while it is malfunctioning could result in serious bodily injury. If you find any malfunction or damage, contact your authorized Hioki distributor or reseller.

See “2.1 Inspection Before Use” (p. 37) for information about inspections.

### Installing the instrument

#### **WARNING**

- **Do not install the instrument in the following types of locations:**

- Locations exposed to direct sunlight or high temperatures
- Areas where corrosive or explosive gases are present
- Near sources of strong electromagnetic fields or electrostatic charges
- Close to induction heating systems (such as high-frequency induction heaters or IH cookers)
- Locations subject to mechanical vibrations
- Places where the instrument could be exposed to water, oil, chemicals, or solvents
- High-humidity areas or places where condensation occurs
- Dusty environments



Doing so could damage the instrument or cause it to malfunction, resulting in bodily injury.

- **Leave sufficient space around the instrument, so that the power cord can be unplugged.**



Without sufficient space around the instrument, the power supply cannot be shut down immediately in emergency situations. Failure to do so may result in bodily injury, fire, or damage to the instrument.

#### **CAUTION**

- **Do not place the instrument on an unstable stand or angled surface.**

Doing so could cause the instrument to fall or overturn, resulting in bodily injury or damage to the instrument.



- **Do not bend or pull the cables in environments below 0°C.**

The cables become stiff in such an conditions. Bending or pulling the cables may result in cable breakage or damaged insulation, posing a risk of electric shock to the operator.

## ⚠ CAUTION



- **Do not unplug the communication cable while the instrument is sending or receiving data.**

Doing so could damage the instrument.



- **Turn OFF the instrument and PC before connecting or disconnecting the communication cable.**

Failure to do so could damage the instrument being connected or cause it to malfunction.

- **Use the same ground for the instrument and the PC.**

When a communication cable is connected to the instrument with a potential difference between the ground circuits of the instrument and the PC, the instrument may be damaged or malfunction.

### IMPORTANT

- Take appropriate measures to prevent the ambient temperature near the terminal block of the measurement module from changing. If the terminal block is exposed to air from a ventilation fan, air conditioner, etc., a measurement error can occur during temperature measurement using a thermocouple.
- When the environment temperature has changed significantly, wait for at least 60 minutes before starting the measurement after the temperature is stabilized.

- Do not block the vents. (Leave at least 3 cm of space on the top and right sides to keep the instrument's temperature from rising.)
- Do not stack the instruments.

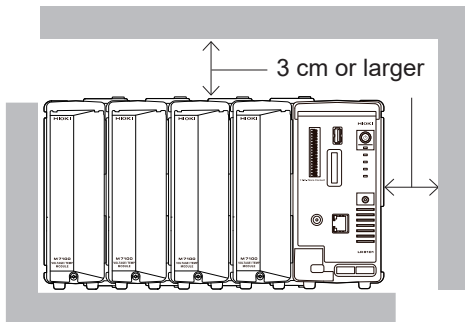

## Handling the instrument

### ⚠ CAUTION



- **Do not subject the instrument to vibration or mechanical shock while transporting or handling it.**

- **Do not drop the instrument on the floor or other surfaces.**

Doing so could damage the instrument.

The instrument is classified as a Class A device under the EN 61326 standard. Use of the instrument in a residential setting such as a neighborhood could interfere with reception of radio and television broadcasts. In such cases, the operator should take appropriate measures to address the issue.

## Precautions for measurement

### **⚠ DANGER**

- Do not input voltage between the channels that exceeds the maximum input voltage of the measurement module, the maximum rated line-to-ground voltage, the maximum rated voltage between channels, or the maximum rated voltage between modules.



- **Maximum input voltage:** Between the + and – inputs
- **Maximum voltage between the channels:** Between any channels of the same module
- **Maximum rated line-to-ground voltage:** Between ground potential and the input terminals
- **Maximum rated voltage between the modules:** Between channels of different modules

Doing so could result in serious bodily injury or damage to the instrument. These rated voltages vary depending on the measurement modules. See “13 Specifications” (p.293) for these values.

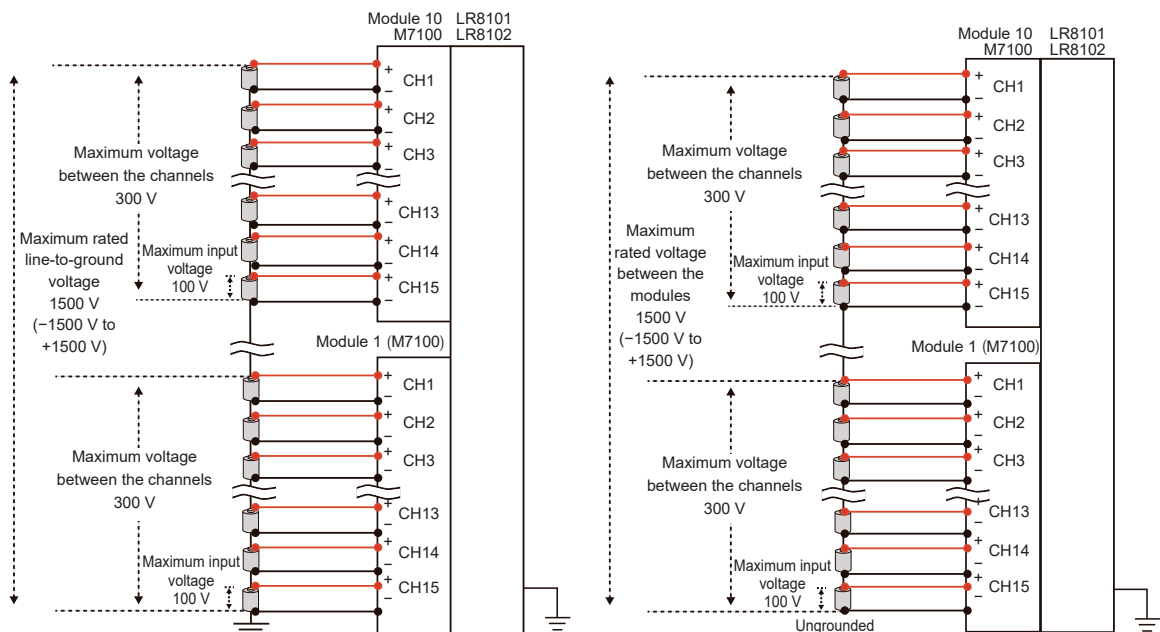

If you use modules with differing maximum rated voltages between modules for a measurement target connected in series, such as a battery pack, the specifications of the module with the lower maximum rated voltage between modules will apply.

Example: Mixing M7100 and M7102 to measure a battery pack

This combination cannot be used to measure a battery pack over 600 V, because the maximum input voltage between the modules is limited to 600 V DC.



#### **Supplementary explanation about maximum voltage between the channels**

When the maximum voltage between the channels is 300 V, make sure that the potential difference between the adjacent channels, as well as among all the channels, is within 300 V. For example, the potential difference should be within 300 V between CH1 and CH2, and also between CH1 and CH15.

## ⚠ DANGER

- **Do not use the instrument to measure circuits that exceed the ratings or specifications of the instrument.**

Doing so could cause damage to the instrument or overheating, resulting in serious bodily injury.



- **Do not use the instrument and measurement modules to measure a main power supply circuit.**

The voltages to earth of the M7100 and M7102 measurement modules are compatible with CAT II. However, these modules cannot be used for a measurement in CAT II, CAT III, or CAT IV.

Never input a voltage in CAT II, CAT III, or CAT IV between the measurement terminals.

Failure to do so could cause the operator to experience an electric shock or damage the instrument.

## ⚠ WARNING

- **Do not allow the instrument to become wet.**



- **Do not operate the instrument with wet hands.**

Doing so could cause the operator to experience an electric shock.

- **Securely connect the measurement cables to the input terminals.**

Loose terminals could result in increased contact resistance, causing the product to become hot or burn up or resulting in bodily injury or fire.



- **When no measurement module is connected, install the connector cover.**

Failure to do so could cause the operator to experience an electric shock or damage the instrument and measurement modules.



### **Effect of induced voltage**

Due to induced voltage, the displayed value may become unstable when there is no input; however, this is not a malfunction.

A physical phenomenon called short range ordering occurs in K and T thermocouples. This phenomenon may prevent accurate measurement between 250°C and 600°C.

Select the sensor while referring to the manufacturer of the thermocouples to be used.



## Shipping Precautions

- Store the packing materials after unpacking. When shipping the instrument, use the original packing materials that were used when the instrument was delivered.
- To ship the instrument safely, use the box and cushioning material in which it was originally shipped. However, do not use the original box or cushioning material if the box is torn or deformed or the material is crushed. If you are unable to use the original box and cushioning material, contact your authorized Hioki distributor or reseller.
- Before packing the instrument, be sure to disconnect the power cords.
- When transporting the instrument, exercise care to avoid dropping it or otherwise subjecting it to rough handling.

## Precautions related to disc usage

- Exercise care to keep the recording surface of the disc free of dirt and damage.
- If you need to label the disc, for example with text, use a marker with a soft tip.
- Store discs in protective cases. Avoid exposing the disc to direct sunlight, high temperatures, or high humidity.
- We are not responsible for any issues that may arise in your computer system due to the use of this disc.

# About This Manual

## 5 Set whether or not to repeat the recording operation.

The command is required for the setting.  
 Sending the command as shown in the example will update the settings on the instrument.

The command is required for inquiring about the setting.  
 Sending the command as shown in the example allows you to acquire the setting and measured value in the (Response) format.

Setting item and description  
 The configurable item and its description.

| Settings             |   |                   |
|----------------------|---|-------------------|
| Syntax               | Command   | :TRIGger:MODE A\$ |
| Example              | :TRIGger:MODE REPEat  |                   |
| Query                |   |                   |
| Syntax               | Query   | :TRIGger:MODE?    |
|                      | Response  | A\$               |
| Example              | :TRIGger:MODE?<br>(Response) :TRIGGER:MODE REPEAT (When the header is ON)                                 |                   |
| Parameter            |   |                   |
| A\$ = SINGle, REPEat |   |                   |
| SINGle <sup>Ⓜ</sup>  | Repetitive recording OFF<br>The measurement is completed with one recording.                              |                   |
| REPEat               | Repetitive recording ON<br>The recording is repeated.<br>Executing the STOP command ends the measurement. |                   |

# Communication Method

## Command

Various communication commands are available to control the instrument via the interface. The communication commands include the program messages, which are sent from a PC to the instrument, and the response messages, which are sent from the instrument to a PC.

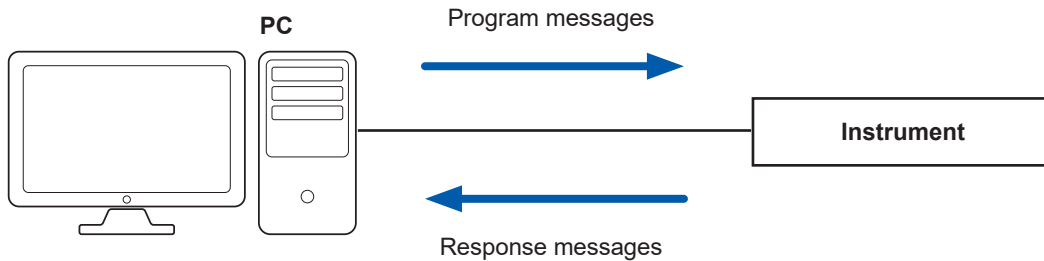

The data sent and received between communication devices is referred to as a message. The messages are categorized as shown in the figure below.

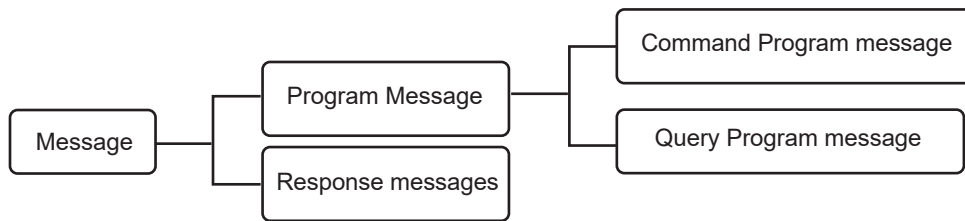

|                                 |  |
|---------------------------------|--|
| <b>Program messages</b>         | These messages are sent from the controller to the instrument.   |
| <b>Response messages</b>        | These messages are sent from the instrument to the controller. The message is created after a query program message is received and its syntax is checked. |
| <b>Command program messages</b> | These messages are the commands to control the instrument, such as setting or resetting the instrument.  |
| <b>Query program messages</b>   | These messages are the commands to query the results of operations, measurements, and the setting status of the instrument.                                |

The command program messages and the query program messages are collectively referred to as the commands. (The commands are written in Hioki's proprietary SCPI language.)

## Message format

---

### Program messages

The program messages can be categorized into command program messages and query program messages.

#### (1) Command program messages

Commands to control the instrument, such as setting or resetting the instrument

Example: Command to set the measurement frequency

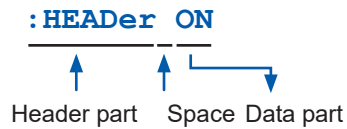

#### (2) Query program messages

Commands to query the results of operations, measurements, and the setting status of the instrument

Example: Command to query the current measurement frequency

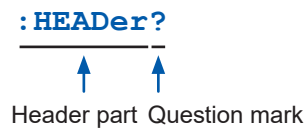

See “Header” (p. 21), “Separator” (p. 22), and “Data part” (p. 23).

### Response messages

The response message is created after a query message is received and its syntax is checked. If any error occurs when a query message is received, no response message is created for the query message.

## Command syntax

There are two command description formats as follows:

- Long form that can be associated with functions
- Abbreviated short form

In this manual, the short-form part is written in uppercase, while the remaining part is written in lowercase. Commands with both uppercase and lowercase letters are accepted.

|  |                             |
|--|-----------------------------|
| <code>:SYSTem:COMMunicate:LAN:IPADdress</code> | Description in this manual  |
| <code>:SYSTEM:COMMUNICATE:LAN:IPADDRESS</code> | OK (long form)              |
| <code>:SYST:COMM:LAN:IPAD</code>               | OK (short form)             |
| <code>:SYST:COMM:LAN:IPADD</code>              | Results in a command error. |
| <code>:SYST:COMM:LAN:IPA</code>                | Results in a command error. |

The response messages from the instrument are returned in the long form with uppercase letters.

## Header

The program messages require a header.

### (1) Command program headers

There are the following three types:

| Command type            | Example                              | Description   |
|-------------------------|--------------------------------------|---|
| Single command header   | <code>:HEADer ON</code>              | Header that consists of a single word starting with an alphabetical character                               |
| Combined command header | <code>:SYSTem:DATE<br/>24,1,2</code> | Header that consists of multiple single command headers separated with colons (:)                           |
| Standard command header | <code>*RST</code>                    | Header that starts with an asterisk (*) indicating the standard command header (as specified in IEEE 488.2) |

### (2) Query program header

This header is used to query the setting status of the instrument or query the measured values.

As shown in an example below, a program header ending with a question mark (?) is recognized as a query.

| Command type            | Example                    | Description   |
|-------------------------|----------------------------|---|
| Single command header   | <code>:HEADer?</code>      | Header that consists of a single word starting with an alphabetical character                               |
| Combined command header | <code>:SYSTem:DATE?</code> | Header that consists of multiple single command headers separated with colons (:)                           |
| Standard command header | <code>*IDN?</code>         | Header that starts with an asterisk (*) indicating the standard command header (as specified in IEEE 488.2) |

## Message terminator

The instrument can accept the following as a message terminator.

|      |           |
|------|-----------|
| LAN1 | LF, CR+LF |
|------|-----------|

The terminator for response messages is fixed to CR+LF.

## Separator

### (1) Message unit separator

Multiple message can be described in a single line by connecting them using semicolons (;).

Example: `:HEADer ON;*OPC?`

↑  
Semicolon

If a series of messages is described continuously and an error occurs in the sentence, the messages after the error and before the terminator are not executed.

### (2) Header separator

A message with a header and data can be separated into the header and data parts by using a space (blank).

Example: `:HEADer ON`

↑  
Space

### (3) Data separator

A message with multiple data sets requires commas (,) between the data sets.

Example: `:SYSTem:COMMunicate:LAN:IPADdress 192,168,1,1`

↑  
Comma

## Data part

The instrument uses the character data or the decimal numerical value data for the data part depending on the commands.

The data field is expressed as follows.

| Symbol      | Meaning                           | Example   |
|-------------|-----------------------------------|---|
| A\$         | Character string data             | OFF, ON   |
| module\$    | Module data                       | MODULE1 to MODULE10<br>PLS&ALM, CALC1 to CALC2                                      |
| ch\$        | Channel data                      | CH1_1 to CH10_30<br>PLS1<br>LOG<br>ALM1 to ALM4<br>ALARM* <sup>1</sup><br>W1 to W30 |
| pls\$       | Pulse channel data                | PLS1  |
| alm\$       | Alarm channel data                | ALM1 to ALM4  |
| w\$         | Waveform calculation channel data | W1 to W30   |
| A, B, C,... | Numerical value data              | 10, -20, 1.5E+05, 0.1   |
| A<NR1>      | Integral number data              | +15, -20, 25  |
| A<NR2>      | Fixed-point data                  | +1.23, -4.57, 7.89  |
| A<NR3>      | Floating-point data               | +10.0E-03, -2.3E+03, 5E+03  |

For the settings of numerical values, all of the <NR1 to 3> formats are accepted.

\*1. The alarm function itself is the target.

### (1) Character data

The data always starts with an alphabetical character and consists of alphabetical and numerical characters. For the character data, both uppercase and lowercase letters are accepted. However, the response messages from the instrument are always returned with uppercase letters. As with the command syntax, the long and short forms are available and both are accepted.

Example: `:TRIGger:MODE SINGLE`

### (2) Decimal numerical value data

For the numerical value data, the NR1, NR2, and NR3 formats are available. Each format can accept numerical values with and without a sign. Numerical values without a sign are treated as positive numerical values.

In addition, if a numerical value is described to a decimal place that cannot be processed by the instrument, the value is rounded off to the next higher decimal place.

- NR1 integral number data (example: +12, -23, 34)
- NR2 decimal fraction data (example: +1.23, -23.45, 3.456)
- NR3 floating-point exponential notation data (example: +1.0E-2, -2.3E+4)

The format including all of the three formats above is referred to as the "NRf" format.

The instrument can accept numerical values in the NRf format.  
 The response data are sent in the format specified for each command.

```
Example of NR1 format:  :SYSTem:THINOut 10
Example of NR2 format:  :CONFIgure:SAMPle 0.1
Example of NR3 format:  :ALARm:ANALog:LEVEL ALM1,CH1_1,+1.0E-3
```

**(3) Character string data**

- The character string data are placed between quotation marks.
- The data consists of 8-bit ASCII characters. However, some commands including the comment setting are sent and received in Shift\_JIS.
- A character that cannot be processed with the instrument is replaced with an underscore (\_).
- As quotation marks, only double quotations (") can be sent. However, both double and single quotations (') can be received.
- In the commands, a single quotation (') can be used instead of a double quotation (").

The special characters can be entered as follows.

|                |    |    |    |    |    |    |    |    |    |    |    |
|----------------|----|----|----|----|----|----|----|----|----|----|----|
| PC             | ^2 | ^3 | ~u | ~o | ~e | ~c | ~+ | ~, | ~; | ^^ | ~~ |
| LR8101, LR8102 | 2  | 3  | μ  | Ω  | ε  | °  | ±  | '  | "  | ^  | ~  |

```
Example:  :COMMeNt:TITLe 'HIOKI '
          :COMMeNt:TITLe "HIOKI"
          :COMMeNt:TITLe "~o"
```



## Abbreviation of combined command header

When the commands with a common leading part are combined, the repeated part can be omitted as long as the commands are described continuously. This common part is referred to as a “current path”. Until the current path is cleared, the subsequent commands are analyzed assuming that the current path is omitted.

An example of using the current path is shown below.

|   |
|---|
| <p>Normal notation</p> <pre><code>:SYSTem:COMMunicate:LAN:IPADdress 192,168,1,1;:SYSTem:COMMunicate:LAN:SMASK 255,255,255,0</code></pre>  |
| <p>Abbreviated notation</p> <pre><code>:SYSTem:COMMunicate:LAN:IPADdress 192,168,1,1;SMASK 255,255,255,0</code></pre> <p>↑<br/>This part defines a current path, which can be omitted in the subsequent commands.</p> |

The current path is cleared under the following situations.

- When the power is turned ON
- When a command starting with a colon (:) or an asterisk (\*) is sent
- When a message terminator is detected

The single and combined command headers require no colon (:) at the beginning. However, it is recommended to place a colon (:) at the beginning of a command in order to prevent confusion with abbreviated forms and avoid malfunction.

## Output queue and input buffer

### (1) Output queue

The size of an output queue is 200 kilobytes.

The response messages are stored here and read out from the controller.

A response message exceeding 200 kilobytes results in a query error.

The output queue is cleared under the following situations.

- When the controller has read out a response message
- When the power is turned ON again
- When the instrument has received a message about the next target for processing.

### (2) Input buffer

The size of an input buffer is 200 kilobytes.

Received messages are input in this buffer and executed sequentially.

However, the **:ABORT** command is executed immediately when received.

## Register

The instrument is equipped with the following registers specified in IEEE 488.2 as shown in the figure below.

- Standard Event Status Register
- Status Byte Register
- Event Status Register 0

Event Status Register 0 (read out with **:ESR0?**)



Standard Event Status Register (read out with **\*ESR?**)

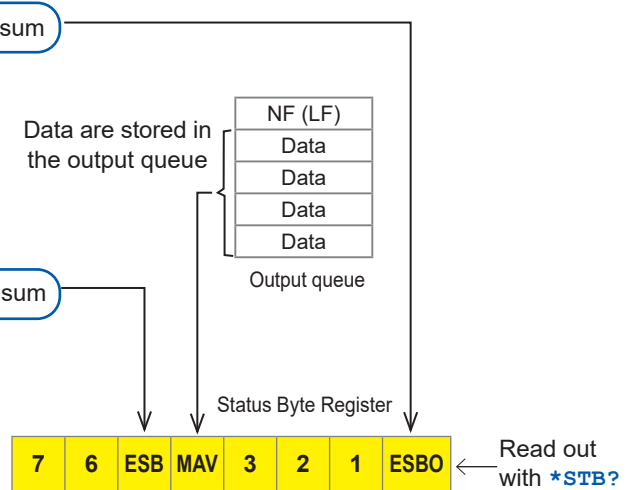

**(1) Status byte**

Each bit of the status byte is a summary (logical sum) of the event register corresponding to the bit.

| Status Bar      | Description  |
|-----------------|--|
| Bit 7           | Unused: 0  |
| Bit 6           | Unused: 0  |
| Bit 5<br>(ESB)  | Event summary bit<br>Represents a summary of the Standard Event Status Register. |
| Bit 4<br>(MAV)  | Message available<br>Indicates that there is a message in the output queue.      |
| Bit 3           | Unused: 0  |
| Bit 2           | Unused: 0  |
| Bit 1           | Unused: 0  |
| Bit 0<br>(ESB0) | Event summary bit 0<br>Represents a summary of Event Status Register 0           |

To read out the status byte, use the following command.

|                             |              |
|-----------------------------|--------------|
| Reading out the status byte | <b>*STB?</b> |
|-----------------------------|--------------|

**(2) Standard Event Status Register (SESR)**

The summary of this register is set on bit 5 of the status byte.

The contents of the Standard Event Status Register is cleared under the following situations.

- When the **\*CLS** command is received
- When the content has been read out with the **:ESR?** query
- When the power is turned ON again

| Standard Event Status Register (SESR) | Description  |
|---------------------------------------|--|
| Bit 7<br>(PON)                        | The power is turned ON again.<br>The power has been shut down after this register was read out for the last time. 1 when the power is turned ON. |
| Bit 6<br>(URQ)                        | User request<br>Unused (0)   |
| Bit 5<br>(CME)                        | Command error<br>The received command contains an error. Syntax error, semantic error.   |
| Bit 4<br>(EXE)                        | Execution error<br>The command being executed by the instrument contains an error.<br>Range error, mode error.                                   |
| Bit 3<br>(DDE)                        | Device dependent error<br>Unused (0)   |
| Bit 2<br>(QYE)                        | Query error<br>Empty queue, lost data (queue overflow)   |
| Bit 1<br>(RQC)                        | Request of controller privilege (unused)<br>Unused (0)   |
| Bit 0<br>(OPC)                        | Operation completed<br>Set only for the <b>*OPC</b> command.   |

To read out the Standard Event Status Register, use the following command.

|                                |              |
|--------------------------------|--------------|
| Standard Event Status Register | <b>*ESR?</b> |
|--------------------------------|--------------|

### (3) Event Status Register 0 (ESR0)

The summary of this register is set on bit 0 of the status byte.

The contents of the Event Status Register is cleared under the following situations.

- When the \*CLS command is received
- When the content has been read out with the :ESR0? query
- When the power is turned ON again

| Event Status Register 0 (SESR0) | Description   |
|---------------------------------|---|
| Bit 7                           | Unused: 0   |
| Bit 6                           | Unused: 0   |
| Bit 5                           | Unused: 0   |
| Bit 4                           | Unused: 0   |
| Bit 3                           | Unused: 0   |
| Bit 2                           | Trigger standby end (set when the trigger is activated) |
| Bit 1                           | START process end (set when STOP is executed)           |
| Bit 0                           | Error or warning occurred                               |

To read out the status byte, use the following command.

|                                   |        |
|-----------------------------------|--------|
| Reading out Event Status Register | :ESR0? |
|-----------------------------------|--------|

## Items to be initialized to the default status

The following items are initialized to the default status when the instrument is initialized.

For the initialization of the device-specific functions, see “14.8 Settings After Initialization (System Reset)” (p. 329).

✓: Initialized, –: Not initialized

| Register   | When the power is turned ON | *RST Command | *CLS Command |
|--|-----------------------------|--------------|--------------|
| Device-specific functions (measurement conditions, compensation value, etc.) | –                           | ✓            | –            |
| Output queue   | ✓                           | –            | –            |
| Input buffer   | ✓                           | –            | –            |
| Status byte register   | ✓                           | –            | ✓ *1         |
| Event register   | ✓ *2                        | –            | ✓            |
| Enable register  | ✓                           | –            | –            |
| Current path   | ✓                           | –            | –            |

\*1. Other than the MAV bit are cleared.

\*2. The PON bit (bit 7) is excluded.

## 1.1 Product Overview and Features

The instrument is a multichannel data logger that combines individual measuring modules. It is used for recording physical readings, including temperatures and voltages.

### Both LR8101 and LR8102

- **Choice of modules according to applications**

| Features  | Modules                   |
|---|---------------------------|
| Maximum rated line-to-ground voltage is 1500 V. Voltage recording at intervals of 5 ms. | M7100 Voltage/Temp Module |
| Temperature recording in 30 channels  | M7102 Voltage/Temp Module |

- **Up to 10 modules can be connected depending on the number of channels**

When 10 M7102 units are connected, up to 300 channels can be recorded.

### LR8102 only

- **Data output based on UDP**

Measurement data are output for every sampling in real time. The fastest speed is achieved with intervals of 5 ms.

This is useful when realtime processing is required, such as HILS.

- **Multiple instruments synchronized for measurement**

Synchronized measurement is enabled with an optional L6101 Optical Connection Cable (1 m) or L6102 Optical Connection Cable (10 m).

The measurement data from all of the synchronized instruments can be output from LAN2 of the primary instrument.

- **Data output via CAN**

The measured value can be output via a Controller Area Network (CAN).

The value can be used for data integration with the information of an in-vehicle device, such as the battery management system (BMS).

# 1.2 Part Names and Functions

## LR8101 and LR8102 Data Loggers

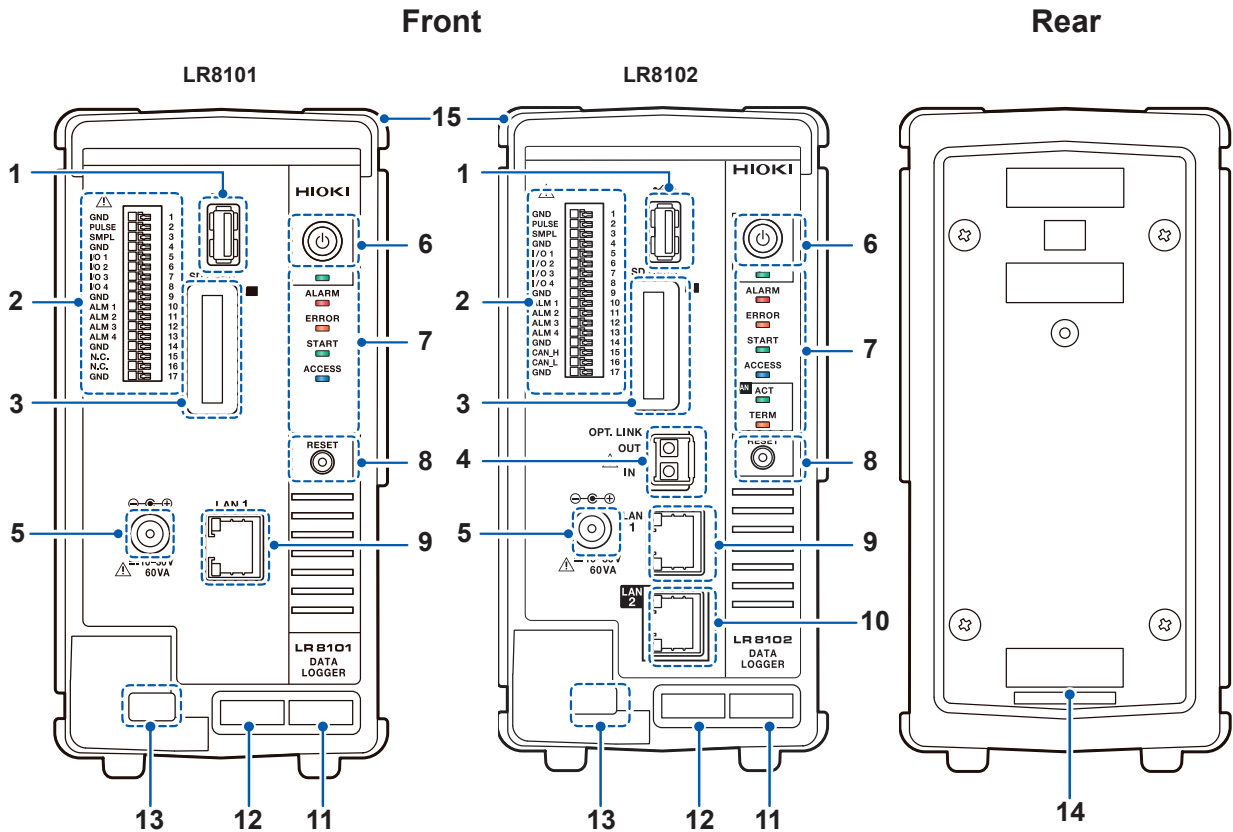







| No. | Name                                | Function   | Reference |
|-----|-------------------------------------|--|-----------|
| 1   | USB connector                       | Optional USB drive can be connected.   | p.59      |
| 2   | External control terminal           | Allows you to control the instrument with external signals. Alarm signal can be output.                | p.49      |
| 3   | SD card slot                        | Optional SD memory card can be inserted.   | p.58      |
| 4   | Optical synchronization connector*1 | Optional optical connection cable can be connected.  | p.53      |
| 5   | Power supply terminal               | Optional Z1016 AC Adapter can be connected. External power supply can be connected (10 V to 30 V DC).  | p.40      |
| 6   | POWER key                           | Allows you to turn ON and OFF the power.   | p.55      |
| 7   | LED                                 | See the next page  | p.31      |
| 8   | RESET key                           | Allows you to initialize the settings. Allows you to cancel the warning status.                        | p.32      |
| 9   | LAN1 port                           | LAN cable can be connected. (100BASE-TX/1000BASE-T)  | p.60      |
| 10  | LAN2 port*1                         | LAN cable can be connected. (100BASE-TX/1000BASE-T)  |           |
| 11  | MAC address (LAN1)                  | Indicates the MAC address assigned to LAN1. Do not remove it as the number is required for management. | -         |

\*1. LR8102 only

| No. | Name                             | Function   | Reference |
|-----|----------------------------------|--|-----------|
| 12  | Serial number                    | Consists of 9 digits. Starting from the left, the first pair of digits indicate the year of manufacture (last two digits of the year), and the next pair of digits indicate the month of manufacture.<br>Do not remove it as the number is required for management. Share this number when contacting your reseller. | -         |
| 13  | Cable hook                       | To prevent the AC adapter from coming off, pass the AC adapter cable through this hook.  | p.38      |
| 14  | MAC address (LAN2)* <sup>1</sup> | Indicates the MAC address assigned to LAN2. Do not remove it as the number is required for management.   | -         |
| 15  | Connecting cover                 | When using the instrument without connecting a module, install the cover.  | p.38      |

\*1. LR8102 only

## LED

| LED   | Name                       | Function  | Reference |
|---|----------------------------|---|-----------|
|    | <b>POWER</b>               | Lights up when the power is ON.                               | p.55      |
|    | <b>ALARM</b>               | Lights up when an alarm is issued.                            | p.185     |
|   | <b>ERROR</b>               | Blinks when an error occurs. Lights up when a warning occurs. | p.350     |
|  | <b>START</b>               | Lights up while measurement is performed.                     | p.118     |
|  | <b>ACCESS</b>              | Lights up when the SD memory card or USB drive is accessed.   | p.56      |
|  | <b>ACT</b> * <sup>1</sup>  | Blinks when the CAN output is activated.                      | p.51      |
|  | <b>TERM</b> * <sup>1</sup> | Lights up when the CAN terminator is ON.                      |           |

\*1. LR8102 only

- The LEDs light up in sequence until the startup is completed.  
ALARM → ERROR → START → ACCESS
- When the instrument is updated, the LEDs blink in sequence according to the progress.  
ALARM → ERROR → START → ACCESS
- When the ROM and RAM of the instrument are checked, the LEDs blink in sequence according to the progress.  
ALARM → ERROR → START → ACCESS

**Key operation on the instrument**

| Key              | Function                    | Operation  | Reference |
|------------------|-----------------------------|--|-----------|
| <b>POWER key</b> | Shutdown                    | When the key is pressed once, the LED starts blinking (approx. 5 seconds). Pressing the key again while the LED is blinking turns OFF the power. | -         |
| <b>RESET key</b> | Initialization (full reset) | Holding down the key during startup fully resets the instrument. Keep holding down the key until the LED blinks and a buzzer sounds.             | p.234     |
|                  | Warning status clear        | Pressing the key once in the warning status (ERROR LED is lit) cancels the warning status.   | p.353     |
|                  | Alarm hold clear            | Pressing the key once during alarm hold cancels the hold status.   | p.185     |

**Side**

LR8101, LR8102

Right side

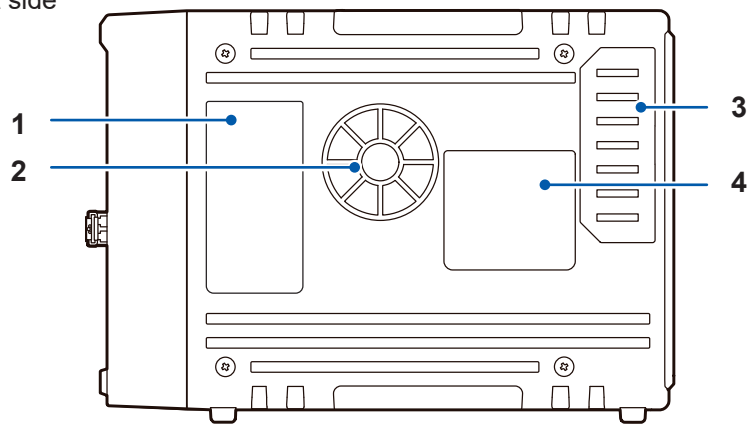

Left side

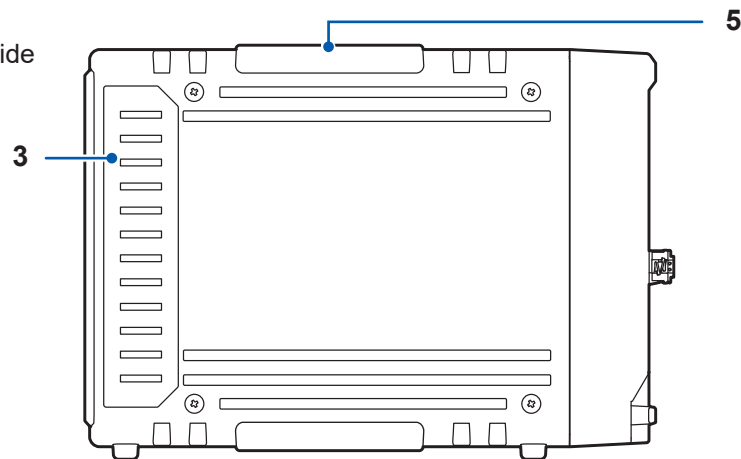

| No.      | Name                          | Function   | Reference |
|----------|-------------------------------|--|-----------|
| <b>1</b> | <b>Description of the LED</b> | Indicates the operation of the LED located at the front of the instrument.   | p.31      |
| <b>2</b> | <b>Air vent</b>               | Ventilates the instrument to prevent the temperature of the inside from going up excessively.  | p.13      |
| <b>3</b> | <b>Connector cover</b>        | Under the cover, there is a connector to connect a module. When using the instrument without connecting a module, install the connector cover. | p.38      |
| <b>4</b> | <b>Warning</b>                | Provides the important information of the instrument.  | -         |



## 1.3 Options

### Measurement modules

1

Overview

|       | Product name        | Measurement target                  | Number of channels | Shortest sampling interval |
|-------|---------------------|-------------------------------------|--------------------|----------------------------|
| M7100 | Voltage/Temp Module | Voltage, temperature (thermocouple) | 15                 | 5 ms <sup>*1</sup>         |
| M7102 | Voltage/Temp Module | Voltage, temperature (thermocouple) | 30                 | 10 ms <sup>*2</sup>        |

\*1. Only when the number of channels used in a module is eight or less and the voltage range is used.

\*2. The number of channels used in a module is 15 or less.

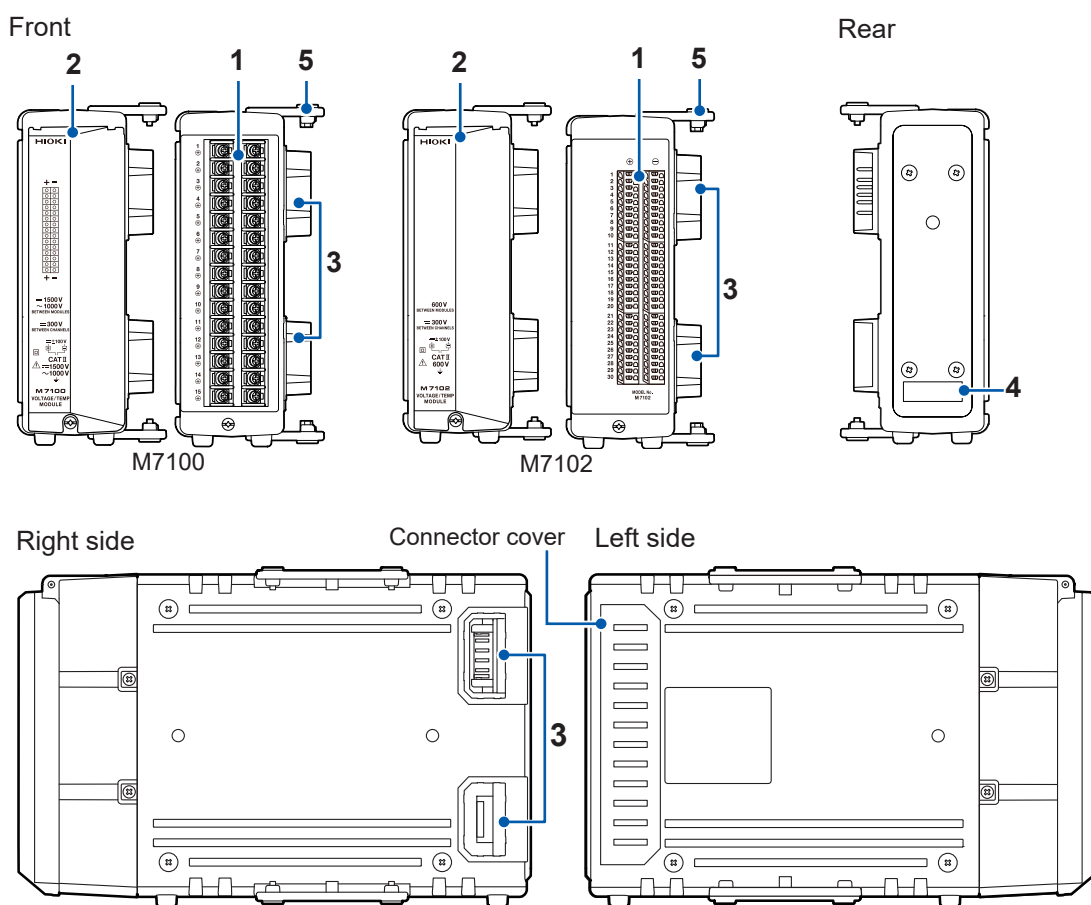

| No. | Name                 | Function  |
|-----|----------------------|---|
| 1   | Input terminal       | The input terminal for each channel. The number represents the channel number.  |
| 2   | Terminal block cover | The cover protects the terminal block. Close the cover during the measurement.  |
| 3   | Connector            | The connector for measurement module extension. Install the connector cover on the connector when it is not used.   |
| 4   | Serial number        | Consists of 9 digits. Starting from the left, the first pair of digits indicate the year of manufacture (last two digits of the year), and the next pair of digits indicate the month of manufacture. Do not remove it as the number is required for management. Share this number when contacting your reseller. |
| 5   | Connecting plate     | The plate for connecting the measurement modules. After connecting the modules, fix the plate using screws.   |

## Other options

---

### Z1016 AC Adapter

Allows you to drive the instrument using a commercial power supply (AC driven).

- Rated supply voltage (100 V to 240 V AC)
- Rated power-supply frequency (50 Hz/60 Hz)



---

### L1012 Power Cable

Allows you to drive the instrument using DC power supply.



---

### Z4001 SD Memory Card (2 GB)

### Z4003 SD Memory Card (8 GB)

### Z4006 USB Drive (16 GB)

The measurement data and the setting conditions can be stored in SD memory cards and USB drives. The operation cannot be guaranteed if an SD memory card or USB drive other than the optional one is used.



---

### L6101 Optical Connection Cable (1 m)

### L6102 Optical Connection Cable (10 m)

The optical connection cable is required for synchronizing multiple units of LR8102.

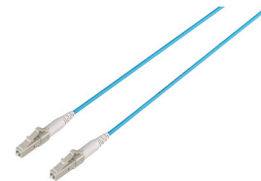

---

### 9713-01 CAN Cable

Option for LR8102.

The CAN Cable is used for CAN output.

Length: 2.0 m



## 1.4 Measurement Workflow

The measurement procedure with the instrument is as follows.

For steps 4 to 6, the method for sending commands from a PC is explained in this manual.

For details about the command operations as well as other operations not related to the commands, see “12 Communication with PC (Computer)” (p.249).

1

Overview

### 1. Preparation of the instrument

See “2 Connection (Preparation for Measurements)” (p.37).

- Install the measurement modules on the instrument.
- Connect the AC adapter.

### 2. Preparation of the instrument

See “2.5 Connecting Cables” (p. 42).

- Connect the LAN cable on the instrument.
- Connect the cables for the thermocouples, etc. to the terminal block of the measurement modules.

### 3. Turn ON the power

See “2.6 Turning ON and OFF the Power” (p. 55).

- Pressing the POWER key turns ON the instrument.

### 4. Set and connect the LAN

See “2.8 Setting and Connecting the LAN” (p. 60)

### 5. Set the instrument

See “3.3 Setting Measurement Conditions” (p. 82).

- Before starting the measurement, set the measurement conditions using communication commands.  
See “3.1 Controlling the Instrument Using Communication Commands” (p. 77).
- Set the recording interval (sampling interval) and the recording time.

See “3.4 Setting the Voltage/Temp Module” (p. 94).

- Set the input types and ranges for the voltage, thermocouple, etc.

### 6. Start and stop the measurement

See “3.9 Starting and Stopping Measurement” (p. 118).

- Send the **START** command to start the measurement.
- Send the **STOP** command to stop the measurement.

## 7. Acquire the waveform data



See “4 Acquiring Measurement Data” (p.123).

See “4.2 Acquiring Realtime Data” (p. 127).



Select an appropriate data acquisition method according to the application.

See “4.7 Comparison of Realtime Data Acquisition” (p. 136).

# Connection (Preparation for Measurements)

This chapter explains preparation prior to starting a measurement. For the power supply, use the AC adapter or an external power supply. Install and wire the modules and cables according to the measurement target. An SD memory card or USB drive can be selected as a storage medium.

## 2.1 Inspection Before Use

### DANGER

- Before using the instrument, check the measurement cables to confirm that the insulation is not worn and no metal parts are exposed.



- Inspect the instrument and verify proper operation before use.

Using a damaged cable or instrument could result in serious bodily injury. Replace with those specified by our company if you find any damage.

Inspect the instrument before turning ON the power, and ensure that no damage occurred during storage or shipping.

If you find any damage, contact your authorized Hioki distributor or reseller.

### Inspecting the peripheral devices

Inspect the measurement cables to confirm that the insulation is not worn and no metal parts are exposed.

Do not use a measurement cable if you find any damage. Failure to do so could cause the operator to experience an electric shock. Replace with those specified by our company.

### Inspecting the instrument

- Confirm that the instrument is not damaged.  
If you find any damage, request repair.
- Turn ON the instrument and confirm that the POWER LED lights up.  
If the LED does not light up, the power cord may be broken or the instrument may be damaged.  
Request repair.

## 2.2 Connecting the Measurement Modules

Up to 10 optional measurement modules can be connected to one instrument. Determine the number of measurement modules to be connected according to the number of channels required for the measurement.

### ⚠ WARNING



- **When no measurement module is connected, do not remove the connector cover.**

Doing so could cause the operator to experience an electric shock or damage the instrument and measurement modules.



- **Before connecting or disconnecting the measurement modules, turn OFF the instrument and remove the cables.**

Failure to do so could cause the operator to experience an electric shock or damage the instrument and measurement modules.

### Connecting the Measurement Modules to the Instrument

Applicable modules: M7100, M7102

Required items: Phillips screwdriver (No. 2)

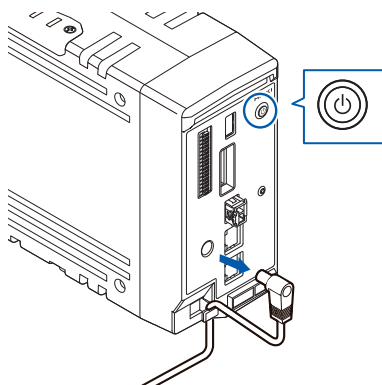

- 1 Turn OFF the instrument and remove the AC adapter.**

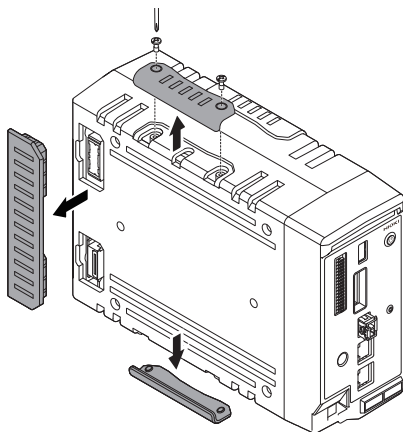

- 2 Remove the connector covers.**

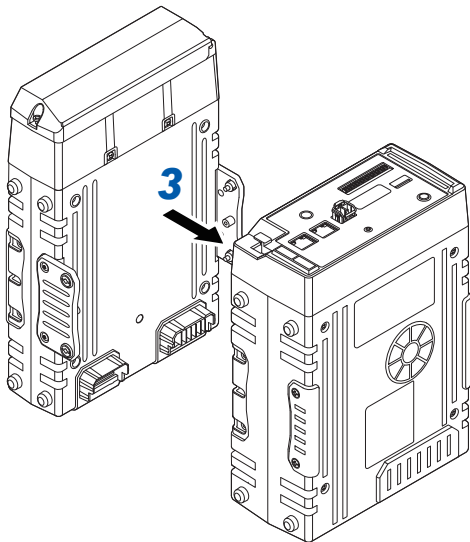

- 3** Connect a measurement module to the connector of the instrument.

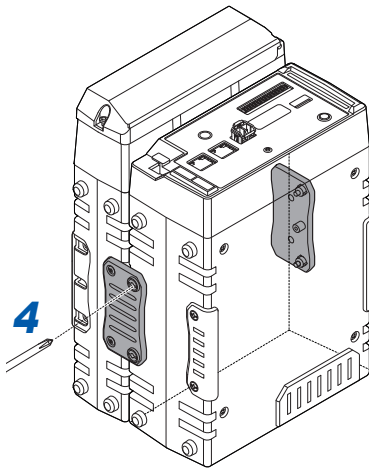

- 4** Tighten the fall prevention screws (4 locations). Tighten the screws at 0.6 N•m.

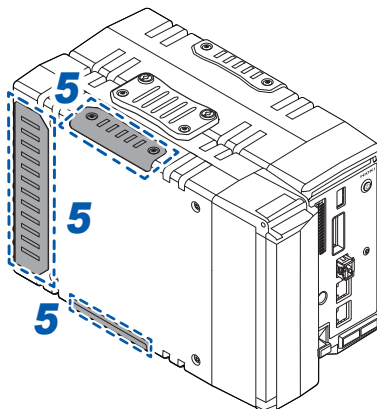

- 5** Reattach the connector covers removed in 2. Tighten the screws at 0.6 N•m.

### Connecting an additional measurement module

An additional measurement module can be installed on the left side of the first measurement module.

Connect the additional measurement module in the same way as you connected the first measurement module to the instrument.

## 2.3 Connecting the AC adapter

Connect the power cord to the AC adapter, and then connect the AC adapter to an outlet.

Make sure to use the optional Z1016 AC Adapter (2-pole grounding power cord included). Before connecting, make sure to read "Handling of cords and cables" (p. 42).

In addition, turn OFF the instrument before connecting or disconnecting the AC adapter.

### ⚠ WARNING

- **When supplying the power from a commercial power supply to the instrument, use the optional Z1016 AC Adapter (2-pole grounding power cord included).**

- **Use the AC adapter at the rated supply voltage and the rated supply frequency.**



Rated supply voltage: 100 V AC to 240 V AC (voltage fluctuation within  $\pm 10\%$ )  
Rated supply frequency: 50/60 Hz

- **Turn OFF the instrument before connecting the AC adapter to the instrument and the commercial power supply.**

Failure to do so could cause the operator to experience an electric shock.

- **Connect the power cord of the AC adapter to a 2-pole grounding outlet.**

Connecting the power cord to an ungroundable outlet could cause the operator to experience an electric shock.

### ⚠ CAUTION

- **Before connecting the plug to the outlet, connect the output plug of the AC adapter to the instrument.**



Failure to do so could damage the instrument.

- **When unplugging the power cord from the outlet or instrument, pull on the plug (not the cord).**

The cable may be broken or the output terminal may be damaged.

### Supply the power to the instrument using the AC adapter (AC driven)

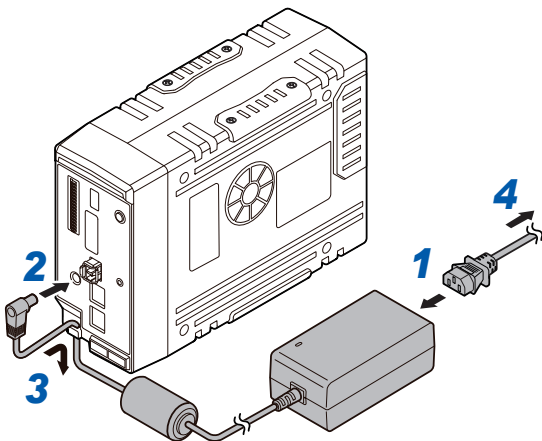

- 1** Connect the power cord to the Z1016 AC Adapter.
- 2** Connect the output plug of the AC adapter to the power supply terminal of the instrument.
- 3** To prevent the plug from coming off, press the output cord of the AC adapter cable into the cable hook of the instrument.
- 4** Connect the plug of the power cord to the outlet.



## 2.4 Connecting an External Power Supply

A DC power supply can be used as an external power supply for the instrument. Be sure to use the optional L1012 Power Cable. Before connecting, make sure to read “Handling of cords and cables” (p. 42). In addition, turn OFF the instrument before connecting or disconnecting the power cable.

### ⚠ CAUTION

- Use the external power supply at the rated supply voltage.

Rated supply voltage: 10 V DC to 30 V DC



- Turn OFF the instrument before connecting the power cord.
- Pay attention to the polarity and correctly connect the terminals of the power cord.

Failure to do so could damage the instrument.

### Supply the power to the instrument from an external power supply (DC driven)

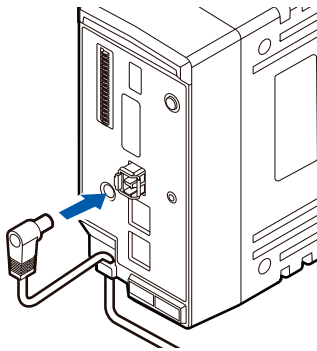

- 1 Connect the plug of the power cord to the power supply terminal of the instrument.
- 2 To prevent the plug from coming off, press the power cord into the cable hook of the instrument.
- 3 Pay attention to the polarity and connect the terminals of the power cord to the DC power supply.

#### IMPORTANT

When a power cord that is 3 m or longer is connected, the instrument may be affected by factors in the EMC environment, such as exogenous noise.

## 2.5 Connecting Cables

### Handling of cords and cables

#### WARNING

- **Hang the measurement cables lower than the instrument.**

Otherwise, water or liquid could enter the instrument along the measurement cables, damaging the instrument and causing bodily injury.

- **Follow the procedure below before wiring the measurement terminals or turning ON the instrument.**

1. Shut down the power of the measurement line.
2. Turn OFF the instrument and other devices.
3. Remove the measurement target.
4. Close the terminal block cover.



- **Use the specified wiring materials. Alternatively, use wiring materials with sufficient dielectric strength and current capacity.**

Otherwise, accidents due to electric shock or short circuit may occur.

- **Securely connect the measurement cables to the input terminals.**

Loose terminals could result in increased contact resistance, causing the product to become hot or burn up or resulting in bodily injury or fire.

#### CAUTION

- **Do not route cords between other objects or step on them.**

Doing so could damage the insulation and cause the operator to experience an electric shock.



- **Do not input voltage that exceeds the specified rating between the channels.**

Semiconductor relays are used for the insulation between the channels of the measurement module. When any voltage that exceeds the specified rating is applied, such as lightning surges, the semiconductor relays can fail with a short-circuit.

#### IMPORTANT

- When a cable that is 3 m or longer is connected, measurement may be affected by factors in the EMC environment, such as exogenous noise. Position the cable away from the power line or ground cable.
- When the cable is connected in parallel to other equipment, measurement values may vary. If the measurement cable is to be connected in parallel, make sure to check the operation before use.

## When connecting to the input terminal

### DANGER



- **Do not leave the input cables connected in an environment where there is a possibility of surges exceeding the dielectric strength.**

Doing so may damage the instrument, resulting in serious bodily injury.

### WARNING

- **Follow the procedure below before wiring the input terminal.**



1. Turn off the power of this instrument and the instrument to be connected.
2. Discharge static electricity from your body.

Failure to do so could cause the operator to experience an electric shock or damage the instrument.

When wiring with a crimped terminal, use an insulation coated terminal with the following size for M3 screws.



6 mm or less



6 mm or less

## When wiring the external control terminal

### WARNING

- **Follow the procedure below before wiring the external control terminal.**



1. Turn off the power of this instrument and the instrument to be connected.
2. Discharge static electricity from your body.
3. Check that the signal does not exceed the external input and output rating.
4. Properly isolate this instrument and the instrument to be connected to the EXT. I/O connector terminal.

Failure to do so could cause the operator to experience an electric shock or damage the instrument.

### CAUTION



- **Do not short or input any voltage to the output unit.**

The instrument can be damaged.



- **Ensure that there is no potential difference between the ground of the external control terminal and the ground of the connection target.**

Failure to do so could damage the connection target and the instrument. The ground of the external control terminal and the ground of the instrument are common and they are not isolated from each other.

When using a twisted pair wire for the measurement cable, take care not to allow the measurement cable to contact adjacent measurement cables or terminals.

## Wiring the voltage cable and thermocouple

### Connection to a screw type terminal block

#### ⚠ WARNING



- Use the dedicated screws to fix the wiring to a screw type terminal block.

Using screws other than the dedicated ones could cause the operator to experience an electric shock or damage the instrument.

Applicable module: M7100

Required items: Phillips screwdriver (No. 2), input cable or thermocouple

Recommended wire diameter

|                               |   |
|-------------------------------|---|
| Solid                         | ø0.2 mm to ø1.29 mm (AWG32-16)                          |
| Stranded                      | 0.03 mm <sup>2</sup> to 1.38 mm <sup>2</sup> (AWG32-16) |
| Standard stripped wire length | 10 mm   |

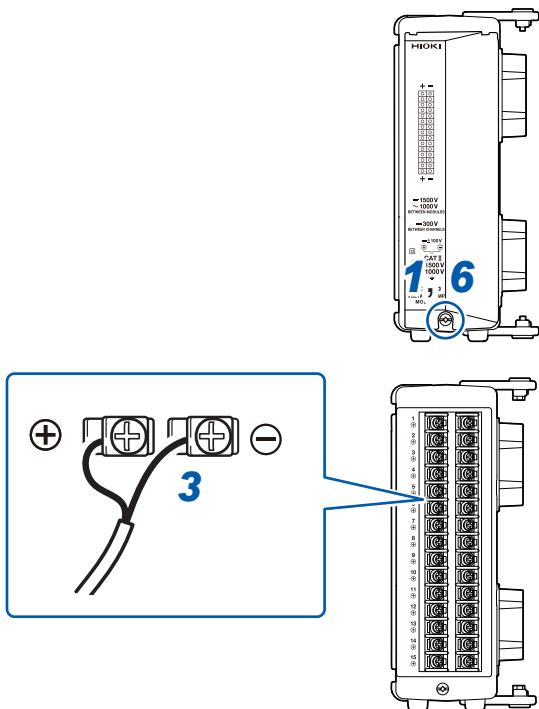

**1** Remove the screw for the terminal block cover.

**2** Open the terminal block cover.

**3** Loosen the terminal block screws. Insert the wires of the cable as shown in the figure and tighten the screws.

Tighten the terminal block screws at 0.5 N·m. The color scheme for the cable sheath varies with different countries and manufacturers. Confirm the colors before connecting the cable.

**4** Connect the cable to the measurement target.

**5** Close the terminal block cover.

**6** Tighten the screw for the terminal block cover.

When measuring an instrumentation device (inputting a current of 4-20 mA), connect a 250  $\Omega$  shunt resistor as shown in the figure below. For the measurement of instrumentation devices, see “When measuring the output from an instrumentation device” (p. 95).

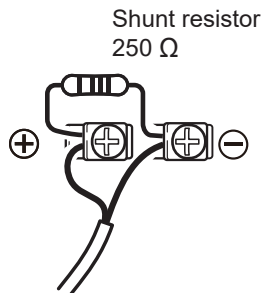
**IMPORTANT**

Be sure to fix the **terminal block** cover using the screw.  
If the **terminal block** cover is not closed, the measured values may be affected.

## Connecting to a push-button type terminal block

Applicable module: M7102

Required items: Flat-head screwdriver (blade edge width 2.6 mm), input cable or thermocouple

Recommended wire diameter

|                               |  |
|-------------------------------|--|
| Solid                         | ø0.32 mm to ø1.29 mm (AWG26-16)                        |
| Stranded                      | 0.2 mm <sup>2</sup> to 0.52 mm <sup>2</sup> (AWG24-20) |
| Standard stripped wire length | 9 mm   |

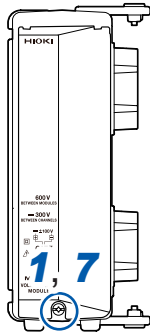

**1** Remove the screw for the terminal block cover.

**2** Open the terminal block cover.

**3** Press the terminal button with a flat-head screwdriver and insert the wire of the cable into the terminal hole.

The color scheme for the cable sheath varies with different countries and manufacturers. Confirm the colors before connecting the cable.

**4** Remove the flat-head screwdriver from the button.

The cable is locked. Pull the cable gently and confirm that the cable will not come out.

**5** Connect the cable to the measurement target.

**6** Close the terminal block cover.

**7** Tighten the screw for the terminal block cover.

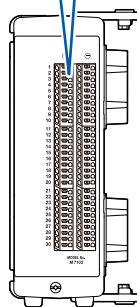
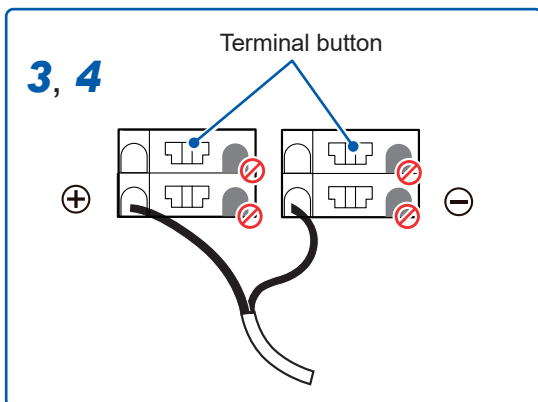

### IMPORTANT

Be sure to fix the terminal block cover using the screw.

If the terminal block cover is not closed, the measured values may be affected.

## Wiring for the pulse input

Connect a cable to the external control terminal.

Required items: Flat-head screwdriver (blade edge width 2.6 mm), input cable (pulse measurement)

Recommended wire diameter

|                               |   |
|-------------------------------|---|
| Solid                         | ø0.32 mm to ø0.81 mm (AWG28-20)                         |
| Stranded                      | 0.08 mm <sup>2</sup> to 0.32 mm <sup>2</sup> (AWG28-20) |
| Standard stripped wire length | 10 mm   |

- 1** Turn forward the external control terminal on the front of the instrument.
- 2** Press the button of the PULSE terminal with a flat-head screwdriver.
- 3** While holding down the button, insert the plus (+) cable into the terminal hole.
- 4** Remove the flat-head screwdriver from the button.  
The cable is locked. Pull the cable gently and confirm that the cable will not come out.
- 5** Press the button of the GND terminal with a flat-head screwdriver.  
Five ground terminals are available. The cable can be connected to any of the ground terminals.
- 6** While holding down the button, insert the minus (-) cable into the terminal hole.
- 7** Remove the flat-head screwdriver from the button.  
The cable is locked. Pull the cable gently and confirm that the cable will not come out.

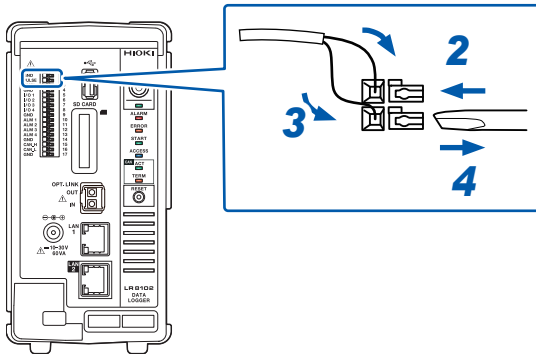

## Wiring for the alarm output

Connect a cable to the external control terminal.

Required items: Flat-head screwdriver (blade edge width 2.6 mm), output cable (alarm output)

Recommended wire diameter

|                               |   |
|-------------------------------|---|
| Solid                         | ø0.32 mm to ø0.81 mm (AWG28-20)                         |
| Stranded                      | 0.08 mm <sup>2</sup> to 0.32 mm <sup>2</sup> (AWG28-20) |
| Standard stripped wire length | 10 mm   |

- 1** Turn forward the external control terminal on the front of the instrument.
- 2** Press the button of the ALM 1 (or ALM 2 to ALM 4) terminal with a flat-head screwdriver.
- 3** While holding down the button, insert the cable into the terminal hole.
- 4** Remove the flat-head screwdriver from the button.

The cable is locked. Pull the cable gently and confirm that the cable will not come out.

- 5** Press the button of the GND terminal with a flat-head screwdriver.
- Five ground terminals are available. The cable can be connected to any of the ground terminals.

- 6** While holding down the button, insert the cable into the terminal hole.

- 7** Remove the flat-head screwdriver from the button.

The cable is locked. Pull the cable gently and confirm that the cable will not come out.

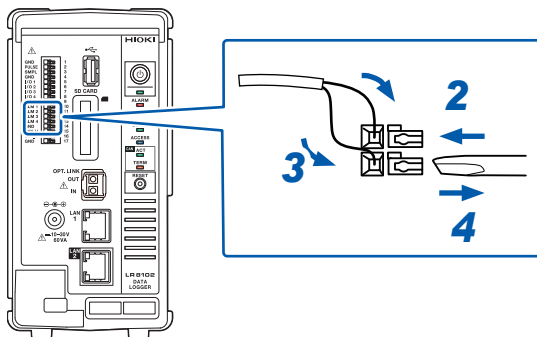



## Wiring for external control

Connect a cable to the external control terminal.

- External input: Allows you to control the start and stop of the measurement and input the trigger signals.

See “5.5 Applying External Trigger” (p. 153) and

“11.2 Setting the External Input and Output (I/O) Terminals” (p. 243).

- External output: Signals can be output when the trigger is activated.

See “11.2 Setting the External Input and Output (I/O) Terminals” (p. 243).

Required items: Flat-head screwdriver (blade edge width 2.6 mm), input cable (pulse measurement)

Recommended wire diameter

|                               |   |
|-------------------------------|---|
| Solid                         | ø0.32 mm to ø0.81 mm (AWG28-20)                         |
| Stranded                      | 0.08 mm <sup>2</sup> to 0.32 mm <sup>2</sup> (AWG28-20) |
| Standard stripped wire length | 10 mm   |

- 1** Turn forward the external control terminal on the front of the instrument.
- 2** Press the button of the I/O 1 (or I/O 2 to I/O 4) terminal with a flat-head screwdriver.
- 3** While holding down the button, insert the cable into the terminal hole.
- 4** Remove the flat-head screwdriver from the button.  
The cable is locked. Pull the cable gently and confirm that the cable will not come out.
- 5** Press the button of the GND terminal with a flat-head screwdriver.  
Five ground terminals are available. The cable can be connected to any of the ground terminals.
- 6** While holding down the button, insert the cable into the terminal hole.
- 7** Remove the flat-head screwdriver from the button.  
The cable is locked. Pull the cable gently and confirm that the cable will not come out.

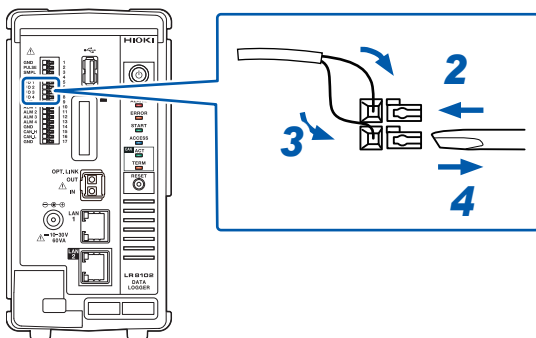

## Wiring for the external sampling

Connect a cable to the external control terminal.

Required items: Flat-head screwdriver (blade edge width 2.6 mm), input cable (pulse measurement)

Recommended wire diameter

|                               |   |
|-------------------------------|---|
| Solid                         | ø0.32 mm to ø0.81 mm (AWG28-20)                         |
| Stranded                      | 0.08 mm <sup>2</sup> to 0.32 mm <sup>2</sup> (AWG28-20) |
| Standard stripped wire length | 10 mm   |

**1** Turn forward the external control terminal on the front of the instrument.

**2** Press the button of the SMPL terminal with a flat-head screwdriver.

**3** While holding down the button, insert the plus (+) cable into the terminal hole.

**4** Remove the flat-head screwdriver from the button.

The cable is locked. Pull the cable gently and confirm that the cable will not come out.

**5** Press the button of the GND terminal with a flat-head screwdriver.

Five ground terminals are available. The cable can be connected to any of the ground terminals.

**6** While holding down the button, insert the minus (-) cable into the terminal hole.

**7** Remove the flat-head screwdriver from the button.

The cable is locked. Pull the cable gently and confirm that the cable will not come out.

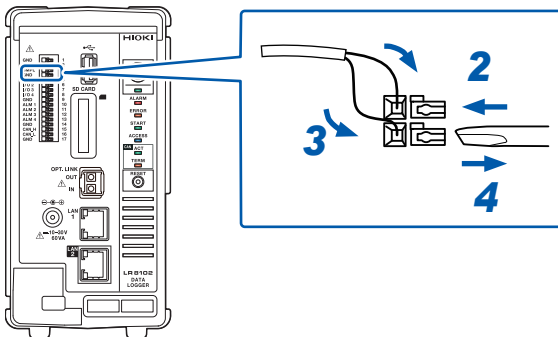

## Wiring the CAN cable (LR8102 only)

Required items: Flat-head screwdriver (blade edge width 2.6 mm), 9713-01 CAN cable

### ! WARNING



- Turn OFF all devices before connecting or disconnecting interface connectors.

Failure to do so could cause the operator to experience an electric shock.

### ! CAUTION



- Do not unplug the input cable while the instrument is sending or receiving data.

Doing so could cause an unexpected error on the CAN bus.

- 1 Turn forward the external control terminal on the front of the instrument.
- 2 Press the terminal button with a flat-head screwdriver and insert the wire of the cable into the terminal hole.

| Terminal | Cable           |
|----------|-----------------|
| CAN_H    | CAN_H (red)     |
| CAN_L    | CAN_L (green)   |
| GND      | CAN_GND (black) |

Five ground terminals are available. The cable can be connected to any of the ground terminals.

- 3 Remove the flat-head screwdriver from the button.  
The cable is locked.
- 4 Pull the cable gently and confirm that the cable will not come out.

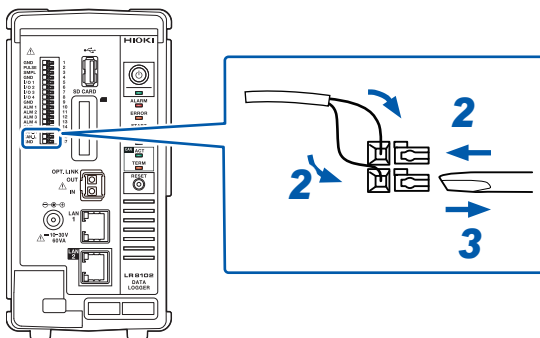

## Terminator setting

- The CAN communication system requires 120 Ω terminators on both sides of the bus.

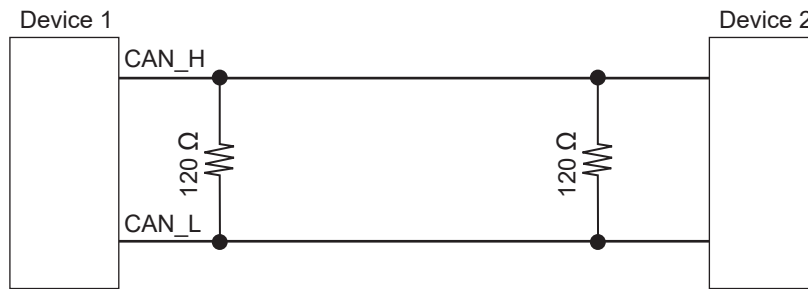

- If the terminator is set to ON, the 120 Ω resistors are inserted between the differential signals of the CAN bus inside the LR8102.  
See “14.11 Configuration of Input Circuit” (p. 335).

## Description of the LED operations

The operation status of the CAN can be checked with the LEDs.

| LED             | Status  |
|-----------------|---|
| <b>ACT LED</b>  | <ul style="list-style-type: none"> <li>Blinking: When the output signal is received properly*<sup>1</sup></li> <li>Lamp OFF: When there is no output target*<sup>2</sup></li> </ul> |
| <b>TERM LED</b> | <ul style="list-style-type: none"> <li>Lit: When the terminator is ON</li> <li>Lamp OFF: When the terminator is OFF</li> </ul>  |

\*1. The LED blinks if any one of the set CAN communications is performed in accordance with the conditions.  
See CAN Editor Instruction Manual “6.3 Receive CAN Data”.

\*2. The conditions for the CAN communication may not be satisfied or the CAN port may not be connected with the CAN bus correctly.

See CAN Editor Instruction Manual “5.4 Setting the Communication Method of the CAN Unit”.

Check that there is a channel for which the output is ON.

See CAN Editor Instruction Manual “7.5 Selecting the Channel to be Output”.

## Wiring the optical connection cable (LR8102 only)

### CAUTION

- **Do not connect or disconnect connectors while the instrument is powered ON.**

Doing so could damage the instrument.



- **Do not bend or pull the optical connection cables.**

Bending or pulling the cables may result in cable breakage or damaged insulation, causing the instrument to malfunction.

Using the optional L6101 or L6102 Optical Connection Cable to connect instruments in a daisy chain enables synchronized measurement with up to 10 units.

Since the units are synchronized using optic fiber without electrical signals, instruments with different ground potential can be connected without any problems.

#### IMPORTANT

- Up to 10 units can be synchronized. Eleven or more units cannot be synchronized.
- The cable can only be connected with the instrument. Connecting the cable with other devices may cause a malfunction.

Required items: Instruments (2 to 10 units), L6101 or L6102 Optical Connection Cable (the same number of cables as the instruments)

- 1 Make sure that the instruments are turned OFF.**
- 2 Connect the OUT terminal of the optical synchronization connector of the primary unit and the IN terminal of the optical synchronization connector of the secondary unit using an optical connection cable.**
- 3 For multiple secondary units**  
**Connect the OUT terminal of the optical synchronization connector of the secondary unit and the IN terminal of the optical synchronization connector of another secondary unit using an optical connection cable.**

Repeat this step until all the IN terminals of the optical synchronization connectors of the secondary units are connected.

- 4** There is a secondary unit for which the OUT terminal of the optical synchronization connector remains unconnected with an optical connection cable. Connect the unconnected OUT terminal and the IN terminal of the optical synchronization connector of the primary unit.

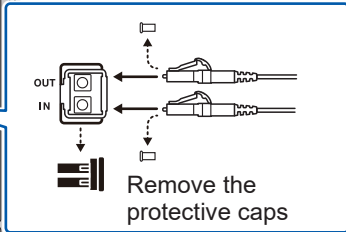
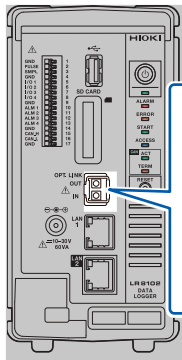

When two units are connected

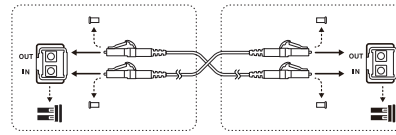

When three units are connected



**IMPORTANT**

- Never unplug the cable during the synchronization control. The synchronization may fail.
- A synchronization error occurs if either of the power supplies for the primary and secondary units is turned OFF.
- Use primary and secondary units with the same version. Using different versions results in a synchronization error.

## 2.6 Turning ON and OFF the Power

### ⚠ WARNING



- Before turning ON the power, make sure that the supply voltage you plan to use falls within the supply voltage range indicated on the instrument's AC adapter.

Supplying a voltage that falls outside the specified range to the AC adapter could damage the instrument or the AC adapter, causing bodily injury.

### ⚠ CAUTION



- Do not input voltage to the input terminal while the instrument is powered OFF.

Doing so could damage the instrument.

### IMPORTANT

- Be sure to turn OFF the power after using the instrument.
- An instantaneous power failure longer than 40 ms could shut down the power supply, causing the instrument to malfunction. Check the status of the power supply.

### Procedure to turn on the instrument

Pressing the POWER key turns ON the instrument. The POWER LED lights up in green.

### Procedure to turn off the instrument

When the POWER key is pressed, the LEDs blink for 5 seconds.

Pressing the POWER key again while the LEDs are blinking turns OFF the power.

The POWER LED is turned OFF.

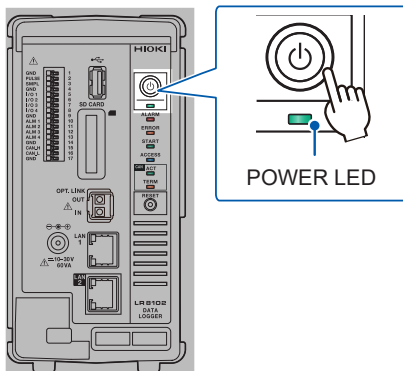

## 2.7 SD Memory Card and USB Drive

The measurement data and the setting conditions of the instrument can be stored in SD memory cards and USB drives.

In addition, the stored data can be loaded and reproduced on the instrument.

For the data storage, use the following options.

Z4001 SD Memory Card (2 GB), Z4003 SD Memory Card (8 GB),

Z4006 USB Drive (16 GB)

### WARNING



- **Do not modify, disassemble, or repair an SD memory card and USB drive.**

Doing so could result in serious bodily injury or fire.



- **Keep these parts out of reach of children.**

Children may accidentally swallow an SD memory card or USB drive.

### CAUTION

- **Do not attach a label and the like to an SD memory card.**

Doing so could cause the SD memory card to overheat, exposing the operator to a risk of being burned or causing fire.

- **Do not allow water to drip on the terminal of an SD memory card or USB drive.**
- **Do not touch the terminal or contact surface of an SD memory card. Do not allow a metal object to contact these areas.**

- **Do not bend or drop an SD memory card. Do not subject an SD memory card to mechanical shock.**



- **While the instrument is accessing an SD memory card or USB drive, do not subject the instrument to vibration or mechanical shock. Do not turn OFF the instrument. Do not remove an SD memory card or USB drive from the instrument.**

- **Before formatting an SD memory card, make sure that no necessary information, such as files, is stored on the card.**

The internal data could be damaged or lost.

- **Do not forcefully insert an SD memory card or USB drive with the wrong side up or in the wrong direction.**

The SD memory card, the USB drive, or the instrument can be damaged.

- **Do not transport the instrument while it is connected to a USB drive.**

The USB drive or the instrument can be damaged.



## CAUTION

- **Take measures to prevent static electricity from being applied to an SD memory card or USB drive.**

Failure to do so could damage the SD memory card or USB drive and cause the instrument to malfunction.

- **Use a USB drive within the specified ranges of temperature and humidity.**

The USB drive can be damaged.

- **Back up important data and store it in a safe place.**

SD memory cards and USB drives have a service life because flash memory is used. They lose the ability to store and load data after extended or frequent use. If you encounter this issue, purchase a new drive. Hioki is not liable for data stored on SD memory cards or USB drives, regardless of the nature or cause of the accident or damage involved.



- **When formatting an SD memory card or USB drive with a PC, select the FAT/FAT32.**

The media formatted to other formats (NTFS, etc.) cannot be recognized with the instrument.

- **Discharge static electricity from your body before handling an SD memory card or USB drive.**

- **Turn ON the instrument before inserting an SD memory card or USB drive.**

Failure to do so could damage the SD memory card or USB drive, or cause the instrument to malfunction. The instrument may fail to start up if it is turned on while a USB drive is inserted.

### IMPORTANT

- The operation is guaranteed only for the optional SD memory cards and USB drives. The operation of storage media other than the options is not guaranteed.
- Use the instrument to format a new SD memory card or USB drive. If the media are formatted with a PC, the realtime saving may not be completed in time.
- Check that the write protect (write inhibit) of the SD memory card is disabled.
- Follow the procedure below to remove an SD memory card and USB drive from the instrument.

## Installing and removing an SD memory card

### Installing an SD memory card

- 1** Turn an SD memory card with the surface marked with “▲” facing left, and insert the card into the SD card slot.
- 2** Insert the SD memory card until the card is locked with a click.

### Removing the SD memory card

- 1** Make sure that the instrument is not accessing (saving, loading, etc.) the SD memory card.  
Confirm that the ACCESS LED is turned OFF.
- 2** Press and release the SD memory card. When the card is partially pushed out, pinch the card and pull it out.

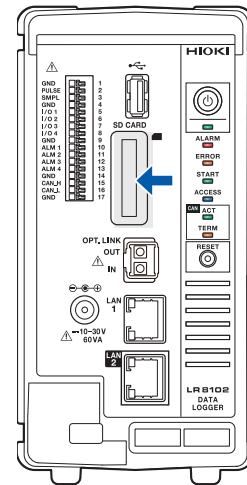

## Installing and removing a USB drive

### Installing a USB drive

- 1** Check the connection between the USB drive and the USB connector.
- 2** Insert the USB drive completely.

### Removing the USB drive

- 1** Make sure that the instrument is not accessing (saving, loading, etc.) the USB drive.  
Confirm that the ACCESS LED is turned OFF.
- 2** Pull out the USB drive.

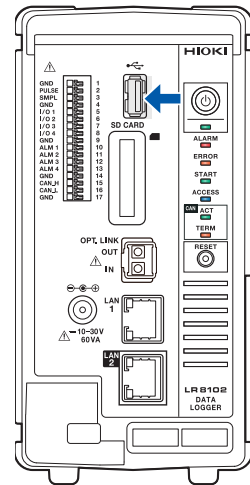

# 2

Connection (Preparation for Measurements)

## 2.8 Setting and Connecting the LAN

The instrument and a PC can be connected using a LAN cable.

### You can perform the following with LAN1

- Record and observe the settings of the instrument and the measurement data with Logger Utility. (p.249)
- Remotely operate the instrument (setting, data acquisition, screen monitoring, etc.) using a standard browser, such as Microsoft Edge (HTTP server). (p.251)
- Download files from the media (SD memory card and USB drive) to the PC (FTP server). (p.262)
- Automatically send waveform data saved in the media of the instrument to the network or the FTP server of the remote PC (FTP client). (p.264)
- Control the instrument using communication commands. (p.77)
- Control the instrument using XCP on Ethernet (TCP). (p.277)

### You can perform the following with LAN2 (LR8102 only)

- Output the measurement data based on the UDP. (p.285)
- Control the instrument using XCP on Ethernet (UDP). (p.277)

#### **IMPORTANT**

Be sure to configure the LAN settings before connecting the instrument to the network. If you change the settings while the instrument is connected to a network, the instrument may have the same IP address as another device on the LAN, causing incorrect address information to be sent to the LAN.

## Checking before connection

The settings are different when connecting the instrument to an existing network and when connecting one instrument to one PC.

### When connecting the instrument to an existing network

You must first have the network system administrator (department) allocate the following parameters. Ensure that the instrument uses a unique IP address that is not being used by any other device on the network.

|   |   |
|---|---|
| <b>DHCP server</b>                              | DHCP server: Used/not used  |
| <b>Host name<br/>IP address<br/>Subnet mask</b> | Host name<br>IP address<br>Subnet mask: ____:____:____:____<br>(IP address and subnet mask are not required when using DHCP server)   |
| <b>Port</b>                                     | <p><b>LAN1</b><br/>TCP/IP port number to be used: ____X (default 880x)<br/>Specify at least the first 3 digits of the 4 or 5 digits. The last digit is used and reserved for the instrument<br/>(The last digit: 0 for Logger Utility, 2 for the communication commands, 5 for XCP on Ethernet)<br/>Specify when the default setting (8800 to 8809) is not available</p> <div style="border: 1px solid black; padding: 5px;"> <p><b>Example of port number (with 880x default setting)</b><br/>Communication command: 8802 (Use this port for command control)<br/>Logger Utility: 8800<br/>XCP on Ethernet: 8805</p> </div> <p><b>LAN2</b><br/>UDP/IP port number to be used: ____X (default 880X)<br/>Specify at least the first 3 digits of the 4 or 5 digits. The last digit is used and reserved for the instrument<br/>(The last digit: 1 for the measurement data output, 5 for XCP on Ethernet)<br/>Specify when the default setting (8800 to 8809) is not available</p> <div style="border: 1px solid black; padding: 5px;"> <p><b>Example of port number (with 880x default setting)</b><br/>Measurement data output: 8801<br/>XCP on Ethernet: 8805</p> </div> |
| <b>Gateway</b>                                  | Gateway: Used/not used<br>IP address (when used): ____:____:____:____<br>(Setting is not required when using DHCP server, because the address is obtained from the server.)   |
| <b>DNS</b>                                      | DNS: used/not used<br>IP address (when used): ____:____:____:____<br>(Setting is not required when using DHCP server, because the address is obtained from the server.)   |

**When connecting one instrument and one PC (local network without external connection)**

The following address is recommended if there is no administrator or the setting is discretionary.  
Setting example

|                    |          |   |
|--------------------|----------|---|
| <b>DHCP server</b> |          | OFF   |
| <b>Host name</b>   |          | Discretionary setting (must be a unique name) |
| <b>IP address</b>  | PC       | 192.168.1.1                                   |
|                    | Logger 1 | 192.168.1.2                                   |
|                    | Logger 2 | 192.168.1.3 (numbered consecutively)          |
|                    | ↓        | ↓   |
| <b>Subnet mask</b> |          | 255.255.255.0                                 |
| <b>Port</b>        |          | 880X  |
| <b>Gateway</b>     |          | OFF   |
| <b>DNS</b>         |          | OFF   |

**Parameter**

|  |  |
|--|--|
| <b>DHCP server</b> (Dynamic Host Configuration Protocol) is used | DHCP is a method by which devices can automatically acquire and configure themselves with an IP address and other information.<br>When the DHCP server is enabled and the server is operating on the same network as the instrument, the instrument can automatically acquire and configure the IP address, subnet mask, and gateway.  |
| <b>Host name</b>   | This name represents the instrument on the network. Ensure that the instrument uses a unique name that is not being used by any other device on the network.<br>Since the instrument does not support dynamic DNS, the host name setting is not registered in the DNS.   |
| <b>IP address</b>  | The IP address is used to identify individual devices that are connected to the network.<br>Ensure that the instrument uses a unique name that is not being used by any other device on the network. If the DHCP server is enabled, the setting will be configured automatically using the server.   |
| <b>Subnet mask</b>   | The subnet mask is used to separate the IP address into the portion that indicates the network and the portion that indicates the device.<br>Ensure that the instrument uses the same subnet mask that is being used by other devices on the same network. If the DHCP server is enabled, the setting will be configured automatically using the server.   |
| <b>Gateway IP address</b>  | <ul style="list-style-type: none"> <li>When connecting the instrument to a network<br/>When the PC to be used (communicating device) is on a different network than the network with which the instrument is connected, set this parameter to <b>[ON]</b> and specify the device that serves as the gateway.<br/>When the PC is on the same network, generally use the same setting as the default gateway setting of the PC.</li> <li>When connecting one instrument and one PC<br/>Set this parameter to <b>[OFF]</b> when they are connected to the same hub.<br/>If the DHCP server is enabled, the setting will be obtained from the server.</li> </ul> |
| <b>DNS</b> (Domain Name System)                                  | If the DNS is enabled, the communication partner can be specified with its name instead of the IP address. (The IP addresses are difficult to remember because they are a series of numbers. It is easier if devices can be specified with their names instead of the IP addresses.)<br>If a server that allows you to obtain the IP addresses using the names is operating on the network, the IP address of the communication partner can be looked up from the name by querying the server. If the DHCP server is enabled, the setting will be obtained from the server.  |

## Network settings on PC

The setting method is the same for the case when connecting one instrument and one PC and the case when connecting one PC and multiple instruments via a hub.

The following network is assumed here.

- IP address: 192.168.1.0/24 (network address)  
or 192.168.1.1 (private IP address\*<sup>1</sup>)
- Subnet mask: 255.255.255.0

\*1. You may set the IP address as desired. However, a private IP address is recommended.

### For Windows 10 or Windows 11

- 1 Display the network connections from [Control Panel] > [Network and Sharing Center] > [Change adapter settings].
- 2 Right-click the icon of the adapter to be used for communications (named [Local Area Connection], [Ethernet], etc.), and then select [Properties].
- 3 Select [Internet Protocol Version 4 (TCP/IPv4)], and then click [Properties].

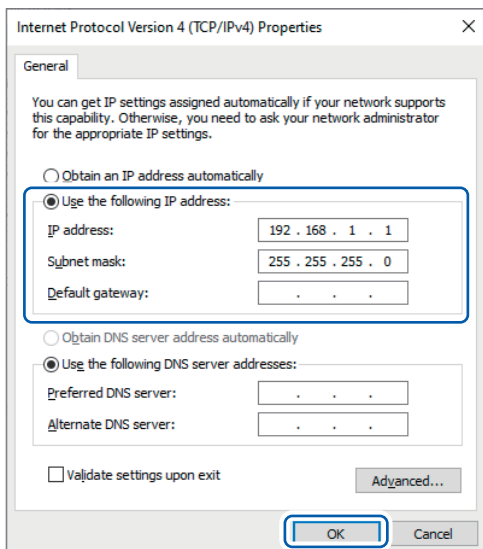
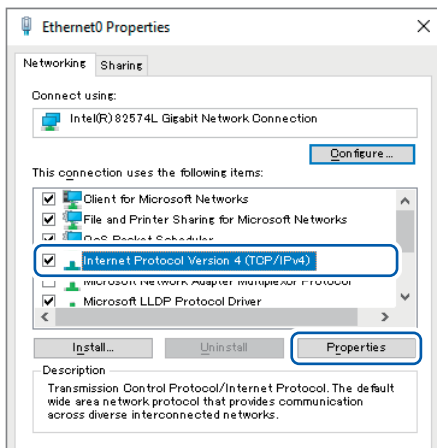

- 4 Enter [IP address] and [Subnet mask], then click [OK].

## Workflow for LAN settings

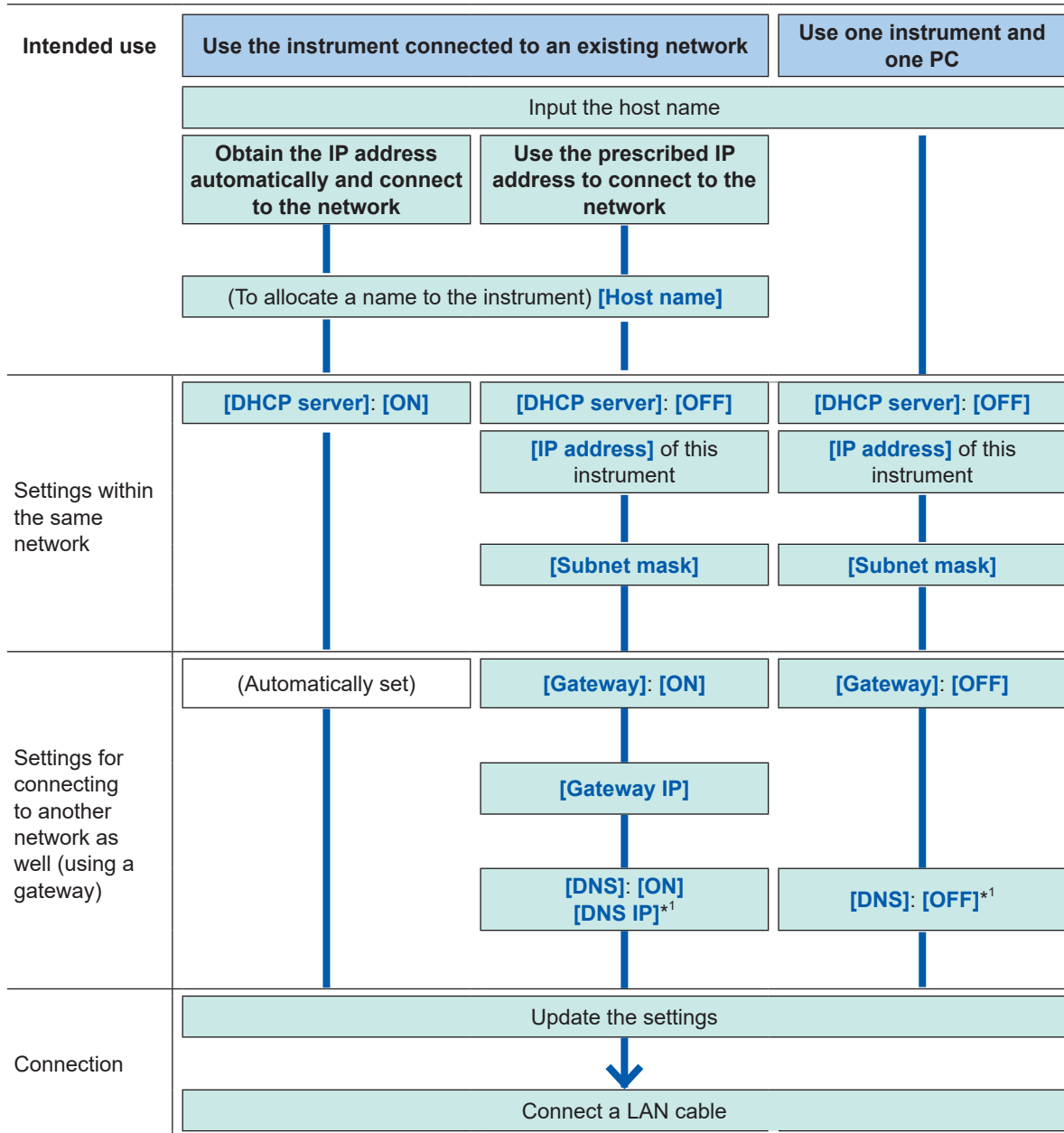

\*1. LAN1 only



## Configuring the settings for LAN1

Configure the following settings to perform the LAN communications. (p.77)

Update the LAN1 settings.

### IMPORTANT

The LAN1 settings will not be updated until this command is executed.  
Execute the command after completing the LAN1 settings.

| Settings |         |                                |
|----------|---------|--------------------------------|
| Syntax   | Command | :SYSTem:COMMunicate:LAN:UPDate |
| Example  |         | :SYSTem:COMMunicate:LAN:UPDate |

### DHCP server

When the DHCP server is set to ON, the IP address and the subnet mask can be obtained automatically. For **PREParation?**, the setting made before the update of the LAN1 settings is returned.

| Settings         |                             |   |
|------------------|-----------------------------|---|
| Syntax           | Command                     | :SYSTem:COMMunicate:LAN:DHCP A\$  |
| Example          |                             | :SYSTem:COMMunicate:LAN:DHCP ON<br>:SYSTem:COMMunicate:LAN:UPDate                                   |
| Query            |                             |   |
| Syntax           | Query                       | :SYSTem:COMMunicate:LAN:DHCP?<br>:SYSTem:COMMunicate:LAN:DHCP:PREParation?                          |
|                  | Response                    | A\$   |
| Example          |                             | :SYSTem:COMMunicate:LAN:DHCP?<br>(Response) :SYSTEM:COMMUNICATE:LAN:DHCP ON (When the header is ON) |
| Parameter        |                             |   |
| A\$ = OFF,ON     |                             |   |
| OFF <sup>□</sup> | Disables the DHCP function. |   |
| ON               | Enables the DHCP function.  |   |

### Host name

For **PREParation?**, the setting made before the update of the LAN1 settings is returned.

| Settings  |          |  |
|---|----------|--|
| Syntax  | Command  | :SYSTem:COMMunicate:LAN:HOSTname "A\$"   |
| Example   |          | :SYSTem:COMMunicate:LAN:HOSTname "LOGGER"<br>:SYSTem:COMMunicate:LAN:UPDate  |
| Query   |          |  |
| Syntax  | Query    | :SYSTem:COMMunicate:LAN:HOSTname?<br>:SYSTem:COMMunicate:LAN:HOSTname:PREParation?                                   |
|   | Response | "A\$"  |
| Example   |          | :SYSTem:COMMunicate:LAN:HOSTname?<br>(Response) :SYSTEM:COMMUNICATE:LAN:HOSTNAME "LOGGER"<br>(When the header is ON) |
| Parameter   |          |  |
| A\$ = Character string of host name (up to 12 single-byte characters) |          |  |

### IP address

The IP address is used to identify individual devices that are connected to the network. Ensure that the instrument uses a unique name that is not being used by any other device on the network. If the DHCP server is enabled, the setting will be configured automatically using the server.

For, [PREParation?](#), the setting made before the update of the LAN1 settings is returned.

| Settings         |          |   |
|------------------|----------|---|
| <b>Syntax</b>    | Command  | <code>:SYSTem:COMMunicate:LAN:IPADdress ip1,ip2,ip3,ip4</code>  |
| <b>Example</b>   |          | <code>:SYSTem:COMMunicate:LAN:IPADdress 192,168,1,100</code><br><code>:SYSTem:COMMunicate:LAN:UPDate</code>   |
| Query            |          |   |
| <b>Syntax</b>    | Query    | <code>:SYSTem:COMMunicate:LAN:IPADdress?</code><br><code>:SYSTem:COMMunicate:LAN:IPADdress:PREParation?</code>  |
|                  | Response | <code>ip1&lt;NR1&gt;,ip2&lt;NR1&gt;,ip3&lt;NR1&gt;,ip4&lt;NR1&gt;</code>  |
| <b>Example</b>   |          | <code>:SYSTem:COMMunicate:LAN:IPADdress?</code><br>(Response) <code>:SYSTEM:COMMUNICATE:LAN:IPADDRESS 192,168,1,100</code><br>(When the header is ON) |
| Parameter        |          |   |
| <code>ip1</code> | 0 to 255 |   |
| <code>ip2</code> | 0 to 255 |   |
| <code>ip3</code> | 0 to 255 |   |
| <code>ip4</code> | 0 to 255 |   |

### Subnet mask

The subnet mask is used to separate the IP address into the portion that indicates the network and the portion that indicates the device.

Ensure that the instrument uses the same subnet mask that is being used by other devices on the same network. If the DHCP server is enabled, the setting will be configured automatically using the server.

[PREParation?](#), the setting made before the update of the LAN1 settings is returned.

| Settings           |          |   |
|--------------------|----------|---|
| <b>Syntax</b>      | Command  | <code>:SYSTem:COMMunicate:LAN:SMASk mask1,mask2,mask3,mask4</code>  |
| <b>Example</b>     |          | <code>:SYSTem:COMMunicate:LAN:SMASk 255,255,255,0</code><br><code>:SYSTem:COMMunicate:LAN:UPDate</code>                                       |
| Query              |          |   |
| <b>Syntax</b>      | Query    | <code>:SYSTem:COMMunicate:LAN:SMASk?</code><br><code>:SYSTem:COMMunicate:LAN:SMASk:PREParation?</code>  |
|                    | Response | <code>mask1&lt;NR1&gt;mask2&lt;NR1&gt;,mask3&lt;NR1&gt;,mask4&lt;NR1&gt;</code>   |
| <b>Example</b>     |          | <code>:SYSTem:COMMunicate:LAN:SMASk?</code><br>(Response) <code>:SYSTEM:COMMUNICATE:LAN:SMASK 255,255,255,0</code><br>(When the header is ON) |
| Parameter          |          |   |
| <code>mask1</code> | 0 to 255 |   |
| <code>mask2</code> | 0 to 255 |   |
| <code>mask3</code> | 0 to 255 |   |
| <code>mask4</code> | 0 to 255 |   |

## Port

The last digit is used by the LAN1 system.

Example: No matter which number between 8800 and 8809 is specified, 8802 is the communication command port.

(The last digit: 0 for Logger Utility, 2 for the communication commands, 5 for XCP on Ethernet)

For **PREParation?**, the setting made before the update of the LAN1 settings is returned.

| Settings           |          |  |
|--------------------|----------|--|
| Syntax             | Command  | :SYSTem:COMMunicate:LAN:CONTRol no   |
| Example            |          | :SYSTem:COMMunicate:LAN:CONTRol 8800<br>:SYSTem:COMMunicate:LAN:UPDate   |
| Query              |          |  |
| Syntax             | Query    | :SYSTem:COMMunicate:LAN:CONTRol?<br>:SYSTem:COMMunicate:LAN:CONTRol:PREParation?                               |
|                    | Response | no   |
| Example            |          | :SYSTem:COMMunicate:LAN:CONTRol?<br>(Response) :SYSTEM:COMMUNICATE:LAN:CONTROL 8800<br>(When the header is ON) |
| Parameter          |          |  |
| no = 1020 to 65520 |          |  |

## Gateway IP

If the DHCP server is set to **ON**, the setting will be configured automatically.

Setting 0,0,0,0 disables the use of the Gateway.

For **PREParation?**, the setting made before the update of the LAN1 settings is returned.

| Settings  |          |   |
|-----------|----------|---|
| Syntax    | Command  | :SYSTem:COMMunicate:LAN:GATeway ip1,ip2,ip3,ip4   |
| Example   |          | :SYSTem:COMMunicate:LAN:GATeway 192,168,1,100<br>:SYSTem:COMMunicate:LAN:UPDate   |
| Query     |          |   |
| Syntax    | Query    | :SYSTem:COMMunicate:LAN:GATeway?<br>:SYSTem:COMMunicate:LAN:GATeway:PREParation?  |
|           | Response | ip1<NR1>, ip2<NR1>, ip3<NR1>, ip4<NR1>  |
| Example   |          | :SYSTem:COMMunicate:LAN:GATeway?<br>(Response) :SYSTEM:COMMUNICATE:LAN:GATEWAY 192,168,1,100<br>(When the header is ON) |
| Parameter |          |   |
| ip1       | 0 to 255 |   |
| ip2       | 0 to 255 |   |
| ip3       | 0 to 255 |   |
| ip4       | 0 to 255 |   |

## DNS

Setting 0,0,0,0 disables the use of the DNS.

For **PREparation?**, the setting made before the update of the LAN1 settings is returned.

| Settings       |          |   |
|----------------|----------|---|
| <b>Syntax</b>  | Command  | <code>:SYSTem:COMMunicate:LAN:DNS ip1,ip2,ip3,ip4</code>  |
| <b>Example</b> |          | <code>:SYSTem:COMMunicate:LAN:DNS 192,168,1,100</code><br><code>:SYSTem:COMMunicate:LAN:UPDate</code>                                     |
| Query          |          |   |
| <b>Syntax</b>  | Query    | <code>:SYSTem:COMMunicate:LAN:DNS?</code><br><code>:SYSTem:COMMunicate:LAN:DNS:PREparation?</code>  |
|                | Response | <code>ip1&lt;NR1&gt;,ip2&lt;NR1&gt;,ip3&lt;NR1&gt;,ip4&lt;NR1&gt;</code>  |
| <b>Example</b> |          | <code>:SYSTem:COMMunicate:LAN:DNS?</code><br>(Response) <code>:SYSTEM:COMMUNICATE:LAN:DNS 192,168,1,100</code><br>(When the header is ON) |
| Parameter      |          |   |
| <b>ip1</b>     |          | 0 to 255  |
| <b>ip2</b>     |          | 0 to 255  |
| <b>ip3</b>     |          | 0 to 255  |
| <b>ip4</b>     |          | 0 to 255  |

## Setting example

- When connecting one instrument and one PC

|             |               |
|-------------|---------------|
| DHCP server | OFF           |
| Host name   | LOGGER        |
| IP address  | 192.168.1.2   |
| Subnet mask | 255.255.255.0 |
| Port        | 880X          |
| Gateway     | OFF           |
| DNS         | OFF           |

- When connecting one PC and multiple instruments via a hub.

A case of involving a local network without an external connection is explained here.

A private IP address is recommended.

Configure as follows to ensure that the instrument uses a unique host name and IP address that are not being used by any other device on the network.

Instrument unit 1

|            |             |
|------------|-------------|
| Host name  | LOGGER      |
| IP address | 192.168.1.2 |

Instrument unit 2

|            |             |
|------------|-------------|
| Host name  | LOGGER2     |
| IP address | 192.168.1.3 |

Instrument unit 3

|            |             |
|------------|-------------|
| Host name  | LOGGER3     |
| IP address | 192.168.1.4 |

Common settings

|             |               |
|-------------|---------------|
| DHCP server | OFF           |
| Subnet mask | 255.255.255.0 |
| Port        | 880X          |
| Gateway     | OFF           |

## Connecting the instrument and a PC via LAN

Connect the instrument and a PC with a LAN cable.

### CAUTION



- **Do not unplug the LAN cable while the instrument is sending or receiving data.**

Doing so could damage the instrument and the PC.

- **Turn OFF the instrument and PC before connecting or disconnecting a LAN cable.**

Failure to do so could damage the instrument and the PC being connected or cause them to malfunction.

- **Use the same ground for the instrument and the PC.**



When a LAN cable is connected to the instrument with a potential difference between the ground circuits of the instrument and the PC, the instrument and PC may be damaged or malfunction.

- **If routing a LAN cable outdoors or using a LAN cable longer than 30 m, attach a LAN surge protector or other suitable protective device.**

Failure to do so could cause damage to the instrument due to increased susceptibility to the effects of induced lightning.

### LAN port of the instrument

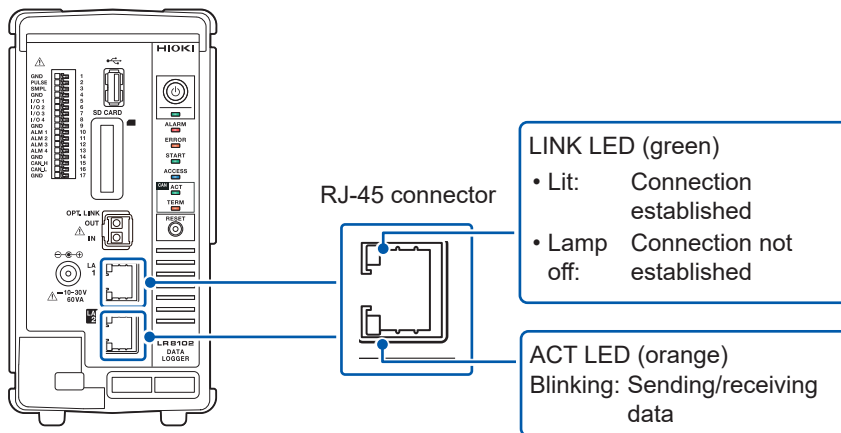

The LINK LED lights up when the instrument is properly connected to the network and available. If the LED does not light up, the instrument or connected devices may have a problem or the LAN cable may be broken.

### When connecting one instrument and one PC

Required item: 9642 LAN Cable (1 piece)

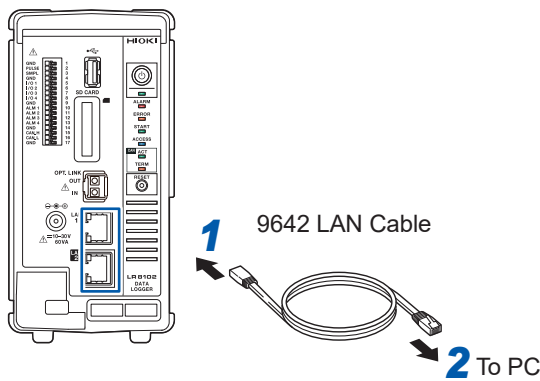

- 1** Connect the 9642 LAN Cable to the LAN1 or LAN2 port of the instrument.
- 2** Connect the 9642 LAN Cable to the PC's LAN connector.

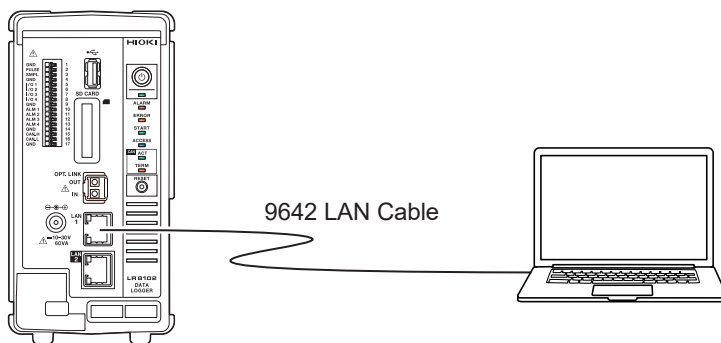

**2**

Connection (Preparation for Measurements)

### When connecting one PC and multiple instruments via a hub.

Required items: 9642 LAN Cable (2 pieces), hub

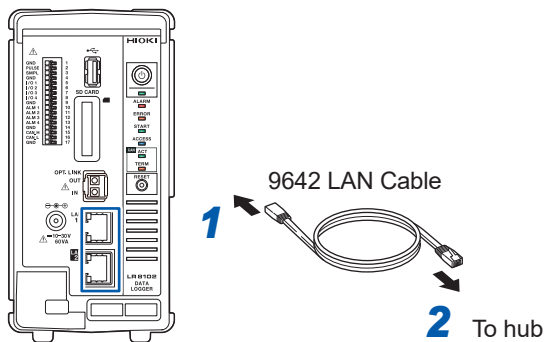

- 1** Connect the 9642 LAN Cable to the LAN1 or LAN2 port of the instrument.
- 2** Connect the 9642 LAN Cable to the hub's LAN connector.

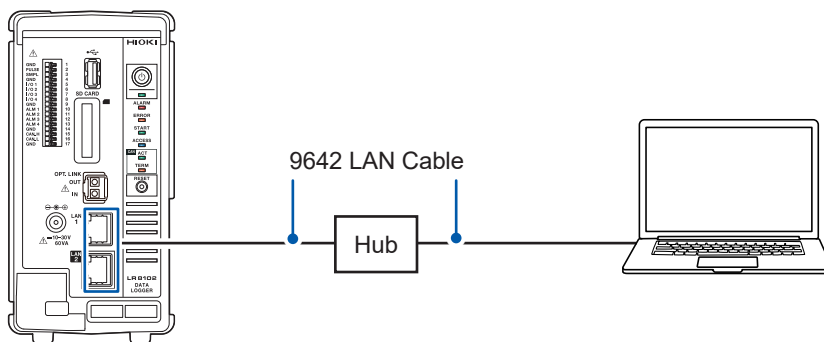

## Default connection settings for LAN1

The default IP address of the instrument on LAN1 is 192.168.1.2.

There are three methods to change the IP address on LAN1 and the communication settings of the instrument as follows.

- Use the HTTP server
- Use the communication commands.
- Use Logger Utility.

### To change the settings using the HTTP server

See “12.2 Remotely Operating the Instrument through the HTTP Server” (p. 251).

### To change the settings using the communication commands.

**Example: Connecting one instrument and one PC with the minimum settings required**

Required items: 9642 LAN Cable (1 piece), PC with configurable IP address

Change the IP address of the PC to 192.168.1.1

Send the following communication commands from the PC (communication command port 8802)

#### 1 Set the IP address of the instrument.

The IP address is used to identify individual devices that are connected to the network. Ensure that the instrument uses a unique name that is not being used by any other device on the network. If the DHCP server is enabled, the setting will be configured automatically using the server.

| Settings         |          |   |
|------------------|----------|---|
| <b>Syntax</b>    | Command  | <code>:SYSTem:COMMunicate:LAN:IPAddress ip1,ip2,ip3,ip4</code>  |
| <b>Example</b>   |          | <code>:SYSTem:COMMunicate:LAN:IPAddress 192,168,1,100</code><br><code>:SYSTem:COMMunicate:LAN:UPDate</code>   |
| Query            |          |   |
| <b>Syntax</b>    | Query    | <code>:SYSTem:COMMunicate:LAN:IPAddress?</code>   |
|                  | Response | <code>ip1&lt;NR1&gt;,ip2&lt;NR1&gt;,ip3&lt;NR1&gt;,ip4&lt;NR1&gt;</code>  |
| <b>Example</b>   |          | <code>:SYSTem:COMMunicate:LAN:IPAddress?</code><br>(Response) <code>:SYSTEM:COMMUNICATE:LAN:IPADDRESS 192,168,1,100</code><br>(When the header is ON) |
| Parameter        |          |   |
| <code>ip1</code> | 0 to 255 |   |
| <code>ip2</code> | 0 to 255 |   |
| <code>ip3</code> | 0 to 255 |   |
| <code>ip4</code> | 0 to 255 |   |



## 2 Set the subnet mask of LAN1.

The subnet mask is used to separate the IP address into the portion that indicates the network and the portion that indicates the device.

Ensure that the instrument uses the same subnet mask that is being used by other devices on the same network. If the DHCP server is enabled, the setting will be configured automatically using the server.

| Settings           |   |  |
|--------------------|---|--|
| Syntax             | Command   | <code>:SYSTem:COMMunicate:LAN:SMASK mask1,mask2,mask3,mask4</code>               |
| Example            | <code>:SYSTem:COMMunicate:LAN:SMASK 255,255,255,0</code><br><code>:SYSTem:COMMunicate:LAN:UPDate</code>                                       |  |
| Query              |   |  |
| Syntax             | Query   | <code>:SYSTem:COMMunicate:LAN:SMASK?</code>                                      |
|                    | Response  | <code>mask1&lt;NR1&gt;,mask2&lt;NR1&gt;,mask3&lt;NR1&gt;,mask4&lt;NR1&gt;</code> |
| Example            | <code>:SYSTem:COMMunicate:LAN:SMASK?</code><br>(Response) <code>:SYSTEM:COMMUNICATE:LAN:SMASK 255,255,255,0</code><br>(When the header is ON) |  |
| Parameter          |   |  |
| <code>mask1</code> | 0 to 255  |  |
| <code>mask2</code> | 0 to 255  |  |
| <code>mask3</code> | 0 to 255  |  |
| <code>mask4</code> | 0 to 255  |  |

## 3 Updates the settings of LAN1.

| Settings |   |   |
|----------|---|---|
| Syntax   | Command                                     | <code>:SYSTem:COMMunicate:LAN:UPDate</code> |
| Example  | <code>:SYSTem:COMMunicate:LAN:UPDate</code> |   |

## 4 Change the PC to be used or change the IP address of the PC (as needed).

- If the intended use of the PC is only to set the IP address of the instrument, replace the PC as needed.
- Change the IP address of the PC as well if it becomes necessary as a result of setting the IP address of the instrument.

### Changing the settings using Logger Utility

Required items: 9642 LAN Cable (1 piece), PC on which Logger Utility can be installed

#### 1 Install Logger Utility on the PC.

Refer to the "Logger Utility Instruction Manual" (PDF file) on the provided DVD.

#### 2 Start up Logger Utility.

Click [\[All Programs\]](#) > [\[HIOKI\]](#) > [\[Logger Utility\]](#).

- 3** Click **[Setting]**.  
The settings screen is displayed.
- 4** Check the **[LAN]** checkbox.
- 5** Click **[Search]**.

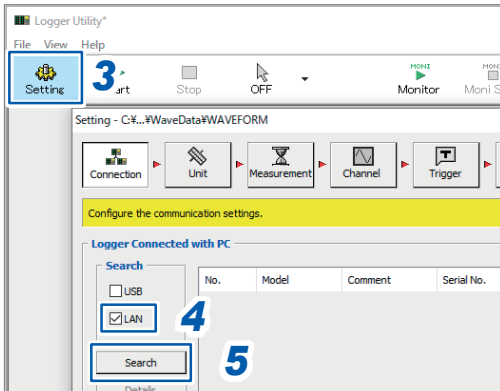

- 6** Select the target instrument.
- 7** Click **[Details]**.  
The **[Detail Information]** dialog box is displayed.

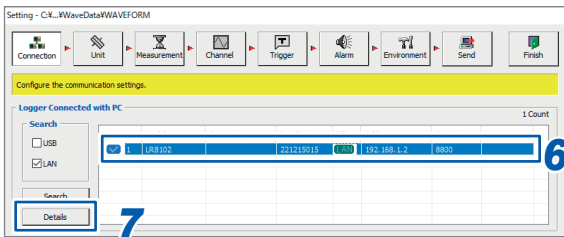

- 8** Configure the network settings and click **[Send]**.

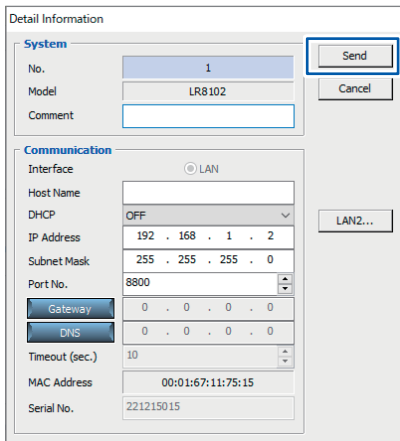

- 9** Change the IP address of the PC. (as needed).

**IMPORTANT**

If the DHCP setting for the instrument is set to ON in an environment where the DHCP server is not operating, the instrument cannot be searched for with Logger Utility. Connect the instrument in an environment with the DHCP server operating, or fully reset the instrument.

## When the LAN communications cannot be established.

### The cable is not connected properly

- There may be a contact failure in the connector. Disconnect and then connect the cable again.
- When the cable is connected properly, the LINK LED of the **LAN1** or **LAN2** port of the instrument lights up.

### The IP address of the PC is not correct

The IP address, subnet mask, and gateway address of the network interface of the PC can be checked.

- 1 Press the Windows and R keys simultaneously.**  
The **[Run]** dialog box is displayed.
- 2 Enter “CMD” and press the Enter key.**  
The **[CMD.exe]** window will open.
- 3 After the cursor starts blinking, enter [ipconfig/all] and press the Enter key.**

### The communications between the instrument and the PC cannot be established

If the IP addresses of the instrument and the PC are set correctly, you can use the ping protocol to check whether the transmission from the PC reaches the instrument.

- 1 Press the Windows and R keys simultaneously.**  
The **[Run]** dialog box is displayed.
- 2 Enter “CMD” and press the Enter key.**  
The **[CMD.exe]** window will open.
- 3 After the cursor starts blinking, enter [ping XXX.XXX.X.X] (IP address of the host to be checked) and press the Enter key.**

The host name can also be used in an environment where the DNS is functioning normally. For example, enter **[ping 192.168.1.2]** if the IP address of the instrument is **[192.168.1.2]**.

- 4 Check the contents displayed on the PC screen.**

The communications are normal if the following is displayed on the PC screen. “Time” represents the time spent for the communications.

Pinging 192.168.1.2 with 32 bytes of data:

Reply from 192.168.1.2: bytes=32 time<10ms TTL=32

Reply from 192.168.1.2: bytes=32 time<10ms TTL=32

Reply from 192.168.1.2: bytes=32 time<10ms TTL=32

Reply from 192.168.1.2: bytes=32 time=1ms TTL=32

The communications are not normal if the following is displayed on the PC screen. Check the cable connection.

Pinging 192.168.1.2 with 32 bytes of data:

Reply from 192.168.1.2: Host is down.

Reply from 192.168.1.2: Host is down.

Reply from 192.168.1.2: Host is down.

Reply from 192.168.1.2: Host is down.



## 3.1 Controlling the Instrument Using Communication Commands

Before starting the measurement, set the measurement conditions using the communication commands.

By sending the communication commands from a PC, you can control the instrument and acquire the status of the instrument.

See “Communication Method” (p. 19).

Use a LAN cable to connect the instrument and a PC.

See “Connecting the instrument and a PC via LAN” (p. 70) and See “2.8 Setting and Connecting the LAN” (p. 60).

For the list of communication commands, see the “Communication Command Instruction Manual” on the provided DVD.

## Standard commands specified by IEEE 488.2

### 1 Clear the status byte and related queues (excluding the output queue).

The event register corresponding to each bit of the Status Byte Register is cleared.

The Status Byte Register is also cleared.

Since the output queue is not cleared, MAV (bit 4) of the status byte is not affected.

| Settings |         |      |
|----------|---------|------|
| Syntax   | Command | *CLS |
| Example  | *CLS    |      |

### 2 Read out and clear the Standard Event Status Register (SESR).

| Query   |  |        |
|---|--|--------|
| Syntax  | Query  | *ESR?  |
|   | Response   | A<NR1> |
| Example   | *ESR?<br>(Response) *ESR 0 (When the header is ON) |        |
| Parameter   |  |        |
| A = 0 to 255  |  |        |
| The content of the SESR is returned with NR1 and the SESR is cleared. |  |        |

### 3 Query the device ID (identification code).

| Query                   |  |                    |
|-------------------------|--|--------------------|
| Syntax                  | Query  | *IDN?              |
|                         | Response   | A\$, B\$, C\$, D\$ |
| Example                 | *IDN?<br>(Response) *IDN HIOKI, LR8101, 123456789, V1.00 (When the header is ON) |                    |
| Parameter               |  |                    |
| A\$ = Manufacturer name |  |                    |
| B\$ = Model name        |  |                    |
| C\$ = Serial number     |  |                    |
| D\$ = Software version  |  |                    |

### 4 Set LSB of the SESR after all operations are completed.

Set LSB (bit 0) of the SESR (Standard Event Status Register) once the commands before the \*OPC command are processed, among the transmitted commands.

The following commands will wait for processing to be completed.

- Stop measurement (:STOP)  
To wait for the measurement to be stopped, the :STOP command needs to be sent 2 times.
- Load hold data (:MEMORY:GETReal)
- Initialize instrument (\*RST)

| Settings |  |      |
|----------|--|------|
| Syntax   | Command  | *OPC |
| Example  | A\$; *OPC<br>After the processing of command A\$ is completed, *OPC is executed. |      |

**5 Return 1 in ASCII after all operations are completed.**

Return 1 in ASCII once the commands before the **\*OPC?** command are processed, among the transmitted commands.

The following commands will wait for processing to be completed.

- Stop measurement (**:STOP**)  
To wait for the measurement to be stopped, the **:STOP** command needs to be sent 2 times.
- Load hold data (**:MEMORY:GETReal**)
- Initialize instrument (**\*RST**)

| Query        |   |                     |
|--------------|---|---------------------|
| Syntax       | Query   | <b>*OPC?</b>        |
|              | Response  | <b>A&lt;NR1&gt;</b> |
| Example      | <b>A\$; *OPC?</b><br>After the processing of command <b>A\$</b> is completed, 1 in ASCII is returned.<br>(Response) <b>*OPC 1</b> (When the header is ON) |                     |
| Parameter    |   |                     |
| <b>A</b> = 1 |   |                     |

**6 Query the optional equipment of the instrument.**

Return the type of the modules installed. The responses are returned starting from module 1 in order.

| Query               |   |                     |
|---------------------|---|---------------------|
| Syntax              | Query   | <b>*OPT?</b>        |
|                     | Response  | <b>A&lt;NR1&gt;</b> |
| Example             | <b>A\$; *OPT?</b><br>(Response) <b>*OPT 1,1,1,1,1,3,3,3,3,3</b> (When the header is ON) |                     |
| Parameter           |   |                     |
| <b>Ax</b> = 0, 1, 3 |   |                     |
| 0                   | No module   |                     |
| 1                   | M7100 Voltage/Temp Module   |                     |
| 3                   | M7102 Voltage/Temp Module   |                     |

**7 Initialize the instrument.**

Data related to the LAN communications will not be cleared.

(Event register, input buffer, output queue)

It takes time to process the **\*RST** command.

| Settings |             |             |
|----------|-------------|-------------|
| Syntax   | Command     | <b>*RST</b> |
| Example  | <b>*RST</b> |             |

**8 Read out the status byte.**

| Query               |   |                     |
|---------------------|---|---------------------|
| Syntax              | Query   | <b>*STB?</b>        |
|                     | Response  | <b>A&lt;NR1&gt;</b> |
| Example             | <b>*STB?</b><br>(Response) <b>*STB? 128</b> (When the header is ON) |                     |
| Parameter           |   |                     |
| <b>A</b> = 0 to 255 |   |                     |

## 9 Execute a quick ROM/RAM check and query the check result.

| Query   |  |                     |
|---|--|---------------------|
| Syntax  | Query  | <b>*TST?</b>        |
|   | Response   | <b>A&lt;NR1&gt;</b> |
| Example   | <b>*TST?</b><br>(Response) <b>*TST 0</b> (When the header is ON) |                     |
| Parameter   |  |                     |
| <b>Ax</b> = 0, 1  |  |                     |
| The quick ROM/RAM check result of the instrument is returned with a numerical value in the NR1 format.<br><b>0</b> = Normal<br><b>1</b> = Error |  |                     |

To check more details  
See "Self-checks (Self-diagnosis)" (p. 235).

## 10 After the operation is completed, execute the subsequent commands.

Processing for the following commands will wait to be completed.

- Stop measurement (**:STOP**)  
To wait for the measurement to be stopped, the **:STOP** command needs to be sent 2 times.
- Load hold data (**:MEMory:GETReal**)
- Initialize instrument (**\*RST**)

| Settings |                           |             |
|----------|---------------------------|-------------|
| Syntax   | Command                   | <b>*WAI</b> |
| Example  | <b>A\$ ; *WAI ; *IDN?</b> |             |

## 11 Read out and clear Event Status Register 0 (ESR0).

| Query  |   |                     |
|--|---|---------------------|
| Syntax   | Query   | <b>:ESR0?</b>       |
|  | Response  | <b>A&lt;NR1&gt;</b> |
| Example  | <b>:ESR0?</b><br>(Response) <b>:ESR0? 0</b> (When the header is ON) |                     |
| Parameter  |   |                     |
| <b>A</b> = 0 to 255  |   |                     |
| Event Status Register 0 (ESR0) is read out.<br>The content of ESR0 is returned with NR1 and ESR0 is cleared. |   |                     |



## 3.2 Basic Operations and Queries

### 1 Query the status of the instrument.

| Query  |  |                           |
|--|--|---------------------------|
| Syntax   | Query  | <code>:STATUS?</code>     |
|  | Response   | <code>A&lt;NR1&gt;</code> |
| Example  | <code>:STATUS?</code><br>(Response) <code>:STATUS 3</code> (When the header is ON) |                           |
| Parameter  |  |                           |
| <code>A\$</code> = 0 to 63   |  |                           |
| The status of the instrument is returned with a numerical value in the NR1 format. For example, a response with 3 indicates that the instrument is recording and starting. |  |                           |
| <code>Bit0</code>  | Starting   |                           |
| <code>Bit1</code>  | Recording  |                           |
| <code>Bit2</code>  | The instrument is in the trigger standby state.                                    |                           |
| <code>Bit3</code>  | Waiting for pre-trigger  |                           |
| <code>Bit4</code>  | (Reserved)   |                           |
| <code>Bit5</code>  | Accessing file   |                           |

### 2 Query errors in the instrument.

| Query   |   |                      |
|---|---|----------------------|
| Syntax  | Query   | <code>:ERRor?</code> |
|   | Response  | <code>A\$</code>     |
| Example   | <code>:ERRor?</code><br>(Response) <code>:ERROR ERR_SY01</code> (When the header is ON) |                      |
| Parameter   |   |                      |
| <code>A\$</code> = Error number   |   |                      |
| The number of the error or warning that has sent in the instrument is returned.<br>If the <code>:ERRor?</code> query is issued immediately after an error occurs, the information on the previous error may be returned. In such a case, send the <code>:ERRor?</code> query again.<br>See "Error messages" (p. 352). |   |                      |

### 3 Set the header.

| Settings                                  |   |                          |
|---|---|--------------------------|
| Syntax                                    | Command   | <code>:HEADer A\$</code> |
| Example                                   | <code>:HEADer ON</code>   |                          |
| Query                                     |   |                          |
| Syntax                                    | Query   | <code>:HEADer?</code>    |
|   | Response  | <code>A\$</code>         |
| Example                                   | <code>:HEADer?</code><br>(Response) <code>:HEADER ON</code> (When the header is ON) |                          |
| Parameter                                 |   |                          |
| <code>A\$</code> = OFF, ON                |   |                          |
| <code>OFF</code> <input type="checkbox"/> | Do not attach any header to the response data for the queries and commands.         |                          |
| <code>ON</code>                           | Attach a header to the response data for the queries and commands.                  |                          |

## 3.3 Setting Measurement Conditions

Configure the basic settings of the measurement, including the recording interval and the recording time.

The details of the settings depend on the recording modes.

### Normal sampling

The sampling is performed at a timing synchronized with the internal clock of the logger to record the data.

#### 1 Set the recording mode to NORMAL.

| Settings                         |   |                                      |
|----------------------------------|---|--------------------------------------|
| Syntax                           | Command   | <code>:CONFigure:SAMPKind A\$</code> |
| Example                          | <code>:CONFigure:SAMPKind NORMAl</code>   |                                      |
| Query                            |   |                                      |
| Syntax                           | Query   | <code>:CONFigure:SAMPKind?</code>    |
|                                  | Response  | <code>A\$</code>                     |
| Example                          | <code>:CONFigure:SAMPKind?</code><br>(Response) <code>:CONFIGURE:SAMPKIND NORMAL</code> (When the header is ON) |                                      |
| Parameter                        |   |                                      |
| <code>A\$</code> = NORMAl, EXT   |   |                                      |
| <code>NORMAl</code> <sup>☑</sup> | The data are recorded in synchronization with the internal clock.   |                                      |
| <code>EXT</code>                 | The data are recorded in synchronization with an external clock.  |                                      |

#### 2 Set the interval to acquire the data.

Example: If the value is set to 10 ms, the data are acquired at intervals of 10 ms (100 times per second).

| Settings  |  |   |
|---|--|---|
| Syntax  | Command  | <code>:CONFigure:SAMPle A</code>                            |
| Example   | <code>:CONFigure:SAMPle 1E-2</code>  |   |
| Query   |  |   |
| Syntax  | Query  | <code>:CONFigure:SAMPle?</code>                             |
|   | Response   | <code>A&lt;NR3&gt;</code> (1 digit after the decimal point) |
| Example   | <code>:CONFigure:SAMPle?</code><br>(Response) <code>:CONFIGURE:SAMPLE 1.0E-02</code> (When the header is ON) |   |
| Parameter   |  |   |
| <code>A</code> = 5.0E-3 to 3.6E+3 (sec)   |  |   |
| 5 ms*1, 10 ms, 20 ms, 50 ms, 100 ms, 200 ms, 500 ms,<br>1 s, 2 s, 5 s, 10 s, 20 s, 30 s,<br>1 min, 2 min, 5 min, 10 min, 20 min, 30 min,<br>1 h   |  |   |
| *1. Can be set only when using M7100  |  |   |
| If a value not listed in the setting is specified and if there are ranges higher than the specified value, the nearest range is applied.<br>When an external sampling is used, 10 ms ( <code>1.0E-2</code> ) is returned. |  |   |

### 3 Set the recording time (max. 500 days).

The maximum recording time varies with the number of channels and the recording interval to be used.

If the continuous recording is specified, the measurement is continued until the **STOP** command is executed.

You can also stop the measurement using the trigger.

See “Set the behavior when the trigger is activated.” (p. 139).

If the maximum capacity of the internal buffer memory is exceeded, the measurement is continued while deleting old data in the internal buffer memory. Since the deleted data cannot be recovered, the auto-save operation is recommended.

See “Auto save (Realtime save)” (p. 164).

| Settings  |   |  |
|---|---|--|
| <b>Syntax</b>   | Command   | <code>:CONFigure:RETime day, hour, min, sec</code>                           |
| <b>Example</b>  | <code>:CONFigure:RETime 0,0,0,10</code>   |  |
| Query   |   |  |
| <b>Syntax</b>   | Query   | <code>:CONFigure:RETime?</code>  |
|   | Response  | <code>day&lt;NR1&gt;, hour&lt;NR1&gt;, min&lt;NR1&gt;, sec&lt;NR1&gt;</code> |
| <b>Example</b>  | <code>:CONFigure:RETime?</code><br>(Response) <code>:CONFigure:RETIME 0,0,0,10</code> (When the header is ON) |  |
| Parameter   |   |  |
| <b>day</b>  | 0 to 500 (days)   |  |
| <b>hour</b>   | 0 to 23 (hours)   |  |
| <b>min</b>  | 0 to 59 (minutes)   |  |
| <b>sec</b>  | 0 to 59 (seconds)   |  |
| The current setting of the recording time is returned with a numerical value in the NR1 format.<br>See “Data part” (p. 23). |   |  |
| The continuous recording is specified if all of the parameters are 0.   |   |  |

### 4 Configure the measurement stop setting.

Measurement can be stopped at the specified date and time. The recording is stopped as soon as the measurement is stopped.

After the measurement is started and before it is stopped, the recording is started or stopped according to the trigger conditions.

| Settings   |   |                                  |
|--|---|----------------------------------|
| <b>Syntax</b>  | Command   | <code>:CONFigure:STOP A\$</code> |
| <b>Example</b>   | <code>:CONFigure:STOP MANUAL</code>   |                                  |
| Query  |   |                                  |
| <b>Syntax</b>  | Query   | <code>:CONFigure:STOP?</code>    |
|  | Response  | <code>A\$</code>                 |
| <b>Example</b>   | <code>:CONFigure:STOP?</code><br>(Response) <code>:CONFigure:STOP MANUAL</code> (When the header is ON)   |                                  |
| Parameter  |   |                                  |
| <b>A\$</b> = MANUAL, TIME                                  |   |                                  |
| <b>MANUAL</b> <input type="checkbox"/>                     | Measurement is stopped with the <b>STOP</b> command or EXT. I/O.  |                                  |
| <b>TIME</b>  | Measurement is stopped at the specified date and time. (p.84)<br>Year - Month - Day Hour:Minute<br>Executing the <b>STOP</b> command during the measurement stops the measurement even if the stop time is specified. |                                  |
| When an external sampling is used, only MANUAL can be set. |   |                                  |

## 5 Set the measurement stop time.

You cannot set a time earlier than the measurement start time.

| Settings            |                   |   |
|---------------------|-------------------|---|
| Syntax              | Command           | <code>:CONFigure:STOPTime year,month,day,hour,minute</code>   |
| Example             |                   | <code>:CONFigure:STOPTime 24,1,2,12,34</code>   |
| Query               |                   |   |
| Syntax              | Query             | <code>:CONFigure:STOPTime?</code>   |
|                     | Response          | <code>year&lt;NR1&gt;,month&lt;NR1&gt;,day&lt;NR1&gt;hour&lt;NR1&gt;,minute&lt;NR1&gt;</code>                         |
| Example             |                   | <code>:CONFigure:STOPTime?</code><br>(Response) <code>:CONFIGURE:STOPTIME 24,1,2,12,34</code> (When the header is ON) |
| Parameter           |                   |   |
| <code>year</code>   | 21 to 37 (year)   |   |
| <code>month</code>  | 1 to 12 (month)   |   |
| <code>day</code>    | 1 to 31 (days)    |   |
| <code>hour</code>   | 0 to 23 (hours)   |   |
| <code>minute</code> | 0 to 59 (minutes) |   |

## External sampling

The sampling is performed at a timing synchronized with an external clock to record the data. When an external sampling is used, the following functions are disabled or settings are fixed.

- Data refresh interval: 0 (auto) cannot be set
- Stop: MANUAL only
- Pulse, logic channel: Measurement disabled
- Synchronized operation: Setting disabled
- Auto save - Folder splitting: OFF (Disable) only
- Auto save - File splitting: Function disabled
- Horizontal (time) axis display: SCALE (Number of data) only
- Pre-trigger: Function disabled
- Alarm type: Level and Window only
- Numerical - Time split calculation: OFF (Disable) only
- Waveform calculation - Reset time: OFF (Disable) only
- CAN measured value output, CAN terminal output: No time output

### 1 Set the recording mode.

| Settings            |  |                         |
|---------------------|--|-------------------------|
| Syntax              | Command  | :CONFigure:SAMPKind A\$ |
| Example             | :CONFigure:SAMPKind EXT  |                         |
| Query               |  |                         |
| Syntax              | Query  | :CONFigure:SAMPKind?    |
|                     | Response   | A\$                     |
| Example             | :CONFigure:SAMPKind?<br>(Response) :CONFIGURE:SAMPKIND EXT (When the header is ON) |                         |
| Parameter           |  |                         |
| A\$ = NORMAL, EXT   |  |                         |
| NORMAL <sup>☐</sup> | The data are recorded in synchronization with the internal clock.                  |                         |
| EXT                 | The data are recorded in synchronization with an external clock.                   |                         |

### 2 Set the number of samples.

| Settings            |  |                         |
|---------------------|--|-------------------------|
| Syntax              | Command  | :CONFigure:EXTRECSamp A |
| Example             | :CONFigure:EXTRECSamp 100  |                         |
| Query               |  |                         |
| Syntax              | Query  | :CONFigure:EXTRECSamp?  |
|                     | Response   | A<NR1>                  |
| Example             | :CONFigure:EXTRECSamp?<br>(Response) :CONFIGURE:EXTRECSAMP 100 (When the header is ON) |                         |
| Parameter           |  |                         |
| A = 1 to 1000000000 |  |                         |

See "11.3 Setting the External Sampling (SMPL)" (p. 248).



#### When measurement is performed consecutively without specifying the number of samples for external sampling

Set the continuous recording using the following command.

```
:CONFigure:RECTime 0,0,0,0
```

The setting for the number of samples is ignored.

## Common settings for the recording modes

### 1 Enter the title comment (optional).

See "Title comment" (p. 115) and "(3) Character string data" (p. 24).

| Settings   |          |  |
|--|----------|--|
| Syntax   | Command  | :COMMeNt:TITLe "A\$"   |
| Example  |          | :COMMeNt:TITLe "HIOKI"   |
| Query  |          |  |
| Syntax   | Query    | :COMMeNt:TITLe?  |
|  | Response | "A\$"  |
| Example  |          | :COMMeNt:TITLe?<br>(Response) :COMMeNt:TITLe "HIOKI" (When the header is ON) |
| Parameter  |          |  |
| A\$ = Character string of comment (up to 20 double-byte characters or 40 single-byte characters) |          |  |

### 2 Set whether or not to repeat the recording operation.

| Settings             |   |   |
|----------------------|---|---|
| Syntax               | Command   | :TRIGger:MODE A\$   |
| Example              |   | :TRIGger:MODE REPEat  |
| Query                |   |   |
| Syntax               | Query   | :TRIGger:MODE?  |
|                      | Response  | A\$   |
| Example              |   | :TRIGger:MODE?<br>(Response) :TRIGger:MODE REPEat (When the header is ON) |
| Parameter            |   |   |
| A\$ = SINGle, REPEat |   |   |
| SINGle <sup>☐</sup>  | Repetitive recording OFF<br>The measurement is completed with one recording.                              |   |
| REPEat               | Repetitive recording ON<br>The recording is repeated.<br>Executing the STOP command ends the measurement. |   |

### 3 Configure the measurement start setting.

Measurement can be started at the specified date and time. After the measurement is started, the recording is started according to the trigger settings.

After the measurement is started and before it is stopped, the recording is started or stopped according to the trigger conditions.

- Measurement start: The measurement is started and waiting for the trigger
- Recording started: The trigger is activated and the recording is started

| Settings                                   |  |                      |
|--|--|----------------------|
| Syntax                                     | Command  | :CONFigure:START A\$ |
| Example                                    | :CONFigure:START MANUAL  |                      |
| Query                                      |  |                      |
| Syntax                                     | Query  | :CONFigure:START?    |
|  | Response   | A\$                  |
| Example                                    | :CONFigure:START?<br>(Response) :CONFIGURE:START MANUAL (When the header is ON)  |                      |
| Parameter                                  |  |                      |
| A\$ = MANUAL, TIME                         |  |                      |
| MANUAL <input checked="" type="checkbox"/> | Measurement is started with the <b>START</b> command or EXT. I/O.  |                      |
| TIME                                       | Measurement is started at the specified date and time.<br>Year - Month - Day Hour:Minute<br>The <b>START</b> command keeps the measurement start on standby until the specified date and time.<br>If the <b>START</b> command is executed after the specified date and time, the measurement is started. |                      |

### 4 Set the measurement start time.

You cannot set a time later than the measurement stop time. (p. 84)

| Settings  |   |   |
|-----------|---|---|
| Syntax    | Command   | :CONFigure:STARTTime year,month,day,hour,minute     |
| Example   | :CONFigure:STARTTime 24,1,2,12,34   |   |
| Query     |   |   |
| Syntax    | Query   | :CONFigure:STARTTime?                               |
|           | Response  | year<NR1>,month<NR1>,day<NR1>,hour<NR1>,minute<NR1> |
| Example   | :CONFigure:STARTTime?<br>(Response) :CONFIGURE:STARTTIME 24,1,2,12,34 (When the header is ON) |   |
| Parameter |   |   |
| year      | 21 to 37 (year)   |   |
| month     | 1 to 12 (month)   |   |
| day       | 1 to 31 (days)  |   |
| hour      | 0 to 23 (hours)   |   |
| minute    | 0 to 59 (minutes)   |   |

### When the repetitive recording is ON

After the data are recorded for the specified time, it takes time for the internal processing (dead time) before the next recording can be started. The data are not recorded during the dead time.

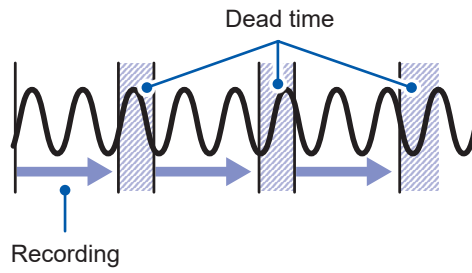

During normal sampling, the data can be recorded without any dead time by setting the recording time to continuous and enabling auto-save with file division. The data file to be saved can be divided at a specified time.



## Set the synchronized terminal

Multiple units of the instrument can be operated synchronously.

To perform the synchronized operation, follow the procedure in “Wiring the optical connection cable (LR8102 only)” (p. 53).

The sampling clocks of the multiple instruments can be synchronized (the multiple units record the data at the same timing).

When an external sampling is used, synchronous operation cannot be set.

### 1 Set the synchronized operation.

| Settings                      |  |                         |
|-------------------------------|--|-------------------------|
| Syntax                        | Command  | :CONFigure:SYNC:SET A\$ |
| Example                       | :CONFigure:SYNC:SET PRIMary  |                         |
| Query                         |  |                         |
| Syntax                        | Query  | :CONFigure:SYNC:SET?    |
|                               | Response   | A\$                     |
| Example                       | :CONFigure:SYNC:SET?<br>(Response) :CONFIGURE:SYNC:SET PRIMary (When the header is ON) |                         |
| Parameter                     |  |                         |
| A\$ = OFF, PRIMary, SECondary |  |                         |
| OFF <sup>☑</sup>              | Synchronized operation disabled  |                         |
| PRIMary                       | Primary  |                         |
| SECondary                     | Secondary  |                         |

The synchronized operation cannot be set during the measurement.

### 2 Check the wiring of the optical connection cables.

| Query   |  |                        |
|---|--|------------------------|
| Syntax  | Query  | :CONFigure:SYNC:CHECK? |
|   | Response   | A<NR1>                 |
| Example   | :CONFigure:SYNC:CHECK?<br>(Response) :CONFIGURE:SYNC:CHECK 1 (When the header is ON) |                        |
| Parameter   |  |                        |
| A\$ = 0 to 255  |  |                        |
| The result of the following wiring checks is returned with a numerical value in the NR1 format. For example, a returned value of 1 indicates that the instrument is not set to primary. |  |                        |
| Bit0  | The bit is set if the synchronized operation setting is not primary.                 |                        |
| Bit4  | The bit is set if the number of secondary units could be more than 9.                |                        |
| Bit7  | The bit is set if the optical connection cables could be disconnected.               |                        |
| Other bits are fixed to 0.  |  |                        |

#### IMPORTANT

- Use the primary unit to start and stop measurement. Measurement cannot be started or stopped from the secondary unit. Use the :ABORT command to stop measurement in the secondary unit.
- When using the start trigger, set the start trigger for all devices.
- If an error occurs in the synchronization signal during synchronized operation, the synchronized operation is automatically stopped.

## Data refresh interval of the measurement modules

The data refresh interval of each measurement module can be set separately from the recording interval of the instrument.

### Data refresh interval

The intervals at which a measurement module updates the measurement data

### Recording interval

The intervals at which the instrument acquires the data from a measurement module (p.82)

## 1 Set the data refresh interval.

The data refresh intervals are as follows according to the settings of the target module.

| Module type   | M7100         |               | M7102         |               |
|---|---------------|---------------|---------------|---------------|
|   | 1 to 8 CH     | 9 to 15 CH    | 1 to 15 CH    | 16 to 30 CH   |
| • Voltage measurement only  | 5 ms or more  | 10 ms or more | 10 ms or more | 20 ms or more |
| • Thermocouple measurement included<br>• Wire break detection OFF | 10 ms or more |               |               |               |
| • Thermocouple measurement included<br>• Wire break detection ON  | 20 ms or more |               | 20 ms or more | 50 ms or more |

Set the data refresh interval of the specified module with a numerical value (in seconds).  
If A = 0, the data refresh interval is automatically set.

| Settings  |  |                             |
|---|--|-----------------------------|
| Syntax  | Command  | :MODULE:DATARate module\$,A |
| Example   | :MODULE:DATARate MODULE1,1.0E+00   |                             |
| Query   |  |                             |
| Syntax  | Query  | :MODULE:DATARate? module\$  |
|   | Response   | A                           |
| Example   | :MODULE:DATARate? MODULE1<br>(Response) :MODULE:DATARATE MODULE1,1.0E+00 (When the header is ON) |                             |
| Parameter   |  |                             |
| module\$ = MODULE1 to MODULE10<br>A = 0 (auto), 5.0E-3 to 1.0E+1 (sec)  |  |                             |
| 0 (auto) <sup>□</sup> , 5 ms, 10 ms, 20 ms, 50 ms, 100 ms, 200 ms, 500 ms, 1 s, 2 s, 5 s, 10 s  |  |                             |
| Normally, select 0 (auto). If auto is selected, the shortest data refresh interval is set for each measurement module based on the recording interval.<br>When other than auto is selected: A value more than the recording interval can be set. If the recording interval is 10 s or more, the data refresh interval is fixed to 10 s.<br>The possible data refresh interval setting varies with the modules to be used as well as the wire break detection settings.<br>If a value not listed in the settings is specified and if there are rates higher than the specified value, the nearest rate is applied.<br>When an external sampling is used, 0 (auto) cannot be set. |  |                             |



- It is recommended to use a longer time when the data refresh interval is not set to auto. Using a longer interval lowers the cutoff frequency of the digital filter as well as removes low frequency noise.
- The noise at the power-supply frequency can be removed by setting the data refresh interval so that the filter functions at 50 Hz or 60 Hz.

## 2 Check the filter cutoff frequency.

The filter cutoff frequency depends on the data refresh interval setting.

Check the cutoff frequency displayed for each module.

The current value of the filter cutoff frequency of the specified module is returned with a numerical value.

| Query                                       |   |  |
|---|---|--|
| Syntax                                      | Query   | <code>:MODule:DFILter? module\$</code> |
|   | Response  | <code>module\$,A&lt;NR3&gt;</code>     |
| Example                                     | <code>:MODule:DFILter? MODULE1</code><br>(Response) <code>:MODULE:DFILTER MODULE1,+7.4E+02</code> (When the header is ON) |  |
| Parameter                                   |   |  |
| <code>module\$</code> = MODULE1 to MODULE10 |   |  |

## 3 Set the power-supply frequency filter.

Set the filter so that the effect of the digital filter is maximized.

It is recommended to set the value to the same frequency as the power-supply frequency of the region where the instrument is used (50 Hz or 60 Hz).

| Settings                       |   |                                 |
|--------------------------------|---|---------------------------------|
| Syntax                         | Command   | <code>:MODule:FILTer A\$</code> |
| Example                        | <code>:MODule:FILTer 50HZ</code>  |                                 |
| Query                          |   |                                 |
| Syntax                         | Query   | <code>:MODule:FILTer?</code>    |
|                                | Response  | <code>A\$</code>                |
| Example                        | <code>:MODule:FILTer?</code><br>(Response) <code>:MODULE:FILTER 50HZ</code> (When the header is ON) |                                 |
| Parameter                      |   |                                 |
| <code>A\$</code> = 50HZ, 60HZ  |   |                                 |
| <code>50HZ</code>              | Use the digital filter for the 50 Hz region.  |                                 |
| <code>60HZ</code> <sup>□</sup> | Use the digital filter for the 60 Hz region.  |                                 |

The following command allows you to obtain the module information at a specified position.

| Query  |  |                                       |
|--|--|---------------------------------------|
| Syntax   | Query  | <code>:MODule:IDN? module\$</code>    |
|  | Response   | <code>module\$,A\$,B\$,C\$,D\$</code> |
| Example  | <code>:MODule:IDN? MODULE1</code><br>(Response) <code>:MODULE:IDN MODULE1,M7100,10000000,V 100,V 100</code><br>(When the header is ON) |                                       |
| Parameter  |  |                                       |
| <code>module\$</code> = MODULE1 to MODULE10                                |  |                                       |
| <code>A\$</code> = Product model name                                      |  |                                       |
| <code>B\$</code> = Serial number   |  |                                       |
| <code>C\$</code> = Module version  |  |                                       |
| <code>D\$</code> = Module FPGA version                                     |  |                                       |
| If a position where no module exist is specified, the response is UNKNOWN. |  |                                       |

## Relationship of the data refresh interval and the recording interval

- The measurement module sends the data to the instrument at the data refresh intervals.
- The instrument receives the data from the measurement module at the recording intervals.
- If the recording interval of the instrument is long, the waveform peaks cannot be recorded even when the data refresh interval of the measurement module is short.

|   | Data refresh interval |                      | Recording interval |                      |
|---|-----------------------|----------------------|--------------------|----------------------|
|   | Short                 | Long                 | Short              | Long                 |
| Effect of power-supply frequency filter | Weak                  | Strong               | –                  | –                    |
| Amount of data                          | –                     | –                    | Larger             | Smaller              |
| Waveform peaks                          | Easy to capture*1     | Difficult to capture | Easy to capture*1  | Difficult to capture |

\*1. When the data refresh interval and the recording interval are short

- For the M7100 or M7102 modules, the longer the data refresh interval, the lower the cutoff frequency of the digital filter. As a result, the effect of noise removal is increased. For the cutoff frequency, see the section for the digital filter of the modules in “Specifications of Modules” (p. 304).
- If the data refresh interval of the module is longer than the recording interval, the first two data sets become continuous and a delay occurs.

## Setting example

| Purpose   | Data refresh interval   | Recording interval |
|---|---|--------------------|
| Record signals with fast variation (electrical signals, etc.) | Shorten   | Shorten            |
| Record signals with slow variation (temperature, etc.)        | Extend  | Extend             |
| Record fast and slow signals simultaneously                   | Shorten for modules measuring fast signals<br>Extend for modules measuring slow signals | Shorten            |

Since the data refresh interval can be set for each module, the following usage is possible.

- For module 1, in order to reduce influence of noise during temperature measurement using a thermocouple, set the data refresh interval to 2 s so that the power supply noise can be removed.
- For module 2, in order to record battery voltage fluctuation, set the data refresh interval to 10 ms.
- For module 3, in order to record variation in the control signals at the maximum speed, set the data refresh interval to 5 ms.
- Set the recording interval of the instrument to 5 ms, so that it matches the shortest data refresh interval.

The instrument records the data from modules 1 to 3 at intervals of 5 ms.

If the recording interval of the instrument is shorter than the data refresh interval of a module, a constant value is recorded as the data from the module.

Example: When the recording interval is 10 ms and the data refresh interval is 1 s, the same data are recorded 100 times.

For the identification names of modules, see (p. 116).

### Data refresh interval for pulses

The pulse data are updated at the data refresh intervals.

The data refresh interval for pulses is automatically set according to the input types.

| Input type     |                                | Data refresh interval |
|----------------|--------------------------------|-----------------------|
| Count          |                                | 5 ms                  |
| Rotation speed | r/s or r/min (smoothing: 1 s)  | 10 ms                 |
|                | r/min (smoothing: 2 s to 60 s) | 50 ms                 |

- Pulse counting is not affected by the data refresh interval.
- If the recording interval is shorter than the data refresh interval, the pulse data and the data from the measurement module are updated at different timings even when their data refresh intervals are the same.

## 3.4 Setting the Voltage/Temp Module

Set the input channel of the M7100 or M7102 Voltage/Temp Module for voltage measurement, temperature measurement, etc.

|                |  |
|----------------|--|
| <b>Channel</b> | ▶ Enable the measurement channel.                              |
| <b>Input</b>   | ▶ Set the measurement target type. Voltage, thermocouple, etc. |
| <b>Range</b>   | ▶ Set the magnitude of the input signal.                       |

Set the scaling and comments as needed.

### Voltage measurement

The setting method for measuring voltage is described here.

#### Setting method

- 1 Enable the measurement channel.

| Settings  |   |                                     |
|---|---|-------------------------------------|
| <b>Syntax</b>   | Command   | <code>:MODule:STORe ch\$,A\$</code> |
| <b>Example</b>  | <code>:MODule:STORe CH1_1,ON</code>   |                                     |
| Query   |   |                                     |
| <b>Syntax</b>   | Query   | <code>:MODule:STORe? ch\$</code>    |
|   | Response  | <code>ch\$,A\$</code>               |
| <b>Example</b>  | <code>:MODule:STORe? CH1_1</code><br>(Response) <code>:MODULE:STORE CH1_1,ON</code> (When the header is ON) |                                     |
| Parameter   |   |                                     |
| <code>ch\$</code> = CH1_1 to CH10_30, PLS1, LOG, ALARM, W1 to W30 |   |                                     |
| <code>A\$</code> = OFF, ON  |   |                                     |

## 2 Set the input type to voltage.

| Settings                                     |  |                         |
|--|--|-------------------------|
| Syntax                                       | Command  | :MODule:INMOde ch\$,A\$ |
| Example                                      | :MODule:INMOde CH1_1,VOLTAGE   |                         |
| Query  |  |                         |
| Syntax                                       | Query  | :MODule:INMOde? ch\$    |
|  | Response   | ch\$,A\$                |
| Example                                      | :MODule:INMOde? CH1_1<br>(Response) :MODULE:INMODE CH1_1,VOLTAGE (When the header is ON) |                         |
| Parameter                                    |  |                         |
| ch\$ = CH1_1 to CH10_30<br>A\$ = VOLTAGE, TC |  |                         |
| VOLTAGE <sup>□</sup>                         | Voltage  |                         |
| TC   | Thermocouples  |                         |

## 3 Set the measurement range according to the measurement target.

(For M7100 or M7102)

| Settings  |   |   |
|---|---|---|
| Syntax  | Command   | :MODule:RANGe ch\$,A                          |
| Example   | :MODule:RANGe CH1_1,1E-1  |   |
| Query   |   |   |
| Syntax  | Query   | :MODule:RANGe? ch\$                           |
|   | Response  | ch\$,A<NR3> (1 digit after the decimal point) |
| Example   | :MODule:RANGe? CH1_1<br>(Response) :MODULE:RANGE CH1_1,+1.0E-01 (When the header is ON) |   |
| Parameter   |   |   |
| ch\$ = CH1_1 to CH10_30<br>A = Vertical axis range  |   |   |
| 10 mV <sup>□</sup> , 20 mV, 100 mV, 200 mV, 1 V, 2 V, 6 V, 10 V, 20 V, 60 V, 100 V, 1-5 V   |   |   |
| If a value not listed in the settings is specified and if there is a range right above the value, the range is applied.<br>To set the voltage range to 1-5 V, set A = 15. |   |   |

### When measuring the output from an instrumentation device

- To measure a 4-20 mA current, connect a 250  $\Omega$  resistor between the plus and minus terminals of the input terminal.  
See "Wiring the voltage cable and thermocouple" (p. 44).
- When measuring the output from a 4-20 mA instrumentation device, the 1-5 V range is useful.



With the scaling function, the measured voltage value can be converted to a value in a specified unit.  
See "3.6 Using the Scaling Function" (p. 109).

## Temperature (thermocouple) measurement

The setting method for measuring temperature using a thermocouple is described here.

Applicable modules: M7100, M7102

### 1 Enable the measurement channel.

| Settings   |          |   |
|--|----------|---|
| Syntax   | Command  | :MODule:STORe ch\$,A\$  |
| Example  |          | :MODule:STORe CH1_1,ON  |
| Query  |          |   |
| Syntax   | Query    | :MODule:STORe? ch\$   |
|  | Response | ch\$,A\$  |
| Example  |          | :MODule:STORe? CH1_1<br>(Response) :MODULE:STORe CH1_1,ON (When the header is ON) |
| Parameter  |          |   |
| ch\$ = CH1_1 to CH10_30, PLS1, LOG, ALARM, W1 to W30 |          |   |
| A\$ = OFF, ON  |          |   |

### 2 Set the input type to thermocouple

| Settings                |               |   |
|-------------------------|---------------|---|
| Syntax                  | Command       | :MODule:INMOde ch\$,A\$   |
| Example                 |               | :MODule:INMOde CH1_1,TC   |
| Query                   |               |   |
| Syntax                  | Query         | :MODule:INMOde? ch\$  |
|                         | Response      | ch\$,A\$  |
| Example                 |               | :MODule:INMOde? CH1_1<br>(Response) :MODULE:INMODE CH1_1,TC (When the header is ON) |
| Parameter               |               |   |
| ch\$ = CH1_1 to CH10_30 |               |   |
| A\$ = VOLTAGE, TC       |               |   |
| VOLTAGE <sup>□</sup>    | Voltage       |   |
| TC                      | Thermocouples |   |



### 3 Set the measurement range according to the measurement temperature.

| Settings  |  |  |
|---|--|--|
| Syntax  | Command  | <code>:MODule:RANGe ch\$,A</code>                                |
| Example   | <code>:MODule:RANGe CH1_1,1E+2</code>  |  |
| Query   |  |  |
| Syntax  | Query  | <code>:MODule:RANGe? ch\$</code>                                 |
|   | Response   | <code>ch\$,A&lt;NR3&gt;</code> (1 digit after the decimal point) |
| Example   | <code>:MODule:RANGe? CH1_1</code><br>(Response) <code>:MODULE:RANGE CH1_1,1.0E+02</code> (When the header is ON) |  |
| Parameter   |  |  |
| <code>ch\$</code> = CH1_1 to CH10_30<br><code>A</code> = Vertical axis range  |  |  |
| <div style="border: 1px solid black; padding: 5px; background-color: #e0f2f1;"> <code>100°C</code> <input type="checkbox"/>, <code>500°C</code>, <code>2000°C</code> </div>   |  |  |
| Thermocouple B cannot be selected for the 100°C range and the 500°C range.<br>When using thermocouple B, set the range to the 2000°C range in advance.<br>If a value not listed in the settings is specified and if there is a range right above the value, the range is applied. |  |  |

### 4 Set the thermocouple type to be used.

| Settings   |  |                                      |
|--|--|--------------------------------------|
| Syntax   | Command  | <code>:MODule:SENSor ch\$,A\$</code> |
| Example  | <code>:MODule:SENSor CH1_1,K</code>  |                                      |
| Query  |  |                                      |
| Syntax   | Query  | <code>:MODule:SENSor? ch\$</code>    |
|  | Response   | <code>ch\$,A\$</code>                |
| Example  | <code>:MODule:SENSor? CH1_1</code><br>(Response) <code>:MODULE:SENSOR CH1_1,K</code> (When the header is ON) |                                      |
| Parameter  |  |                                      |
| <code>ch\$</code> = CH1_1 to CH10_30<br><code>A\$</code> = K, J, E, T, N, R, S, B, C   |  |                                      |
| <div style="border: 1px solid black; padding: 5px; background-color: #e0f2f1;"> <code>K</code> <input type="checkbox"/>, <code>J</code>, <code>E</code>, <code>T</code>, <code>N</code>, <code>R</code>, <code>S</code>, <code>B</code>*1, <code>C</code> </div> |  |                                      |
| *1. B can be selected for the 2000°C range.<br>See "Temperature measurement range" (p. 99).  |  |                                      |

## 5 Set the wire break detection.

| Settings  |  |                           |
|---|--|---------------------------|
| Syntax  | Command  | :MODule:WIRE module\$,A\$ |
| Example   | :MODule:WIRE MODULE1,ON  |                           |
| Query   |  |                           |
| Syntax  | Query  | :MODule:WIRE? module\$    |
|   | Response   | module\$,A\$              |
| Example   | :MODule:WIRE? MODULE1<br>(Response) :MODULE:WIRE MODULE1,ON (When the header is ON)  |                           |
| Parameter                                       |  |                           |
| module\$ = MODULE1 to MODULE10<br>A\$ = OFF, ON |  |                           |
| OFF <sup>☐</sup>                                | Thermocouple wire break detection is not performed.<br>When the thermocouple is disconnected, the value may fluctuate.   |                           |
| ON  | Thermocouple wire break detection is performed during the thermocouple temperature measurement.<br>The data during wire break are special values.<br>See "14.12 Data Handling" (p. 336).<br>There is a limit to the data refresh interval that can be set.<br>See "Thermocouple wire break detection" (p. 99). |                           |

## 6 Set the method of reference junction compensation.

| Settings                                  |   |                      |
|---|---|----------------------|
| Syntax                                    | Command   | :MODule:RJC ch\$,A\$ |
| Example                                   | :MODule:RJC CH1_1,INT   |                      |
| Query                                     |   |                      |
| Syntax                                    | Query   | :MODule:RJC? ch\$    |
|   | Response  | ch\$,A\$             |
| Example                                   | :MODule:RJC? CH1_1<br>(Response) :MODULE:RJC CH1_1,INT (When the header is ON)  |                      |
| Parameter                                 |   |                      |
| ch\$ = CH1_1 to CH10_30<br>A\$ = INT, EXT |   |                      |
| INT <sup>☐</sup>                          | The reference junction compensation is implemented inside the measurement module.<br>This setting is made when a thermocouple (or compensating lead wire) is connected directly to the instrument.<br>The measurement accuracy is the value obtained when the reference junction compensation accuracy are added to the temperature measurement accuracy. |                      |
| EXT                                       | The reference junction compensation is not implemented inside the measurement module.<br>This setting is made when a zero junction compensator (0°C ice water, etc.) is externally connected.<br>The measurement accuracy is specified only by the temperature measurement accuracy.  |                      |

## Temperature measurement range

The temperature measurement range depends on the thermocouple types.

| Thermocouples   | Temperature measurement range |
|-----------------|-------------------------------|
| K               | -200°C to 1350°C              |
| J               | -200°C to 1200°C              |
| E               | -200°C to 1000°C              |
| T               | -200°C to 400°C               |
| N               | -200°C to 1300°C              |
| R               | 0°C to 1700°C                 |
| S               | 0°C to 1700°C                 |
| B* <sup>1</sup> | 400°C to 1800°C               |
| C               | 0°C to 2000°C                 |

\*1. Can be selected for the 2000°C range. Temperature from 0°C to 400°C is recorded even if B is selected. However, the accuracy cannot be guaranteed.

## Thermocouple wire break detection

- During temperature measurement using a thermocouple, wire break detection is performed by inputting a fine current at the data refresh intervals.
- Since a wire break is detected at a different timing to measurement, the measurement values are not affected.
- If the data refresh intervals are the same, the cutoff frequency is higher when the wire break detection is set to ON compared with the case where the wire break detection is set to OFF. Therefore, the effect of noise removal is decreased.  
See “digital filter” of the modules in “13.2 Specifications of Modules” (p. 304) to check the cutoff frequency.
- A resistance value of the thermocouple that approximately exceeds the following value is considered a wire break.

| Thermocouples | Range      |            |             |
|---------------|------------|------------|-------------|
|               | 100°C f.s. | 500°C f.s. | 2000°C f.s. |
| K             | 3570 Ω     | 3430 Ω     | 8330 Ω      |
| J             | 3350 Ω     | 5010 Ω     | 5680 Ω      |
| E             | 3140 Ω     | 3280 Ω     | 4480 Ω      |
| T             | 3530 Ω     | 3460 Ω     | 3460 Ω      |
| N             | 510 Ω      | 4120 Ω     | 1570 Ω      |
| R             | 920 Ω      | 580 Ω      | 3550 Ω      |
| S             | 920 Ω      | 620 Ω      | 760 Ω       |
| B             | –          | –          | 1133 Ω      |
| C             | 770 Ω      | 390 Ω      | 1190 Ω      |

When using an extended thermocouple with the wire break detection set to ON, use a thermocouple with a large wire diameter to avoid false detection.

## 3.5 Configuring the Pulse Channel and Logic Channel Settings

### Pulse aggregation

The number of integrated pulses output from the integrated power meter or flow meter can be measured.

The setting method for performing aggregation measurement is described here.

External control terminal: Pulse input terminal (PULSE)

When an external sampling is used, the pulse channel cannot be used.

#### 1 Set the input type to Count.

The range is fixed to 1000 Mc.

| Settings  |  |  |
|---|--|--|
| Syntax  | Command  | <code>:MODule:PINMode pls\$,A\$</code> |
| Example   | <code>:MODule:PINMode PLS1,COUNT</code>  |  |
| Query   |  |  |
| Syntax  | Query  | <code>:MODule:PINMode? pls\$</code>    |
|   | Response   | <code>pls\$,A\$</code>                 |
| Example   | <code>:MODule:PINMode? PLS1</code><br>(Response) <code>:MODULE:PINMODE PLS1,COUNT</code> (When the header is ON) |  |
| Parameter   |  |  |
| <code>pls\$</code> = PLS1<br><code>A\$</code> = COUNT, REVOLVE, LOGIC |  |  |
| <code>COUNT</code>  | Aggregation  |  |
| <code>REVOLVE</code>  | Rotation speed   |  |
| <code>LOGIC</code>  | Logic  |  |

#### 2 Enable the measurement channel.

| Settings  |   |                                     |
|---|---|-------------------------------------|
| Syntax  | Command   | <code>:MODule:STORe ch\$,A\$</code> |
| Example   | <code>:MODule:STORe PLS1,ON</code>  |                                     |
| Query   |   |                                     |
| Syntax  | Query   | <code>:MODule:STORe? ch\$</code>    |
|   | Response  | <code>ch\$,A\$</code>               |
| Example   | <code>:MODule:STORe? PLS1</code><br>(Response) <code>:MODULE:STORE PLS1,ON</code> (When the header is ON) |                                     |
| Parameter   |   |                                     |
| <code>ch\$</code> = CH1_1 to CH10_30, PLS1, LOG, ALARM, W1 to W30<br><code>A\$</code> = OFF, ON |   |                                     |

### 3 Set the counting method.

| Settings                        |  |                           |
|---------------------------------|--|---------------------------|
| Syntax                          | Command  | :MODule:PCOMode pls\$,A\$ |
| Example                         | :MODule:PCOMode PLS1,ADD   |                           |
| Query                           |  |                           |
| Syntax                          | Query  | :MODule:PCOMode? pls\$    |
|                                 | Response   | pls\$,A\$                 |
| Example                         | :MODule:PCOMode? PLS1<br>(Response) :MODULE:PCOMODE PLS1,ADD (When the header is ON)   |                           |
| Parameter                       |  |                           |
| pls\$ = PLS1<br>A\$ = ADD, INST |  |                           |
| ADD <sup>☑</sup>                | Addition<br>Integrates the number of pulses input after the measurement is started.  |                           |
| INST                            | Instant value<br>Integrates the number of pulses input to the instrument within the recording interval. The number of pulses is reset for each recording interval. |                           |

### 4 Set the slope for counting.

| Settings                       |   |                          |
|--------------------------------|---|--------------------------|
| Syntax                         | Command   | :MODule:PSLOPe pls\$,A\$ |
| Example                        | :MODule:PSLOPe PLS1,UP  |                          |
| Query                          |   |                          |
| Syntax                         | Query   | :MODule:PSLOPe? pls\$    |
|                                | Response  | pls\$,A\$                |
| Example                        | :MODule:PSLOPe? PLS1<br>(Response) :MODULE:PSLOPE PLS1,UP (When the header is ON)   |                          |
| Parameter                      |   |                          |
| pls\$ = PLS1<br>A\$ = UP, DOWN |   |                          |
| UP <sup>☑</sup>                | Integrates the number of times the pulse changes from the Low to High level (rise). |                          |
| DOWN                           | Integrates the number of times the pulse changes from the High to Low level (fall). |                          |

### 5 Set the level for counting.

| Settings                     |   |                         |
|------------------------------|---|-------------------------|
| Syntax                       | Command   | :MODule:PTHRe pls\$,A\$ |
| Example                      | :MODule:PTHRe PLS1,1V   |                         |
| Query                        |   |                         |
| Syntax                       | Query   | :MODule:PTHRe? pls\$    |
|                              | Response  | pls\$,A\$               |
| Example                      | :MODule:PTHRe? PLS1<br>(Response) :MODULE:PTHRE PLS1,1V (When the header is ON)                       |                         |
| Parameter                    |   |                         |
| pls\$ = PLS1<br>A\$ = 1V, 4V |   |                         |
| 1V <sup>☑</sup>              | Determines 1.0 V or higher to be the High level, 0 or higher and less than 0.5 V to be the Low level. |                         |
| 4V                           | Determines 4.0 V or higher to be the High level, 0 or higher and less than 1.5 V to be the Low level. |                         |

## 6 Set whether or not to use the chattering prevention filter.

When this setting is ON, a count error due to chattering can be prevented for the mechanical contact (relay) output.

| Settings                      |   |                           |
|-------------------------------|---|---------------------------|
| Syntax                        | Command   | :MODule:PFILTer pls\$,A\$ |
| Example                       | :MODule:PFILTer PLS1,ON   |                           |
| Query                         |   |                           |
| Syntax                        | Query   | :MODule:PFILTer? pls\$    |
|                               | Response  | pls\$,A\$                 |
| Example                       | :MODule:PFILTer? PLS1<br>(Response) :MODULE:PFILTER PLS1,ON (When the header is ON) |                           |
| Parameter                     |   |                           |
| pls\$ = PLS1<br>A\$ = OFF, ON |   |                           |

## 7 Set the timing to reset the count.

| Settings                             |  |   |
|--------------------------------------|--|---|
| Syntax                               | Command  | :MODule:PCOSTart pls\$,A\$  |
| Example                              | :MODule:PCOSTart PLS1,START  |   |
| Query                                |  |   |
| Syntax                               | Query  | :MODule:PCOSTart? pls\$   |
|                                      | Response   | pls\$,A\$   |
| Example                              | :MODule:PCOSTart? PLS1<br>(Response) :MODULE:PCOSTART PLS1,START (When the header is ON) |   |
| Parameter                            |  |   |
| pls\$ = PLS1<br>A\$ = START, TRIGger |  |   |
| START <sup>□</sup>                   | Start  | Resets the count to 0 when the measurement is started.  |
| TRIGger                              | Trigger  | Resets the count to 0 when the measurement is started and when the trigger is activated. The value before being reset is recorded at the trigger point. |

## 8 Set the operation to be performed when the integrated value overflows.

| Settings                      |   |                          |
|-------------------------------|---|--------------------------|
| Syntax                        | Command   | :MODule:PRESet pls\$,A\$ |
| Example                       | :MODule:PRESet PLS1,ON  |                          |
| Query                         |   |                          |
| Syntax                        | Query   | :MODule:PRESet? pls\$    |
|                               | Response  | pls\$,A\$                |
| Example                       | :MODule:PRESet? PLS1<br>(Response) :MODULE:PRESET PLS1,ON (When the header is ON) |                          |
| Parameter                     |   |                          |
| pls\$ = PLS1<br>A\$ = OFF, ON |   |                          |
| OFF <sup>□</sup>              | Stops counting.   |                          |
| ON                            | Resets the count value and restarts counting from 0.                              |                          |



- With the scaling function, the number of integrated pulses can be recorded as a value that is converted to a physical quantity (Wh, VA, etc.) for the measurement target. See “3.6 Using the Scaling Function” (p. 109).
- Up to 1,000,000,000 pulses can be measured. If there is a possibility that the number of pulses may exceed this value, it is recommended to perform measurement with the count mode set to the instant value and integrate the pulses later using Excel and the like.

## Rotation speed measurement

The number of pulses output according to the rotation speed of the rotary encoder or speed recorder can be measured.

The number of pulses per second is counted to calculate the rotation speed.

External control terminal: Pulse input terminal (PULSE)

When an external sampling is used, the pulse channel cannot be used.

### 1 Set the input type to rotation speed.

| Settings                                 |  |  |
|--|--|--|
| <b>Syntax</b>                            | Command  | <code>:MODule:PINMode pls\$,A\$</code> |
| <b>Example</b>                           | <code>:MODule:PINMode PLS1,REVOLVE</code>  |  |
| Query                                    |  |  |
| <b>Syntax</b>                            | Query  | <code>:MODule:PINMode? pls\$</code>    |
|  | Response   | <code>pls\$,A\$</code>                 |
| <b>Example</b>                           | <code>:MODule:PINMode? PLS1</code><br>(Response) <code>:MODULE:PINMODE PLS1,REVOLVE</code> (When the header is ON) |  |
| Parameter                                |  |  |
| <code>pls\$</code> = PLS1                |  |  |
| <code>A\$</code> = COUNT, REVOLVE, LOGIC |  |  |
| <code>COUNT</code> <sup>□</sup>          | Aggregation  |  |
| <code>REVOLVE</code>                     | Rotation speed   |  |
| <code>LOGIC</code>                       | Logic  |  |

### 2 Enable the measurement channel.

| Settings  |   |                                     |
|---|---|-------------------------------------|
| <b>Syntax</b>   | Command   | <code>:MODule:STORe ch\$,A\$</code> |
| <b>Example</b>  | <code>:MODule:STORe PLS1,ON</code>  |                                     |
| Query   |   |                                     |
| <b>Syntax</b>   | Query   | <code>:MODule:STORe? ch\$</code>    |
|   | Response  | <code>ch\$,A\$</code>               |
| <b>Example</b>  | <code>:MODule:STORe? PLS1</code><br>(Response) <code>:MODULE:STORE PLS1,ON</code> (When the header is ON) |                                     |
| Parameter   |   |                                     |
| <code>ch\$</code> = CH1_1 to CH10_30, PLS1, LOG, ALARM, W1 to W30 |   |                                     |
| <code>A\$</code> = OFF, ON  |   |                                     |

### 3 Set the reference time for counting.

| Settings  |   |                          |
|---|---|--------------------------|
| Syntax  | Command   | :MODule:PRANGe pls\$,A\$ |
| Example   | :MODule:PRANGe PLS1,RPM   |                          |
| Query   |   |                          |
| Syntax  | Query   | :MODule:PRANGe? pls\$    |
|   | Response  | pls\$,A\$                |
| Example   | :MODule:PRANGe? PLS1<br>(Response) :MODULE:PRANGe PLS1,RPM (When the header is ON)  |                          |
| Parameter   |   |                          |
| pls\$ = PLS1<br>A\$ = RPS, RPM  |   |                          |
| RPS <sup>☐</sup>  | r/s (number of rotations per second)<br>The number of pulses per second is counted to calculate the rotation speed.                               |                          |
| RPM   | r/min (number of rotations per minute)<br>The number of pulses for a specified smoothing time is counted to calculate the rotation speed. (p.105) |                          |
| A command error occurs if the pulse input type (p. 103) is not set to the rotation speed. |   |                          |

### 4 Set the number of pulses per rotation output from the encoder or tachometer.

| Settings                        |  |                        |
|---------------------------------|--|------------------------|
| Syntax                          | Command  | :MODule:PCOUnt pls\$,A |
| Example                         | :MODule:PCOUnt PLS1,1  |                        |
| Query                           |  |                        |
| Syntax                          | Query  | :MODule:PCOUnt? pls\$  |
|                                 | Response   | pls\$,A<NR1>           |
| Example                         | :MODule:PCOUnt? PLS1<br>(Response) :MODULE:PCOUNT PLS1,1 (When the header is ON) |                        |
| Parameter                       |  |                        |
| pls\$ = PLS1<br>A\$ = 1 to 1000 |  |                        |

### 5 Set the slope for counting.

| Settings                       |   |                          |
|--------------------------------|---|--------------------------|
| Syntax                         | Command   | :MODule:PSLOPe pls\$,A\$ |
| Example                        | :MODule:PSLOPe PLS1,UP  |                          |
| Query                          |   |                          |
| Syntax                         | Query   | :MODule:PSLOPe? pls\$    |
|                                | Response  | pls\$,A\$                |
| Example                        | :MODule:PSLOPe? PLS1<br>(Response) :MODULE:PSLOPE PLS1,UP (When the header is ON)   |                          |
| Parameter                      |   |                          |
| pls\$ = PLS1<br>A\$ = UP, DOWN |   |                          |
| UP <sup>☐</sup>                | Integrates the number of times the pulse changes from the Low to High level (rise). |                          |
| DOWN                           | Integrates the number of times the pulse changes from the High to Low level (fall). |                          |



## 6 Set the level for counting.

| Settings                     |   |                         |
|------------------------------|---|-------------------------|
| Syntax                       | Command   | :MODule:PTHRe pls\$,A\$ |
| Example                      | :MODule:PTHRe PLS1,1V   |                         |
| Query                        |   |                         |
| Syntax                       | Query   | :MODule:PTHRe? pls\$    |
|                              | Response  | pls\$,A\$               |
| Example                      | :MODule:PTHRe? PLS1<br>(Response) :MODULE:PTHRE PLS1,1V (When the header is ON)                       |                         |
| Parameter                    |   |                         |
| pls\$ = PLS1<br>A\$ = 1V, 4V |   |                         |
| 1V <sup>☑</sup>              | Determines 1.0 V or higher to be the High level, 0 or higher and less than 0.5 V to be the Low level. |                         |
| 4V                           | Determines 4.0 V or higher to be the High level, 0 or higher and less than 1.5 V to be the Low level. |                         |

## 7 Set whether or not to use the chattering prevention filter.

When this setting is ON, a count error due to chattering can be prevented for the mechanical contact (relay) output.

| Settings                      |   |                           |
|-------------------------------|---|---------------------------|
| Syntax                        | Command   | :MODule:PFILTer pls\$,A\$ |
| Example                       | :MODule:PFILTer PLS1,ON   |                           |
| Query                         |   |                           |
| Syntax                        | Query   | :MODule:PFILTer? pls\$    |
|                               | Response  | pls\$,A\$                 |
| Example                       | :MODule:PFILTer? PLS1<br>(Response) :MODULE:PFILTER PLS1,ON (When the header is ON) |                           |
| Parameter                     |   |                           |
| pls\$ = PLS1<br>A\$ = OFF, ON |   |                           |

## 8 Set the processing period for smoothing. {When the reference time for counting is in RPM (r/min)} (p. 104)

| Settings                            |  |                         |
|-------------------------------------|--|-------------------------|
| Syntax                              | Command  | :MODule:PSMooth pls\$,A |
| Example                             | :MODule:PSMooth PLS1,1   |                         |
| Query                               |  |                         |
| Syntax                              | Query  | :MODule:PSMooth? pls\$  |
|                                     | Response   | pls\$,A<NR1>            |
| Example                             | :MODule:PSMooth? PLS1<br>(Response) :MODULE:PSMOOTH PLS1,1 (When the header is ON) |                         |
| Parameter                           |  |                         |
| pls\$ = PLS1<br>A\$ = 1 (OFF) to 60 |  |                         |
| 1 s <sup>☑</sup> to 60 s            |  |                         |
| Smoothing is turned OFF when A = 1. |  |                         |

## Principle of rotation speed measurement

In the following cases, the number of integrated pulses is internally updated at the data refresh intervals of 10 ms.

- When the range is RPS (r/s)
- When the range is RPM (r/min) and the smoothing is set to 1 s

Rotation speed  $r$  at time  $t$  [s] is calculated by dividing the number of pulses between  $(t - 1)$  and  $t$  [s] by the number of pulses per rotation.

$$r \text{ (r/s)} = \frac{\text{Number of integrated pulses of } t \text{ [s]} - \text{number of integrated pulses of } (t - 1) \text{ [s]}}{\text{Number of pulses per rotation}}$$

r/s: Number of rotations per second

$$r \text{ (r/min)} = \frac{\text{Number of integrated pulses of } t \text{ [s]} - \text{number of integrated pulses of } (t - 1) \text{ [s]}}{\text{Number of pulses per rotation}} \times 60$$

r/min: Rotation speed per 60 s (when the smoothing is set to **[1 s]**)

Example: When the number of pulses per rotation = 4,  
the number of integrated pulses at 1 s (P1) = 1000 c,  
and the number of integrated pulses at 2 s (P2) = 2000 c,  
the rotation speed at  $t = 2$  s ( $r_{t=2}$ ) is calculated as follows.  
 $r_{t=2} = (2000 - 1000) / 4 = 250$  r/s

When the range is RPM (r/min) and the smoothing is set to  $t_0$  [s], the number of integrated pulses is internally updated at the data refresh intervals of 50 ms.

Rotation speed  $r$  at time  $t$  [s] is calculated by dividing the number of pulses between  $(t - t_0)$  and  $t$  [s] by the number of pulses per rotation and the smoothing time and then multiplying the quotient by 60.

$$r \text{ (r/min)} = \frac{\text{Number of integrated pulses of } t \text{ [s]} - \text{number of integrated pulses of } (t - t_0) \text{ [s]}}{\text{Number of pulses per rotation}} \times \frac{60}{t_0}$$

### When the range is RPM (r/min)

When time  $t$  [s] satisfies  $t < t_0$  ( $t_0$ : The time set for smoothing), the value of the recorded rotation speed is smaller than the actual rotation speed due to smoothing (only when  $t_0 \geq 2$  s).

If an unintended trigger is activated, set the smoothing time to 1 s.

#### Example with $t_0 = 5$ s

The recorded value of rotation speed is increased for  $t_0$  [s] after the measurement is started.

Even if a constant rotation speed is input, the recorded value appears to be increased since the start of measurement until  $t_0$  [s] due to the smoothing process.

## Logic signal measurement

The signals can be measured as logic data of 0 and 1.  
When an external sampling is used, the logic channel cannot be used.

### 1 Set the measurement type to logic.

| Settings  |  |  |
|---|--|--|
| <b>Syntax</b>   | Command  | <code>:MODule:PINMOde pls\$,A\$</code> |
| <b>Example</b>  | <code>:MODule:PINMOde PLS1,LOGIC</code>  |  |
| Query   |  |  |
| <b>Syntax</b>   | Query  | <code>:MODule:PINMOde? pls\$</code>    |
|   | Response   | <code>pls\$,A\$</code>                 |
| <b>Example</b>  | <code>:MODule:PINMOde? PLS1</code><br>(Response) <code>:MODULE:PINMODE PLS1,LOGIC</code> (When the header is ON) |  |
| Parameter   |  |  |
| <code>pls\$</code> = PLS1<br><code>A\$</code> = COUNT, REVOLVE, LOGIC |  |  |
| <code>COUNT</code> <sup>□</sup>                                       | Aggregation  |  |
| <code>REVOLVE</code>  | Rotation speed   |  |
| <code>LOGIC</code>  | Logic  |  |

### 2 Enable the measurement channel.

Enable the pulse measurement channel.

| Settings  |   |                                     |
|---|---|-------------------------------------|
| <b>Syntax</b>   | Command   | <code>:MODule:STORe ch\$,A\$</code> |
| <b>Example</b>  | <code>:MODule:STORe LOG,ON</code>   |                                     |
| Query   |   |                                     |
| <b>Syntax</b>   | Query   | <code>:MODule:STORe? ch\$</code>    |
|   | Response  | <code>ch\$,A\$</code>               |
| <b>Example</b>  | <code>:MODule:STORe? LOG</code><br>(Response) <code>:MODULE:STORE LOG,ON</code> (When the header is ON) |                                     |
| Parameter   |   |                                     |
| <code>ch\$</code> = CH1_1 to CH10_30, PLS1, LOG, ALARM, W1 to W30<br><code>A\$</code> = OFF, ON |   |                                     |

### 3 Set the level for counting.

| Settings                     |   |                         |
|------------------------------|---|-------------------------|
| Syntax                       | Command   | :MODULE:PTHRe pls\$,A\$ |
| Example                      | :MODULE:PTHRe PLS1,1V   |                         |
| Query                        |   |                         |
| Syntax                       | Query   | :MODULE:PTHRe? pls\$    |
|                              | Response  | pls\$,A\$               |
| Example                      | :MODULE:PTHRe? PLS1<br>(Response) :MODULE:PTHRE PLS1,1V (When the header is ON)                       |                         |
| Parameter                    |   |                         |
| pls\$ = PLS1<br>A\$ = 1V, 4V |   |                         |
| 1V <sup>☑</sup>              | Determines 1.0 V or higher to be the High level, 0 or higher and less than 0.5 V to be the Low level. |                         |
| 4V                           | Determines 4.0 V or higher to be the High level, 0 or higher and less than 1.5 V to be the Low level. |                         |

### 4 Set whether or not to use the chattering prevention filter.

When this setting is ON, a count error due to chattering can be prevented for the mechanical contact (relay) output.

| Settings                      |   |                           |
|-------------------------------|---|---------------------------|
| Syntax                        | Command   | :MODULE:PFILTer pls\$,A\$ |
| Example                       | :MODULE:PFILTer PLS1,ON   |                           |
| Query                         |   |                           |
| Syntax                        | Query   | :MODULE:PFILTer? pls\$    |
|                               | Response  | pls\$,A\$                 |
| Example                       | :MODULE:PFILTer? PLS1<br>(Response) :MODULE:PFILTER PLS1,ON (When the header is ON) |                           |
| Parameter                     |   |                           |
| pls\$ = PLS1<br>A\$ = OFF, ON |   |                           |

## 3.6 Using the Scaling Function

By using the scaling function, the voltage value measured with the instrument can be converted and recorded as a physical quantity (current, temperature, etc.) for the measurement target. Using Logger Utility, the converted value can be displayed with a decimal fraction or exponential notation.

Example: Slope = 50,  
Unit = A

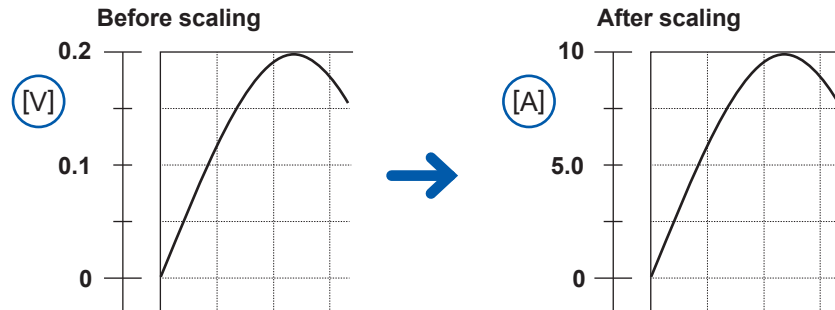

### 1 Set the display method for scaling.

| Settings                                   |  |  |
|--|--|--|
| <b>Syntax</b>                              | Command  | <code>:SCALing:SET ch\$,A\$</code>   |
| <b>Example</b>                             |  | <code>:SCALing:SET CH1_1,ENG</code>  |
| Query                                      |  |  |
| <b>Syntax</b>                              | Query  | <code>:SCALing:SET? ch\$</code>  |
|  | Response   | <code>ch\$,A\$</code>  |
| <b>Example</b>                             |  | <code>:SCALing:SET? CH1_1</code><br>(Response) <code>:SCALING:SET CH1_1,ENG</code> (When the header is ON) |
| Parameter                                  |  |  |
| <code>ch\$</code> = CH1_1 to CH10_30, PLS1 |  |  |
| <code>A\$</code> = OFF, ENG, SCI           |  |  |
| <b>OFF</b> <sup>□</sup>                    | Disables the scaling function.   |  |
| <b>ENG</b>                                 | Enables the scaling function. When Logger Utility is used, a value is displayed with a decimal fraction.   |  |
| <b>SCI</b>                                 | Enables the scaling function. When Logger Utility is used, a value is displayed with exponential notation. |  |

### 2 Set the conversion method for scaling.

| Settings                                   |  |  |
|--|--|--|
| <b>Syntax</b>                              | Command                                | <code>:SCALing:KIND ch\$,A\$</code>  |
| <b>Example</b>                             |  | <code>:SCALing:KIND CH1_1,POINT</code>   |
| Query                                      |  |  |
| <b>Syntax</b>                              | Query                                  | <code>:SCALing:KIND? ch\$</code>   |
|  | Response                               | <code>ch\$,A\$</code>  |
| <b>Example</b>                             |  | <code>:SCALing:KIND? CH1_1</code><br>(Response) <code>:SCALING:KIND CH1_1,POINT</code> (When the header is ON) |
| Parameter                                  |  |  |
| <code>ch\$</code> = CH1_1 to CH10_30, PLS1 |  |  |
| <code>A\$</code> = RATIO, POINT, SENS      |  |  |
| <b>RATIO</b> <sup>□</sup>                  | Uses the conversion ratio for scaling. |  |
| <b>POINT</b>                               | Specifies two points for scaling.      |  |
| <b>SENS</b>                                | Uses the sensitivity for scaling.      |  |

See “Scaling setting for integrated measurement.” (p. 113).

### 3 Set the unit after conversion.

See "(3) Character string data" (p. 24).

| Settings   |          |   |
|--|----------|---|
| Syntax   | Command  | <code>:SCALing:UNIT ch\$,"A\$"</code>   |
| Example  |          | <code>:SCALing:UNIT CH1_1,"mA"</code>   |
| Query  |          |   |
| Syntax   | Query    | <code>:SCALing:UNIT? ch\$</code>  |
|  | Response | <code>ch\$,"A\$"</code>   |
| Example  |          | <code>:SCALing:UNIT? CH1_1</code><br>(Response) <code>:SCALING:UNIT CH1_1,"mA"</code> (When the header is ON) |
| Parameter  |          |   |
| <code>ch\$</code> = CH1_1 to CH10_30, PLS1   |          |   |
| <code>A\$</code> = Character string of unit (up to 3 double-byte characters or 7 single-byte characters) |          |   |

### 4 (When the conversion method for scaling is set to the conversion ratio method)

Set the slope (scaling conversion value).

| Settings   |          |  |
|--|----------|--|
| Syntax   | Command  | <code>:SCALing:VOLT ch\$,A</code>  |
| Example  |          | <code>:SCALing:VOLT CH1_1,1</code>   |
| Query  |          |  |
| Syntax   | Query    | <code>:SCALing:VOLT? ch\$</code>   |
|  | Response | <code>ch\$,A&lt;NR3&gt;</code> (4 digits after the decimal point)  |
| Example  |          | <code>:SCALing:VOLT? CH1_1</code><br>(Response) <code>:SCALING:VOLT CH1_1,+1.0000E+00</code> (When the header is ON) |
| Parameter  |          |  |
| <code>ch\$</code> = CH1_1 to CH10_30, PLS1   |          |  |
| <code>A</code> = -9.9999E+09 to +9.9999E+09*1 (+1.0000E-09 to +9.9999E+09 for pulse integration) |          |  |
| *1. 0 cannot be set.   |          |  |

Set the offset.

| Settings                                   |          |  |
|--|----------|--|
| Syntax                                     | Command  | <code>:SCALing:OFFSet ch\$,A</code>  |
| Example                                    |          | <code>:SCALing:OFFSet CH1_1,0</code>   |
| Querying the scaling offset                |          |  |
| Syntax                                     | Query    | <code>:SCALing:OFFSet? ch\$</code>   |
|  | Response | <code>ch\$,A&lt;NR3&gt;</code> (4 digits after the decimal point)  |
| Example                                    |          | <code>:SCALing:OFFSet? CH1_1</code><br>(Response) <code>:SCALING:OFFSET CH1_1,+0.0000E+00</code> (When the header is ON) |
| Parameter                                  |          |  |
| <code>ch\$</code> = CH1_1 to CH10_30, PLS1 |          |  |
| <code>A</code> = -9.9999E+09 to 9.9999E+09 |          |  |

#### Setting example

Measurement is performed using a differential probe with division ratio of 1/100. The waveform data are recorded as a value represented in the voltage unit (V).

|        |     |
|--------|-----|
| Unit   | V   |
| Slope  | 100 |
| Offset | 0   |

## 5 (When the conversion method for scaling is set to the two-point method)

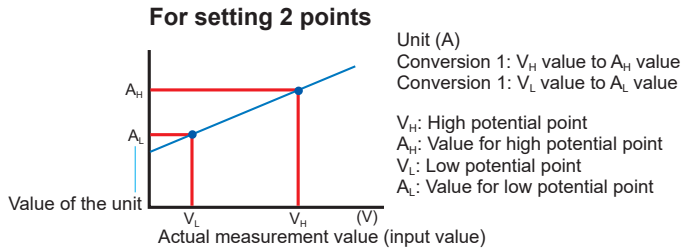

Set the high point and low point of the unit to be converted.

| Settings  |          |   |
|---|----------|---|
| Syntax  | Command  | <code>:SCALing:VOUPLow ch\$,A,B</code>  |
| Example   |          | <code>:SCALing:VOUPLow CH1_1,0.05,-0.05</code>  |
| Query   |          |   |
| Syntax  | Query    | <code>:SCALing:VOUPLow? ch\$</code>   |
|   | Response | <code>ch\$,A&lt;NR3&gt;,B&lt;NR3&gt;</code> (4 digits after the decimal point)  |
| Example   |          | <code>:SCALing:VOUPLow? CH1_1</code><br>(Response) <code>:SCALING:VOUPLow CH1_1,+5.0000E-02,-5.0000E-02</code><br>(When the header is ON) |
| Parameter   |          |   |
| <code>ch\$</code> = CH1_1 to CH10_30, PLS1<br><code>A,B</code> = -9.9999E+29 to +9.9999E+29<br>A = B cannot be set. |          |   |

Set the high point and low point of the actual measured value.

| Settings  |          |   |
|---|----------|---|
| Syntax  | Command  | <code>:SCALing:SCUPLow ch\$,A,B</code>  |
| Example   |          | <code>:SCALing:SCUPLow CH1_1,0.5,-0.5</code>  |
| Query   |          |   |
| Syntax  | Query    | <code>:SCALing:SCUPLow? ch\$</code>   |
|   | Response | <code>ch\$,A&lt;NR3&gt;,B&lt;NR3&gt;</code> (4 digits after the decimal point)  |
| Example   |          | <code>:SCALing:SCUPLow? CH1_1</code><br>(Response) <code>:SCALING:SCUPLow CH1_1,+5.0000E-01,-5.0000E-01</code><br>(When the header is ON) |
| Parameter   |          |   |
| <code>ch\$</code> = CH1_1 to CH10_30, PLS1<br><code>A,B</code> = -9.9999E+29 to +9.9999E+29<br>A = B cannot be set. |          |   |

### Setting example

Convert a 4-20 mA output from the sensor to a value between 0 mm and 100 mm.  
 The 4-20 mA output is measured between 1 V and 5 V using a 250  $\Omega$  shunt resistor.  
 The range from 1 V to 5 V is converted to the range from 0 mm to 100 mm.

|      |  |
|------|--|
| Unit | mm   |
| A    | $1^{*1} \rightarrow 0^{*2}$ (1 V $\rightarrow$ 0 mm)     |
| B    | $5^{*1} \rightarrow 100^{*2}$ (5 V $\rightarrow$ 100 mm) |

\*1. Set with `SCALing:VOUPLow`

\*2. Set with `SCALing:SCUPLow`

## 6 (When the conversion method for scaling is set to the sensitivity method)

Set the sensitivity.

| Settings                       |  |   |
|--------------------------------|--|---|
| Syntax                         | Command  | :SCALing:SENSE ch\$,A                         |
| Example                        | :SCALing:SENSE CH1_1,1   |   |
| Query                          |  |   |
| Syntax                         | Query  | :SCALing:SENSE? ch\$                          |
|                                | Response   | ch\$,A<NR3> (4 digit after the decimal point) |
| Example                        | :SCALing:SENSE? CH1_1<br>(Response) :SCALING:SENSE CH1_1,+1.0000E+00 (When the header is ON) |   |
| Parameter                      |  |   |
| ch\$ = CH1_1 to CH10_30, PLS1  |  |   |
| A = -1.0000E+09 to +1.0000E+09 |  |   |
| *1.0 cannot be set.            |  |   |

### Setting example

Measurement is performed using a heat flow sensor with sensitivity constant of  $0.02421 \text{ mV/W}\cdot\text{m}^2$ . The waveform data are recorded represented in the unit of  $\text{W/m}^2$ .

|             |                |
|-------------|----------------|
| Unit        | $\text{W/m}^2$ |
| Sensitivity | 0.02421 m      |
| Offset      | 0              |



#### Checking the waveform before the scaling conversion

If the waveform data are saved in the binary format, the waveform before the scaling conversion and the scaling settings are recorded.



## Scaling setting for integrated measurement.

With the scaling function, the number of integrated pulses can be recorded as a value that is converted to a physical quantity (Wh, VA, etc.) for the measurement target.

For a pulse output instrument, the physical quantity per pulse or the number of pulses per basic unit (example: 1 kWh, 1 L, 1 m<sup>3</sup>) is defined.

### 1 Set the display method for scaling.

| Settings   |  |                                    |
|--|--|------------------------------------|
| Syntax   | Command  | <code>:SCALing:SET ch\$,A\$</code> |
| Example  | <code>:SCALing:SET PLS1,ENG</code>   |                                    |
| Query  |  |                                    |
| Syntax   | Query  | <code>:SCALing:SET? ch\$</code>    |
|  | Response   | <code>ch\$,A\$</code>              |
| Example  | <code>:SCALing:SET? PLS1</code><br>(Response) <code>:SCALING:SET PLS1,ENG</code> (When the header is ON) |                                    |
| Parameter  |  |                                    |
| <code>ch\$</code> = CH1_1 to CH10_30, PLS1           |  |                                    |
| <code>A\$</code> = OFF, ENG, SCI                     |  |                                    |
| <code>OFF</code> <input checked="" type="checkbox"/> | Disables the scaling function.   |                                    |
| <code>ENG</code>                                     | Enables the scaling function. Displays a value with a decimal fraction.                                  |                                    |
| <code>SCI</code>                                     | Enables the scaling function. Displays a value with exponential notation.                                |                                    |

### 2 Set the unit after change.

See "(3) Character string data" (p. 24).

| Settings   |  |                                       |
|--|--|---------------------------------------|
| Syntax   | Command  | <code>:SCALing:UNIT ch\$,"A\$"</code> |
| Example  | <code>:SCALing:UNIT PLS1,"kWh"</code>  |                                       |
| Query  |  |                                       |
| Syntax   | Query  | <code>:SCALing:UNIT? ch\$</code>      |
|  | Response   | <code>ch\$,"A\$"</code>               |
| Example  | <code>:SCALing:UNIT? PLS1</code><br>(Response) <code>:SCALING:UNIT PLS1,"kWh"</code> (When the header is ON) |                                       |
| Parameter  |  |                                       |
| <code>ch\$</code> = CH1_1 to CH10_30, PLS1   |  |                                       |
| <code>A\$</code> = Character string of unit (up to 3 double-byte characters or 7 single-byte characters) |  |                                       |

### 3 Set the physical quantity per pulse.

When you set the number of pulses per standard unit (example: 1 c = 1 pulse), set the reciprocal of the physical quantity per pulse for "A" .

| Settings   |  |  |
|--|--|--|
| Syntax   | Command  | <code>:SCALing:VOLT ch\$,A</code>                                |
| Example  | <code>:SCALing:VOLT PLS1,1</code>  |  |
| Query  |  |  |
| Syntax   | Query  | <code>:SCALing:VOLT? ch\$</code>                                 |
|  | Response   | <code>ch\$,A&lt;NR3&gt;</code> (4 digit after the decimal point) |
| Example  | <code>:SCALing:VOLT? PLS1</code><br>(Response) <code>:SCALING:VOLT PLS1,+1.0000E+00</code> (When the header is ON) |  |
| Parameter  |  |  |
| <code>ch\$</code> = CH1_1 to CH10_30, PLS1<br><code>A</code> = -9.9999E+09 to +9.9999E+09 (+1.0000E-09 to +9.9999E+09 for pulse integration) |  |  |

#### Setting example

When integrating the number of pulses with a 50,000 pulse/kWh power meter connected

```
:SCALing:SET PLS1,ENG
:SCALing:UNIT PLS1,"kWh"
:SCALing:VOLT PLS1,+5.0E+4
```

When integrating the number of pulses with a 10 L/pulse flow meter connected

```
:SCALing:SET PLS1,ENG
:SCALing:UNIT PLS1,"L"
:SCALing:VOLT PLS1,+1.0E-1
```

# 3.7 Entering Comments

You can enter a title for measurement, comment for each channel, and identification name for the module.

## Title comment

You can enter any character string as a title for measurement.  
See "(3) Character string data" (p. 24).

| Settings   |  |                      |
|--|--|----------------------|
| Syntax   | Command  | :COMMeNt:TITLe "A\$" |
| Example  | :COMMeNt:TITLe "HIOKI"   |                      |
| Query  |  |                      |
| Syntax   | Query  | :COMMeNt:TITLe?      |
|  | Response   | "A\$"                |
| Example  | :COMMeNt:TITLe?<br>(Response) :COMMENT:TITLe "HIOKI" (When the header is ON) |                      |
| Parameter  |  |                      |
| A\$ = Character string of comment (up to 20 double-byte characters or 40 single-byte characters) |  |                      |

## Channel comment

You can enter any character string for each channel.  
See "(3) Character string data" (p. 24).

| Settings   |   |                         |
|--|---|-------------------------|
| Syntax   | Command   | :COMMeNt:CH ch\$, "A\$" |
| Example  | :COMMeNt:CH CH1_1, "ABCDEFG"  |                         |
| Query  |   |                         |
| Syntax   | Query   | :COMMeNt:CH? ch\$       |
|  | Response  | ch\$, "A\$"             |
| Example  | :COMMeNt:CH? CH1_1<br>(Response) :COMMENT:CH CH1_1, "ABCDEFG" (When the header is ON) |                         |
| Parameter  |   |                         |
| ch\$ = CH1_1 to CH10_30, PLS1, W1 to W30   |   |                         |
| A\$ = Character string of comment (up to 20 double-byte characters or 40 single-byte characters) |   |                         |

## Module identification name

You can enter an identification name (any character string) for each module.  
 Use these names to identify modules when multiple modules are used.  
 See "(3) Character string data" (p. 24).

| Settings  |          |   |
|---|----------|---|
| Syntax  | Command  | :COMMeNt:MODUle module\$, "A\$"   |
| Example   |          | :COMMeNt:MODUle MODULE1, "ABCDEFG"  |
| Query   |          |   |
| Syntax  | Query    | :COMMeNt:MODUle? module\$   |
|   | Response | module\$, "A\$"   |
| Example   |          | :COMMeNt:MODUle? MODULE1<br>(Response) :COMMeNt:MODUle MODULE1, "ABCDEFG" (When the header is ON) |
| Parameter   |          |   |
| module\$ = MODULE1 to MODULE10<br>A\$ = Character string of comment (up to 8 double-byte characters or 16 single-byte characters) |          |   |

# 3.8 Performing Zero Adjustment

Deviation in the input part is corrected so that the reference potential of the instrument becomes 0 V.

Perform zero adjustment when there is no input. Zero adjustment may not be performed correctly if there is any input. It is not necessary to short circuit between the positive terminal and negative terminal of the measuring instrument.

|                       |  |                              |
|-----------------------|--|------------------------------|
| <b>Query</b>          |  |                              |
| <b>Syntax</b>         | Query  | <code>:MODule:ADJUST?</code> |
|                       | Response   | <code>A&lt;NR1&gt;</code>    |
| <b>Example</b>        | <code>:MODule:ADJUST?</code><br>(Response) <code>:MODULE:ADJUST 1</code> (When the header is ON) |                              |
| <b>Parameter</b>      |  |                              |
| <code>A = 1, 0</code> |  |                              |
| <code>0</code>        | Success  |                              |
| <code>1</code>        | Failure  |                              |

When the beep sound is enabled, a beep sound is issued once in the case of a success, or it is issued twice in the case of a failure. See "Beep sound" (p. 227).

## 3.9 Starting and Stopping Measurement

Use the following command to start measurement.

| Settings       |                |                |
|----------------|----------------|----------------|
| <b>Syntax</b>  | Command        | : <b>START</b> |
| <b>Example</b> | : <b>START</b> |                |

Use the following command to stop measurement.

| Settings       |   |               |
|----------------|---|---------------|
| <b>Syntax</b>  | Command   | : <b>STOP</b> |
| <b>Example</b> | : <b>STOP</b>   |               |
| <b>NOTICE</b>  | <p>The operation depends on the recording time setting.</p> <p>First :<b>STOP</b> command</p> <p>When the recording time is set to continuous recording: The measurement is not stopped.</p> <p>When the recording time is set to time specification: The measurement is performed for the specified recording time and then stopped.</p> <p>Second :<b>STOP</b> command</p> <p>When the recording time is set to continuous recording: The measurement is stopped.</p> <p>When the recording time is set to time specification: The measurement is stopped. (The timing when processing the :<b>STOP</b> command is completed is the timing when the measurement is actually stopped.)</p> |               |

If the measurement is stopped and then started again, the measurement data in the internal buffer memory of the instrument is deleted. Save important data in an SD memory card or USB drive before starting the measurement again.



- Measurement can be automatically stopped at the specified time. See “3.3 Setting Measurement Conditions” (p. 82).
- The recording operation can be started under specific conditions. This function is useful for monitoring errors. See “5 Trigger Function” (p. 137).

### Measurement operation

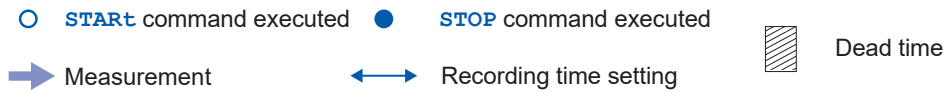

| Recording time  | Repetitive recording: OFF | Repetitive recording: ON            |
|---|---------------------------|-------------------------------------|
| Time specification<br>( <b>STOP</b> command is not executed)                    |                           |                                     |
| Time specification<br>( <b>STOP</b> command is executed during the measurement) |                           |                                     |
| Continuous recording  |                           | (Same as Repetitive recording: OFF) |



**When a power failure has occurred during the measurement**

- Measurement cannot be performed during a power failure.
- Measurement data before the power failure cannot be retained. However, if the auto-save operation is enabled, the data before the power failure is saved in the medium (SD memory card or USB drive). See "Preparations and settings in case of power failure" (p. 161).
- The measurement is not restarted even if the power is restored. However, if the start status hold function (start backup) is enabled, the recording is restarted when the power is restored.

### Forcing termination of measurement

- The measurement is stopped even if the waveform capture operation is not completed.
- It is not possible to wait for the completion of measurement using a command in combination with **\*OPC**, etc.  
Example of inoperable command: **:ABORT ; \*OPC?**
- If the instrument is set to a secondary unit of the synchronized operation, the measurement cannot be stopped.

| Settings |               |               |
|----------|---------------|---------------|
| Syntax   | Command       | <b>:ABORT</b> |
| Example  | <b>:ABORT</b> |               |

## Handling of data exceeding the allowable measurement range

Regardless of the measurement target, the measured value exceeding the allowable measurement range is handled as an overrange value. The values listed in “14.12 Data Handling” (p. 336) are saved for the data and calculation result.

## Measurement operation status change

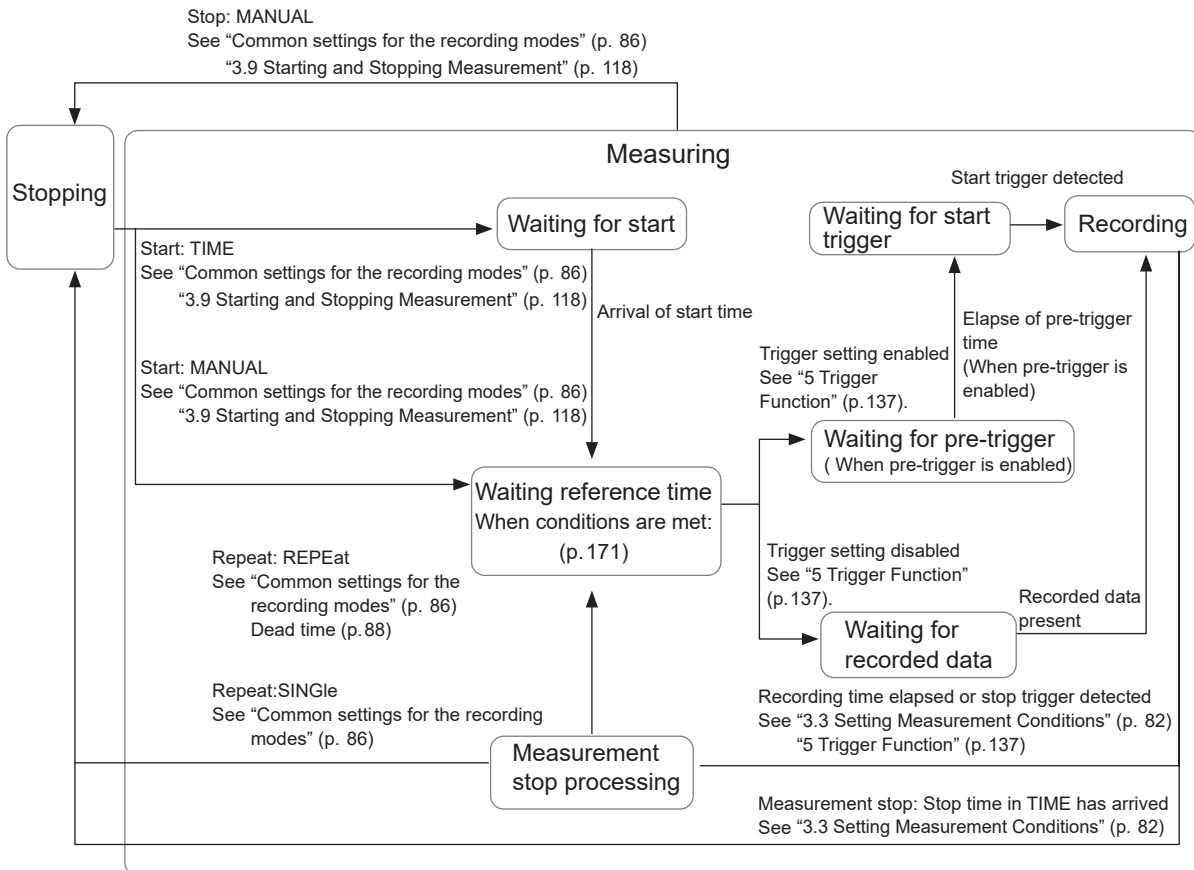



## 3.10 Checking Measurement Start Time and Trigger Time

### 1 Query the start trigger detection date.

When the start trigger is set to OFF, the measurement start date is returned.

| Query  |   |  |
|--|---|--|
| Syntax   | Query   | <code>:TRIGger:DETECTDate?</code>                            |
|  | Response  | <code>year&lt;NR1&gt;,month&lt;NR1&gt;,day&lt;NR1&gt;</code> |
| Example  | <code>:TRIGger:DETECTDate?</code><br>(Response) <code>:TRIGGER:DETECTDATE 19,12,26</code> (When the header is ON) |  |
| Parameter  |   |  |
| If there is no storage data, "00,00,00" is returned. |   |  |
| <code>year</code>                                    | 00 to 37 (year)   |  |
| <code>month</code>                                   | 01 to 12 (month)  |  |
| <code>day</code>                                     | 01 to 31 (days)   |  |

### 2 Query the start trigger detection time.

When the start trigger is set to OFF, the measurement start time is returned.

| Query  |   |  |
|--|---|--|
| Syntax   | Query   | <code>:TRIGger:DETECTTime?</code>  |
|  | Response  | <code>hour&lt;NR1&gt;,min&lt;NR1&gt;,sec&lt;NR1&gt;,ms&lt;NR1&gt;</code> |
| Example  | <code>:TRIGger:DETECTTime?</code><br>(Response) <code>:TRIGGER:DETECTTIME 01,02,03,004</code> (When the header is ON) |  |
| Parameter  |   |  |
| If there is no storage data, "00,00,00,000" is returned. |   |  |
| <code>hour</code>  | 00 to 23 (hours)  |  |
| <code>min</code>   | 00 to 59 (minutes)  |  |
| <code>sec</code>   | 00 to 59 (seconds)  |  |
| <code>ms</code>  | 000 to 999 (millisecond)  |  |



**IMPORTANT**

Realtime acquisition of measurement data is limited during the measurement.  
See “4.7 Comparison of Realtime Data Acquisition” (p. 136).

**Before acquiring measurement data**

- Complete the settings required for measurement. (p.81)
- Confirm that the measurement on the target channel of acquisition is enabled, if needed.

| Query  |   |  |
|--|---|--|
| Syntax   | Query   | <code>:MEMory:TARCH? module\$</code><br><code>:MEMory:TVRCH? module\$</code> |
|  | Response  | <code>ch1\$,ch2\$,...</code>   |
| Example  | <code>:MEMory:TARCH? MODULE1</code><br>(Response) <code>:MEMORY:TARCH CH1_1,CH1_2,CH1_3,CH1_4,CH1_5</code><br>(When the header is ON) |  |
| Parameter  |   |  |
| <code>module\$</code> = MODULE1 to MODULE10, PLS&ALM, CALC1, CALC2 |   |  |
| <code>ch\$</code> = CH1_1 to CH10_30, PLS1, LOG, ALARM, W1 to W30  |   |  |

**List of data acquisition commands**

By sending the following commands, the measurement results can be acquired in response.

| Data acquired             | Target    | Command* <sup>1</sup>  |                        |                       | Reference  |
|---------------------------|-----------|------------------------|------------------------|-----------------------|--|
|                           |           | Acquired in text       |                        | Acquired in binary    |  |
|                           |           | Physical quantity      | AD value               |                       |  |
| Time series multiple data | 1 channel | <code>:VDATA?</code>   | <code>:ADATA?</code>   | <code>:BDATA?</code>  | “4.1 Acquiring Measurement Data on Internal Memory” (p. 124) |
| Latest data               | 1 channel | <code>:VREAL?</code>   | <code>:AREAL?</code>   | <code>:BREAL?</code>  | “4.2 Acquiring Realtime Data” (p. 127)                       |
|                           | 1 module  | <code>:TVREAL?</code>  | <code>:TAREAL?</code>  | –                     |  |
| Hold data                 | 1 channel | <code>:VFETCh?</code>  | <code>:AFETCh?</code>  | <code>:BFETCh?</code> | “4.3 Acquiring Hold Data” (p. 129)                           |
|                           | 1 module  | <code>:TVFETCh?</code> | <code>:TAFETCh?</code> | –                     |  |

\*1.The command requires `:MEMory` at the beginning. (Example: `:MEMory:VDATA?`)

When acquiring text, it becomes more difficult to acquire all data in real time as the instrument configuration is scaled up.

The waveform data of the instrument can be acquired with various methods other than text. Select an appropriate method according to the application.

See “Comparison of Realtime Data Acquisition” (p. 136).

## 4.1 Acquiring Measurement Data on Internal Memory

### 1 Start measurement.

When the measurement has been stopped, the measurement data on the internal memory can be acquired in the same way.

| Settings |         |        |
|----------|---------|--------|
| Syntax   | Command | :START |
| Example  | :START  |        |

### 2 Check the number of measurement data.

Confirm that the number of measurement data units is 1 or more and acquire the data.

| Query  |  |   |
|--|--|---|
| Syntax   | Query  | :MEMory:AMAXPoint? (Number saved on the internal memory after measurement)<br>:MEMory:MAXPoint? (Number saved on the internal memory) |
|  | Response   | A<NR1>  |
| Example  | :MEMory:AMAXPoint?<br>(Response) :MEMORY:AMAXPOINT 800 (When the header is ON) |   |
| Parameter                                      |  |   |
| A = Number of measurement data (0 = not saved) |  |   |

### 3 Confirm that the measurement data on the target channel exists.

Confirm that the measurement on the target channel exists, if needed.

Check the measurement data of the target channel.

| Query   |   |                       |
|---|---|-----------------------|
| Syntax  | Query   | :MEMory:CHStore? ch\$ |
|   | Response  | ch\$,A\$              |
| Example   | :MEMory:CHStore? CH1_1<br>(Response) :MEMORY:CHSTORE CH1_1,ON (When the header is ON) |                       |
| Parameter   |   |                       |
| ch\$ = CH1_1 to CH10_30, PLS1, LOG, ALARM, W1 to W30<br>A\$ = OFF, ON |   |                       |

Check the measurement data of the target module.

| Query   |   |  |
|---|---|--|
| Syntax  | Query   | :MEMory:TCHStore? module\$   |
|   | Response  | ch1\$,ch2\$, ...<br>If the specified module is not installed, the response is <b>MODULE_NONE</b> .<br>If the measurement of all channels in the specified module is set to OFF, the response is <b>NO DATA</b> . |
| Example   | :MEMory:TCHStore? MODULE1<br>(Response) :MEMORY:TCHSTORE CH1_1,CH1_2,CH1_3,CH1_4,CH1_5<br>(When the header is ON) |  |
| Parameter   |   |  |
| module\$ = MODULE1 to MODULE10, PLS&ALM, CALC1, CALC2<br>ch\$ = CH1_1 to CH10_30, PLS1, LOG, ALARM, W1 to W30 |   |  |

#### 4 Check the leading data number on the internal memory.

The data located within the internal memory can be acquired.

If needed, acquire the leading data number on the internal memory to check the data range.

| Query  |   |                                |
|--|---|--------------------------------|
| Syntax   | Query   | <code>:MEMory:TOPPoint?</code> |
|  | Response  | <code>A&lt;NR1&gt;</code>      |
| Example  | <code>:MEMory:TOPPoint?</code><br>(Response) <code>:MEMORY:TOPPOINT 10</code> (When the header is ON) |                                |
| Parameter  |   |                                |
| <code>A</code> = Leading data number (0 = not saved) |   |                                |

#### 5 Set the channel for acquisition and the output position.

Specify a position within the number of measurement data from the leading number on the internal memory.

| Settings   |  |   |
|--|--|---|
| Syntax   | Command  | <code>:MEMory:APOINT ch\$,A</code><br>The data number beyond the internal memory can be specified.<br><code>:MEMory:POINT ch\$,A</code><br>The data number beyond the internal memory cannot be specified.* 1 |
|  | Example  | <code>:MEMory:APOINT CH1_1,100</code>   |
| Query  |  |   |
| Syntax   | Query  | <code>:MEMory:APOINT?</code><br><code>:MEMory:POINT?</code>   |
|  | Response   | <code>ch\$,A&lt;NR1&gt;</code>  |
| Example  | <code>:MEMory:APOINT?</code><br>(Response) <code>:MEMORY:APOINT CH1_1,100</code> (When the header is ON) |   |
| Parameter  |  |   |
| <code>ch\$</code> = CH1_1 to CH10_30, PLS1, LOG, ALARM, W1 to W30<br><code>A</code> = 0 to (Number of data in storage - 1) |  |   |

\*1. If the measurement data with continuous recording could go beyond the internal memory, use `APOINT`. See "3.3 Setting Measurement Conditions" (p. 82).

#### 6 Acquire the measurement data.

A specified number of data points are acquired starting from the data specified with the channel for acquisition and the output position.

In addition, the output position is increased by the number of data points. (p. 126)

**When acquiring in text (physical value)**

| Query  |  |                                   |
|--|--|-----------------------------------|
| Syntax   | Query  | <code>:MEMory:VData? A</code>     |
|  | Response   | <code>B1,B2,...&lt;NR3&gt;</code> |
| Example  | <code>:MEMory:VData? 2</code><br>(Response) <code>:MEMORY:VDATA +5.000000E-03,+4.000000E-03</code> (When the header is ON) |                                   |
| Parameter  |  |                                   |
| <code>A</code> = 1 to 1000<br><code>Bi</code> = Measured value<br><br>Measured value of each channel<br>See "4.6 Text (Physical Value)" (p. 135) |  |                                   |

**When acquiring in text (AD value)**

| Query  |   |  |
|--|---|--|
| Syntax   | Query   | :MEMory:ADATa? A   |
|  | Response  | B1, B2, ...<NR1> (<NR3> for waveform calculation results only) |
| Example  | :MEMory:ADATa? 5<br>(Response) :MEMORY:ADATA 3176, 3176, 3176, 3186, 3186 (When the header is ON) |  |
| Parameter  |   |  |
| A = 1 to 2000 (Number of outputs)<br>Bi = -2147483648 to 2147483647 (Analog)<br>Bi = 0 to 2147483647 (aggregation, rotations)<br>Bi = 0 to 1 (Logic)<br>Bi = 0 to 15 (Alarm)<br>Bi = Waveform calculation result (Wave calc) |   |  |
| Method for converting the AD value to a physical value<br>See "4.4 Conversion of Measurement Data" (p. 133).   |   |  |

**When acquiring in binary**

| Query   |  |                               |
|---|--|-------------------------------|
| Syntax  | Query  | :MEMory:BDATa? A              |
|   | Response   | #0<The following binary data> |
| Example   | :MEMory:BDATa? 10<br>(Response) :MEMORY:BDATA #0...<Binary data> (When the header is ON) |                               |
| Parameter   |  |                               |
| A = 1 to 5000 (Number of outputs)<br>#0 (representing the binary format) is attached to the beginning of the output data.<br>Following #0, the storage data are sent in the binary format for the number of data points specified with A. |  |                               |
| Method for converting the AD value to a physical value<br>See "4.5 About Binary Data" (p. 134).   |  |                               |

**(Tips) Movement of the acquisition position**  
 The acquisition position is increased when the measurement data are acquired. Therefore, a value without data is acquired at a position where no data exists.

**Example:**

|                            |       |
|----------------------------|-------|
| Channel                    | CH1_2 |
| Recording interval         | 1 (s) |
| Recording length           | 2 (s) |
| Number of measurement data | 3     |

✓: Data present

1. Immediately after execution of :MEMory:POINT CH1\_2,0

|                           |   |   |   |   |
|---------------------------|---|---|---|---|
| Storage number            | 0 | 1 | 2 | 3 |
| Data present or absent    | ✓ | ✓ | ✓ | - |
| Data acquisition position | ↑ |   |   |   |

↓

2. Immediately after execution of :MEMory:VDATa?2

|                           |   |   |   |   |
|---------------------------|---|---|---|---|
| Storage number            | 0 | 1 | 2 | 3 |
| Data present or absent    | ✓ | ✓ | ✓ | - |
| Data acquisition position |   |   | ↑ |   |

↓

3. Immediately after execution of :MEMory:ADATa?2

|                           |   |   |   |   |
|---------------------------|---|---|---|---|
| Storage number            | 0 | 1 | 2 | 3 |
| Data present or absent    | ✓ | ✓ | ✓ | - |
| Data acquisition position |   |   |   | ↑ |

If first MEMory:ADATa?2 and then :MEMory:VDATa?2 are executed, the same result is obtained.

The data acquisition position is set to storage number 0 of CH1\_2.

The data in storage numbers 0 and 1 of CH1\_2 are output. The data acquisition position is moved to storage number 2.

The data in storage numbers 2 and 3 of CH1\_2 are output. The data in storage number 3 is null.  
  
 The data acquisition position is moved to storage number 3.

## 4.2 Acquiring Realtime Data

### 1 Acquire the relevant data.

The realtime data for each data unit can be acquired. Regardless of whether or not this command is used, while the instrument is performing the measurement, the latest data acquired in the measurement are used as the realtime data.

| Settings |                 |                 |
|----------|-----------------|-----------------|
| Syntax   | Command         | :MEMory:GETReal |
| Example  | :MEMory:GETReal |                 |

### 2 Acquire the measurement data.

#### Acquire data from each channel.

- When acquiring in text (physical value)

| Query  |  |                     |
|--|--|---------------------|
| Syntax   | Query  | :MEMory:VREAL? ch\$ |
|  | Response   | A<NR3>              |
| Example  | :MEMory:VREAL? CH1_1<br>(Response) :MEMORY:VREAL +1.230000E-03 (When the header is ON) |                     |
| Parameter  |  |                     |
| ch\$ = CH1_1 to CH10_30, PLS1, LOG, ALARM, W1 to W30<br>A = measured value<br><br>Measured value of each channel<br>See "4.6 Text (Physical Value)" (p. 135) |  |                     |

- When acquiring in text (AD value)

| Query  |   |   |
|--|---|---|
| Syntax   | Query   | :MEMory:AREAL? ch\$   |
|  | Response  | A<NR1> (<NR3> for waveform calculation results only)<br>If the specified target does not exist, NO_STORAGE is returned. |
| Example  | :MEMory:AREAL? CH1_1<br>(Response) :MEMORY:AREAL 3176 (When the header is ON) |   |
| Parameter  |   |   |
| ch\$ = CH1_1 to CH10_30, PLS1, LOG, ALARM, W1 to W30<br>A = -2147483648 to 2147483647 (Analog)<br>A = 0 to 2147483647 (aggregation, rotations)<br>A = 0 to 1 (Logic)<br>A = 0 to 15 (Alarm)<br>A = Waveform calculation result (Wave calc)<br><br>Method for converting the AD value to a physical value<br>See "4.4 Conversion of Measurement Data" (p. 133). |   |   |

- When acquiring in binary

| Query  |  |                     |
|--|--|---------------------|
| Syntax   | Query  | :MEMory:BreAL? ch\$ |
|  | Response   | A                   |
| Example  | :MEMory:BreAL? CH1_1<br>(Response) :MEMORY:BreAL (When the header is ON) |                     |
| Parameter  |  |                     |
| ch\$ = CH1_1 to CH10_30, PLS1, LOG, ALARM, W1 to W30<br>A = Binary data<br>See "4.5 About Binary Data" (p. 134). |  |                     |

**Acquire data from each module.**

Data can be acquired from the channel for which the measurement is set to ON in the target module.

- When acquiring in text (physical value)

| Query  |   |   |
|--|---|---|
| Syntax   | Query   | :MEMory:TVREAL? module\$  |
|  | Response  | A1,A2,...<NR3><br>If the specified target does not exist, NO_STORAGE is returned. |
| Example  | :MEMory:TVREAL? MODULE1<br>(Response) :MEMORY:TVREAL +1.000000E-03,+2.000000E-03,+3.000000E-03<br>(When the header is ON) |   |
| Parameter  |   |   |
| module\$ = MODULE1 to MODULE10, PLS&ALM, CALC1, CALC2<br>Ax = measured value<br><br>Measured value of each channel<br>See "4.6 Text (Physical Value)" (p. 135) |   |   |

- When acquiring in text (AD value)

| Query   |   |   |
|---|---|---|
| Syntax  | Query   | :MEMory:TAREAL? module\$  |
|   | Response  | A1,A2,...<NR1> (<NR3>) for waveform calculation results only<br>If the specified target does not exist, NO_STORAGE is returned. |
| Example   | :MEMory:TAREAL? MODULE1<br>(Response) :MEMORY:TAREAL 3176,3176,3176 (When the header is ON) |   |
| Parameter   |   |   |
| module\$ = MODULE1 to MODULE10, PLS&ALM, CALC1, CALC2<br>A = -2147483648 to 2147483647 (Analog)<br>A = 0 to 2147483647 (aggregation, rotations)<br>A = 0 to 1 (Logic)<br>A = 0 to 15 (Alarm)<br>A = Waveform calculation result (Wave calc)<br><br>Method for converting the AD value to a physical value<br>See "4.4 Conversion of Measurement Data" (p. 133). |   |   |



## 4.3 Acquiring Hold Data

### 1 Acquire the relevant data.

The hold data for each data unit can be acquired. While the instrument is performing the measurement, the latest data at the timing when the command is received is acquired as the hold data.

| Settings |                 |                 |
|----------|-----------------|-----------------|
| Syntax   | Command         | :MEMory:GETReal |
| Example  | :MEMory:GETReal |                 |

As it takes time to load data, be sure to proceed to the next step only after it has been confirmed that the data have been completely loaded using a command such as \*OPC? and \*WAI. While measurement is underway, new data can also be loaded when the measurement data are updated.

See “Acquire data at the timing when the measurement data are refreshed.” (p. 132)

### 2 Confirm that the hold data exists in the target channel.

Confirm that the data exists in the target channel, if needed.

This confirmation is not necessary if it has been already confirmed before starting the hold that the measurement channel is ON.

**Check the hold data in the target channel.**

| Query  |   |                        |
|--|---|------------------------|
| Syntax   | Query   | :MEMory:FCHStore? ch\$ |
|  | Response  | ch\$,A\$               |
| Example  | :MEMory:FCHStore? CH1_1<br>(Response) :MEMORY:FCHSTORE CH1_1,ON (When the header is ON) |                        |
| Parameter  |   |                        |
| ch\$ = CH1_1 to CH10_30, PLS1, LOG, ALARM, W1 to W30 |   |                        |
| A\$ = OFF, ON  |   |                        |

**Check the hold data in the target module.**

| Query   |   |  |
|---|---|--|
| Syntax  | Query   | :MEMory:TFCHStore? module\$  |
|   | Response  | ch1\$,ch2\$,...<br>If the specified module is not installed, the response is <b>MODULE_NONE</b> . If the measurement of all channels in the specified module is set to OFF, the response is <b>NO DATA</b> . |
| Example   | :MEMory:TFCHStore? MODULE1<br>(Response) :MEMORY:TFCHSTORE CH1_1,CH1_2,CH1_3,CH1_4,CH1_5<br>(When the header is ON) |  |
| Parameter   |   |  |
| module\$ = MODULE1 to MODULE10, PLS&ALM, CALC1, CALC2 |   |  |
| ch\$ = CH1_1 to CH10_30, PLS1, LOG, ALARM, W1 to W30  |   |  |

### 3 Acquire the measurement data.

#### Acquire data from each channel.

- When acquiring in text (physical value)

| Query  |  |                      |
|--|--|----------------------|
| Syntax   | Query  | :MEMory:VFETch? ch\$ |
|  | Response   | A<NR3>               |
| Example  | :MEMory:VFETch? CH1_1<br>(Response) :MEMORY:VFETCH +1.230000E-03 (When the header is ON) |                      |
| Parameter  |  |                      |
| ch\$ = CH1_1 to CH10_30, PLS1, LOG, ALARM, W1 to W30<br>A = measured value<br><br>Measured value of each channel<br>See "4.6 Text (Physical Value)" (p. 135) |  |                      |

- When acquiring in text (AD value)

| Query  |   |  |
|--|---|--|
| Syntax   | Query   | :MEMory:AFETch? ch\$                                 |
|  | Response  | A<NR1> (<NR3> for waveform calculation results only) |
| Example  | :MEMory:AFETch? CH1_1<br>(Response) :MEMORY:AFETCH 3176 (When the header is ON) |  |
| Parameter  |   |  |
| ch\$ = CH1_1 to CH10_30, PLS1, LOG, ALARM, W1 to W30<br>A = -2147483648 to 2147483647 (Analog)<br>A = 0 to 2147483647 (aggregation, rotations)<br>A = 0 to 1 (Logic)<br>A = 0 to 15 (Alarm)<br>A = Waveform calculation result (Wave calc)<br><br>Method for converting the AD value to a physical value<br>See "4.4 Conversion of Measurement Data" (p. 133). |   |  |

- When acquiring in binary

| Query   |  |                      |
|---|--|----------------------|
| Syntax  | Query  | :MEMory:BFETch? ch\$ |
|   | Response   | A                    |
| Example   | :MEMory:BFETch? CH1_1<br>(Response) :MEMORY:BFETCH (Binary data) (When the header is ON) |                      |
| Parameter   |  |                      |
| ch\$ = CH1_1 to CH10_30, PLS1, LOG, ALARM, W1 to W30<br>A = Binary data<br><br>• About binary data<br>See "4.5 About Binary Data" (p. 134).<br>• Method for converting the AD value to a physical value<br>See "4.4 Conversion of Measurement Data" (p. 133). |  |                      |

**Acquire data from each module.**

Data can be acquired from the channel for which the measurement is set to ON in the target module.

- When acquiring in text (physical value)

| Query  |   |  |
|--|---|--|
| Syntax   | Query   | <code>:MEMory:TVFETch? module\$</code> |
|  | Response  | <code>A1,A2,...&lt;NR3&gt;</code>      |
| Example  | <code>:MEMory:TVFETch? MODULE1</code><br>(Response) <code>:MEMORY:TVFETCH +1.000000E-03,+2.000000E-03,+3.000000E-03</code><br>(When the header is ON) |  |
| Parameter  |   |  |
| <code>module\$</code> = MODULE1 to MODULE10, PLS&ALM, CALC1, CALC2<br><code>Ax</code> = measured value<br><br>Measured value of each channel<br>See "4.6 Text (Physical Value)" (p. 135) |   |  |

- When acquiring in text (AD value)

| Query   |   |   |
|---|---|---|
| Syntax  | Query   | <code>:MEMory:TAFETch? module\$</code>  |
|   | Response  | <code>A1,A2,...&lt;NR1&gt; (&lt;NR3&gt;)</code> for waveform calculation results only |
| Example   | <code>:MEMory:TAFETch? MODULE1</code><br>(Response) <code>:MEMORY:TAFETCH 3176,3176,3176</code> (When the header is ON) |   |
| Parameter   |   |   |
| <code>module\$</code> = MODULE1 to MODULE10, PLS&ALM, CALC1, CALC2<br><code>A</code> = -2147483648 to 2147483647 (Analog)<br><code>A</code> = 0 to 2147483647 (aggregation, rotations)<br><code>A</code> = 0 to 1 (Logic)<br><code>A</code> = 0 to 15 (Alarm)<br><code>A</code> = Waveform calculation result (Wave calc)<br><br>Method for converting the AD value to a physical value<br>See "4.4 Conversion of Measurement Data" (p. 133). |   |   |

**Tips** **Acquire data at the timing when the measurement data are refreshed.**  
 By combining the acquisition of the hold data and the issuing of the following command, the data can be acquired at the timing when the measurement data are refreshed during the measurement. This method is useful for acquiring data at a high speed without dropping it.

Wait for the measurement data to be refreshed.

It is not necessary to use `:MEMory:GETReal`, as all measurement channels are loaded and retained as hold data.

| Query   |  |       |                             |          |                           |
|---|--|-------|-----------------------------|----------|---------------------------|
| <b>Syntax</b>   | <table border="1"> <tr> <td>Query</td> <td><code>:WAITNextsmpl?</code></td> </tr> <tr> <td>Response</td> <td><code>A&lt;NR1&gt;</code></td> </tr> </table>   | Query | <code>:WAITNextsmpl?</code> | Response | <code>A&lt;NR1&gt;</code> |
| Query   | <code>:WAITNextsmpl?</code>  |       |                             |          |                           |
| Response  | <code>A&lt;NR1&gt;</code>  |       |                             |          |                           |
| <b>Example</b>  | <pre> :WAITNextsmpl? (Response) :WAITNEXTSMPL 1000 (When the header is ON) :MEMory:TVFETch? MODULE1 (Response) :MEMORY:TVFETCH +1.000000E-03,+2.000000E-03,           +3.000000E-03 (When the header is ON)                     </pre> |       |                             |          |                           |
| Parameter   |  |       |                             |          |                           |
| <p><b>A</b> = 0 to (Latest storage number)<br/> <b>A</b> = -1 (While no measurement is being performed)<br/>                     If the recording interval is long (10 s or longer), this parameter cannot be used.</p> |  |       |                             |          |                           |

Possible command combinations to acquire the hold data

- `:MEMory:VFETch?`
- `:MEMory:AFETch?`
- `:MEMory:BFETch?`
- `:MEMory:TVFETch?`
- `:MEMory:TAFETch?`

**Hold data acquisition using the `:WAITNextsmpl?` command**

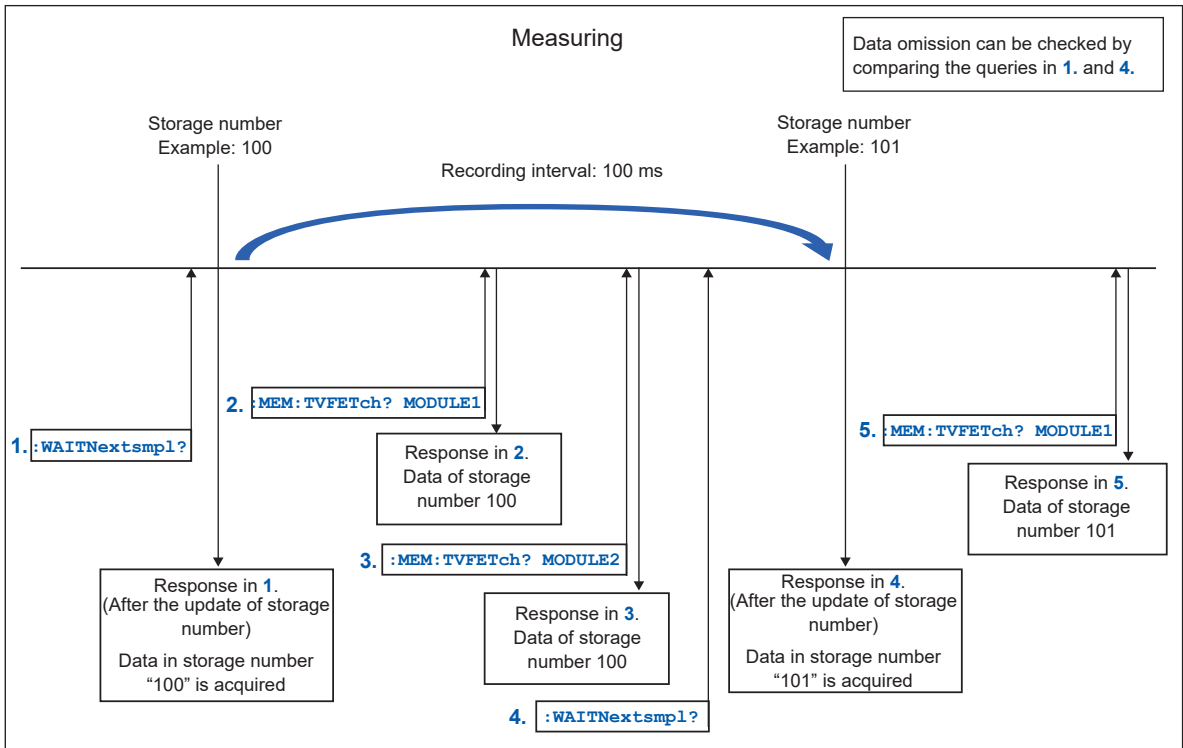

## 4.4 Conversion of Measurement Data

Use the following formula to convert an analog data value to a physical quantity.

Physical quantity = Data value × Voltage axis range/Number of data points per range

When the scaling is set:

Converted value = Physical quantity × Scaling coefficient + Scaling offset

The number of data points per range is described as follows.

| Modules        | Mode  | Number of data points per range<br>(For the 1 V range, the number of data points from 0 V to 1 V) |
|----------------|---|---|
| M7100<br>M7102 | Voltage (all ranges)<br>The 1 V to 5 V range is equivalent to 6 V | 100000  |
|                | Thermocouple (100°C range)  | 10000   |
|                | Thermocouple (500°C range)  | 10000   |
|                | Thermocouple (2000°C range)                                       | 20000   |

The measured value itself is returned as the data value of Aggregation and Waveform calculation.

To calculate the number of rotation, the data value needs to be divided by the number of pulses per rotation that is set with `:MODULE:PCOunt`.

Number of rotation = Data value / Number of pulses per rotation

For the alarm channel, the integer representation of all channels (1/4 bit) is returned (starting from the lowest bit, output in order of alarm 1, alarm 2...).

When the alarm channel data value is 9, alarm 1 and alarm 4 are output.

Example:  
Input type: Voltage  
Range: 6 V  
Scaling: Coefficient 2, offset 3  
Data value: 12356

Physical quantity =  $12356 \times 6/100000 = 0.74136$   
Converted value =  $0.74136 \times 2 + 3 = 4.48272$



If the scaling coefficient and offset for the target channel are unknown, use the queries of the following commands, regardless of the scaling conversion method.

`:SCALing:VOLT`  
`:SCALing:OFFSet`

See “(When the conversion method for scaling is set to the conversion ratio method)” (p. 110).

## 4.5 About Binary Data

The storage data are output in the binary format (big endian).

The binary format for each channel type is as follows.

- Logic and alarm channels: Output with the 1-data and 2-byte unit
- Analog and pulse channels: Output with the 1-data and 4-byte unit
- Waveform calculation channel: Output with the 1-data and 8-byte unit  
The response of the waveform calculation channel is output in the double precision floating point format of IEEE 754.

Method for converting data to physical quantity

See “4.4 Conversion of Measurement Data” (p. 133).

- When there is no data in the specified channel and output position  
The error value is output, which depends on the specified channels as shown in the table below.

|                              |                    |         |
|------------------------------|--------------------|---------|
| Analog channel               | 0x7ffffffd         | 4 bytes |
| Pulse channel                | 0x00000000         | 4 bytes |
| Waveform calculation channel | 0x7ff0000000000001 | 8 bytes |

- End of data  
Binary data may contain a newline (character code 0A or 0D).  
If the PC software being used interprets a newline as the end of the data, the data cannot be processed correctly. Therefore, make sure that the number of data specified with A are loaded.  
No newline (LF or CR+LF) is attached to the end of data.

## 4.6 Text (Physical Value)

When a text (physical value) is acquired, the number of decimal places varies depending on the specified channel.

When the scaling setting is enabled, the value after scaling is output.

Analog channel

7 significant figures \*<sup>1</sup>

Example: +1.234567E+03

Pulse channel

10 significant figures \*<sup>1</sup>

Example: +1.234567890E+03

Waveform calculation channel

12 significant figures \*<sup>1</sup>

Example: +1.23456789012E+03

Logic

Bi = 0 to 1

Example: 1

Alarm

Bi = 0 to 15

Example: 9

For the alarm channel, the integers representing all channels (4 bit) are returned (starting from the lowest bit, output in order of alarm 1, alarm 2...).

When the alarm channel data value is 9, alarm 1 and alarm 4 are output.

\*1. The decimal point position changes so that the exponential part is a multiple of 3.

Example: +1.234567E+03, +12.34567E+03, +123.4567E+03, +1.234567E+06

## 4.7 Comparison of Realtime Data Acquisition

|  |             | Logger Utility   | GENNECT One | Communication command   | UDP output   | CAN output  | XCP on Ethernet  |
|--|-------------|--|-------------|---|--|---|--|
| <b>Shortest sampling period</b>  |             | 10 ms  | 1 s         | 100 ms  | 5 ms   | 5 ms  | 5 ms   |
| <b>Number of instruments that can be handled (Number of units that can be synchronized for sampling)</b> |             | 5 units  | 10 units    | 10 units  | 10 units   | 10 units  | 10 units   |
| <b>Max. number of input channels that can be handled (Number of channels synchronized for sampling)</b>  |             | 600 channel  | 512 channel | 1500 channel (100 ms)<br>Up to 150 channels (5 modules) per unit<br><br>3000 channel (200 ms)<br>Up to 300 channels (10 modules) per unit                       | 800 channel (5 ms)<br>1500 channel (10 ms)<br>3000 channel (20 ms) | 150 channel (5 ms)<br>300 channel (10 ms)<br>600 channel (20 ms)<br><br>(Reference value when data are received using the CAN FD port only) | 800 channel (5 ms)<br>1500 channel (10 ms)<br>3000 channel (20 ms)<br><br>(For LAN2) |
| <b>Output port</b>   | <b>LAN1</b> | ✓  | ✓           | ✓*4   | -  | -   | ✓*1  |
|  | <b>LAN2</b> | -  | -           | -   | ✓  | -   | ✓  |
|  | <b>CAN</b>  | -  | -           | -   | -  | ✓   | -  |
| <b>How to obtain sample program</b>  |             | <ul style="list-style-type: none"> <li>Included on the provided DVD</li> <li>The latest version can be obtained from the Hioki website.*2</li> </ul> |             | <ul style="list-style-type: none"> <li>Sample program is included in the Instruction Manual (included on the provided DVD)</li> <li>Sequence Maker*3</li> </ul> | Sample program is included on the provided DVD                     | -   | -  |

\*1. XCP on Ethernet can be operated on LAN1. However, the operation conditions may be limited depending on the usage environment.

Reference: If 1,000,000 points of data are recorded, the data transfer time is approx. 2 seconds when `:MEMory:BDATA? 5000` is repeated 200 times.

(OS: Microsoft Windows 10 Pro (Ver 1903), CPU: Intel® i7-9700F 3.00 GHz, RAM: 16 GB)

This value is given only as a guide. The communication speed is not guaranteed. The communication speed varies depending on the usage environment.

\*2. <https://www.hioki.com/global/support/download/software/>

\*3. <https://sequencemaker.hioki.com/en/>

\*4. The number of input channels that can be handled with the communication command has been confirmed under the following environment. The number of channels that can be acquired varies depending on the usage environment and conditions.

Communication commands used: `:WAITNextsample?;:MEMory:TVFETch? MODULE 1` (executed for the number of modules)

Instrument (LR8102): The setting changes from the default status only during the recording interval

PC used: OS: Microsoft Windows 10 Pro (Ver 22H2), CPU: Intel® Core™ i5-8265U 1.60 GHz, RAM: 16 GB



# 5 Trigger Function

The trigger function allows you to specify conditions and signals to determine the timing for starting and stopping the measurement.

When the specified condition (trigger condition) is satisfied, the trigger is said to have been activated.

The position at which the trigger is activated (the trigger condition is satisfied) is called the “trigger point”.

You can set the instrument so that it starts and stops the recording when the triggers are activated. One of the following can be selected as the trigger source.

- Analog trigger (level, window)
- Pulse (level, window)
- Logic trigger (realization condition, pattern)
- Waveform calculation (level, window)
- Interval trigger
- External trigger

The following specific conditions can be set for the instrument.

| Specific conditions            | Description  | Reference |
|--------------------------------|--|-----------|
| Start trigger                  | The recording is started from the moment the trigger condition is satisfied.<br>Example: Recording is started if the temperature rises to 50°C or higher | p. 139    |
| Stop trigger                   | Recording is stopped at the moment the trigger condition is satisfied.<br>Example: Recording is stopped if the signal falls below 1 V                    | p. 139    |
| External trigger               | The trigger is activated with an external signal. (I/O 3)<br>Example: Recording is started in accordance with the operation of other devices             | p. 153    |
| Pre-trigger                    | Data before the trigger point is also recorded.<br>Example: Phenomena before an error occurs are also recorded   | p. 140    |
| Interval trigger               | The trigger can be activated at constant intervals.<br>Example: Recording is performed hourly  | p. 154    |
| Trigger satisfaction condition | You can set the condition under which the trigger is satisfied.<br>Select AND/OR between the triggers.   | p. 140    |

## IMPORTANT

- If the trigger function is disabled, the recording is started when the **START** command is executed (free run).
- When the trigger function is enabled, the “trigger standby” is kept until the trigger condition is satisfied. The recording is started if the trigger condition is satisfied.
- When pre-trigger is used, the trigger is not activated with recovered data. In addition, the data during the pre-trigger standby is not recovered.
- The next trigger cannot be accepted while a trigger is being processed. The trigger output turns active while a trigger is being processed. For the trigger output, see **(p.247)**.



## 5.1 Trigger Contents

Set the conditions for starting or stopping the measurement.

Set the conditions with the trigger type (level, window, pattern) and slope (signal rise, fall).

### Trigger type

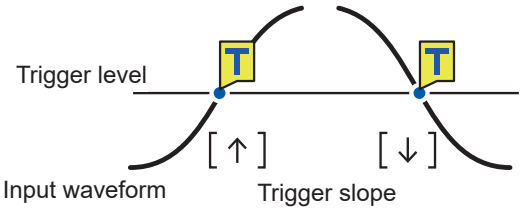
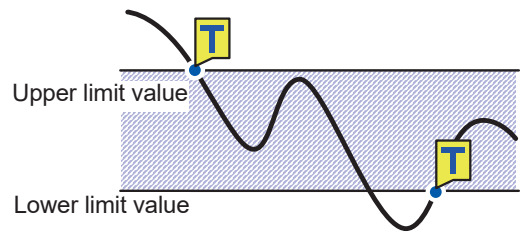
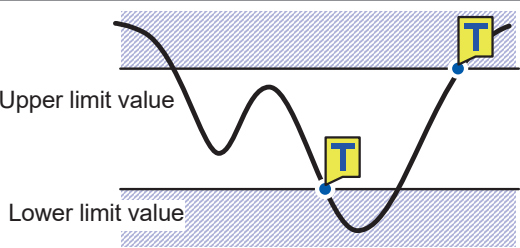
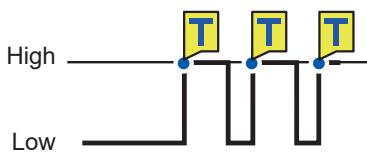
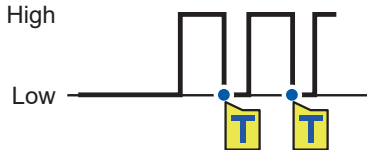
There are the following three types.

| Type            |     | Operation  | Description   |
|-----------------|-----|--|---|
| Level trigger   | ↑   |    | The trigger is activated when the waveform crosses above the level. The value equivalent to the level is included.  |
|                 | ↓   |  | The trigger is activated when the waveform crosses below the specified level. However, the trigger is not activated if the waveform falls to become equal to the level value.* <sup>1</sup>   |
| Window trigger  | IN  |   | The trigger is activated when the waveform enters the range between the upper and lower limit values. The value equivalent to the upper or lower limit value is included.   |
|                 | OUT |  | The trigger is activated when the waveform exits the range between the upper and lower limit values. However, the trigger is not activated if the waveform rises to become equal to the upper limit value, or if the waveform falls to become equal to the lower limit value.* <sup>2</sup> |
| Pattern trigger | 1   |   | The trigger is activated when the logic signal turns into 1.  |
|                 | 0   |   | The trigger is activated when the logic signal turns into 0.  |
|                 | X   |   | Ignores the signal. No trigger is activated.  |

\*1. For the pulse channel, the trigger activates when the pulse decreases to zero, provided that the level value is set to zero.

\*2. For the pulse channel, the trigger activates when the pulse decreases to zero, provided that the lower limit value is set to zero. Similarly, the trigger activates when the pulse increases to zero, provided that the upper limit value is set to zero.

# 5.2 Enabling the Trigger Function

Methods for starting and stopping the measurement using the trigger function are introduced here.

## Common settings

### 1 Set the trigger to ON.

| Settings         |   |                  |
|------------------|---|------------------|
| Syntax           | Command   | :TRIGger:SET A\$ |
| Example          | :TRIGger:SET ON   |                  |
| Query            |   |                  |
| Syntax           | Query   | :TRIGger:SET?    |
|                  | Response  | A\$              |
| Example          | :TRIGger:SET?<br>(Response) :TRIGGER:SET ON (When the header is ON) |                  |
| Parameter        |   |                  |
| A\$ = OFF, ON    |   |                  |
| OFF <sup>☑</sup> | Trigger disabled  |                  |
| ON               | Trigger enabled   |                  |

### 2 Set the behavior when the trigger is activated.

| Settings               |  |                     |
|------------------------|--|---------------------|
| Syntax                 | Command  | :TRIGger:TIMIng A\$ |
| Example                | :TRIGger:TIMIng START  |                     |
| Query                  |  |                     |
| Syntax                 | Query  | :TRIGger:TIMIng?    |
|                        | Response   | A\$                 |
| Example                | :TRIGger:TIMIng?<br>(Response) :TRIGGER:TIMING START (When the header is ON)   |                     |
| Parameter              |  |                     |
| A\$ = START, STOP, S_S |  |                     |
| START <sup>☑</sup>     | Start trigger<br>The recording begins when the trigger condition is satisfied (start trigger).   |                     |
| STOP                   | Stop trigger<br>The recording stops when the trigger condition is satisfied (stop trigger).  |                     |
| S_S                    | Start and stop triggers<br>The recording begins when the start trigger condition is satisfied, and the recording stops when the stop trigger condition is satisfied. |                     |

### 3 Configure the amount of time or number of days to record before the trigger is activated.

Data before the trigger point (the moment the trigger is activated) can be recorded. This is useful for problem analyses, because the data before an abnormal phenomenon occurs can be recorded. If the operation when the trigger is activated is set to **STOP**, the pre-trigger is disabled.

#### Pre-trigger

| Settings  |                   |  |
|-----------|-------------------|--|
| Syntax    | Command           | :TRIGger:PRETrig day, hour, min, sec   |
| Example   |                   | :TRIGger:PRETrig 0, 0, 0, 10   |
| Query     |                   |  |
| Syntax    | Query             | :TRIGger:PRETrig?  |
|           | Response          | day<NR1>, hour<NR1>, min<NR1>, sec<NR1>  |
| Example   |                   | :TRIGger:PRETrig?<br>(Response) :TRIGGER:PRETRIG 0, 0, 0, 10 (When the header is ON) |
| Parameter |                   |  |
| day       | 0 to 99 (days)    |  |
| hour      | 0 to 23 (hours)   |  |
| min       | 0 to 59 (minutes) |  |
| sec       | 0 to 59 (seconds) |  |

See "Data part" (p. 23).

A time range for up to 100,000 samples can be set. However, the range cannot be set to 100 days or longer. If a value exceeding the allowable setting range is specified, only the setting value allowed for each parameter should be set.

When an external sampling is used, this parameter cannot be set.

|   |  |
|---|--|
|  | To continue the recording of waveform after the trigger, set the recording time longer than the pre-trigger. |
|---|--|

### 4 Set the condition under which the trigger is satisfied.

Set the conditions for activation between various types of triggers (analog, pulse, logic, waveform calculation, external, and interval) using logical AND or logical OR operations.

When all trigger sources are OFF (no trigger is set), the recording is started immediately (free run). The trigger conditions need to be set separately for the start and stop triggers.

#### AND/OR between the start trigger sources

| Settings        |   |  |
|-----------------|---|--|
| Syntax          | Command   | :TRIGger:SOURce A\$  |
| Example         |   | :TRIGger:SOURce AND  |
| Query           |   |  |
| Syntax          | Query   | :TRIGger:SOURce?   |
|                 | Response  | A\$  |
| Example         |   | :TRIGger:SOURce?<br>(Response) :TRIGGER:SOURCE AND (When the header is ON) |
| Parameter       |   |  |
| A\$ = OR, AND   |   |  |
| OR <sup>☐</sup> | Logical sum<br>The trigger is activated if any one of the trigger conditions is satisfied. Trigger satisfaction condition is judged with edge.          |  |
| AND             | Logical multiplication<br>The trigger is activated if all of the trigger conditions are satisfied. Trigger satisfaction condition is judged with level. |  |

### AND/OR between the stop trigger sources

| Settings        |   |                      |
|-----------------|---|----------------------|
| Syntax          | Command   | :TRIGger:SSOURce A\$ |
| Example         | :TRIGger:SSOURce AND  |                      |
| Query           |   |                      |
| Syntax          | Query   | :TRIGger:SSOURce?    |
|                 | Response  | :A\$                 |
| Example         | :TRIGger:SSOURce?<br>(Response) :TRIGGER:SSOURCE AND (When the header is ON)  |                      |
| Parameter       |   |                      |
| A\$ = OR, AND   |   |                      |
| OR <sup>Ⓜ</sup> | Logical sum<br>The trigger is activated if any one of the trigger conditions is satisfied. Trigger satisfaction condition is judged with edge.          |                      |
| AND             | Logical multiplication<br>The trigger is activated if all of the trigger conditions are satisfied. Trigger satisfaction condition is judged with level. |                      |

If the trigger condition is satisfied at the moment the measurement begins, no trigger is activated. The trigger is activated if the trigger condition is changed from the unsatisfied to satisfied status.

Example: The trigger is activated when the waveform crosses 0 V from below to above.

Type: Level trigger  
Level: 0 V  
Slope: ↑

[OR]

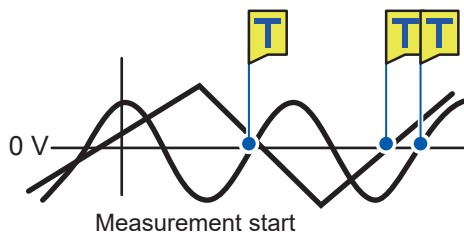

The trigger is activated when one crosses 0 V from below to above.

[AND]

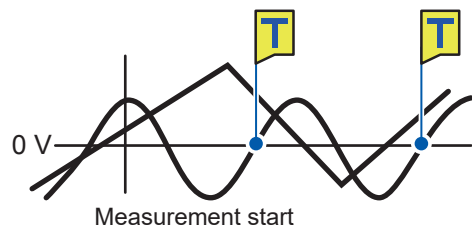

The trigger is activated when one is above 0 V and the other crosses 0 V from below to above.

### Difference between the pre-trigger standby and trigger standby

When measurement is started, the trigger acceptance is prohibited for the time specified for the pre-trigger. After the time for the pre-trigger elapses, establishment of the trigger condition is waited. The status during this period is trigger standby. During the pre-trigger standby, the trigger is not activated even if the trigger condition is satisfied.

### Relationship between the pre-trigger and recording time

**When the recording time is shorter than the pre-trigger**

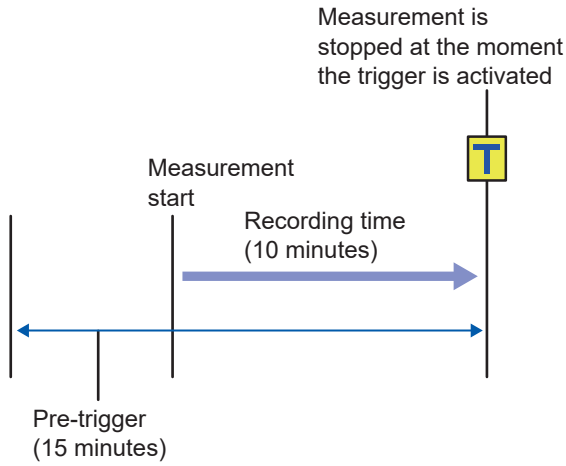

**When the recording time is longer than the pre-trigger**

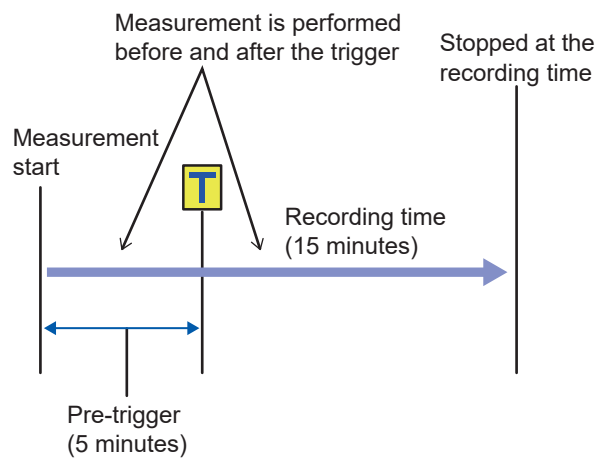

## 5.3 Analog Trigger, Pulse Trigger, and Waveform Calculation Trigger

The triggers can be set separately for the analog channel, pulse channel, and waveform calculation channel.

The following triggers can be set.

- Level trigger
- Window trigger

### Level trigger

The trigger is activated when the waveform crosses the specified level (trigger level). You can set the direction in which the waveform should cross the level (slope).

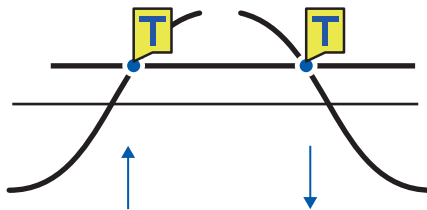

# 1 Set the trigger type to LEVEL.

| Settings   |   |   |
|--|---|---|
| <b>Syntax</b>  | Command   | Analog channel trigger<br>:TRIGger:ANALog:START:KIND ch\$,A\$ (Start trigger)<br>:TRIGger:ANALog:STOP:KIND ch\$,A\$ (Stop trigger)<br>Waveform calculation channel trigger<br>:TRIGger:CALCulate:START:KIND w\$,A\$ (Start trigger)<br>:TRIGger:CALCulate:STOP:KIND w\$,A\$ (Stop trigger)<br>Pulse channel trigger<br>:TRIGger:PULSe:START:KIND pls\$,A\$ (Start trigger)<br>:TRIGger:PULSe:STOP:KIND pls\$,A\$ (Stop trigger) |
| <b>Example</b>   | :TRIGger:ANALog:START:KIND CH1_1,LEVEL  |   |
| Query  |   |   |
| <b>Syntax</b>  | Query   | Analog channel trigger<br>:TRIGger:ANALog:START:KIND? ch\$ (Start trigger)<br>:TRIGger:ANALog:STOP:KIND? ch\$ (Stop trigger)<br>Waveform calculation channel trigger<br>:TRIGger:CALCulate:START:KIND? w\$ (Start trigger)<br>:TRIGger:CALCulate:STOP:KIND? w\$ (Stop trigger)<br>Pulse channel trigger<br>:TRIGger:PULSe:START:KIND? pls\$ (Start trigger)<br>:TRIGger:PULSe:STOP:KIND? pls\$ (Stop trigger)                   |
|  | Response  | Analog channel trigger<br>ch\$,A\$<br>Waveform calculation channel trigger<br>w\$,A\$<br>Pulse channel trigger<br>pls\$,A\$   |
| <b>Example</b>   | :TRIGger:ANALog:START:KIND? CH1_1<br>(Response) :TRIGGER:ANALOG:START:KIND CH1_1,LEVEL<br>(When the header is ON) |   |
| Parameter  |   |   |
| ch\$ = CH1_1 to CH10_30<br>w\$ = W1 to W30<br>pls\$ = PLS1<br>A\$ = OFF, LEVEL, WINDOW |   |   |
| OFF <sup>☑</sup>   | The trigger is not judged.  |   |
| LEVEL  | The trigger is judged with the specified level.   |   |
| WINDOW   | The trigger is judged with the range between the specified upper and lower limits (window).                       |   |



## 2 Set the slope.

The trigger is activated when the waveform crosses the level in the specified direction. When the trigger condition is set to AND, it is judged whether or not the waveform is above the specified level.

| Settings   |   |   |
|--|---|---|
| <b>Syntax</b>  | Command   | Analog channel trigger<br>:TRIGger:ANALog:START:SLOPe ch\$,A\$ (Start trigger)<br>:TRIGger:ANALog:STOP:SLOPe ch\$,A\$ (Stop trigger)<br>Waveform calculation channel trigger<br>:TRIGger:CALCulate:START:SLOPe w\$,A\$ (Start trigger)<br>:TRIGger:CALCulate:STOP:SLOPe w\$,A\$ (Stop trigger)<br>Pulse channel trigger<br>:TRIGger:PULSe:START:SLOPe pls\$,A\$ (Start trigger)<br>:TRIGger:PULSe:STOP:SLOPe pls\$,A\$ (Stop trigger) |
| <b>Example</b>   | :TRIGger:ANALog:START:SLOPe CH1_1,UP  |   |
| Query  |   |   |
| <b>Syntax</b>  | Query   | Analog channel trigger<br>:TRIGger:ANALog:START:SLOPe? ch\$ (Start trigger)<br>:TRIGger:ANALog:STOP:SLOPe? ch\$ (Stop trigger)<br>Waveform calculation channel trigger<br>:TRIGger:CALCulate:START:SLOPe? w\$ (Start trigger)<br>:TRIGger:CALCulate:STOP:SLOPe? w\$ (Stop trigger)<br>Pulse channel trigger<br>:TRIGger:PULSe:START:SLOPe? pls\$ (Start trigger)<br>:TRIGger:PULSe:STOP:SLOPe? pls (Stop trigger)                     |
|  | Response  | Analog channel trigger<br>ch\$,A\$<br>Waveform calculation channel trigger<br>w\$,A\$<br>Pulse channel trigger<br>pls\$,A\$   |
| <b>Example</b>   | :TRIGger:ANALog:START:SLOPe? CH1_1<br>(Response) :TRIGGER:ANALOG:START:SLOPE CH1_1,UP (When the header is ON) |   |
| Parameter  |   |   |
| ch\$ = CH1_1 to CH10_30<br>w\$ = W1 to W30<br>pls\$ = PLS1<br>A\$ = UP, DOWN |   |   |
| <b>UP</b> <sup>☐</sup>   | Rise  | The waveform crosses the specified level from below to above.   |
| <b>DOWN</b>  | Fall  | The waveform crosses below the specified level from above .   |

### 3 Set the trigger level.

The trigger is activated when the waveform crosses the specified level (temperature, voltage, etc.). When the scaling function is used, the value after scaling conversion can be used for setting the trigger level.

| Settings  |  |   |
|---|--|---|
| <b>Syntax</b>   | Command  | Analog channel trigger<br>:TRIGger:ANALog:START:LEVEL ch\$,A (Start trigger)<br>:TRIGger:ANALog:STOP:LEVEL ch\$,A (Stop trigger)<br>Waveform calculation channel trigger<br>:TRIGger:CALCulate:START:LEVEL w\$,A (Start trigger)<br>:TRIGger:CALCulate:STOP:LEVEL w\$,A (Stop trigger)<br>Pulse channel trigger<br>:TRIGger:PULSe:START:LEVEL pls\$,A (Start trigger)<br>:TRIGger:PULSe:STOP:LEVEL pls\$,A (Stop trigger) |
| <b>Example</b>  | :TRIGger:ANALog:START:LEVEL CH1_1,0.1  |   |
| Query   |  |   |
| <b>Syntax</b>   | Query  | Analog channel trigger<br>:TRIGger:ANALog:START:LEVEL? ch\$ (Start trigger)<br>:TRIGger:ANALog:STOP:LEVEL? ch\$ (Stop trigger)<br>Waveform calculation channel trigger<br>:TRIGger:CALCulate:START:LEVEL? w\$ (Start trigger)<br>:TRIGger:CALCulate:STOP:LEVEL? w\$ (Stop trigger)<br>Pulse channel trigger<br>:TRIGger:PULSe:START:LEVEL? pls\$ (Start trigger)<br>:TRIGger:PULSe:STOP:LEVEL? pls\$ (Stop trigger)       |
|   | Response   | Analog channel trigger<br>ch\$,A<NR3> (3 digit after the decimal point)<br>Waveform calculation channel trigger<br>w\$,A<NR3> (4 digits after the decimal point)<br>Pulse channel trigger<br>pls\$,A<NR3> (9 digits after the decimal point)  |
| <b>Example</b>  | :TRIGger:ANALog:START:LEVEL? CH1_1<br>(Response) :TRIGGER:ANALOG:START:LEVEL CH1_1,+1.000E-01<br>(When the header is ON) |   |
| Parameter   |  |   |
| ch\$ = CH1_1 to CH10_30<br>w\$ = W1 to W30<br>pls\$ = PLS1<br><br>Analog channel trigger<br>A = Allowable setting range: (Measurement range) × (±1.5),<br>Maximum resolution: (Measurement range) × (1/1000) <sup>*1</sup><br><br>Waveform calculation channel trigger<br>A = -9.9999E+29 to 9.9999E+29<br><br>Pulse channel trigger<br>A = 0 to 1000000000 (count), 0 to 15000 (r/s),<br>0 to 900000 (r/min)<br>*1. When scaling is used, set the value after scaling.<br><br>Example:<br>For 1 V range<br>A = Allowable setting range: +1.5 V to -1.5 V<br>Maximum resolution: 1 mV<br><br>When scaling is used with the 1 V range (1 V → 10 A)<br>A = Allowable setting range: +15 A to -15 V<br>Maximum resolution: 10 mV |  |   |

## Trigger level resolution

The trigger level resolution (minimum setting width) depends on the ranges.

| Input                      | Range         | Resolution |
|----------------------------|---------------|------------|
| Voltage                    | 1 mV f.s.     | 0.001 mV   |
|                            | 2 mV f.s.     | 0.002 mV   |
|                            | 5 mV f.s.     | 0.005 mV   |
|                            | 10 mV f.s.    | 0.01 mV    |
|                            | 20 mV f.s.    | 0.02 mV    |
|                            | 50 mV f.s.    | 0.05 mV    |
|                            | 100 mV f.s.   | 0.1 mV     |
|                            | 200 mV f.s.   | 0.2 mV     |
|                            | 1 V f.s.      | 0.001 V    |
|                            | 2 V f.s.      | 0.002 V    |
|                            | 6 V f.s.      | 0.006 V    |
|                            | 10 V f.s.     | 0.01 V     |
|                            | 20 V f.s.     | 0.02 V     |
|                            | 60 V f.s.     | 0.06 V     |
|                            | 100 V f.s.    | 0.1 V      |
| 1-5 V f.s.                 | 0.01 V        |            |
| Temperature (thermocouple) | 100°C f.s.    | 0.1°C      |
|                            | 500°C f.s.    | 0.5°C      |
|                            | 2000°C f.s.   | 2°C        |
| Count                      | –             | 1 c        |
| Rotation speed             | 5000 r/s      | 1 r/s      |
|                            | 300,000 r/min | 1 r/min    |

## Window trigger

You can specify a range with upper and lower limit values (window), so that the trigger is activated when the waveform enters or exits the range.

The trigger can be activated when the waveform enters the range (window IN) as well as when the waveform exits the range (window OUT).

**Window IN**

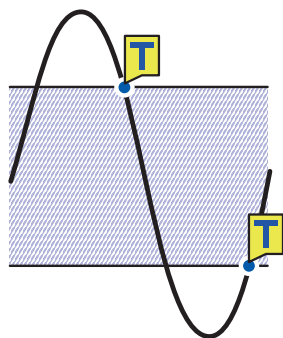

**Window OUT**

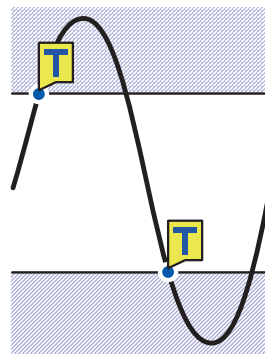

# 1 Set the trigger type to WINDOW.

| Settings   |  |   |
|--|--|---|
| Syntax   | Command  | Analog channel trigger<br>:TRIGger:ANALog:START:KIND ch\$,A\$ (Start trigger)<br>:TRIGger:ANALog:STOP:KIND ch\$,A\$ (Stop trigger)<br>Waveform calculation channel trigger<br>:TRIGger:CALCulate:START:KIND w\$,A\$ (Start trigger)<br>:TRIGger:CALCulate:STOP:KIND w\$,A\$ (Stop trigger)<br>Pulse channel trigger<br>:TRIGger:PULSe:START:KIND pls\$,A\$ (Start trigger)<br>:TRIGger:PULSe:STOP:KIND pls\$,A\$ (Stop trigger) |
| Example  | :TRIGger:ANALog:START:KIND CH1_1,WINDOW  |   |
| Query  |  |   |
| Syntax   | Query  | Analog channel trigger<br>:TRIGger:ANALog:START:KIND? ch\$ (Start trigger)<br>:TRIGger:ANALog:STOP:KIND? ch\$ (Stop trigger)<br>Waveform calculation channel trigger<br>:TRIGger:CALCulate:START:KIND? w\$ (Start trigger)<br>:TRIGger:CALCulate:STOP:KIND? w\$ (Stop trigger)<br>Pulse channel trigger<br>:TRIGger:PULSe:START:KIND? pls\$ (Start trigger)<br>:TRIGger:PULSe:STOP:KIND? pls\$ (Stop trigger)                   |
|  | Response   | Analog channel trigger<br>ch\$,A\$<br>Waveform calculation channel trigger<br>w\$,A\$<br>Pulse channel trigger<br>pls\$,A\$   |
| Example  | :TRIGger:ANALog:START:KIND? CH1_1<br>(Response) :TRIGGER:ANALOG:START:KIND CH1_1,WINDOW<br>(When the header is ON) |   |
| Parameter  |  |   |
| ch\$ = CH1_1 to CH10_30<br>w\$ = W1 to W30<br>pls\$ = PLS1<br>A\$ = OFF, LEVEL, WINDOW |  |   |
| OFF <sup>□</sup>   | The trigger is not judged.   |   |
| LEVEL  | The trigger is judged with the specified level.  |   |
| WINDOW   | The trigger is judged with the range between the specified upper and lower limits (window).                        |   |

## 2 Set IN/OUT of waveform.

When the trigger condition is set to AND, it is judged whether or not the waveform exists within the specified range.

| Settings  |  |   |
|---|--|---|
| <b>Syntax</b>   | Command  | Analog channel trigger<br>:TRIGger:ANALog:START:SIDE ch\$,A\$ (Start trigger)<br>:TRIGger:ANALog:STOP:SIDE ch\$,A\$ (Stop trigger)<br>Waveform calculation channel trigger<br>:TRIGger:CALCulate:START:SIDE w\$,A\$ (Start trigger)<br>:TRIGger:CALCulate:STOP:SIDE w\$,A\$ (Stop trigger)<br>Pulse channel trigger<br>:TRIGger:PULSe:START:SIDE pls\$,A\$ (Start trigger)<br>:TRIGger:PULSe:STOP:SIDE pls\$,A\$ (Stop trigger) |
| <b>Example</b>  | :TRIGger:ANALog:START:SIDE CH1_1, IN   |   |
| Query   |  |   |
| <b>Syntax</b>   | Query  | Analog channel trigger<br>:TRIGger:ANALog:START:SIDE? ch\$ (Start trigger)<br>:TRIGger:ANALog:STOP:SIDE? ch\$ (Stop trigger)<br>Waveform calculation channel trigger<br>:TRIGger:CALCulate:START:SIDE? w\$ (Start trigger)<br>:TRIGger:CALCulate:STOP:SIDE? w\$ (Stop trigger)<br>Pulse channel trigger<br>:TRIGger:PULSe:START:SIDE? pls\$ (Start trigger)<br>:TRIGger:PULSe:STOP:SIDE? pls\$ (Stop trigger)                   |
|   | Response   | Analog channel trigger<br>ch\$,A\$<br>Waveform calculation channel trigger<br>w\$,A\$<br>Pulse channel trigger<br>pls\$,A\$   |
| <b>Example</b>  | :TRIGger:ANALog:START:SIDE? CH1_1<br>(Response) :TRIGGER:ANALOG:START:SIDE CH1_1, IN (When the header is ON) |   |
| Parameter   |  |   |
| ch\$ = CH1_1 to CH10_30<br>w\$ = W1 to W30<br>pls\$ = PLS1<br>A\$ = IN, OUT |  |   |
| <b>IN</b> <sup>□</sup>  | Window IN<br>The trigger is activated when the waveform enters the specified range.                          |   |
| <b>OUT</b>  | Window OUT<br>The trigger is activated when the waveform exits the specified range.                          |   |

### 3 Set the upper and lower limit values.

The range between the upper and lower limit values is defined as the window.

#### Upper limit value

| Settings  |  |   |
|---|--|---|
| Syntax  | Command  | Analog channel trigger<br>:TRIGger:ANALog:START:UPPER ch\$,A (Start trigger)<br>:TRIGger:ANALog:STOP:UPPER ch\$,A (Stop trigger)<br>Waveform calculation channel trigger<br>:TRIGger:CALCulate:START:UPPER w\$,A (Start trigger)<br>:TRIGger:CALCulate:STOP:UPPER w\$,A (Stop trigger)<br>Pulse channel trigger<br>:TRIGger:PULSe:START:UPPER pls\$,A (Start trigger)<br>:TRIGger:PULSe:STOP:UPPER pls\$,A (Stop trigger) |
| Example   | :TRIGger:ANALog:START:UPPER CH1_1,0.5  |   |
| Query   |  |   |
| Syntax  | Query  | Analog channel trigger<br>:TRIGger:ANALog:START:UPPER? ch\$ (Start trigger)<br>:TRIGger:ANALog:STOP:UPPER? ch\$ (Stop trigger)<br>Waveform calculation channel trigger<br>:TRIGger:CALCulate:START:UPPER? w\$ (Start trigger)<br>:TRIGger:CALCulate:STOP:UPPER? w\$ (Stop trigger)<br>Pulse channel trigger<br>:TRIGger:PULSe:START:UPPER? pls\$ (Start trigger)<br>:TRIGger:PULSe:STOP:UPPER? pls\$ (Stop trigger)       |
|   | Response   | Analog channel trigger<br>ch\$,A<NR3> (3 digit after the decimal point)<br>Waveform calculation channel trigger<br>w\$,A<NR3> (4 digits after the decimal point)<br>Pulse channel trigger<br>pls\$,A<NR3> (9 digits after the decimal point)  |
| Example   | :TRIGger:ANALog:START:UPPER? CH1_1<br>(Response) :TRIGGER:ANALOG:START:UPPER CH1_1,+5.000E-01<br>(When the header is ON) |   |
| Parameter   |  |   |
| ch\$ = CH1_1 to CH10_30<br>w\$ = W1 to W30<br>pls\$ = PLS1<br><br>Analog channel trigger<br>A = Allowable setting range: (Measurement range) × (±1.5),<br>Maximum resolution: (Measurement range) × (1/1000)<br><br>Waveform calculation channel trigger<br>A = -9.9999E+29 to 9.9999E+29<br><br>Pulse channel trigger<br>A = 0 to 1000000000 (count), 0 to 15000 (r/s),<br>0 to 900000 (r/min) |  |   |

## Lower limit value

| Settings  |  |   |
|---|--|---|
| <b>Syntax</b>   | Command  | Analog channel trigger<br>:TRIGger:ANALog:START:LOWEr ch\$,A (Start trigger)<br>:TRIGger:ANALog:STOP:LOWEr ch\$,A (Stop trigger)<br>Waveform calculation channel trigger<br>:TRIGger:CALCulate:START:LOWEr w\$,A (Start trigger)<br>:TRIGger:CALCulate:STOP:LOWEr w\$,A (Stop trigger)<br>Pulse channel trigger<br>:TRIGger:PULSe:START:LOWEr pls\$,A (Start trigger)<br>:TRIGger:PULSe:STOP:LOWEr pls\$,A (Stop trigger) |
| <b>Example</b>  | :TRIGger:ANALog:START:LOWEr CH1_1,-0.5   |   |
| Query   |  |   |
| <b>Syntax</b>   | Query  | Analog channel trigger<br>:TRIGger:ANALog:START:LOWEr? ch\$ (Start trigger)<br>:TRIGger:ANALog:STOP:LOWEr? ch\$ (Stop trigger)<br>Waveform calculation channel trigger<br>:TRIGger:CALCulate:START:LOWEr? w\$ (Start trigger)<br>:TRIGger:CALCulate:STOP:LOWEr? w\$ (Stop trigger)<br>Pulse channel trigger<br>:TRIGger:PULSe:START:LOWEr? pls\$ (Start trigger)<br>:TRIGger:PULSe:STOP:LOWEr? pls\$ (Stop trigger)       |
|   | Response   | Analog channel trigger<br>ch\$,A<NR3> (3 digit after the decimal point)<br>Waveform calculation channel trigger<br>w\$,A<NR3> (4 digits after the decimal point)<br>Pulse channel trigger<br>pls\$,A<NR3> (9 digits after the decimal point)  |
| <b>Example</b>  | :TRIGger:ANALog:START:LOWEr? CH1_1<br>(Response) :TRIGGER:ANALOG:START:LOWEr CH1_1,-5.000E-01<br>(When the header is ON) |   |
| Parameter   |  |   |
| ch\$ = CH1_1 to CH10_30<br>w\$ = W1 to W30<br>pls\$ = PLS1<br><br>Analog channel trigger<br>A = Allowable setting range: (Measurement range) × (±1.5),<br>Maximum resolution: (Measurement range) × (1/1000)<br><br>Waveform calculation channel trigger<br>A = -9.9999E+29 to 9.9999E+29<br><br>Pulse channel trigger<br>A = 0 to 1000000000 (count), 0 to 15000 (r/s),<br>0 to 900000 (r/min) |  |   |

## 5.4 Logic Trigger (Pattern)

The trigger can be activated using the logic signal.

The trigger is activated when the logic signal value (1 and 0) matches the trigger pattern (1, 0, or X).

This setting is enabled when LOGIC is selected for the pulse (P1) input.

See "Logic signal measurement" (p. 107).

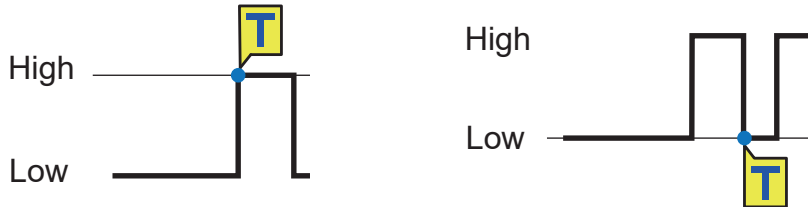

### 1 Select the trigger pattern for P1.

Enable the pulse measurement channel.

| Settings                         |  |  |
|----------------------------------|--|--|
| Syntax                           | Command  | :TRIGger:LOGic:START:PATtern "A\$" (Start trigger)<br>:TRIGger:LOGic:STOP:PATtern "A\$" (Stop trigger) |
| Example                          | :TRIGger:LOGic:START:PATtern "1"   |  |
| Query                            |  |  |
| Syntax                           | Query  | :TRIGger:LOGic:START:PATtern? (Start trigger)<br>:TRIGger:LOGic:STOP:PATtern? (Stop trigger)           |
|                                  | Response   | "A\$"  |
| Example                          | :TRIGger:LOGic:START:PATtern?<br>(Response) :TRIGGER:LOGIC:START:PATTERN "1" (When the header is ON) |  |
| Parameter                        |  |  |
| A\$ = 0, 1, X<br>Trigger pattern |  |  |
| 0                                | The trigger is activated when the signal turns into 0 (Low).   |  |
| 1                                | The trigger is activated when the signal turns into 1 (High).  |  |
| X <sup>☐</sup>                   | The trigger is not applicable. Ignores the signal.   |  |



## 5.5 Applying External Trigger

The trigger can be activated with the input signal to the I/O 3 terminal of the external control terminal.

### 1 Enable the external trigger function.

| Settings   |   |  |
|--|---|--|
| <b>Syntax</b>  | Command   | <code>:TRIGger:EXtErnal:START:KIND A\$</code> (Start trigger)<br><code>:TRIGger:EXtErnal:STOP:KIND A\$</code> (Stop trigger) |
| <b>Example</b>                                       | <code>:TRIGger:EXtErnal:START:KIND ON</code>  |  |
| Query  |   |  |
| <b>Syntax</b>  | Query   | <code>:TRIGger:EXtErnal:START:KIND?</code> (Start trigger)<br><code>:TRIGger:EXtErnal:STOP:KIND?</code> (Stop trigger)       |
|  | Response  | <code>A\$</code>   |
| <b>Example</b>                                       | <code>:TRIGger:EXtErnal:START:KIND?</code><br>(Response) <code>:TRIGGER:EXTERNAL:START:KIND ON</code> (When the header is ON) |  |
| Parameter  |   |  |
| <code>A\$</code> = OFF, ON                           |   |  |
| <code>OFF</code> <input checked="" type="checkbox"/> | Disabled  |  |
| <code>ON</code>                                      | Activated   |  |

The external trigger function is enabled, allowing you to apply a trigger with the external input signal.

When the external trigger is enabled, the I/O 3 terminal is set to the trigger input.

## 5.6 Applying Triggers at Constant Intervals

The trigger can be activated at constant time intervals.  
 If the interval trigger is set to **OR** or **AND**, the repetitive recording is automatically set to ON.  
 The interval trigger is disabled when using Logger Utility.  
 When an external sampling is used, the interval trigger is disabled.

### 1 Set the interval trigger condition.

To prioritize the interval trigger, set the parameter to **OR**.  
 To prioritize other triggers, set the parameter to **AND**.

| Settings                                |  |                    |
|---|--|--------------------|
| Syntax                                  | Command  | :TRIGger:TIMEr A\$ |
| Example                                 | :TRIGger:TIMEr OR  |                    |
| Query                                   |  |                    |
| Syntax                                  | Query  | :TRIGger:TIMEr?    |
|   | Response   | A\$                |
| Example                                 | :TRIGger:TIMEr?<br>(Response) :TRIGGER:TIMER OR (When the header is ON)        |                    |
| Parameter                               |  |                    |
| A\$ = OFF, OR, AND                      |  |                    |
| OFF <input checked="" type="checkbox"/> | Disabled<br>The interval trigger is not used.                                  |                    |
| OR                                      | Logical sum<br>The interval trigger is used with the OR condition.             |                    |
| AND                                     | Logical multiplication<br>The interval trigger is used with the AND condition. |                    |

### 2 Set the interval of the interval trigger.

The trigger condition is satisfied as soon as the measurement is started. After that, the trigger is activated at the intervals of the interval trigger.

| Settings  |  |   |
|-----------|--|---|
| Syntax    | Command  | :TRIGger:TMINTv1 day, hour, min, sec    |
| Example   | :TRIGger:TMINTv1 1, 20, 30, 00   |   |
| Query     |  |   |
| Syntax    | Query  | :TRIGger:TMINTv1?                       |
|           | Response   | day<NR1>, hour<NR1>, min<NR1>, sec<NR1> |
| Example   | :TRIGger:TMINTv1?<br>(Response) :TRIGGER:TMINTVL 1, 20, 30, 00 (When the header is ON) |   |
| Parameter |  |   |
| day       | 0 to 99 (days)   |   |
| hour      | 0 to 23 (hours)  |   |
| min       | 0 to 59 (minutes)  |   |
| sec       | 0 to 59 (seconds)  |   |

The current setting of the recording time is returned with a numerical value in the NR1 format.  
 See "Data part" (p. 23).

### OR condition and AND condition

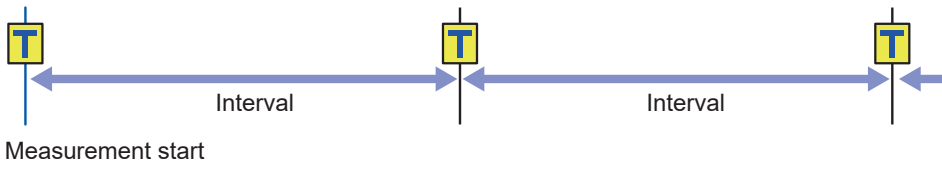
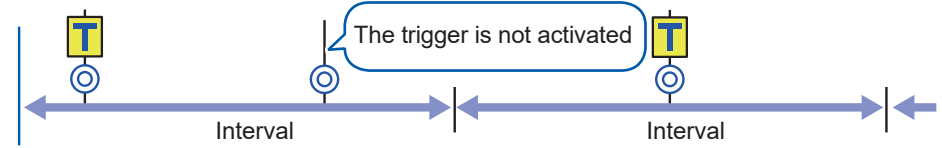
| Trigger condition | <b>T</b> : Trigger point, <b>⊙</b> : Other trigger conditions  |
|-------------------|--|
| <b>OR</b>         |  <p>Measurement start</p>  |
| <b>AND</b>        | <p>One trigger is valid within one interval.</p>  <p>Measurement start</p> <p>The trigger is not activated unless another trigger condition matches (if no other trigger condition is set, the operation is performed as with the OR condition).</p> |

## 5.7 Applying Trigger Forcibly

The trigger can be forcibly activated in the trigger standby state.

The forcible trigger can be activated regardless of the trigger source setting.

### 1 Activate the trigger forcibly.

| Settings |                 |                 |
|----------|-----------------|-----------------|
| Syntax   | Command         | :TRIGger:MANUal |
| Example  | :TRIGger:MANUal |                 |

## 5.8 Trigger Setting Examples

The following are examples of the trigger settings.

| Purpose  | Reference<br>(Table below) |
|--|----------------------------|
| Acquire data since the <b>START</b> command is executed until the <b>STOP</b> command is executed.                     | No. 1                      |
| Acquire 1-minute data one time after the <b>START</b> command is executed.   | No. 2                      |
| Acquire a series of 1-minute data for 60 minutes after the <b>START</b> command is executed.                           | No. 3                      |
| Acquire data since the <b>START</b> command is executed until the measurement temperature in CH1 exceeds 500°C.        | No. 4                      |
| Acquire data once the measurement temperature in CH1 exceeds 500°C until the <b>STOP</b> command is executed.          | No. 5                      |
| Acquire data once the measurement temperature in CH1 exceeds 500°C until the temperature falls below 300°C.            | No. 6                      |
| Acquire data repeatedly once the measurement temperature in CH1 exceeds 500°C until the temperature falls below 300°C. | No. 7                      |
| Acquire data for 1 minute after the measurement temperature in CH1 exceeds 500°C.                                      | No. 8                      |
| Acquire data for 1 minute before and after the measurement temperature in CH1 exceeds 500°C.                           | No. 9                      |
| Acquire data from 2023-6-17 9:00 to 17:00.   | No. 10                     |
| Acquire 24-hour data daily for 1 month starting from 2023-6-17 9:00.   | No. 11                     |
| Acquire data from 9:00 to 17:00 daily for 1 month starting from 2023-6-17.   | No. 12                     |
| Acquire 1-hour data at 9:00, 15:00, 21:00, and 3:00 for 1 month starting from 2023-6-17.                               | No. 13                     |

| No. | Measurement start      | Measurement stop        | Recording start      | Recording stop               | Others                   |
|-----|------------------------|-------------------------|----------------------|------------------------------|--------------------------|
| 1   | Manual                 | Manual                  | –                    | –                            | –                        |
| 2   | Manual                 | Manual                  | –                    | Time specification: 1 minute | –                        |
| 3   | Manual                 | Manual                  | –                    | Time specification: 1 hour   | File splitting: 1 minute |
| 4   | Manual                 | Manual                  | –                    | Stop trigger ↑500°C          | –                        |
| 5   | Manual                 | Manual                  | Start trigger ↑500°C | –                            | –                        |
| 6   | Manual                 | Manual                  | Start trigger ↑500°C | Stop trigger ↓300°C          | –                        |
| 7   | Manual                 | Manual                  | Same as above        | Same as above                | Repetitive recording     |
| 8   | Manual                 | Manual                  | Start trigger ↑500°C | Time specification: 1 minute | –                        |
| 9   | Manual                 | Manual                  | Same as above        | Same as above                | Pre-trigger: 1 minute    |
| 10  | Time<br>2023-6-17 9:00 | Time<br>2023-6-17 17:00 | –                    | –                            | –                        |
| 11  | Time<br>2023-6-17 9:00 | Time<br>2023-7-17 9:00  | –                    | –                            | File splitting: 1 day    |

Trigger Setting Examples

| No. | Measurement start      | Measurement stop       | Recording start              | Recording stop                | Others               |
|-----|------------------------|------------------------|------------------------------|-------------------------------|----------------------|
| 12  | Time<br>2023-6-17 9:00 | Time<br>2023-7-17 9:00 | Interval trigger: 1 day      | Time specification:<br>8 hour | Repetitive recording |
| 13  | Time<br>2023-6-17 9:00 | Time<br>2023-7-17 9:00 | Interval trigger: 6<br>hours | Time specification:<br>1 hour | Repetitive recording |

# 6

# Saving and Loading Data

The measurement conditions of the instrument and the waveform data can be stored on SD memory cards and USB drives.

### IMPORTANT

The operation is guaranteed only for the optional SD memory cards and USB drives. The operation of storage media other than the optional parts is not guaranteed.

## 6.1 Savable and Loadable Data

When data are saved on an SD memory card or USB drive, folders are created in **[HIOKI] > [LR8100]**.

The files are saved in the created folders as shown in the figure below.

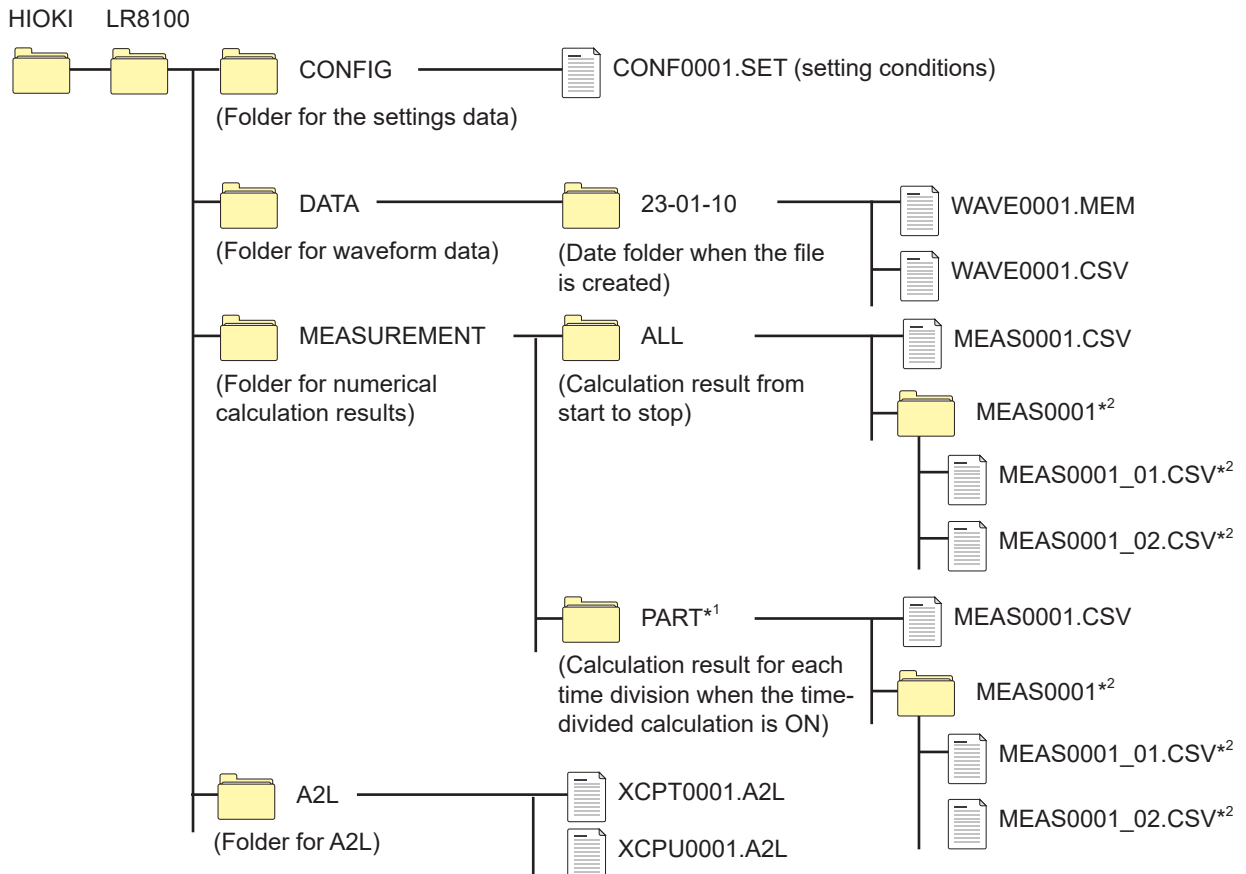

\*1: When the calculation period is set to divided or divided on time, the **[PART]** folder is added. The calculation result from start to stop is stored in **[ALL]**, while the calculation result for each division is stored in **[PART]**.

\*2: Created if the saving settings are configured to Individual calc (separate file for each calculation).

## When a file is saved without specifying a file name

The file is named as follows.

|  |
|--|
| • Automatically saved waveform data: AUTO****.xxx                |
| • Automatically saved numerical calculation result: AUTO****.xxx |
| • Manually saved setting data: CONF****.SET                      |
| • Manually saved waveform data: WAVE****.xxx                     |
| • Manually saved numerical calculation result: MEAS****.xxx      |
| • Manually saved A2L data (for LAN1): XCPT****.A2L               |
| • Manually saved A2L data (for LAN2): XCPU****.A2L               |

[\*\*\*\*] represents a number (0001 to 9999).

[.xxx] represents an extension (.MEM, .CSV, .TXT).

✓: Possible, –: Impossible

| Type                          | Format             | Folder name                                    | File name* <sup>4</sup><br>(automatically numbered starting from 1) | Save      |        | Load       |                  |
|-------------------------------|--------------------|--|---|-----------|--------|------------|------------------|
|                               |                    |  |   | Automatic | Manual | Instrument | PC               |
| Setting condition             | Binary             | CONFIG   | CONF0001.SET  | –         | ✓      | ✓          | –                |
| Waveform data* <sup>1</sup>   | Binary             | DATA¥(Date)* <sup>3</sup><br>Example: 23-01-10 | AUTO0001.MEM<br>WAVE0001.MEM  | ✓         | ✓      | –          | ✓                |
|                               | Text* <sup>2</sup> |  | AUTO0001.CSV<br>WAVE0001.CSV * <sup>5</sup>                         | ✓         | ✓      | –          | ✓                |
|                               | MDF                |  | AUTO0001.MF4  | ✓         | ✓      | –          | ✓* <sup>7</sup>  |
| Numerical calculation results | Text* <sup>2</sup> | MEASUREMENT                                    | AUTO0001.CSV<br>MEAS0001.CSV * <sup>6</sup>                         | ✓         | ✓      | –          | ✓                |
| CAN setting* <sup>8</sup>     | Binary             | –  | ****.CES  | –         | –      | ✓          | ✓* <sup>9</sup>  |
| A2L file* <sup>10</sup>       | –                  | A2L  | XCPT0001.A2L<br>XCPU0001.A2L  | –         | ✓      | –          | ✓* <sup>11</sup> |

\*1: To load the waveform data with the Logger Utility, save the data in the binary format. A part of the setting conditions during the measurement is saved with the waveform data.

When the waveform data after scaling conversion is saved in the binary format, the waveform before the scaling conversion and the scaling settings are recorded. When the waveform data are loaded, the waveform after scaling conversion is displayed. The waveform before the conversion can be displayed by setting the scaling to OFF.

\*2: If the CSV data are loaded with a spreadsheet software, there is a limit to the number of lines that can be loaded at one time.

\*3: Under the **[DATA]** folder, date folders (Year-Month-Day) are automatically created. If the number of files in a folder exceeds 1000, a new folder is created.

Example: 23-01-10\_0000

\*4: For the name of files saved manually, see “14.5 File Name” (p. 325).

\*5: If the delimiter is other than **[COMMA]**, the extension is **[.TXT]**. (p. 172)

\*6: If the Individual calc (separate file for each calculation) is set, “\_ calculation number” is attached as **[MEAS0001\_1.CSV]** and **[MEAS0001\_2.CSV]**.

\*7: Requires commercial software that can load MDF.

\*8: This file is created with the PC application (CAN Editor) to be loaded with the instrument.



\*9: Requires the PC application (CAN Editor).

\*10: This file is saved with the instrument to be loaded with a third-party PC application.

\*11: Requires measurement/compatible software for ECU.



#### Number of files

It is recommended that the number of files saved in one folder should be 1000 or less. Although more than 1000 files can be saved, it takes a longer time for saving as the number of files increase.

In the auto-save operation, if the number of the files in the folder exceeds 1000, a folder is created and the destination folder is switched automatically.

## Preparations and settings in case of power failure

### CAUTION



#### ■ Do not use a damaged medium.

The file completion processing may not end within the expected time, damaging the file.

If the power supply is shut down during the measurement, the measurement data cannot be retained. If measurement is performed for a long time, the following preparations and settings are recommended.

- Set the saving format for the waveform data in the auto-save operation.  
While the measurement is performed, the waveform data are saved on an SD memory card or USB drive.  
See “6.3 Saving Data” (p. 163).



It is recommended that you set **[BIN]** (binary format) for the auto-save operation. Files saved with the **[CSV]** (text format) setting cannot be loaded with the instrument or Logger Utility. Binary data (MEM file) saved with the **[BIN]** setting can be converted to the text format using Logger Utility.

## 6.2 Formatting Media

Format an SD memory card and USB drive before the first use.

| Query  |   |   |
|--|---|---|
| Syntax   | Query   | :MEDIa:SD:FORMat?<br>:MEDIa:USB:FORMat? |
|  | Response  | A\$                                     |
| Example  | :MEDIa:SD:FORMat?<br>(Response) :MEDIa:SD:FORMat? SUCCESS (When the header is ON) |   |
| Parameter  |   |   |
| A\$ = FAIL, SUCCESS<br>Formats media and returns the result. |   |   |
| FAIL   | Format has failed.  |   |
| SUCCESS  | Format has succeeded.   |   |

### IMPORTANT

All data on the medium will be deleted.

### CAUTION

- **Back up important data and store it in a safe place.**



SD memory cards and USB drives have a service life because flash memory is used. They lose the ability to store and load data after extended or frequent use. If you encounter this issue, purchase a new drive. Hioki is not liable for data stored on SD memory cards and USB drives, regardless of the nature or cause of the accident or damage involved.

- **When formatting an SD memory card or USB drive with a PC, select the FAT/FAT32.**

The media formatted to other formats (NTFS, etc.) cannot be recognized with the instrument.

### IMPORTANT

Use the instrument to format new SD memory cards and USB drive before use. If the media are formatted with a PC, the realtime saving may not be completed in time.

## 6.3 Saving Data

There are two ways to save data as follows.

To save data automatically during the measurement

To execute saving using the command

### Auto-save operation

### Manual save operation

Configure the settings before starting the measurement.

The measurement data is saved as soon as the measurement is performed.  
The calculation results are saved when the measurement is stopped.  
(p. 164)

Set the contents to be saved in advance.

When the **SAVE** command is executed, the specified contents are saved.  
(p. 173)

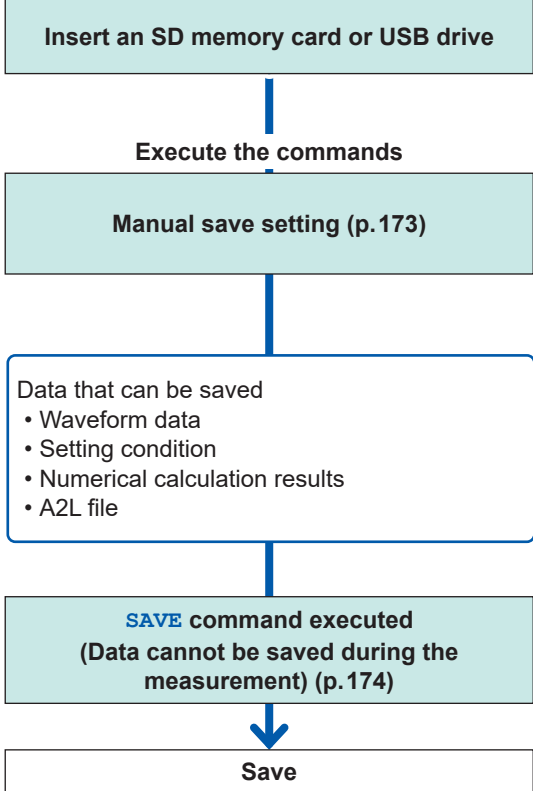
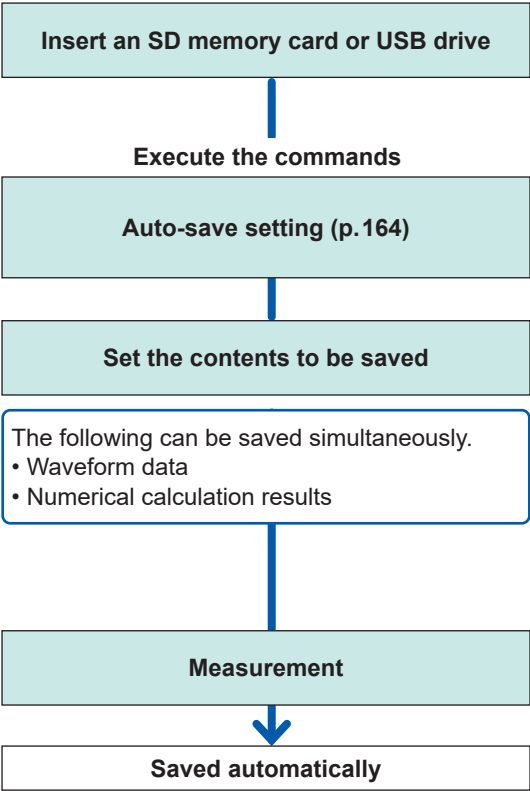

## Auto save (Realtime save)

While the measurement is performed, the waveform data can be saved (realtime save) on a medium (SD memory card or USB drive).

The numerical calculation results can also be saved on the medium automatically.

It is also possible to automatically save both the waveform data and the numerical calculation results.

The following measurement data can be saved automatically.

| Content to be saved           | Parameter     | File extension           | Description   |
|-------------------------------|---------------|--------------------------|---|
| Waveform data                 | Binary format | .MEM                     | The waveform data are saved in the dedicated format (binary format) for the instrument. It is recommended that the binary format (MEM) is set normally.                                       |
|                               | Text format   | .CSV, .TXT* <sup>1</sup> | The waveform data are saved in the text format. The files can be loaded with spreadsheet software, but cannot be loaded with the Logger Utility.  |
|                               | MDF format    | .MF4                     | The waveform data are saved in the MDF (Ver. 4) format. The files can be loaded on a PC with a waveform viewer supporting the MDF format. The files cannot be loaded with the Logger Utility. |
| Numerical calculation results | Text format   | .CSV, .TXT* <sup>1</sup> | The results of the numerical calculation are saved after measurement is stopped.  |

\*1: If the delimiter in the text format is other than **[COMMA]**, the extension is **[.TXT]**.

### Limitation of the auto-save operation for the binary and text formats.

The auto-save operation has the following limitations for the saving format, recording interval, and number of channels used.

| Saving format | Recording interval | Channels used                      |
|---------------|--------------------|------------------------------------|
| MEM, MDF      | 5 ms or more       | No limit                           |
| CSV           | 5 ms               | Cannot set the auto-save operation |
|               | 10 ms              | Maximum of 30 channels             |
|               | 20 ms              | Maximum of 60 channels             |
|               | 50 ms              | Maximum of 150 channels            |
|               | 100 ms or more     | No limit                           |

#### IMPORTANT

The operation is guaranteed only for the optional SD memory cards and USB drives. The operation of storage media other than the optional parts is not guaranteed.

## 1 Specify the file name when saving.

Number "0001" is attached to the end of the file name entered. The number is incremented by 1 starting from the next file name.

Example: If ABC is specified and the file is saved in the binary format

ABC0001.MEM, ABC0002.MEM, ABC0003.MEM, ...

Example: If ABC100 is specified and the file is saved in the binary format

ABC1000001.MEM, ABC1000002.MEM, ABC1000003.MEM, ...

If no file name is specified, the file is named automatically.

See "When a file is saved without specifying a file name" (p. 160).

| Settings   |  |                           |
|--|--|---------------------------|
| Syntax   | Command  | :CONFigure:FILENAME "A\$" |
| Example  | :CONFigure:FILENAME "ABC"  |                           |
| Query  |  |                           |
| Syntax   | Query  | :CONFigure:FILENAME?      |
|  | Response   | A\$                       |
| Example  | :CONFigure:FILENAME?<br>(Response) :CONFIGURE:FILENAME "ABC" (When the header is ON) |                           |
| Parameter  |  |                           |
| A\$ = File name (up to 4 double-byte characters or 8 single-byte characters) |  |                           |

## 2 Set whether or not to attach a title comment to the file name.

When the parameter is set to ON, the file is named as follows.

Set file name\_title comment.MEM

| Settings                     |   |                           |
|------------------------------|---|---------------------------|
| Syntax                       | Command   | :CONFigure:ADDComment A\$ |
| Example                      | :CONFigure:ADDComment ON  |                           |
| Query                        |   |                           |
| Syntax                       | Query   | :CONFigure:ADDComment?    |
|                              | Response  | A\$                       |
| Example                      | :CONFigure:ADDComment?<br>(Response) :CONFIGURE:ADDCOMMENT ON (When the header is ON) |                           |
| Parameter                    |   |                           |
| A\$ = OFF, ON                |   |                           |
| OFF <input type="checkbox"/> | No title comment is attached (serial number is attached automatically).               |                           |
| ON <input type="checkbox"/>  | A title comment is attached.  |                           |

### 3 Set whether or not to attach the date and time to the file name.

When the parameter is set to ON, the file is named as follows.

Input file name\_230324\_235959\_0001.MEM (when the trigger is activated at 2023/03/24 23:59:59)

| Settings                     |   |                        |
|------------------------------|---|------------------------|
| Syntax                       | Command   | :CONFigure:ADDDate A\$ |
| Example                      | :CONFigure:ADDDate ON   |                        |
| Query                        |   |                        |
| Syntax                       | Query   | :CONFigure:ADDDate?    |
|                              | Response  | A\$                    |
| Example                      | :CONFigure:ADDDate?<br>(Response) :CONFIGURE:ADDDATE ON (When the header is ON) |                        |
| Parameter                    |   |                        |
| A\$ = OFF, ON                |   |                        |
| OFF <input type="checkbox"/> | No trigger date is attached (serial number is attached automatically).          |                        |
| ON <input type="checkbox"/>  | The trigger date is attached.   |                        |

### 4 Set the medium to save files preferentially.

When an SD memory card and USB drive are inserted, files are saved on the specified medium. If the specified medium is not inserted, files are saved on the other medium.

| Settings                     |   |                        |
|------------------------------|---|------------------------|
| Syntax                       | Command   | :CONFigure:SAVEPri A\$ |
| Example                      | :CONFigure:SAVEPri SD   |                        |
| Query                        |   |                        |
| Syntax                       | Query   | :CONFigure:SAVEPri?    |
|                              | Response  | A\$                    |
| Example                      | :CONFigure:SAVEPri?<br>(Response) :CONFIGURE:SAVEPRI SD (When the header is ON) |                        |
| Parameter                    |   |                        |
| A\$ = SD, USB                |   |                        |
| SD <input type="checkbox"/>  | SD memory card  |                        |
| USB <input type="checkbox"/> | USB drive   |                        |

## 5 Set the saving format for the auto-save operation.

### (1) Set all settings at once.

| Settings   |   |                               |
|--|---|-------------------------------|
| Syntax   | Command   | :CONFigure:ATSAve A\$(",B\$") |
| Example  | :CONFigure:ATSAve BIN,"AUTO"  |                               |
| Query  |   |                               |
| Syntax   | Query   | :CONFigure:ATSAve?            |
|  | Response  | A\$(",B\$")                   |
| Example  | :CONFigure:ATSAve?<br>(Response) :CONFIGURE:ATSAVE BIN,"AUTO" (When the header is ON) |                               |
| Parameter  |   |                               |
| A\$ = OFF, BIN, CSV, MF4, MEAS, BIN_MEAS, CSV_MEAS, MF4_MEAS<br>B\$ = File name (up to 4 double-byte characters or 8 single-byte characters, A\$ = Omitted when the setting is OFF)  |   |                               |
|  | Waveform data   | Numerical calculation results |
| OFF <input type="checkbox"/>   | Disables saving of data.  | Disables saving of data.      |
| BIN  | Saves in the binary format.   | Disables saving of data.      |
| CSV  | Saves in the text format.   | Disables saving of data.      |
| MF4  | Saves in the MDF4 format.   | Disables saving of data.      |
| MEAS   | Disables saving of data.  | Saves in the text format.     |
| BIN_MEAS   | Saves in the binary format.   | Saves in the text format.     |
| CSV_MEAS   | Saves in the text format.   | Saves in the text format.     |
| MF4_MEAS   | Saves in the MDF4 format.   | Saves in the text format.     |
| The waveform data saving format can also be set using the :SAVEWave command.<br>The saving format of the numerical calculation result can also be set using the :SAVECalc command.<br>The file name can also be set using the :FILENAME command. |   |                               |

### (2) Set the saving format for the waveform data.

| Settings                     |  |                         |
|------------------------------|--|-------------------------|
| Syntax                       | Command  | :CONFigure:SAVEWave A\$ |
| Example                      | :CONFigure:SAVEWave BIN  |                         |
| Query                        |  |                         |
| Syntax                       | Query  | :CONFigure:SAVEWave?    |
|                              | Response   | A\$                     |
| Example                      | :CONFigure:SAVEWave?<br>(Response) :CONFIGURE:SAVEWAVE BIN (When the header is ON) |                         |
| Parameter                    |  |                         |
| A\$ = OFF, BIN, CSV, MF4     |  |                         |
| OFF <input type="checkbox"/> | Disables the auto-save operation.  |                         |
| BIN                          | Saves in the binary format. A file is created with extension .MEM.                 |                         |
| CSV                          | Saves in the text format.  |                         |
| MF4                          | Saves in the MDF4 format.  |                         |

(When the saving format is set to CSV)

**Set whether or not to perform the downsampling operation.**

| Settings   |  |                      |
|--|--|----------------------|
| Syntax   | Command  | :CONFigure:THINOut A |
| Example  | :CONFigure:THINOut 1000  |                      |
| Query  |  |                      |
| Syntax   | Query  | :CONFigure:THINOut?  |
|  | Response   | A<NR1>               |
| Example  | :CONFigure:THINOut?<br>(Response) :CONFIGURE:THINOUT 1000 (When the header is ON)                                  |                      |
| Parameter  |  |                      |
| A = 1 (OFF) to 100000*1  |  |                      |
| 1 <input type="checkbox"/>                                     | Disables the downsampling operation.   |                      |
| 2 to 100000  | Decreases the data size to be saved.<br>Example: If the parameter is set to 5, 1 out of 5 data points is retained. |                      |
| *1. Input in the format of A<NR1>.<br>See "Data part" (p. 23). |  |                      |

(When 2 or more is set for the downsampling)

**Set the method to downsample the data.**

| Settings                         |   |                         |
|----------------------------------|---|-------------------------|
| Syntax                           | Command   | :CONFigure:THINData A\$ |
| Example                          | :CONFigure:THINData INSTANT   |                         |
| Query                            |   |                         |
| Syntax                           | Query   | :CONFigure:THINData?    |
|                                  | Response  | A\$                     |
| Example                          | :CONFigure:THINData?<br>(Response) :CONFIGURE:THINDATA INSTANT (When the header is ON)  |                         |
| Parameter                        |   |                         |
| A\$ = INSTANT, STATISTICS        |   |                         |
| INSTANT <input type="checkbox"/> | The first data is saved.<br>Example: If the parameter is set to 5, only the first data out of 5 is saved.   |                         |
| STATISTICS                       | The statistical data (maximum, minimum, average, and the first data) is saved.<br>Example: If the parameter is set to 5, the maximum, minimum, and average of 5 data sets and the first data are saved. |                         |



Set the processing method when the instrument runs out of free space on the media during the saving operation. (as needed).

| Settings               |   |                         |
|------------------------|---|-------------------------|
| Syntax                 | Command   | :CONFigure:SAVEMode A\$ |
| Example                | :CONFigure:SAVEMode FILEfull  |                         |
| Query                  |   |                         |
| Syntax                 | Query   | :CONFigure:SAVEMode?    |
|                        | Response  | A\$                     |
| Example                | :CONFigure:SAVEMode?<br>(Response) :CONFIGURE:SAVEMODE FILEFULL (When the header is ON)   |                         |
| Parameter              |   |                         |
| A\$ = FILEfull, REMove |   |                         |
| FILEfull <sup>□</sup>  | Deletion mode in the auto-save operation OFF<br>When the instrument runs short of free space on the destination storage medium, the auto-save operation is stopped.   |                         |
| REMOve                 | Deletion mode in the auto-save operation ON<br>The oldest waveform file (binary, text) is deleted and the auto-save operation is continued. If no waveform file can be deleted, the save operation is stopped. The numerical calculation results are not deleted. |                         |

Set the timing to divide a folder. (as needed).

The save destination folder can be divided based on the specified period.

Example: If the parameter is set to WEEK

When measurement is started on 2023/03/26 (Sun), 2023/03/20 (Mon) is the starting point of the week.

In this case, the folder created automatically is named "23-03-20".

Example: If the parameter is set to MONTH

When measurement is started on 2023/03/29, 2023/03/01 is the starting point of the month.

In this case, the folder created automatically is named "23-03-01".

| Settings                    |  |                           |
|-----------------------------|--|---------------------------|
| Syntax                      | Command  | :CONFigure:AUTOFolder A\$ |
| Example                     | :CONFigure:AUTOFolder DAY  |                           |
| Query                       |  |                           |
| Syntax                      | Query  | :CONFigure:AUTOFolder?    |
|                             | Response   | A\$                       |
| Example                     | :CONFigure:AUTOFolder?<br>(Response) :CONFIGURE:AUTOFOLDER DAY (When the header is ON) |                           |
| Parameter                   |  |                           |
| A\$ = OFF, DAY, WEEK, MONTH |  |                           |
| OFF <sup>□</sup>            | Division disabled  |                           |
| DAY                         | 1 day  |                           |
| WEEK                        | 1 week   |                           |
| MONTH                       | 1 month  |                           |

When an external sampling is used, only OFF (Disable) can be set.

**Set the division method (as needed).**

The save destination file can be divided based on the specified time.  
When an external sampling is used, file splitting cannot be performed.

| Settings                        |  |                         |
|---------------------------------|--|-------------------------|
| Syntax                          | Command  | :CONFigure:SAVEKind A\$ |
| Example                         | :CONFigure:SAVEKind NORMAl   |                         |
| Query                           |  |                         |
| Syntax                          | Query  | :CONFigure:SAVEKind?    |
|                                 | Response   | A\$                     |
| Example                         | :CONFigure:SAVEKind?<br>(Response) :CONFIGURE:SAVEKIND NORMAL (When the header is ON)  |                         |
| Parameter                       |  |                         |
| A\$ = NORMAl, DIVide, REGUlarly |  |                         |
| NORMAl <sup>□</sup>             | Division disabled<br>One set of recorded data is saved in one file. However, the file is divided automatically if the file size has exceeded 1 GB.   |                         |
| DIVide                          | Division enabled<br>The data is divided and the save destination file is switched to another file every time after the specified time elapses. However, if the file size has exceeded 1 GB, the file is divided even when the division time has not elapsed.   |                         |
| REGUlarly                       | Divided on time<br>Set the reference time. The save destination file is switched to another file every time after the division time has elapsed starting from the reference time.<br>When the recording is started, the measurement start is kept on standby until the recording interval is synchronized with the reference time. |                         |

(When DIVide is selected for the file splitting)

**Set the period to execute the file splitting.**

| Settings            |   |                                   |
|---------------------|---|-----------------------------------|
| Syntax              | Command   | :CONFigure:SAVELen day, hour, min |
| Example             | :CONFigure:SAVELen 0, 0, 10   |                                   |
| Query               |   |                                   |
| Syntax              | Query   | :CONFigure:SAVELen?               |
|                     | Response  | day<NR1>, hour<NR1>, min<NR1>     |
| Example             | :CONFigure:SAVELen?<br>(Response) :CONFIGURE:SAVELEN 0, 0, 10 (When the header is ON) |                                   |
| Parameter           |   |                                   |
| day                 | 0 to 30 (days)  |                                   |
| hour                | 0 to 23 (hours)   |                                   |
| min                 | 0 to 59 (minutes)   |                                   |
| Minimum of 1 minute |   |                                   |

(When REGULARly is selected for the file splitting)

Set the time that serves as a reference for dividing a file.

| Settings  |  |                             |
|-----------|--|-----------------------------|
| Syntax    | Command  | :CONFigure:SAVEReg hour,min |
| Example   | :CONFigure:SAVEReg 0,0   |                             |
| Query     |  |                             |
| Example   | :CONFigure:SAVEReg?<br>(Response) :CONFIGURE:SAVEREG 0,0 (When the header is ON) |                             |
| Parameter |  |                             |
| hour      | 0 to 23 (hours)  |                             |
| min       | 0 to 59 (minutes)  |                             |

Set the period to divide a file.

| Settings   |  |                       |
|--|--|-----------------------|
| Syntax   | Command  | :CONFigure:SAVETime A |
| Example  | :CONFigure:SAVETime 1  |                       |
| Query  |  |                       |
| Syntax   | Query  | :CONFigure:SAVETime?  |
|  | Response   | A<NR1>                |
| Example  | :CONFigure:SAVETime?<br>(Response) :CONFIGURE:SAVETIME 1 (When the header is ON) |                       |
| Parameter  |  |                       |
| A = 1, 2, 5, 10, 15, 20, 30, 60 (1 hour), 120 (2 hours), 180 (3 hours), 240 (4 hours), 360 (6 hours), 480 (8 hours), 720 (12 hours), 1440 (1 day) (unit min) |  |                       |

The instrument may be in the waiting status for the reference time, depending on the recording interval and start time. Recording starts when the reference time has arrived.

Example when the recording interval is 1 minute

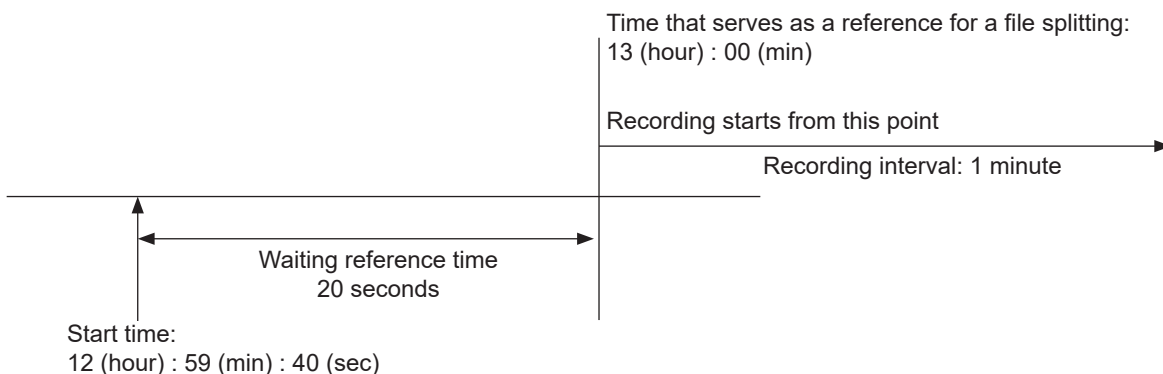

**6 Set the saving format of numerical calculation results for the auto-save operation.**

| Settings                     |  |                         |
|------------------------------|--|-------------------------|
| Syntax                       | Command  | :CONFigure:SAVECalc A\$ |
| Example                      | :CONFigure:SAVECalc CSV  |                         |
| Query                        |  |                         |
| Syntax                       | Query  | :CONFigure:SAVECalc?    |
|                              | Response   | A\$                     |
| Example                      | :CONFigure:SAVECalc?<br>(Response) :CONFIGURE:SAVECALC CSV (When the header is ON) |                         |
| Parameter                    |  |                         |
| A\$ = OFF, CSV               |  |                         |
| OFF <input type="checkbox"/> | Disables the auto-save operation.  |                         |
| CSV                          | Saves data in the text format.   |                         |

**Set whether or not to divide the file to be saved. (as needed).**

| Settings                     |   |                          |
|------------------------------|---|--------------------------|
| Syntax                       | Command   | :CALCulate:MEAS:FILE A\$ |
| Example                      | :CALCulate:MEAS:FILE ON   |                          |
| Query                        |   |                          |
| Syntax                       | Query   | :CALCulate:MEAS:FILE?    |
|                              | Response  | A\$                      |
| Example                      | :CALCulate:MEAS:FILE?<br>(Response) :CALCULATE:MEAS:FILE ON (When the header is ON)   |                          |
| Parameter                    |   |                          |
| A\$ = OFF, ON                |   |                          |
| OFF <input type="checkbox"/> | Single file (all calculations in one file)<br>The results of all numerical calculations are saved in one file.  |                          |
| ON                           | Individual calc (separate file for each calculation)<br>In addition to a file summarizing all calculations, a separate file is created for each calculation item. For the file for each calculation item, the calculation number is attached to the end of the file name.<br>Example: The file name for calculation No. 5 is "AUTO0001_05.CSV". |                          |

**Select whether or not to divide the numerical calculation.**

This setting is the same as the time-divided calculation of the numerical calculation. See "Setting the numerical calculations" (p. 210).

## Manual save operation

Data can be saved using the communication commands.

### IMPORTANT

- Data cannot be saved during the measurement.
- Only the data recorded on the internal buffer memory (final 512 MB) can be saved. To save data exceeding 512 MB, use the auto-save operation (realtime save). (p.164)

The following six types of data can be saved.

- Waveform data (binary format)
- Waveform data (text format)
- Waveform data (MDF format)
- Preset data
- A2L preset data (LAN1 or LAN2) \*1
- Numerical calculation results

\*1. Saves the setting conditions used by measurement/compatible software for ECU.  
See “12.5 Sending Measurement Data Using XCP on Ethernet” (p. 277).

### 1 Specify the file name when saving.

If a value is not entered at the end of the file name, the number “0001” is attached to the end. The number is incremented by 1 starting from the next file name.

Example: If ABC is specified and the file is saved in the binary format  
ABC0001.MEM, ABC0002.MEM, ABC0003.MEM, ...

If the file name has a number attached at its end, the number is incremented by 1.

Example: If ABC100 is specified and the file is saved in the binary format  
ABC101.MEM, ABC102.MEM, ABC103.MEM, ...

| Settings   |          |   |
|--|----------|---|
| Syntax   | Command  | :SYSTem:FILEName "A\$"                                    |
| Example  |          | :SYSTem:FILEName "MANUAL"                                 |
| Query  |          |   |
| Syntax   | Query    | :SYSTem:FILEName?   |
|  | Response | :A\$  |
| Example  |          | :SYSTem:FILEName?<br>(Response) :SYSTEM:FILENAME "MANUAL" |
| Parameter  |          |   |
| A\$ = Character string of file name (up to 4 double-byte characters or 8 single-byte characters) |          |   |

If no file name is specified, the file is named automatically.  
See “When a file is saved without specifying a file name” (p. 160).

**(When the waveform data are saved)**

Set whether or not to attach a title comment to the file name.

| Settings                     |  |                        |
|------------------------------|--|------------------------|
| Syntax                       | Command  | :SYSTem:ADDComment A\$ |
| Example                      | :SYSTem:ADDComment ON  |                        |
| Query                        |  |                        |
| Syntax                       | Query  | :SYSTem:ADDComment?    |
|                              | Response   | A\$                    |
| Example                      | :SYSTem:ADDComment?<br>(Response) :SYSTEM:ADDCOMMENT ON  |                        |
| Parameter                    |  |                        |
| A\$ = OFF, ON                |  |                        |
| OFF <input type="checkbox"/> | No title comment is attached to the file name of waveform data.  |                        |
| ON <input type="checkbox"/>  | A title comment is attached to the file name of waveform data.<br>When the title comment is LOGGER, the file is named as follows.<br>File name specified with :SYSTem:FILENAME_LOGGER_0001.MEM |                        |

**Set whether or not to attach time to the file name.**

When the parameter is set to ON, the file is named as follows.

Input file name \_230324\_235959\_0001.MEM (when the trigger is activated at 2023/03/24 23:59:59)

| Settings                     |   |                     |
|------------------------------|---|---------------------|
| Syntax                       | Command   | :SYSTem:ADDDate A\$ |
| Example                      | :SYSTem:ADDDate ON  |                     |
| Query                        |   |                     |
| Syntax                       | Query   | :SYSTem:ADDDate?    |
|                              | Response  | A\$                 |
| Example                      | :SYSTem:ADDDate?<br>(Response) :SYSTEM:ADDDATE ON (When the header is ON) |                     |
| Parameter                    |   |                     |
| A\$ = OFF, ON                |   |                     |
| OFF <input type="checkbox"/> | No trigger date is attached.  |                     |
| ON <input type="checkbox"/>  | The trigger date is attached.   |                     |

**(When the waveform data are saved in the text format)**

Set whether or not to perform the downsampling operation.

| Settings  |  |                   |
|---|--|-------------------|
| Syntax  | Command  | :SYSTem:THINOut A |
| Example   | :SYSTem:THINOut 5                                |                   |
| Query   |  |                   |
| Syntax  | Query  | :SYSTem:THINOut?  |
|   | Response   | A<NR1>            |
| Example   | :SYSTem:THINOut?<br>(Response) :SYSTEM:THINOUT 5 |                   |
| Parameter   |  |                   |
| A = 1 (OFF) to 100000<br>If the parameter is set to 1, the downsampling is disabled.<br>If the parameter is set to 5, 1 out of 5 data points is retained. |  |                   |

**(When other than OFF is set for the downsampling)**

Set the method to downsample the data.

| Settings                                    |   |                      |
|---|---|----------------------|
| Syntax                                      | Command   | :SYSTem:THINData A\$ |
| Example                                     | :SYSTem:THINData INSTANT  |                      |
| Query                                       |   |                      |
| Syntax                                      | Query   | :SYSTem:THINData?    |
|   | Response  | A\$                  |
| Example                                     | :SYSTem:THINData?<br>(Response) :SYSTEM:THINDATA INSTANT  |                      |
| Parameter                                   |   |                      |
| A\$ = INSTANT, STATISTICS                   |   |                      |
| INSTANT <input checked="" type="checkbox"/> | The first data is saved.<br>Example: If the parameter is set to 5, only the first data out of 5 is saved.   |                      |
| STATISTICS                                  | The statistical data (maximum, minimum, average, and the first data) is saved.<br>Example: If the parameter is set to 5, the maximum, minimum, and average of 5 data sets and the first data are saved. |                      |

**(When the numerical calculation results are saved)**

Configure the settings for dividing the file to be saved.

| Settings                                |   |                       |
|---|---|-----------------------|
| Syntax                                  | Command   | :SYSTem:CALCSplit A\$ |
| Example                                 | :SYSTem:CALCSplit ON  |                       |
| Query                                   |   |                       |
| Syntax                                  | Query   | :SYSTem:CALCSplit?    |
|   | Response  | A\$                   |
| Example                                 | :SYSTem:CALCSplit?<br>(Response) :SYSTEM:CALCSPLIT ON               |                       |
| Parameter                               |   |                       |
| A\$ = OFF, ON                           |   |                       |
| OFF <input checked="" type="checkbox"/> | Saves the results of the numerical calculation in one file.         |                       |
| ON                                      | Saves the results of each numerical calculation in a separate file. |                       |

## 2 Execute the save operation.

If the file size of waveform data exceeds 1 GB, the file is automatically divided and saved by approx. 1 GB.

See “14.5 File Name” (p. 325).

| Settings       |          |  |
|----------------|----------|--|
| <b>Syntax</b>  | Command  | When the waveform data (binary format) are saved<br>:MEDia:SD:SAVE:DATA:MEM<br>:MEDia:USB:SAVE:DATA:MEM<br><br>When the waveform data (text format) are saved<br>:MEDia:SD:SAVE:DATA:CSV<br>:MEDia:USB:SAVE:DATA:CSV<br><br>When the waveform data (MDF format) are saved<br>:MEDia:SD:SAVE:DATA:MF4<br>:MEDia:USB:SAVE:DATA:MF4<br><br>When the preset data are saved<br>:MEDia:SD:SAVE:SET<br>:MEDia:USB:SAVE:SET<br><br>When the A2L preset data are saved (LAN1)<br>:MEDia:SD:SAVE:A2L:LAN1<br>:MEDia:USB:SAVE:A2L:LAN1<br><br>When the A2L preset data are saved (LAN2)<br>:MEDia:SD:SAVE:A2L:LAN2<br>:MEDia:USB:SAVE:A2L:LAN2<br><br>When the numerical calculation results are saved<br>:MEDia:SD:SAVE:CALC:CSV<br>:MEDia:USB:SAVE:CALC:CSV               |
| <b>Example</b> |          | :MEDia:SD:SAVE:DATA:MEM  |
| Query          |          |  |
| <b>Syntax</b>  | Query    | When the waveform data (binary format) are saved<br>:MEDia:SD:SAVE:DATA:MEM?<br>:MEDia:USB:SAVE:DATA:MEM?<br><br>When the waveform data (text format) are saved<br>:MEDia:SD:SAVE:DATA:CSV?<br>:MEDia:USB:SAVE:DATA:CSV?<br><br>When the waveform data (MDF format) are saved<br>:MEDia:SD:SAVE:DATA:MF4?<br>:MEDia:USB:SAVE:DATA:MF4?<br><br>When the preset data are saved<br>:MEDia:SD:SAVE:SET?<br>:MEDia:USB:SAVE:SET?<br><br>When the A2L preset data are saved (LAN1)<br>:MEDia:SD:SAVE:A2L:LAN1?<br>:MEDia:USB:SAVE:A2L:LAN1?<br><br>When the A2L preset data are saved (LAN2)<br>:MEDia:SD:SAVE:A2L:LAN2?<br>:MEDia:USB:SAVE:A2L:LAN2?<br><br>When the numerical calculation results are saved<br>:MEDia:SD:SAVE:CALC:CSV?<br>:MEDia:USB:SAVE:CALC:CSV? |
|                | Response | A\$  |



|   |   |
|---|---|
| <b>Example</b>  | <code>:MEDia:SD:SAVE:DATA:MEM?</code><br>(Response) <code>:MEDIA:SD:SAVE:DATA:MEM? SUCCESS_TEST</code><br>(When the header is ON) |
| <b>Parameter</b>  |   |
| <code>A\$</code> = NONE, EXECUTING, SUCCESS_(File name), FAIL |   |
| <code>NONE</code>   | Saving has not yet been executed.   |
| <code>EXECUTING</code>  | Saving is currently in operation.   |
| <code>SUCCESS_(File name)</code>                              | Saving has succeeded. The name of the saved file is attached at the end.  |
| <code>FAIL</code>   | Saving has failed.  |

**IMPORTANT**

When an SD memory card and USB flash drive are inserted, files are saved on the specified medium.

If the specified medium is not inserted, files are saved on the other medium.

## Common saving settings

### 1 Set the format of text.

#### Set the symbol to be used as the decimal point.

This setting is not initialized. The default value varies depending on the shipping destination.

| Settings            |   |                         |
|---------------------|---|-------------------------|
| Syntax              | Command   | :CONFigure:SAVEDeci A\$ |
| Example             | :CONFigure:SAVEDeci PERIOD  |                         |
| Query               |   |                         |
| Syntax              | Query   | :CONFigure:SAVEDeci?    |
|                     | Response  | A\$                     |
| Example             | :CONFigure:SAVEDeci?<br>(Response) :CONFIGURE:SAVEDECI PERIOD (When the header is ON) |                         |
| Parameter           |   |                         |
| A\$ = PERIOD, COMMA |   |                         |
| PERIOD              | Set a period (.) as the decimal point of numerical values.                            |                         |
| COMMA               | Set a comma (,) as the decimal point of numerical values.                             |                         |

It is impossible to set the decimal point symbol and the delimiter to COMMA simultaneously.

#### Set the symbol to be used for separation.

The delimiter determines the file extension.

This setting is not initialized. The default value varies depending on the shipping destination.

| Settings                      |  |                        |
|-------------------------------|--|------------------------|
| Syntax                        | Command  | :CONFigure:SAVESep A\$ |
| Example                       | :CONFigure:SAVESep COMMA   |                        |
| Query                         |  |                        |
| Syntax                        | Query  | :CONFigure:SAVESep?    |
|                               | Response   | A\$                    |
| Example                       | :CONFigure:SAVESep?<br>(Response) :CONFIGURE:SAVESEP COMMA (When the header is ON) |                        |
| Parameter                     |  |                        |
| A\$ = COMMA, SPACE, TAB, SEMI |  |                        |
| COMMA                         | Set a comma (,) as the delimiter. (extension: .CSV)                                |                        |
| SPACE                         | Set a space as the delimiter. (extension: .TXT)                                    |                        |
| TAB                           | Set a tab as the delimiter. (extension: .TXT)                                      |                        |
| SEMI                          | Set a semicolon (;) as the delimiter. (extension: .TXT)                            |                        |

It is impossible to set the decimal point symbol and the delimiter to COMMA simultaneously.

**Set the format to describe the date.**

This is only enabled when the horizontal (time) axis display setting (p.228) is set to “DATE”.

| Settings  |   |                           |
|---|---|---------------------------|
| Syntax  | Command   | :CONFigure:SAVEFormat A\$ |
| Example   | :CONFigure:SAVEFormat COMMENT   |                           |
| Query   |   |                           |
| Syntax  | Query   | :CONFigure:SAVEFormat?    |
|   | Response  | A\$                       |
| Example   | :CONFigure:SAVEFormat?<br>(Response) :CONFIGURE:SAVEFORMAT COMMENT (When the header is ON)  |                           |
| Parameter   |   |                           |
| A\$ = COMMENT, SPLITMS  |   |                           |
| COMMENT <sup>☐</sup>  | Comment (yy-MM-dd hh:mm:ss.0)<br>The date is output in the format of ' (apostrophe) Year-Month-Day<br>Hour:Minute:Second.Millisecond.<br>Spreadsheet software handles this output as a comment.<br>Example: <b>20-12-01 23:59:59.999</b>  |                           |
| SPLITMS   | Less than 1 second split (yyyy-MM-dd hh:mm:ss + ms)<br>The date is output in the format of " (double quotation) Year-Month-Day<br>Hour:Minute:Second", and the time data less than 1 second (unit: ms) is output<br>separately.<br>Spreadsheet software displays the time data less than 1 second in a separate<br>column.<br>This format is useful when integrating CSV data acquired with different devices using<br>spreadsheet software.<br>Example: <b>2023-03-01 23:59:59,999</b> |                           |
| Depending on the date format and the date delimiter settings in “Language” (p. 226), the following formats<br>can also be selected.<br>The same format as yy-MM-dd hh:mm:ss.0 above |   |                           |
| yy/MM/dd, yy.MM.dd, MM-dd-yy, MM/dd/yy, MM.dd.yy, dd-MM-yy, dd/MM/yy, dd.MM.yy  |   |                           |
| The same format as yyyy-MM-dd hh:mm:ss + ms above   |   |                           |
| yyyy/MM/dd, yyyy.MM.dd, MM-dd-yyyy, MM/dd/yyyy, MM.dd.yyyy, dd-MM-yyyy,<br>dd/MM/yyyy, dd.MM.yyyy   |   |                           |

## 6.4 Loading Data

Setting data saved on the media (SD memory card, USB drive) can be loaded.

The following files can be loaded with the instrument: setting conditions saved with LR8101 or LR8102 and CAN setting file (CES) saved with the PC application (CAN Editor).

The auto-load function for the setting files is available.

See "Auto-setup function" (p. 182).



### To acquire the preset data list saved on a medium

See "Display a list of the files in [\[HIOKI/LR8100/CONFIG\]](#) for each medium." (p. 183).

### 1 Check that the setting conditions can be loaded.

The settings cannot be loaded if the module configuration is different.

| Query   |   |   |
|---|---|---|
| Syntax  | Query   | <code>:MEDia:SD:FINFo:SET? "fname\$"</code><br><code>:MEDia:USB:FINFo:SET? "fname\$"</code> |
|   | Response  | <code>ans\$, modules\$</code>   |
| Example   | <code>:MEDia:SD:FINFo:SET? "CONF0001.SET"</code><br>(Response): <code>MEDIA:SD:FINFo:SET? OK,1300000000</code><br>(When the header is ON) |   |
| Parameter   |   |   |
| <code>fname\$</code> = File name of the setting conditions to be loaded (xxxx.SET)<br><code>ans\$</code> = OK, NG_MODEL, NG_MODULE, BUSY<br><code>modules\$</code> = 0, 1, 3 (module type)  |   |   |
| <code>OK</code>   | The settings can be loaded.   |   |
| <code>NG_MODEL</code>   | The settings cannot be loaded because the setting file is for a different model.*1  |   |
| <code>NG_MODULE</code>  | The settings cannot be loaded because the setting file is for a different module configuration.   |   |
| <code>BUSY</code>   | The information cannot be acquired because file processing is underway.*1   |   |
| *1. In this case, all the digits for the module type are 0.   |   |   |
| <code>module\$ = 0</code>   | No module   |   |
| <code>module\$ = 1</code>   | M7100 Voltage/Temp Module   |   |
| <code>module\$ = 3</code>   | M7102 Voltage/Temp Module   |   |
| The module types are module 1, module 2, and so on, in this order from the left.<br>In the case of 1300000000, module 1 is M7100, module 2 is M7102, and there are no modules for the rest. |   |   |

## 2 Load the setting conditions.

| Settings  |  |   |
|---|--|---|
| Syntax  | Command  | :MEDia:SD:LOAD:SET "fname\$",option<br>:MEDia:USB:LOAD:SET "fname\$",option |
| Example   | :MEDia:SD:LOAD:SET "CONF0001.SET",0  |   |
| Query   |  |   |
| Syntax  | Query  | :MEDia:SD:LOAD:SET?<br>:MEDia:USB:LOAD:SET?                                 |
|   | Response   | A\$   |
| Example   | :MEDia:SD:LOAD:SET?<br>(Response) :MEDIA:SD:LOAD:SET? SUCCESS_LOAD_CONF0001<br>(When the header is ON) |   |
| Parameter   |  |   |
| <b>fname\$</b> = File name of the setting conditions to be loaded (xxxx.SET)<br><b>option</b> = 0 to 3 (Load option)<br><b>A\$</b> = NONE, FILE_NONE, EXECUTING_LOAD_(File name), SUCCESS_LOAD_(File name), FAIL_LOAD_(File name) |  |   |
| <b>NONE</b>   | Loading has not yet been executed.   |   |
| <b>FILE_NONE</b>  | The specified file for loading does not exist.   |   |
| <b>EXECUTING_LOAD_</b><br>(File name)   | Loading is currently in operation.   |   |
| <b>SUCCESS_LOAD_</b> (File name)  | Loading has succeeded. The name of the loaded file is attached at the end.                             |   |
| <b>FAIL_LOAD_</b> (File name)   | Loading has failed.  |   |
| The type of setting to be loaded varies with the specified setting load options.<br>Setting load option   |  |   |
| <b>option = 0</b>   | Measurement settings   |   |
| <b>option = 1</b>   | Measurement settings + External terminal   |   |
| <b>option = 2</b>   | Measurement settings + Communication settings  |   |
| <b>option = 3</b>   | Measurement settings + External terminal + Communication settings                                      |   |

## Auto-setup function

---

The setting file can be automatically loaded when the power is turned ON.

If the setting data is saved with the file name **[STARTUP.SET]** in the folder **[HIOKI] > [LR8100] > [CONFIG]**, the setting file can be automatically loaded when the power is turned ON.

If both the SD memory card and USB drive contain **[STARTUP.SET]**, the setting conditions on the SD memory card is loaded preferentially.

### **IMPORTANT**

The communication settings including the IP address are also loaded.

If the same **[STARTUP.SET]** is used for multiple LR8101 or LR8102, a network failure may occur.

Create **[STARTUP.SET]** for each instrument.

## 6.5 Organizing Data

You can organize the data on an SD memory card or USB drive inserted into the instrument. The following operations can be performed.

- Formatting the SD memory card or USB drive (p. 162)
- Loading files (p. 180)

### Querying the free space on the medium

| Query                     |  |   |
|---------------------------|--|---|
| Syntax                    | Query  | <code>:MEDia:SD:FREE?</code><br><code>:MEDia:USB:FREE?</code> |
|                           | Response   | <code>A&lt;NR1&gt;</code>                                     |
| Example                   | <code>:MEDia:SD:FREE?</code><br>(Response) <code>:MEDIA:SD:FREE 511156224</code> |   |
| Parameter                 |  |   |
| <code>A&lt;NR1&gt;</code> |  |   |

Display a list of the files in `[/HIOKI/LR8100/CONFIG]` for each medium.

| Query   |   |   |
|---|---|---|
| Syntax  | Query   | <code>:MEDia:SD:FLIST:SET?</code><br><code>:MEDia:USB:FLIST:SET?</code> |
|   | Response  | <code>A1\$,A2...</code>   |
| Example   | <code>:MEDia:SD:FLIST:SET?</code><br>(Response) <code>:MEDIA:SD:FLIST:SET CONF0002.SET,CONF0001.SET</code><br>(When the header is ON) |   |
| Parameter   |   |   |
| <code>A\$</code> = File name<br>Up to 100 files can be acquired for the list. |   |   |





# 7

# Alarm (Alarm Output)

Alarm conditions can be set for each measurement channel.

The instrument can be set to sound a buzzer and output alarm signals to external devices when the measurement data satisfies specified conditions.

For example, an alarm can be output if recorded temperature is increased.

The following channels can be set as alarm sources.

Analog, Pulse, Logic, Waveform calculation

The following alarm types can be set: level, window, pattern, slope, and amount of change.

Alarm signals can be output from the external control terminal to external devices.

See "11 External Control (EXT. I/O)" (p.241).

If an alarm condition is satisfied when measurement is started, the alarm is output immediately.

## 7.1 Setting Alarms

### Alarm condition settings that apply to all channels

Set the alarm conditions that apply to all channels.

#### 1 Set the alarm function to ON.

| Settings  |   |                                     |
|---|---|-------------------------------------|
| Syntax  | Command   | <code>:MODuLe:STORe ch\$,A\$</code> |
| Example   | <code>:MODuLe:STORe ALARM,ON</code>   |                                     |
| Query   |   |                                     |
| Syntax  | Query   | <code>:MODuLe:STORe? ch\$</code>    |
|   | Response  | <code>ch\$,A\$</code>               |
| Example   | <code>:MODuLe:STORe? ALARM</code><br>(Response) <code>:MODULE:STORE ALARM,ON</code> (When the header is ON) |                                     |
| Parameter   |   |                                     |
| <code>ch\$</code> = CH1_1 to CH10_30, PLS1, LOG, ALARM, W1 to W30 |   |                                     |
| <code>A\$</code> = OFF, ON  |   |                                     |

## 2 Set the alarm output hold.

| Settings             |  |                 |
|----------------------|--|-----------------|
| Syntax               | Command  | :ALARm:HOLD A\$ |
| Example              | :ALARm:HOLD ON   |                 |
| Query                |  |                 |
| Syntax               | Query  | :ALARm:HOLD?    |
|                      | Response   | A\$             |
| Example              | :ALARm:HOLD?<br>(Response) :ALARm:HOLD ON (When the header is ON)  |                 |
| Parameter            |  |                 |
| A\$ = OFF, ON, CLEAR |  |                 |
| OFF <sup>□</sup>     | When the alarm condition is no longer satisfied, the alarm output is stopped. Select this setting to output the alarm only when the alarm condition is satisfied.  |                 |
| ON                   | <p>Once an alarm is output, the alarm output is held until the alarm is canceled manually or the measurement is stopped. Select this setting to hold the alarm output even if the alarm condition is no longer satisfied (the normal condition is recovered).</p> <ul style="list-style-type: none"> <li>• If the alarm filter (p. 189) is 0 (OFF)<br/>The alarm hold is applied to the judgment result for the alarm sources to be monitored.<br/>Example: For AND between U1-1 and U1-2<br/>Once the alarm condition of U1-1 is satisfied, the realization of the alarm condition is held. After that, the realization of U1-1 is held even if the alarm condition is no longer satisfied. Therefore, if the alarm condition of U1-2 is satisfied, the alarm is output.</li> <li>• If the alarm filter (p. 189) other than 2 to 1000 (excluding OFF)<br/>The alarm hold is applied to ALM1 to ALM4.<br/>Example: For AND between U1-1 and U1-2<br/>The alarm output is held only when the conditions of U1-1 and U1-2 are satisfied at the same time.</li> </ul> |                 |
| CLEAR                | Cancels the held alarm without stopping the recording.   |                 |

## 3 Set whether or not to sound an alarm buzzer when outputting an alarm.

| Settings      |   |                 |
|---------------|---|-----------------|
| Syntax        | Command   | :ALARm:BEEP A\$ |
| Example       | :ALARm:BEEP ON  |                 |
| Query         |   |                 |
| Syntax        | Query   | :ALARm:BEEP?    |
|               | Response  | A\$             |
| Example       | :ALARm:BEEP?<br>(Response) :ALARm:BEEP ON (When the header is ON) |                 |
| Parameter     |   |                 |
| A\$ = OFF, ON |   |                 |

#### 4 Set whether or not to place an event mark when an alarm is issued.

| Settings      |   |                  |
|---------------|---|------------------|
| Syntax        | Command   | :SYSTem:MARK A\$ |
| Example       | :SYSTem:MARK ON   |                  |
| Query         |   |                  |
| Syntax        | Query   | :SYSTem:MARK?    |
|               | Response  | A\$              |
| Example       | :SYSTem:MARK?<br>(Response) :SYSTEM:MARK ON (When the header is ON) |                  |
| Parameter     |   |                  |
| A\$ = OFF, ON |   |                  |

See “8.3 Placing an Event Mark When an Alarm is Issued” (p. 207).

#### 5 Set the alarm history.

The history of alarms issued during the measurement is saved.

When the trigger is used, the alarm history while the instrument is in the trigger standby state is also saved (it can include the alarm history before the recorded waveform data).

| Settings         |   |                    |
|------------------|---|--------------------|
| Syntax           | Command   | :ALARm:HISTory A\$ |
| Example          | :ALARm:HISTory ON   |                    |
| Query            |   |                    |
| Syntax           | Query   | :ALARm:HISTory?    |
|                  | Response  | A\$                |
| Example          | :ALARm:HISTory?<br>(Response) :ALARM:HISTORY ON (When the header is ON)   |                    |
| Parameter        |   |                    |
| A\$ = OFF, ON    |   |                    |
| OFF <sup>☐</sup> | Alarm numbers 1 to 100 are kept in the history (No. 101 and later are not kept in the history).   |                    |
| ON               | The latest 100 alarms are kept in the history (older alarms are not kept in the history). Alarm numbers up to 999,999 can be kept in the history. |                    |

#### 6 Set the alarm realization condition for each alarm output (ALM1 to ALM4).

| Settings                              |   |                         |
|---------------------------------------|---|-------------------------|
| Syntax                                | Command   | :ALARm:SOURce alm\$,A\$ |
| Example                               | :ALARm:SOURce ALM1,AND  |                         |
| Query                                 |   |                         |
| Syntax                                | Query   | :ALARm:SOURce? alm\$    |
|                                       | Response  | alm\$,A\$               |
| Example                               | :ALARm:SOURce? ALM1<br>(Response) :ALARM:SOURCE ALM1,AND (When the header is ON)                                |                         |
| Parameter                             |   |                         |
| alm\$ = ALM1 to ALM4<br>A\$ = OR, AND |   |                         |
| OR <sup>☐</sup>                       | Logical sum<br>Outputs an alarm when any one of the alarm conditions set for the channels is satisfied.         |                         |
| AND                                   | Logical multiplication<br>Outputs an alarm when all of the alarm conditions set for the channels are satisfied. |                         |

**7 For each alarm output (ALM1 to ALM4), set whether or not to output an alarm when a thermocouple wire break is detected.**

This setting is enabled if the wire break detection setting is set to ON in the input channel settings. See “Temperature (thermocouple) measurement” (p. 96).

An alarm is triggered regardless of other alarm conditions (OR, AND).

| Settings             |   |                       |
|----------------------|---|-----------------------|
| Syntax               | Command   | :ALARm:BURN alm\$,A\$ |
| Example              | :ALARm:BURN ALM1,ON   |                       |
| Query                |   |                       |
| Syntax               | Query   | :ALARm:BURN? alm\$    |
|                      | Response  | alm\$,A\$             |
| Example              | :ALARm:BURN? ALM1<br>(Response) :ALARm:BURN ALM1,ON (When the header is ON) |                       |
| Parameter            |   |                       |
| alm\$ = ALM1 to ALM4 |   |                       |
| A\$ = OFF, ON        |   |                       |

## Settings for each alarm channel

Configure the settings for each of the alarm channels from ALM1 to ALM4.

### 1 Set the data points for the alarm filter.

An alarm is triggered if the alarm status continues for the specified number of data points.

| Settings                            |  |                                    |
|-------------------------------------|--|------------------------------------|
| Syntax                              | Command  | <code>:ALARm:FILTer alm\$,A</code> |
| Example                             | <code>:ALARm:FILTer ALM1,2</code>  |                                    |
| Query                               |  |                                    |
| Syntax                              | Query  | <code>:ALARm:FILTer? alm\$</code>  |
|                                     | Response   | <code>alm\$,A&lt;NR1&gt;</code>    |
| Example                             | <code>:ALARm:FILTer? ALM1</code><br>(Response) <code>:ALARm:FILTer ALM1,2</code> (When the header is ON) |                                    |
| Parameter                           |  |                                    |
| <code>alm\$</code> = ALM1 to ALM4   |  |                                    |
| <code>A</code> = 0 (OFF), 2 to 1000 |  |                                    |

### 2 Set the comment (as needed).

See "(3) Character string data" (p. 24).

| Settings  |   |   |
|---|---|---|
| Syntax  | Command   | <code>:COMMeNt:ALMCH alm\$,"A\$"</code> |
| Example   | <code>:COMMeNt:ALMCH ALM1,"ABCDEFGF"</code>   |   |
| Query   |   |   |
| Syntax  | Query   | <code>:COMMeNt:ALMCH? alm\$</code>      |
|   | Response  | <code>alm\$,"A\$"</code>                |
| Example   | <code>:COMMeNt:ALMCH? ALM1</code><br>(Response) <code>:COMMeNt:ALMCH ALM1,"ABCDEFGF"</code> (When the header is ON) |   |
| Parameter   |   |   |
| <code>alm\$</code> = ALM1 to ALM4   |   |   |
| <code>A\$</code> = Character string of comment (up to 20 double-byte characters or 40 single-byte characters) |   |   |

## Alarm settings for each channel

Set the alarm functions for each channel.

### 1 Set the alarms for ALM1 to ALM4 of each channel to be monitored.

| Alarm type                              | Settings                     |   | Operation | Description   |
|---|------------------------------|---|-----------|---|
| OFF <input checked="" type="checkbox"/> | -                            |   | -         | The alarm function is disabled.   |
| LEVEL                                   | Slope                        | HIGH <input checked="" type="checkbox"/><br>LOW |           | Outputs an alarm when the measurement data is equal to or greater than the specified level.   |
|   | Level                        | Enter a numerical value                         |           |   |
| WINDOW                                  | Direction                    | IN <input checked="" type="checkbox"/><br>OUT   |           | Outputs an alarm when the measurement data is equal to or greater than the lower limit value and is equal to or less than the upper limit value.  |
|   | Upper and lower limit values | Enter a numerical value                         |           | Outputs an alarm when the measurement data is less than the lower limit value or greater than the upper limit value. However, in the case of the pulse channel, an alarm is also output when the measured value is 0, if the upper or lower limit value is 0. |
| SLOPE                                   | Level                        | Enter a numerical value                         |           | Outputs an alarm when the rate of change of the measurement data exceeds the rate of change (level/time) calculated from the setting for a specified time.* 2   |
|   | Time                         | Set a time*1                                    |           |   |

\*1. The time values that can be set are integer multiples of the module's data refresh interval.

\*2. Example of slope

If the level is set to 5°C and the time is set to 5 seconds

1. If the recording interval is 5 seconds

An alarm is triggered if the difference from the previous measured value exceeds 5°C.

Data example: If the value is increased from 20°C to 25.1°C

2. If the recording interval is 1 second

An alarm is triggered if the difference from the previous measured value exceeds 1°C for 5 data points consecutively.

Data example: If the value is increased from 20°C to 21.1°C, 22.2°C, 23.3°C, 24.4°C, and then 25.5°C

| Alarm type | Settings |   | Operation                                 | Description  |
|------------|----------|---|---|--|
| SLOPE2     | Slope    | HIGH <input checked="" type="checkbox"/><br>LOW | <p>Change calculated from the setting</p> | Outputs an alarm when the amount of change within the specified width is equal to or greater or less than the specified level value. |
|            | Level    | Enter a numerical value                         |   |  |
|            | Width    | Set a width in time                             |   |  |

| Settings   |  |   |
|--|--|---|
| Syntax   | Command  | Analog channel alarm<br><code>:ALARM:ANALog:KIND alm\$,ch\$,A\$</code><br>Waveform calculation channel alarm<br><code>:ALARM:CALCulate:KIND alm\$,w\$,A\$</code><br>Pulse channel alarm<br><code>:ALARM:PULSe:KIND alm\$,pls\$,A\$</code> |
| Example  | <code>:ALARM:ANALog:KIND ALM1,CH1_1,LEVEL</code>   |   |
| Query  |  |   |
| Syntax   | Query  | Analog channel alarm<br><code>:ALARM:ANALog:KIND? alm\$,ch\$</code><br>Waveform calculation channel alarm<br><code>:ALARM:CALCulate:KIND? alm\$,w\$</code><br>Pulse channel alarm<br><code>:ALARM:PULSe:KIND? alm\$,pls\$</code>          |
|  | Response   | Analog channel alarm<br><code>alm\$,ch\$,A\$</code><br>Waveform calculation channel alarm<br><code>alm\$,w\$,A\$</code><br>Pulse channel alarm<br><code>alm\$,pls\$,A\$</code>  |
| Example  | <code>:ALARM:ANALog:KIND? ALM1,CH1_1</code><br>(Response) <code>:ALARM:ANALOG:KIND ALM1,CH1_1,LEVEL</code> (When the header is ON) |   |
| Parameter  |  |   |
| <code>alm\$</code> = ALM1 to ALM4<br><code>ch\$</code> = CH1_1 to CH10_30<br><code>w\$</code> = W1 to W30<br><code>pls\$</code> = PLS1<br><code>A\$</code> = OFF, LEVEL, WINDOW, SLOPe, SLOPE2 |  |   |
| <code>OFF</code> <input checked="" type="checkbox"/>   | The alarm function is disabled.  |   |
| <code>LEVEL</code>   | Level  |   |
| <code>WINDOW</code>  | Window   |   |
| <code>SLOPe</code>   | Slope  |   |
| <code>SLOPE2</code>  | Amount of change   |   |
| When an external sampling is used, only "LEVEL" and "WINDOW" can be set.   |  |   |

**If the alarm type is LEVEL**

**(1) Set the slope.**

| Settings   |   |  |
|--|---|--|
| <b>Syntax</b>  | Command   | Analog channel alarm<br><code>:ALARm:ANALog:SLOPe alm\$,ch\$,A\$</code><br>Waveform calculation channel alarm<br><code>:ALARm:CALCulate:SLOPe alm\$,w\$,A\$</code><br>Pulse channel alarm<br><code>:ALARm:PULSe:SLOPe alm\$,pls\$,A\$</code> |
| <b>Example</b>   | <code>:ALARm:ANALog:SLOPe ALM1,CH1_1,HIGH</code>  |  |
| Query  |   |  |
| <b>Syntax</b>  | Query   | Analog channel alarm<br><code>:ALARm:ANALog:SLOPe? alm\$,ch\$</code><br>Waveform calculation channel alarm<br><code>:ALARm:CALCulate:SLOPe? alm\$,w\$</code><br>Pulse channel alarm<br><code>:ALARm:PULSe:SLOPe? alm\$,pls\$</code>          |
|  | Response  | Analog channel alarm<br><code>alm\$,ch\$,A\$</code><br>Waveform calculation channel alarm<br><code>alm\$,w\$,A\$</code><br>Pulse channel alarm<br><code>alm\$,pls\$,A\$</code>   |
| <b>Example</b>   | <code>:ALARm:ANALog:SLOPe? ALM1,CH1_1</code><br>(Response) <code>:ALARm:ANALOG:SLOPE ALM1,CH1_1,HIGH</code> (When the header is ON) |  |
| Parameter  |   |  |
| <code>alm\$</code> = ALM1 to ALM4<br><code>ch\$</code> = CH1_1 to CH10_30<br><code>w\$</code> = W1 to W30<br><code>pls\$</code> = PLS1<br><code>A\$</code> = HIGH, LOW |   |  |
| <code>HIGH</code> <sup>□</sup>   | Outputs an alarm when the measurement data is equal to or greater than the specified level.   |  |
| <code>LOW</code>   | Outputs an alarm when the measurement data is less than the specified level.  |  |



## (2) Set the level.

| Settings   |  |   |
|--|--|---|
| <b>Syntax</b>  | Command  | Analog channel alarm<br>:ALARm:ANALog:LEVEL alm\$,ch\$,A<br>Waveform calculation channel alarm<br>:ALARm:CALCulate:LEVEL alm\$,w\$,A<br>Pulse channel alarm<br>:ALARm:PULSe:LEVEL alm\$,pls\$,A   |
| <b>Example</b>   | :ALARm:ANALog:LEVEL ALM1,CH1_1,0.1   |   |
| Query  |  |   |
| <b>Syntax</b>  | Query  | Analog channel alarm<br>:ALARm:ANALog:LEVEL? alm\$,ch\$<br>Waveform calculation channel alarm<br>:ALARm:CALCulate:LEVEL? alm\$,w\$<br>Pulse channel alarm<br>:ALARm:PULSe:LEVEL? alm\$,pls\$  |
|  | Response   | Analog channel alarm<br>alm\$,ch\$,A<NR3> (3 digits after the decimal point)<br>Waveform calculation channel alarm<br>alm\$,w\$,A<NR3> (4 digits after the decimal point)<br>Pulse channel alarm<br>alm\$,pls\$,A<NR3> (9 digits after the decimal point) |
| <b>Example</b>   | :ALARm:ANALog:LEVEL? ALM1,CH1_1<br>(Response) :ALARm:ANALog:LEVEL ALM1,CH1_1,+1.000E-01<br>(When the header is ON) |   |
| Parameter  |  |   |
| <p>alm\$ = ALM1 to ALM4<br/>ch\$ = CH1_1 to CH10_30<br/>w\$ = W1 to W30<br/>pls\$ = PLS1</p> <p>Analog channel alarm<br/>A = Allowable setting range: (Measurement range) × (±1.5),<br/>Maximum resolution: (Measurement range) × (1/1000)</p> <p>Waveform calculation channel alarm<br/>A = -9.9999E+29 to 9.9999E+29</p> <p>Pulse channel alarm<br/>A = 0 to 1000000000 (count), 0 to 15000 (r/s), 0 to 900000 (r/min)</p> <p>If a value greater than the upper limit of the allowable setting range is entered, the maximum value is input.<br/>If a value less than the lower limit of the allowable setting range is entered, the minimum value is input.</p> |  |   |

If the alarm type is **WINDOW**

(1) Set the direction.

| Settings  |   |  |
|---|---|--|
| <b>Syntax</b>   | Command   | Analog channel alarm<br>:ALARm:ANALog:SIDE alm\$,ch\$,A\$<br>Waveform calculation channel alarm<br>:ALARm:CALCulate:SIDE alm\$,w\$,A\$<br>Pulse channel alarm<br>:ALARm:PULSe:SIDE alm\$,pls\$,A\$ |
| <b>Example</b>  | :ALARm:ANALog:SIDE ALM1,CH1_1,IN  |  |
| Query   |   |  |
| <b>Syntax</b>   | Query   | Analog channel alarm<br>:ALARm:ANALog:SIDE? alm\$,ch\$<br>Waveform calculation channel alarm<br>:ALARm:CALCulate:SIDE? alm\$,w\$<br>Pulse channel alarm<br>:ALARm:PULSe:SIDE? alm\$,pls\$          |
|   | Response  | Analog channel alarm<br>alm\$,ch\$,A\$<br>Waveform calculation channel alarm<br>alm\$,w\$,A\$<br>Pulse channel alarm<br>alm\$,pls\$,A\$  |
| <b>Example</b>  | :ALARm:ANALog:SIDE? ALM1,CH1_1<br>(Response) :ALARm:ANALog:SIDE ALM1,CH1_1,IN (When the header is ON)   |  |
| Parameter   |   |  |
| alm\$ = ALM1 to ALM4<br>ch\$ = CH1_1 to CH10_30<br>w\$ = W1 to W30<br>pls\$ = PLS1<br>A\$ = IN, OUT |   |  |
| <b>IN</b> <sup>□</sup>  | Outputs an alarm when the measurement data is equal to or greater than the lower limit value and is equal to or less than the upper limit value.  |  |
| <b>OUT</b>  | Outputs an alarm when the measurement data is less than the lower limit value or greater than the upper limit value. However, for the pulse channel, an alarm will also be output when the measured value is 0, if either the upper or lower limit value is set to 0. |  |

**(2) Set the upper and lower limit values.**

The range between the upper and lower limit values is defined as the window.

**Upper limit value**

| Settings   |  |   |
|--|--|---|
| <b>Syntax</b>  | Command  | Analog channel alarm<br>:ALARm:ANALog:UPPER alm\$,ch\$,A<br>Waveform calculation channel alarm<br>:ALARm:CALCulate:UPPER alm\$,w\$,A<br>Pulse channel alarm<br>:ALARm:PULSe:UPPER alm\$,pls\$,A   |
| <b>Example</b>   | :ALARm:ANALog:UPPER ALM1,CH1_1,0.5   |   |
| Query  |  |   |
| <b>Syntax</b>  | Query  | Analog channel alarm<br>:ALARm:ANALog:UPPER? alm\$,ch\$<br>Waveform calculation channel alarm<br>:ALARm:CALCulate:UPPER? alm\$,w\$<br>Pulse channel alarm<br>:ALARm:PULSe:UPPER? alm\$,pls\$  |
|  | Response   | Analog channel alarm<br>alm\$,ch\$,A<NR3> (3 digits after the decimal point)<br>Waveform calculation channel alarm<br>alm\$,w\$,A<NR3> (4 digits after the decimal point)<br>Pulse channel alarm<br>alm\$,pls\$,A<NR3> (9 digits after the decimal point) |
| <b>Example</b>   | :ALARm:ANALog:UPPER? ALM1,CH1_1<br>(Response) :ALARm:ANALog:UPPER ALM1,CH1_1,+5.000E-01<br>(When the header is ON) |   |
| Parameter  |  |   |
| alm\$ = ALM1 to ALM4<br>ch\$ = CH1_1 to CH10_30<br>w\$ = W1 to W30<br>pls\$ = PLS1<br><br>Analog channel alarm<br>A = Allowable setting range: (Measurement range) × (±1.5),<br>Maximum resolution: (Measurement range) × (1/1000)<br>Waveform calculation channel alarm<br>A = -9.9999E+29 to 9.9999E+29<br>Pulse channel alarm<br>A = 0 to 1000000000 (count), 0 to 15000 (r/s), 0 to 900000 (r/min) |  |   |
| If a value greater than the upper limit of the allowable setting range is entered, the maximum value is input.<br>If a value less than the lower limit of the allowable setting range is entered, the minimum value is input.  |  |   |

**Lower limit value**

| Settings  |  |  |
|---|--|--|
| <b>Syntax</b>   | Command  | Analog channel alarm<br><code>:ALARm:ANALog:LOWEr alm\$,ch\$,A</code><br>Waveform calculation channel alarm<br><code>:ALARm:CALCulate:LOWEr alm\$,w\$,A</code><br>Pulse channel alarm<br><code>:ALARm:PULSe:LOWEr alm\$,pls\$,A</code>   |
| <b>Example</b>  | <code>:ALARm:ANALog:LOWEr ALM1,CH1_1,0.5</code>  |  |
| Query   |  |  |
| <b>Syntax</b>   | Query  | Analog channel alarm<br><code>:ALARm:ANALog:LOWEr? alm\$,ch\$</code><br>Waveform calculation channel alarm<br><code>:ALARm:CALCulate:LOWEr? alm\$,w\$</code><br>Pulse channel alarm<br><code>:ALARm:PULSe:LOWEr? alm\$,pls\$</code>  |
|   | Response   | Analog channel alarm<br><code>alm\$,ch\$,A&lt;NR3&gt;</code> (3 digits after the decimal point)<br>Waveform calculation channel alarm<br><code>alm\$,w\$,A&lt;NR3&gt;</code> (4 digits after the decimal point)<br>Pulse channel alarm<br><code>alm\$,pls\$,A&lt;NR3&gt;</code> (9 digits after the decimal point) |
| <b>Example</b>  | <code>:ALARm:ANALog:LOWEr? ALM1,CH1_1</code><br>(Response) <code>:ALARm:ANALog:LOWEr ALM1,CH1_1,+5.000E-01</code><br>(When the header is ON) |  |
| Parameter   |  |  |
| <p> <code>alm\$</code> = ALM1 to ALM4<br/> <code>ch\$</code> = CH1_1 to CH10_30<br/> <code>w\$</code> = W1 to W30<br/> <code>pls\$</code> = PLS1                 </p> <p>                     Analog channel alarm<br/> <code>A</code> = Allowable setting range: (Measurement range) × (±1.5),<br/>                     Maximum resolution: (Measurement range) × (1/1000)                 </p> <p>                     Waveform calculation channel alarm<br/> <code>A</code> = -9.9999E+29 to 9.9999E+29                 </p> <p>                     Pulse channel alarm<br/> <code>A</code> = 0 to 1000000000 (count), 0 to 15000 (r/s), 0 to 900000 (r/min)                 </p> <p>                     If a value greater than the upper limit of the allowable setting range is entered, the maximum value is input.<br/>                     If a value less than the lower limit of the allowable setting range is entered, the minimum value is input.                 </p> |  |  |

## If the alarm type is SLOPe

## (1) Set the level.

| Settings   |  |   |
|--|--|---|
| Syntax   | Command  | Analog channel alarm<br>:ALARM:ANALog:LEVEL alm\$,ch\$,A<br>Waveform calculation channel alarm<br>:ALARM:CALCulate:LEVEL alm\$,w\$,A<br>Pulse channel alarm<br>:ALARM:PULSe:LEVEL alm\$,pls\$,A   |
| Example  | :ALARM:ANALog:LEVEL ALM1,CH1_1,0.1   |   |
| Query  |  |   |
| Syntax   | Query  | Analog channel alarm<br>:ALARM:ANALog:LEVEL? alm\$,ch\$<br>Waveform calculation channel alarm<br>:ALARM:CALCulate:LEVEL? alm\$,w\$<br>Pulse channel alarm<br>:ALARM:PULSe:LEVEL? alm\$,pls\$  |
|  | Response   | Analog channel alarm<br>alm\$,ch\$,A<NR3> (3 digits after the decimal point)<br>Waveform calculation channel alarm<br>alm\$,w\$,A<NR3> (4 digits after the decimal point)<br>Pulse channel alarm<br>alm\$,pls\$,A<NR3> (9 digits after the decimal point) |
| Example  | :ALARM:ANALog:LEVEL? ALM1,CH1_1<br>(Response) :ALARM:ANALOG:LEVEL ALM1,CH1_1,+1.000E-01<br>(When the header is ON) |   |
| Parameter  |  |   |
| alm\$ = ALM1 to ALM4<br>ch\$ = CH1_1 to CH10_30<br>w\$ = W1 to W30<br>pls\$ = PLS1<br><br>Analog channel alarm<br>A = Allowable setting range: (Measurement range) × (±1.5),<br>Maximum resolution: (Measurement range) × (1/1000)<br>Waveform calculation channel alarm<br>A = -9.9999E+29 to 9.9999E+29<br>Pulse channel alarm<br>A = 0 to 1000000000 (count), 0 to 15000 (r/s), 0 to 900000 (r/min) |  |   |

## (2) Set the time.

| Settings  |  |  |
|---|--|--|
| <b>Syntax</b>   | Command  | Analog channel alarm<br>:ALARm:ANALog:STIME alm\$,ch\$,hour,min,sec<br>Waveform calculation channel alarm<br>:ALARm:CALCulate:STIME alm\$,w\$,hour,min,sec<br>Pulse channel alarm<br>:ALARm:PULSe:STIME alm\$,pls\$,hour,min,sec |
| <b>Example</b>  | :ALARm:ANALog:STIME ALM1,CH1_1,0,1,20  |  |
| Query   |  |  |
| <b>Syntax</b>   | Query  | Analog channel alarm<br>:ALARm:ANALog:STIME? alm\$,ch\$<br>Waveform calculation channel alarm<br>:ALARm:CALCulate:STIME? alm\$,w\$<br>Pulse channel alarm<br>:ALARm:PULSe:STIME? alm\$,pls\$                                     |
|   | Response   | Analog channel alarm<br>alm\$,ch\$,hour<NR1>,min<NR1>,sec<NR1><br>Waveform calculation channel alarm<br>alm\$,w\$,hour<NR1>,min<NR1>,sec<NR1><br>Pulse channel alarm<br>alm\$,pls\$,hour<NR1>,min<NR1>,sec<NR1>                  |
| <b>Example</b>  | :ALARm:ANALog:STIME? ALM1,CH1_1<br>(Response) :ALARm:ANALOG:STIME ALM1,CH1_1,0,1,20<br>(When the header is ON) |  |
| Parameter   |  |  |
| <p>alm\$ = ALM1 to ALM4<br/> ch\$ = CH1_1 to CH10_30<br/> w\$ = W1 to W30<br/> pls\$ = PLS1</p> <p>hour = 0 to 6 (hour)*1<br/> min = 0 to 59 (min)*1<br/> sec = 0 to 59 (sec)*1</p> <p>*1. Input in the format of A&lt;NR1&gt;.<br/> See "Data part" (p. 23).</p> <p>0,0,0 cannot be entered.</p> |  |  |

## If the alarm type is SLOPE2

## (1) Set the slope.

| Settings  |   |   |
|---|---|---|
| <b>Syntax</b>   | Command   | Analog channel alarm<br>:ALARm:ANALog:SLOPe alm\$,ch\$,A\$<br>Waveform calculation channel<br>:ALARm:CALCulate:SLOPe alm\$,w\$,A\$<br>Pulse channel<br>:ALARm:PULSe:SLOPe alm\$,pls\$,A\$ |
| <b>Example</b>  | :ALARm:ANALog:SLOPe ALM1,CH1_1,HIGH   |   |
| Query   |   |   |
| <b>Syntax</b>   | Query   | Analog channel alarm<br>:ALARm:ANALog:SLOPe? alm\$,ch\$<br>Waveform calculation channel<br>:ALARm:CALCulate:SLOPe? alm\$,w\$<br>Pulse channel<br>:ALARm:PULSe:SLOPe? alm\$,pls\$          |
|   | Response  | Analog channel alarm<br>alm\$,ch\$,A\$<br>Waveform calculation channel alarm<br>alm\$,w\$,A\$<br>Pulse channel alarm<br>alm\$,pls\$,A\$   |
| <b>Example</b>  | :ALARm:ANALog:SLOPe? ALM1,CH1_1<br>(Response) :ALARm:ANALog:SLOPe ALM1,CH1_1,HIGH (When the header is ON) |   |
| Parameter   |   |   |
| alm\$ = ALM1 to ALM4<br>ch\$ = CH1_1 to CH10_30<br>w\$ = W1 to W30<br>pls\$ = PLS1<br>A\$ = HIGH, LOW |   |   |
| <b>HIGH</b> <sup>□</sup>  | Outputs an alarm when the measurement data is equal to or greater than the specified level.               |   |
| <b>LOW</b>  | Outputs an alarm when the measurement data is less than the specified level.                              |   |

(2) Set the level.

| Settings  |  |  |
|---|--|--|
| Syntax  | Command  | Analog channel alarm<br><code>:ALARm:ANALog:LEVEL alm\$,ch\$,A</code><br>Waveform calculation channel alarm<br><code>:ALARm:CALCulate:LEVEL alm\$,w\$,A</code><br>Pulse channel alarm<br><code>:ALARm:PULSe:LEVEL alm\$,pls\$,A</code>   |
| Example   | <code>:ALARm:ANALog:LEVEL ALM1,CH1_1,0.1</code>  |  |
| Query   |  |  |
| Syntax  | Query  | Analog channel alarm<br><code>:ALARm:ANALog:LEVEL? alm\$,ch\$</code><br>Waveform calculation channel alarm<br><code>:ALARm:CALCulate:LEVEL? alm\$,w\$</code><br>Pulse channel alarm<br><code>:ALARm:PULSe:LEVEL? alm\$,pls\$</code>  |
|   | Response   | Analog channel alarm<br><code>alm\$,ch\$,A&lt;NR3&gt;</code> (3 digits after the decimal point)<br>Waveform calculation channel alarm<br><code>alm\$,w\$,A&lt;NR3&gt;</code> (4 digits after the decimal point)<br>Pulse channel alarm<br><code>alm\$,pls\$,A&lt;NR3&gt;</code> (9 digits after the decimal point) |
| Example   | <code>:ALARm:ANALog:LEVEL? ALM1,CH1_1</code><br>(Response) <code>:ALARm:ANALog:LEVEL ALM1,CH1_1,+1.000E-01</code><br>(When the header is ON) |  |
| Parameter   |  |  |
| <p> <code>alm\$</code> = ALM1 to ALM4<br/> <code>ch\$</code> = CH1_1 to CH10_30<br/> <code>w\$</code> = W1 to W30<br/> <code>pls\$</code> = PLS1                 </p> <p>                     Analog channel alarm<br/> <code>A</code> = Allowable setting range: (Measurement range) × (±1.5),<br/>                     Maximum resolution: (Measurement range) × (1/1000)                 </p> <p>                     Waveform calculation channel alarm<br/> <code>A</code> = -9.9999E+29 to 9.9999E+29                 </p> <p>                     Pulse channel alarm<br/> <code>A</code> = 0 to 1000000000 (count), 0 to 15000 (r/s), 0 to 900000 (r/min)                 </p> <p>                     If a value greater than the upper limit of the allowable setting range is entered, the maximum value is input.<br/>                     If a value less than the lower limit of the allowable setting range is entered, the minimum value is input.                 </p> |  |  |



## (3) Set the time.

| Settings  |   |   |
|---|---|---|
| <b>Syntax</b>   | Command   | Analog channel alarm<br>:ALARM:ANALog:SLP2:TIME alm\$,ch\$,hour,min,sec,ms<br>Waveform calculation channel alarm<br>:ALARM:CALCulate:SLP2:TIME alm\$,w\$,hour,min,sec,ms<br>Pulse channel alarm<br>:ALARM:PULSe:SLP2:TIME alm\$,pls\$,hour,min,sec,ms |
| <b>Example</b>  | :ALARM:ANALog:SLP2:TIME ALM1,CH1_1,0,1,20,30  |   |
| Query   |   |   |
| <b>Syntax</b>   | Query   | Analog channel alarm<br>:ALARM:ANALog:SLP2:TIME? alm\$,ch\$<br>Waveform calculation channel alarm<br>:ALARM:CALCulate:SLP2:TIME? alm\$,w\$<br>Pulse channel alarm<br>:ALARM:PULSe:SLP2:TIME? alm\$,pls\$  |
|   | Response  | Analog channel alarm<br>alm\$,ch\$,hour<NR1>,min<NR1>,sec<NR1>,ms<NR1><br>Waveform calculation channel alarm<br>alm\$,w\$,hour<NR1>,min<NR1>,sec<NR1>,ms<NR1><br>Pulse channel alarm<br>alm\$,pls\$,hour<NR1>,min<NR1>,sec<NR1>,ms<NR1>               |
| <b>Example</b>  | :ALARM:ANALog:SLP2:TIME? ALM1,CH1_1<br>(Response) :ALARM:ANALog:SLP2:TIME ALM1,CH1_1,0,1,20,30<br>(When the header is ON) |   |
| Parameter   |   |   |
| <p>alm\$ = ALM1 to ALM4<br/> ch\$ = CH1_1 to CH10_30<br/> w\$ = W1 to W30<br/> pls\$ = PLS1</p> <p>hour = 0 to 24 (hour)*1<br/> min = 0 to 59 (min)*1<br/> sec = 0 to 59 (sec)*1<br/> ms = 0 to 999 (msec)*1</p> <p>*1. Input in the format of A&lt;NR1&gt;.<br/> See "Data part" (p. 23).</p> <p>0,0,0,0 cannot be entered.<br/> A time equal to or greater than "10000 × Recording interval" cannot be set.<br/> A value can be set up to 24 hours.</p> |   |   |

## 2 When the input type for the logic channel (PLS1) is logic.

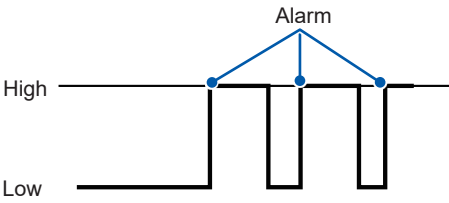
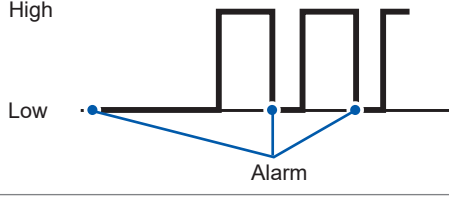
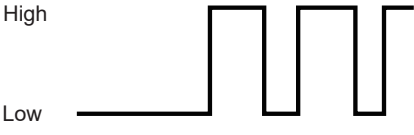
|         |       |                      |          |  |   |
|---------|-------|----------------------|----------|--|---|
| Pattern | Level | 1, 0, X <sup>☐</sup> | <b>1</b> |  | Outputs an alarm when the logic signal is 1 (High). |
|         |       |                      | <b>0</b> |  | Outputs an alarm when the logic signal is 0 (Low).  |
|         |       |                      | <b>X</b> |  | Not used for alarm judgment. Ignores the signal.    |

| Settings   |  |  |
|--|--|--|
| Syntax   | Command  | <code>:ALARm:LOGic:PATtern alm\$, "A\$"</code>   |
| Example  |  | <code>:ALARm:LOGic:PATtern ALM1, "1"</code>  |
| Query  |  |  |
| Syntax   | Query  | <code>:ALARm:LOGic:PATtern? alm\$</code>   |
|  | Response                                       | <code>"A\$"</code>   |
| Example  |  | <code>:TRIGger:LOGic:STARt:PATtern?</code><br>(Response) <code>:ALARm:LOGic:PATtern ALM1, "1"</code> (When the header is ON) |
| Parameter  |  |  |
| <code>alm\$</code> = ALM1 to ALM4<br><code>A\$</code> = 1, 0, X<br>Alarm pattern |  |  |
| <b>1</b>   | An alarm is issued with the High level signal. |  |
| <b>0</b>   | An alarm is issued with the Low level signal.  |  |
| <b>X<sup>☐</sup></b>   | No alarm is applied. Ignores the signal.       |  |

## 7.2 Checking Alarm

### 1 Check the alarm history.

#### (1) Check the number of alarms.

| Query                          |   |                 |
|--------------------------------|---|-----------------|
| Syntax                         | Query   | :ALARm:ARCDNum? |
|                                | Response  | A<NR1>          |
| Example                        | :ALARm:ARCDNum?<br>(Response) :ALARM:ARCDNUM 10 (When the header is ON) |                 |
| Parameter                      |   |                 |
| A = 0 to 999999 (0 = no alarm) |   |                 |

#### (2) Check the details of the alarm history.

- Check the details of the target alarm history from the number obtained with the number of alarms.
- The formats of the issuance and cancellation times follow the settings for the horizontal (time) axis display. (p.228)
- If the alarm is not canceled, the cancellation time is hyphen (-).
- When a thermocouple wire break occurs, the channel number is hyphen (-).
- The details can be checked for up to the latest 100 alarms in the alarm history.

| Query   |  |                                      |
|---|--|--------------------------------------|
| Syntax  | Query  | :ALARm:ARCD? NO                      |
|   | Response   | NO<NR1>,ALM\$,CH\$,ERR\$,STR\$,END\$ |
| Example                                       | :ALARm:ARCD? 1<br>(Response) :ALARM:ARCD 1,ALM1,CH1_1,-, 20ms, 60ms<br>(When the header is ON) |                                      |
| Parameter                                     |  |                                      |
| NO = Alarm history number (1 to 999999)       |  |                                      |
| ALM\$ = ALM1 to ALM4                          |  |                                      |
| CH\$ = CH1_1 to CH10_30, PLS1, W1 to W30      |  |                                      |
| ERR\$ = -, BURN_OUT (thermocouple wire break) |  |                                      |
| STR\$ = Time of occurrence                    |  |                                      |
| END\$ = Time of cancellation                  |  |                                      |

### 2 Cancel the alarm.

When the alarm output hold is set to ON, the alarm can be canceled with the following command. The alarm cannot be canceled if the alarm condition is satisfied.

| Settings |                   |                 |
|----------|-------------------|-----------------|
| Syntax   | Command           | :ALARm:HOLD A\$ |
| Example  | :ALARm:HOLD CLEAR |                 |

For the settings of the alarm function, alarm output hold, and alarm buzzer, see "7.1 Setting Alarms" (p. 185).



When Logger Utility is used, an event mark is displayed at the top of the screen.

## 8.1 Placing Event Marks During Measurement

It is useful for analysis if event marks are placed at the timing of operations during the measurement.

This feature allows you to see how the waveform changes when the object being measured performs a certain operation.

Up to 1000 event marks can be placed per measurement.

The event numbers are reset when the next measurement is started.

### 1 Check the event mark setting and the number of event marks already set.

| Settings                   |   |                             |
|----------------------------|---|-----------------------------|
| Syntax                     | Command   | <code>:DISPlay:MARK</code>  |
| Example                    | <code>:DISPlay:MARK</code>  |                             |
| Query                      |   |                             |
| Syntax                     | Query   | <code>:DISPlay:MARK?</code> |
|                            | Response  | <code>A&lt;NR1&gt;</code>   |
| Example                    | <code>:DISPlay:MARK?</code><br>(Response) <code>:DISPlay:MARK 10</code> (When the header is ON) |                             |
| Parameter                  |   |                             |
| <code>A</code> = 0 to 1000 |   |                             |

### 2 Check the data number of the event mark position.

| Query                                       |   |   |
|---|---|---|
| Syntax                                      | Query   | <code>:DISPlay:MARKJump? A</code>       |
|   | Response  | <code>A&lt;NR1&gt;, B&lt;NR1&gt;</code> |
| Example                                     | <code>:DISPlay:MARKJump? 10</code><br>(Response) <code>:DISPlay:MARKJUMP 10, 500</code> (When the header is ON) |   |
| Parameter                                   |   |   |
| <code>A</code> = 1 to number of event marks |   |   |
| <code>B</code> = Data number                |   |   |

## 8.2 Placing Event Marks With External Signals

Event marks can be added using external signals.  
 The settings need to be configured before starting the measurement.

### 1 Set the event input for external inputs 1 to 3.

| Settings  |  |   |
|---|--|---|
| <b>Syntax</b>   | Command  | :SYSTem:EXT:IO1:KIND A\$ (External input 1)<br>:SYSTem:EXT:IO2:KIND A\$ (External input 2)<br>:SYSTem:EXT:IO3:KIND A\$ (External input 3) |
| <b>Example</b>  | :SYSTem:EXT:IO1:KIND EVENTIN   |   |
| Query   |  |   |
| <b>Syntax</b>   | Query  | :SYSTem:EXT:IO1:KIND? (External input 1)<br>:SYSTem:EXT:IO2:KIND? (External input 2)<br>:SYSTem:EXT:IO3:KIND? (External input 3)          |
|   | Response   | A\$   |
| <b>Example</b>  | :SYSTem:EXT:IO1:KIND?<br>(Response) :SYSTEM:EXT:IO1:KIND EVENTIN (When the header is ON) |   |
| Parameter   |  |   |
| For external inputs 1 and 2<br>A\$ = OFF, STARTIN, STOPIN, S_SIN, EVENTIN |  |   |
| OFF <sup>☐</sup>  | Disables the terminal.   |   |
| STARTIN   | Start<br>Starts measurement.   |   |
| STOPIN  | Stop<br>Stops measurement.   |   |
| S_SIN   | Start/stop<br>Starts or stops measurement based on changes in the signal level.          |   |
| EVENTIN   | Event input<br>Places an event mark.   |   |
| For external input 3<br>A\$ = OFF, TRIGIN, EVENTIN                        |  |   |
| OFF <sup>☐</sup>  | Disables the external input.   |   |
| TRIGIN  | Trigger input<br>The trigger is activated.   |   |
| EVENTIN   | Event input<br>Places an event mark.   |   |

## 8.3 Placing an Event Mark When an Alarm is Issued

An event mark can be placed when an alarm is issued.  
The settings need to be configured before starting the measurement.

### 1 Set whether or not to place an event mark when an alarm is issued.

If the parameter is set to ON, an event mark and number are placed when an alarm is issued.  
See “7 Alarm (Alarm Output)” (p. 185).

| Settings                                |   |                  |
|---|---|------------------|
| Syntax                                  | Command   | :SYSTem:MARK A\$ |
| Example                                 | :SYSTem:MARK ON   |                  |
| Query                                   |   |                  |
| Syntax                                  | Query   | :SYSTem:MARK?    |
|   | Response  | A\$              |
| Example                                 | :SYSTem:MARK?<br>(Response) :SYSTEM:MARK ON (When the header is ON) |                  |
| Parameter                               |   |                  |
| A\$ = OFF, ON                           |   |                  |
| OFF <input checked="" type="checkbox"/> | No event mark is placed when an alarm is issued.                    |                  |
| ON                                      | An event mark is placed when an alarm is issued.                    |                  |

## 8.4 Checking Events in CSV Data

When the waveform data are saved in text format (CSV) using the instrument, event numbers are inserted alongside the measurement data.

This allows you to verify which data is associated with which event.

Event number

|               |                        |           |           |           |           |           |           |           |           |           |       |
|---------------|------------------------|-----------|-----------|-----------|-----------|-----------|-----------|-----------|-----------|-----------|-------|
| File name     | AUTO0003V1.00          |           |           |           |           |           |           |           |           |           |       |
| Title comment |                        |           |           |           |           |           |           |           |           |           |       |
| Trigger Time  | '23-07-17 07:58:52.494 |           |           |           |           |           |           |           |           |           |       |
| CH            | CH1-1                  | CH1-2     | CH1-3     | CH1-4     | CH1-5     | CH1-6     | CH1-7     | CH1-8     | CH1-9     | CH1-10    | Event |
| Mode          | Voltage                | Voltage   | Voltage   | Voltage   | Voltage   | Voltage   | Voltage   | Voltage   | Voltage   | Voltage   |       |
| Range         | 100mV                  | 100mV     | 100mV     | 100mV     | 100mV     | 100mV     | 100mV     | 100mV     | 100mV     | 100mV     |       |
| ModuleID      |                        |           |           |           |           |           |           |           |           |           |       |
| Comment       |                        |           |           |           |           |           |           |           |           |           |       |
| Scaling       | OFF                    | OFF       | OFF       | OFF       | OFF       | OFF       | OFF       | OFF       | OFF       | OFF       |       |
| Ratio         | 1.00E+00               | 1.00E+00  | 1.00E+00  | 1.00E+00  | 1.00E+00  | 1.00E+00  | 1.00E+00  | 1.00E+00  | 1.00E+00  | 1.00E+00  |       |
| Offset        | 0.00E+00               | 0.00E+00  | 0.00E+00  | 0.00E+00  | 0.00E+00  | 0.00E+00  | 0.00E+00  | 0.00E+00  | 0.00E+00  | 0.00E+00  |       |
| Time          | CH1-1[V]               | CH1-2[V]  | CH1-3[V]  | CH1-4[V]  | CH1-5[V]  | CH1-6[V]  | CH1-7[V]  | CH1-8[V]  | CH1-9[V]  | CH1-10[V] | Event |
| 0.00E+00      | -1.00E-02              | -1.00E-02 | -1.00E-02 | -1.00E-02 | -1.00E-02 | -1.00E-02 | -9.99E-03 | -9.99E-03 | -9.99E-03 | -9.99E-03 | 0     |
| 1.00E+00      | -1.00E-02              | -1.00E-02 | -1.00E-02 | -1.00E-02 | -1.00E-02 | -1.00E-02 | -9.99E-03 | -9.99E-03 | -9.99E-03 | -9.99E-03 | 0     |
| 2.00E+00      | -1.00E-02              | -1.00E-02 | -1.00E-02 | -1.00E-02 | -9.99E-03 | -9.99E-03 | -9.99E-03 | -9.99E-03 | -9.99E-03 | -9.99E-03 | 0     |
| 3.00E+00      | -1.00E-02              | -1.00E-02 | -1.00E-02 | -9.99E-03 | -9.99E-03 | -9.99E-03 | -9.99E-03 | -9.99E-03 | -9.99E-03 | -9.99E-03 | 1     |
| 4.00E+00      | -1.00E-02              | -1.00E-02 | -9.99E-03 | -9.99E-03 | -9.99E-03 | -9.99E-03 | -9.99E-03 | -9.99E-03 | -9.99E-03 | -9.99E-03 | 0     |
| 5.00E+00      | -1.00E-02              | -9.99E-03 | -9.99E-03 | -9.99E-03 | -9.99E-03 | -9.99E-03 | -9.99E-03 | -9.99E-03 | -9.99E-03 | -9.99E-03 | 2     |
| 6.00E+00      | -9.99E-03              | -9.99E-03 | -9.99E-03 | -9.99E-03 | -9.99E-03 | -9.99E-03 | -9.99E-03 | -9.99E-03 | -9.99E-03 | -9.99E-03 | 0     |
| 7.00E+00      | -9.99E-03              | -9.99E-03 | -9.99E-03 | -9.99E-03 | -9.99E-03 | -9.99E-03 | -9.99E-03 | -9.99E-03 | -9.99E-03 | -9.98E-03 | 3     |
| 8.00E+00      | -9.99E-03              | -9.99E-03 | -9.99E-03 | -9.99E-03 | -9.99E-03 | -9.99E-03 | -9.99E-03 | -9.99E-03 | -9.98E-03 | -9.98E-03 | 0     |
| 9.00E+00      | -9.99E-03              | -9.99E-03 | -9.99E-03 | -9.99E-03 | -9.99E-03 | -9.99E-03 | -9.99E-03 | -9.98E-03 | -9.98E-03 | -9.98E-03 | 0     |
| 1.00E+01      | -9.99E-03              | -9.99E-03 | -9.99E-03 | -9.99E-03 | -9.99E-03 | -9.99E-03 | -9.98E-03 | -9.98E-03 | -9.98E-03 | -9.98E-03 | 4     |
| 1.10E+01      | -9.99E-03              | -9.99E-03 | -9.99E-03 | -9.99E-03 | -9.99E-03 | -9.98E-03 | -9.98E-03 | -9.98E-03 | -9.98E-03 | -9.98E-03 | 0     |
| 1.20E+01      | -9.99E-03              | -9.99E-03 | -9.99E-03 | -9.99E-03 | -9.98E-03 | -9.98E-03 | -9.98E-03 | -9.98E-03 | -9.98E-03 | -9.98E-03 | 0     |
| 1.30E+01      | -9.99E-03              | -9.99E-03 | -9.99E-03 | -9.98E-03 | -9.98E-03 | -9.98E-03 | -9.98E-03 | -9.98E-03 | -9.98E-03 | -9.98E-03 | 5     |
| 1.40E+01      | -9.99E-03              | -9.99E-03 | -9.98E-03 | -9.98E-03 | -9.98E-03 | -9.98E-03 | -9.98E-03 | -9.98E-03 | -9.98E-03 | -9.98E-03 | 0     |
| 1.50E+01      | -9.99E-03              | -9.98E-03 | -9.98E-03 | -9.98E-03 | -9.98E-03 | -9.98E-03 | -9.98E-03 | -9.98E-03 | -9.98E-03 | -9.98E-03 | 0     |
| 1.60E+01      | -9.98E-03              | -9.98E-03 | -9.98E-03 | -9.98E-03 | -9.98E-03 | -9.98E-03 | -9.98E-03 | -9.98E-03 | -9.98E-03 | -9.98E-03 | 6     |
| 1.70E+01      | -9.98E-03              | -9.98E-03 | -9.98E-03 | -9.98E-03 | -9.98E-03 | -9.98E-03 | -9.98E-03 | -9.98E-03 | -9.98E-03 | -9.97E-03 | 0     |
| 1.80E+01      | -9.98E-03              | -9.98E-03 | -9.98E-03 | -9.98E-03 | -9.98E-03 | -9.98E-03 | -9.98E-03 | -9.98E-03 | -9.97E-03 | -9.97E-03 | 0     |
| 1.90E+01      | -9.98E-03              | -9.98E-03 | -9.98E-03 | -9.98E-03 | -9.98E-03 | -9.98E-03 | -9.98E-03 | -9.97E-03 | -9.97E-03 | -9.97E-03 | 0     |
| 2.00E+01      | -9.98E-03              | -9.98E-03 | -9.98E-03 | -9.98E-03 | -9.98E-03 | -9.98E-03 | -9.97E-03 | -9.97E-03 | -9.97E-03 | -9.97E-03 | 0     |
| 2.10E+01      | -9.98E-03              | -9.98E-03 | -9.98E-03 | -9.98E-03 | -9.98E-03 | -9.97E-03 | -9.97E-03 | -9.97E-03 | -9.97E-03 | -9.97E-03 | 0     |



# Numerical and Waveform Calculation

The instrument can perform numerical calculations and waveform calculations.

The numerical calculations are calculations of maximum value, minimum value, etc. for the measured waveforms.

The waveform calculations are performed using waveforms, including addition and multiplication of waveforms between the channels.

## 9.1 Performing Numerical Calculation

Perform calculations during the measurement.

Set the numerical calculation before starting the measurement. Calculations are performed in real time during the measurement.

Set the numerical calculations before starting the measurement. (p.210)  
Calculations are performed in real time during the measurement.

- You can check the latest calculation values using the commands.
- In addition, the calculation values at regular intervals can be saved in the text format. (p. 164)

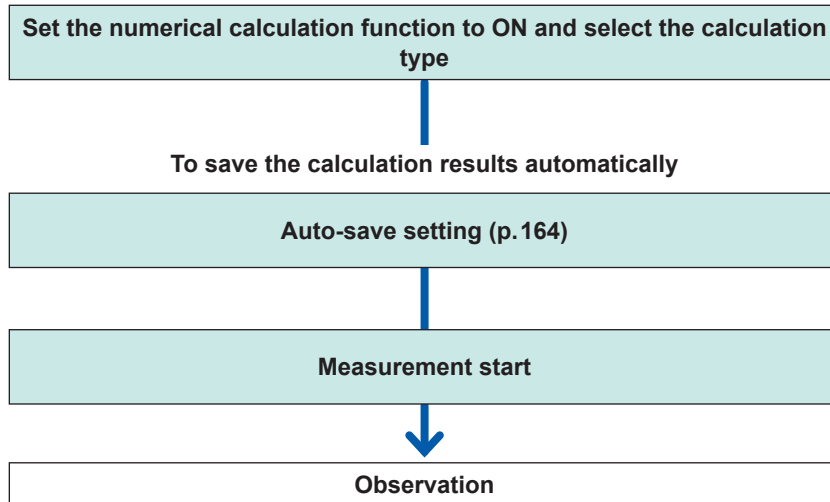

In the following cases, the calculated value and saved data are handled according to “14.12 Data Handling” (p. 336).

- When the waveform significantly exceeds the allowable measurement range of each range (+OVER, -OVER)
- When a thermocouple wire break is detected during temperature measurement (wire break detection)

## Setting the numerical calculations

### 1 Set the numerical calculation function to ON.

| Settings                     |   |                        |
|------------------------------|---|------------------------|
| Syntax                       | Command   | :CALCulate:MEASure A\$ |
| Example                      | :CALCulate:MEASure ON   |                        |
| Query                        |   |                        |
| Syntax                       | Query   | :CALCulate:MEASure?    |
|                              | Response  | A\$                    |
| Example                      | :CALCulate:MEASure?<br>(Response) :CALCULATE:MEASURE ON (When the header is ON) |                        |
| Parameter                    |   |                        |
| A\$ = OFF, ON                |   |                        |
| OFF <input type="checkbox"/> | Disabled  |                        |
| ON                           | Activated   |                        |

### 2 Set the method to save the numerical calculation results in the auto-save operation.

If the parameter is set to DIVide (divided) or ONTIME (divided on time), the calculation results at regular intervals are saved.

If the format for the numerical calculation results in the auto-save operation is set to OFF (division disabled), the time-divided calculation cannot be set.

See "Auto save (Realtime save)" (p. 164).

Set the format for the numerical calculation results to CSV (text format).

When an external sampling is used, only OFF (Disable) can be set.

| Settings                     |   |                          |
|------------------------------|---|--------------------------|
| Syntax                       | Command   | :CALCulate:MEAS:KIND A\$ |
| Example                      | :CALCulate:MEAS:KIND DIVide   |                          |
| Query                        |   |                          |
| Syntax                       | Query   | :CALCulate:MEAS:KIND?    |
|                              | Response  | A\$                      |
| Example                      | :CALCulate:MEAS:KIND?<br>(Response) :CALCULATE:MEAS:KIND DIVIDE (When the header is ON)   |                          |
| Parameter                    |   |                          |
| A\$ = OFF, DIVide, ONTIME    |   |                          |
| OFF <input type="checkbox"/> | Division disabled<br>The numerical calculations are performed for all data since measurement is started until it is stopped, and the calculation results are saved.   |                          |
| DIVide                       | Division enabled<br>The numerical calculations are divided and performed at the specified intervals starting from the measurement start*1, and the calculation results for each interval are saved.<br>*1. If the trigger is used, the numerical calculations are started from the start trigger. |                          |
| ONTIME                       | Divided on time<br>The length of the first section is automatically adjusted so that the calculation values at regular intervals (division time) can be saved based on the reference time (only the first section is shortened from the division time).   |                          |

(When the time-divided calculation is set to DIVide)

**Set the time interval to perform the calculation.**

For example, if the division time is set to 10 minutes, the calculation is performed, and the calculation results are saved every 10 minutes.

|  |   |
|--|---|
| <p>Measurement start      Reference time      Measurement stop</p> | <p>The calculation results are saved at the specified intervals after starting the measurement.<br/>The division time cannot be set to 0 days, 0 hours and 0 minutes. It is automatically updated to 0 days, 0 hours, and 1 minute.</p> |
|--|---|

| Settings                 |                   |   |
|--------------------------|-------------------|---|
| Syntax                   | Command           | <code>:CALCulate:MEAS:LEN day, hour, min</code>   |
| Example                  |                   | <code>:CALCulate:MEAS:LEN 0, 1, 30</code>   |
| Query                    |                   |   |
| Syntax                   | Query             | <code>:CALCulate:MEAS:LEN?</code>   |
|                          | Response          | <code>day&lt;NR1&gt;, hour&lt;NR1&gt;, min&lt;NR1&gt;</code>  |
| Example                  |                   | <code>:CALCulate:MEAS:LEN?</code><br>(Response) <code>:CALCulate:MEAS:LEN 0, 1, 30</code> (When the header is ON) |
| Parameter                |                   |   |
| <code>day</code>         | 0 to 30 (days)    |   |
| <code>hour</code>        | 0 to 23 (hours)   |   |
| <code>min</code>         | 0 to 59 (minutes) |   |
| See "Data part" (p. 23). |                   |   |

(When the time-divided calculation is set to ONTIME)

**Set the time that serves as a reference for dividing a file.**

| Settings                 |                   |  |
|--------------------------|-------------------|--|
| Syntax                   | Command           | <code>:CALCulate:MEAS:REG hour, min</code>   |
| Example                  |                   | <code>:CALCulate:MEAS:REG 1, 30</code>   |
| Query                    |                   |  |
| Syntax                   | Query             | <code>:CALCulate:MEAS:REG?</code>  |
|                          | Response          | <code>hour&lt;NR1&gt;, min&lt;NR1&gt;</code>   |
| Example                  |                   | <code>:CALCulate:MEAS:REG?</code><br>(Response) <code>:CALCulate:MEAS:REG 1, 30</code> (When the header is ON) |
| Parameter                |                   |  |
| <code>hour</code>        | 0 to 23 (hours)   |  |
| <code>min</code>         | 0 to 59 (minutes) |  |
| See "Data part" (p. 23). |                   |  |

**Set the period to divide a file.**

| Settings   |          |  |
|--|----------|--|
| Syntax   | Command  | :CALCulate:MEAS:TIME A                                     |
| Example  |          | :CALCulate:MEAS:TIME 1                                     |
| Query  |          |  |
| Syntax   | Query    | :CALCulate:MEAS:TIME?                                      |
|  | Response | A<NR1>   |
| Example  |          | :CALCulate:MEAS:TIME?<br>(Response) :CALCULATE:MEAS:TIME 1 |
| Parameter  |          |  |
| A = 1, 2, 5, 10, 15, 20, 30, 60, 120, 180, 240, 360, 480, 720, 1440 (unit min) |          |  |

|   |  |
|---|--|
| <p>The diagram shows a sine wave with three full cycles. Vertical blue lines mark the 'Measurement start', 'Reference time', and 'Measurement stop'. A 'First section' is indicated by a double-headed arrow from the start to the first peak. A 'Split time' is indicated by a double-headed arrow between two peaks. A dotted vertical line is at the 'Reference time'.</p> | <p>The calculation results are saved at the specified intervals based on the reference time. The first section after starting the measurement is automatically adjusted to ensure that the calculated results are saved at intervals based on the division time, starting from the reference time.</p> |
|---|--|

### 3 Set the numerical calculation type.

Up to 10 numerical calculations can be set simultaneously.

| Settings  |   |                              |
|---|---|------------------------------|
| Syntax  | Command   | :CALCulate:MEAS:SET no\$,A\$ |
| Example   | :CALCulate:MEAS:SET NO1,AVE   |                              |
| Query   |   |                              |
| Syntax  | Query   | :CALCulate:MEAS:SET? no\$    |
|   | Response  | no\$,A\$                     |
| Example   | :CALCulate:MEAS:SET? NO1<br>(Response) :CALCulate:MEAS:SET NO1,AVE                                      |                              |
| Parameter   |   |                              |
| no\$ = NO1 to NO10  |   |                              |
| A\$ = OFF, AVE, PP, MAX, MIN, MAXT, MINT, ACC, INT, OPE, ONT, OFFT, ONC, OFFC   |   |                              |
| OFF <sup>□</sup>  | No calculation  |                              |
| AVE   | Average   |                              |
| PP  | P-P value (difference between the maximum and the minimum)  |                              |
| MAX   | Maximum   |                              |
| MIN   | Minimum   |                              |
| MAXT  | Time to reach the maximum since the start of recording*1  |                              |
| MINT  | Time to reach the minimum since the start of recording*1  |                              |
| ACC   | Integrated value  |                              |
| INT   | Integral value  |                              |
| OPE   | Operation rate (ratio when the measured value is equal to or greater than the threshold value)          |                              |
| ONT   | ON time (total time when the measured value is equal to or greater than the threshold value)            |                              |
| OFFT  | OFF time (total time when the measured value is less than the threshold value)                          |                              |
| ONC   | ON count (number of times when the measured value becomes equal to or greater than the threshold value) |                              |
| OFFC  | OFF count (number of times when the measured value becomes less than the threshold value)               |                              |
| *1. When the trigger is used, the time from the trigger point is calculated.<br>Only one threshold value can be set to each channel. If the same channel is specified for the ON and OFF times, the same threshold value is used. |   |                              |

**4** Set the target channels to perform the numerical calculations.

| Settings  |  |                                  |
|---|--|----------------------------------|
| Syntax  | Command  | :CALCulate:MEAS:TARGET no\$,ch\$ |
| Example   | :CALCulate:MEAS:TARGET NO1,CH1_1   |                                  |
| Query   |  |                                  |
| Syntax  | Query  | :CALCulate:MEAS:TARGET? no\$     |
|   | Response   | no\$,ch\$                        |
| Example   | :CALCulate:MEAS:TARGET? NO1<br>(Response) :CALCULATE:MEAS:TARGET NO1,CH1_1 (When the header is ON)           |                                  |
| Parameter   |  |                                  |
| no\$ = NO1 to NO10<br>ch\$ = ALL, CH1_1 to CH10_30, PLS1, W1 to W30 |  |                                  |
| ALL <sup>□</sup>  | Uses waveforms of all channels to perform the numerical calculations.  |                                  |
| CH1_1 to CH10_30  | Uses only waveforms of the specified channels to perform the numerical calculations. (n = 1, 2, ...)         |                                  |
| PLS1  | Performs the numerical calculations on pulse waveforms.  |                                  |
| W1 to W30   | Performs the numerical calculations on the waveforms on which the waveform calculations have been performed. |                                  |

**5** (When the operation type is set to OPE [Usage ratio], ONT [ON time], OFFT [OFF time], ONC [ON count], or OFFC [OFF count])

Set the threshold value as a reference.

| Settings  |   |   |
|---|---|---|
| Syntax  | Command   | :CALCulate:MEAS:LEVEL ch\$,A                  |
| Example   | :CALCulate:MEAS:LEVEL CH1_1,0.123   |   |
| Query   |   |   |
| Syntax  | Query   | :CALCulate:MEAS:LEVEL? ch\$                   |
|   | Response  | ch\$,A<NR3> (4 digit after the decimal point) |
| Example   | :CALCulate:MEAS:LEVEL? CH1_1<br>(Response) :CALCULATE:MEAS:LEVEL CH1_1,+1.2340E-01<br>(When the header is ON) |   |
| Parameter   |   |   |
| ch\$ = CH1_1 to CH10_30, PLS1, W1 to W30<br>A = -9.9999E+29 to 9.9999E+29 |   |   |

## 6 (When the operation type is set to ACC (integrated value) or INT (integral value))

Select the calculation method.

For details about the calculation methods, see “Numerical calculation formula” (p. 216).

| Settings  |                |  |
|---|----------------|--|
| Syntax  | Command        | :CALCulate:MEAS:INTEgra no\$,A\$   |
| Example   |                | :CALCulate:MEAS:INTEgra NO1,TOTAL  |
| Query   |                |  |
| Syntax  | Query          | :CALCulate:MEAS:INTEgra? no\$  |
|   | Response       | no\$,A\$   |
| Example   |                | :CALCulate:MEAS:INTEgra? NO1<br>(Response) :CALCULATE:MEAS:INTEGRA NO1,TOTAL (When the header is ON)   |
| Parameter   |                |  |
| no\$ = NO1 to NO10<br>A\$ = TOTAL, POSitive, NEGative, ABSolute |                |  |
| TOTAL <sup>□</sup>  | Total          | Calculates the difference between the integrated value or area enclosed with the zero position and sections of the signal waveform with a positive amplitude and the integrated value or area enclosed with the zero position and sections of the signal waveform with a negative amplitude. |
| POSitive  | Positive       | Calculates the integrated value or area enclosed with the zero position and sections of the signal waveform with a positive amplitude.   |
| NEGative  | Negative       | Calculates the integrated value or area enclosed with the zero position and sections of the signal waveform with a negative amplitude.   |
| ABSolute  | Absolute value | Calculates the integrated value or area enclosed with the zero position and the signal waveform.   |

## 7 Check the numerical calculation results.

| Query   |          |  |
|---|----------|--|
| Syntax  | Query    | :CALCulate:MEAS:ANSWer? no\$,ch\$  |
|   | Response | no\$,ch\$,A<NR3> (11 digits after the decimal point)   |
| Example   |          | :CALCulate:MEAS:ANSWer? NO1,CH1_1<br>(Response) :CALCULATE:MEAS:ANSWER NO1,CH1_1,+1.23456789012E-03<br>(When the header is ON) |
| Parameter   |          |  |
| no\$ = NO1 to NO10<br>CH\$ = CH1_1 to CH10_30, PLS1, W1 to W30<br>A = Calculation result  |          |  |
| Under the following condition, A = NONE (character string) is returned.   |          |  |
| <ul style="list-style-type: none"> <li>• When the numerical calculation is set to OFF</li> <li>• When the numerical calculation type of the specified calculation number is set to OFF</li> <li>• When no calculation result exists or can be acquired</li> </ul> |          |  |

## Numerical calculation formula

The details of the numerical calculations are described here.

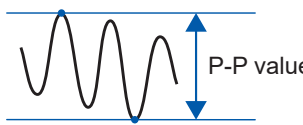
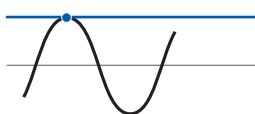
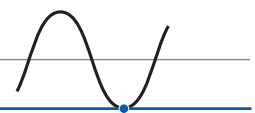
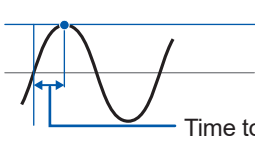
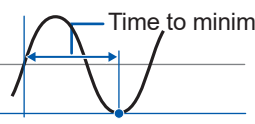
| Operation type                      | Description   |  |
|-------------------------------------|---|--|
| <b>Average</b>                      | Calculates the average of waveform data.<br>$AVE = \frac{1}{n} \sum_{i=1}^n di$ <i>AVE</i> : Average<br><i>n</i> : Number of data points<br><i>di</i> : <i>i</i> th data point in the channel                               |  |
| <b>P-P value</b>                    | Calculates the value between the maximum and minimum of waveform data (peak-to-peak value).   | Maximum <br>Minimum           |
| <b>Maximum</b>                      | Calculates the maximum of waveform data.  | Maximum                       |
| <b>Minimum</b>                      | Calculates the minimum of waveform data.  | Minimum                       |
| <b>Time to maximum</b>              | Calculates the time (s) to reach the maximum since the start of recording.* 1<br>If 2 or more points have the maximum value, the first point in the target waveform of the operation is treated as the maximum.             | Maximum <br>Time to maximum  |
| <b>Time to minimum</b>              | Calculates the time (s) to reach the minimum since the start of recording.* 1<br>If 2 or more points have the minimum value, the first point in the target waveform of the operation is treated as the minimum.             | Minimum <br>Time to minimum |
| <b>Aggregation (total)</b>          | Calculates the summation of the measurement data.<br>$SUM = \sum_{i=1}^n di$ <i>SUM</i> : Integrated value<br><i>n</i> : Total number of data<br><i>di</i> : <i>i</i> th data point in the channel                          |  |
| <b>Aggregation (positive)</b>       | Calculates the summation of the positive measurement data.<br>$SUM = \sum_{i=1, di > 0}^n di$ <i>SUM</i> : Integrated value<br><i>n</i> : Total number of data<br><i>di</i> : <i>i</i> th data point in the channel         |  |
| <b>Aggregation (negative)</b>       | Calculates the summation of the negative measurement data.<br>$SUM = \sum_{i=1, di < 0}^n di$ <i>SUM</i> : Integrated value<br><i>n</i> : Total number of data<br><i>di</i> : <i>i</i> th data point in the channel         |  |
| <b>Aggregation (absolute value)</b> | Calculates the summation of the absolute values of the measurement data.<br>$SUM = \sum_{i=1}^n  di $ <i>SUM</i> : Integrated value<br><i>n</i> : Total number of data<br><i>di</i> : <i>i</i> th data point in the channel |  |

\*1. When the trigger is used, the time from the trigger point is calculated.

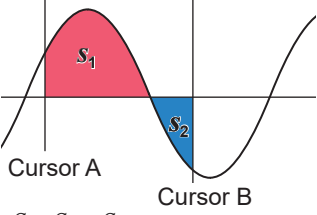
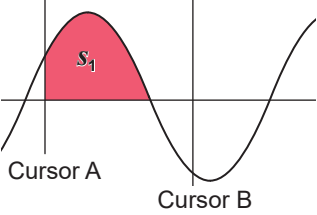
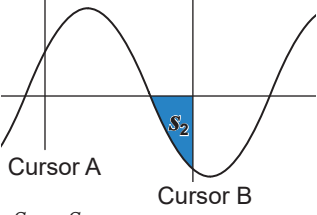
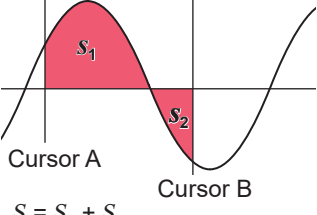

| Operation type                             | Description   |   |
|--|---|---|
| <p><b>Integration (total)</b></p>          | <p>Calculates the difference between the area (V·s) enclosed with the zero position (potential 0 V) and sections of the signal waveform with a positive amplitude and the area (V·s) enclosed with the zero position (potential 0 V) and sections of the signal waveform with a negative amplitude. If the operation is performed for a specified range (selected with A/B cursors), the aggregation between the cursors is calculated.</p> $S = \sum_{i=1}^n di \times \Delta t$ <p> <i>S</i>: Integral value<br/> <i>n</i>: Total number of data points<br/> <i>di</i>: <i>i</i>th data point in the channel<br/> <math>\Delta t</math>: Sampling period                 </p> |  <p>Cursor A                      Cursor B</p> <p><math>S = S_1 - S_2</math></p>   |
| <p><b>Integration (positive)</b></p>       | <p>Calculates the area (V·s) enclosed with the zero position (potential 0 V) and sections of the signal waveform with a positive amplitude. If the operation is performed for a specified range (selected with A/B cursors), the aggregation between the cursors is calculated.</p> $S = \sum_{i=1, di > 0}^n di \times \Delta t$ <p> <i>S</i>: Integral value<br/> <i>n</i>: Total number of data<br/> <i>di</i>: <i>i</i>th data point in the channel<br/> <math>\Delta t</math>: Sampling period                 </p>  | <p>Sections with a positive amplitude only</p>  <p>Cursor A                      Cursor B</p> <p><math>S = S_1</math></p>    |
| <p><b>Integration (negative)</b></p>       | <p>Calculates the area (V·s) enclosed with the zero position (potential 0 V) and sections of the signal waveform with a negative amplitude. If the operation is performed for a specified range (selected with A/B cursors), the aggregation between the cursors is calculated.</p> $S = \sum_{i=1, di < 0}^n di \times \Delta t$ <p> <i>S</i>: Integral value<br/> <i>n</i>: Total number of data<br/> <i>di</i>: <i>i</i>th data point in the channel<br/> <math>\Delta t</math>: Sampling period                 </p>  | <p>Sections with a negative amplitude only</p>  <p>Cursor A                      Cursor B</p> <p><math>S = -S_2</math></p> |
| <p><b>Integration (absolute value)</b></p> | <p>Calculates the area (V·s) enclosed with the zero position (potential 0 V) and the signal waveform. If the operation is performed for a specified range (selected with A/B cursors), the aggregation between the cursors is calculated.</p> $S = \sum_{i=1}^n  di  \times \Delta t$ <p> <i>S</i>: Integral value<br/> <i>n</i>: Total number of data<br/> <i>di</i>: <i>i</i>th data point in the channel<br/> <math>\Delta t</math>: Sampling period                 </p>  |  <p>Cursor A                      Cursor B</p> <p><math>S = S_1 + S_2</math></p>   |

## 9.2 Performing Waveform Calculations

The four arithmetic operations between the channels and other calculations including moving averaging can be performed (max. 30 calculations). The calculation types are the four arithmetic operations, aggregation, simple average, moving average, and integration. The calculations are performed in real time during the measurement, and the waveforms after the calculations are recorded. The waveform calculations cannot be performed after measurement. The waveform calculation results are recorded in calculation channel W1 to W30.

### 1 Enable the waveform calculation channel.

| Settings  |  |                        |
|---|--|------------------------|
| Syntax  | Command  | :MODule:STORe ch\$,A\$ |
| Example   | :MODule:STORe W1,ON  |                        |
| Query   |  |                        |
| Syntax  | Query  | :MODule:STORe?         |
|   | Response   | ch\$,A\$               |
| Example   | MODule:STORe? W1<br>(Response) :MODULE:STORE W1,ON (When the header is ON) |                        |
| Parameter   |  |                        |
| ch\$ = CH1_1 to CH10_30, PLS1, LOG, ALARM, W1 to W30<br>A\$ = OFF, ON |  |                        |

### 2 Set the waveform calculation type.

| Settings   |   |                              |
|--|---|------------------------------|
| Syntax   | Command   | :CALCulate:WAVE:KIND w\$,A\$ |
| Example  | :CALCulate:WAVE:KIND W1,OPE   |                              |
| Query  |   |                              |
| Syntax   | Query   | :CALCulate:WAVE:KIND? w\$    |
|  | Response  | w\$,A\$                      |
| Example  | :CALCulate:WAVE:KIND? W1<br>(Response) :CALCULATE:WAVE:KIND W1,OPE (When the header is ON)  |                              |
| Parameter  |   |                              |
| w\$ = W1 to W30<br>A\$ = OPE, SUM, AVE, MOV, INT |   |                              |
| OPE <sup>□</sup>                                 | Four arithmetic operations<br>Performs addition, subtraction, multiplication, and division between the channels.<br>Set the channels, coefficients, and constants. A constant can be set as an exponent.<br>If division by zero occurs during the calculation, the value of the quotient is set to 1.797693e+308. |                              |
| SUM  | Aggregation<br>Adds up the measurement data and records the summation.<br>Set the channels, start reset, and reset time.  |                              |
| AVE  | Simple average<br>Calculates the arithmetic mean of all measurement data since measurement is started and records the result.<br>Set the channels, start reset, and reset time.   |                              |
| MOV  | Moving average<br>Averages over the specified number of points while moving. The averaging is processed over the specified number of points in each sampling data, and the results are recorded.<br>Set the channels and the number of points.  |                              |
| INT  | Integration<br>Adds up the values of the measurement data multiplied by the sampling period and records the summation.<br>Set the channels, start reset, and reset time.  |                              |

### 3 (When the four arithmetic operations are selected for the waveform calculation type)

Set the constants, target channels, and operators that form the following formula.

(Formula) = (A \* CHa □ B \* CHb □ C \* CHc □ D \* CHd) ■ E

(1) A, B, C, D, and E: Any constant (p.220)

(2) CHa, CHb, CHc, and CHd: Any measurement channels (max. 4 channels) (p.219)

(3) □: One of the OFF, PLUS, MINUS, MULTI, and DIV operators. When OFF is selected, operators within the brackets after OFF are disabled. (p.220)

(4) ■: One of the OFF, PLUS, MINUS, MULTI, DIV, and EXP operators. When OFF is selected, the constant E is disabled. (p.220)

Example:

```
:CALCulate:WAVE:ARITHmetic:COEF:A W1,5
:CALCulate:WAVE:ARITHmetic:COEF:E W1,2
:CALCulate:WAVE:SOURce:SR1 W1,CH1_1
:CALCulate:WAVE:ARITHmetic:OPERator:A W1,OFF
:CALCulate:WAVE:ARITHmetic:OPERator:D W1,EXP
```

In this case,  
the formula is “(5 × CH<sub>1</sub>)<sup>2</sup>”.

The calculation channels can be selected as a target channel. However, the calculation channels with a larger number than the specified calculation channel cannot be selected. Example: For W5, W1 to W4 can be set as the calculation channels.

#### Waveform calculation source

Set CHa to CHd with the following commands.

| Settings  |  |  |
|---|--|--|
| Syntax  | Command  | :CALCulate:WAVE:SOURce:SR1 w\$,ch\$ (Measurement CHa)<br>:CALCulate:WAVE:SOURce:SR2 w\$,ch\$ (Measurement CHb)<br>:CALCulate:WAVE:SOURce:SR3 w\$,ch\$ (Measurement CHc)<br>:CALCulate:WAVE:SOURce:SR4 w\$,ch\$ (Measurement CHd) |
| Example   | :CALCulate:WAVE:SOURce:SR1 W1,CH1_1  |  |
| Query   |  |  |
| Syntax  | Query  | :CALCulate:WAVE:SOURce:SR1? w\$ (Measurement CHa)<br>:CALCulate:WAVE:SOURce:SR2? w\$ (Measurement CHb)<br>:CALCulate:WAVE:SOURce:SR3? w\$ (Measurement CHc)<br>:CALCulate:WAVE:SOURce:SR4? w\$ (Measurement CHd)                 |
|   | Response   | w\$,ch\$   |
| Example   | :CALCulate:WAVE:SOURce:SR1? W1<br>(Response) :CALCulate:WAVE:SOURce:SR1 W1,CH1_1 (When the header is ON) |  |
| Parameter   |  |  |
| w\$ = W1 to W30<br>ch\$ = CH1_1 to CH10_30, PLS1, W1 to W29 |  |  |

### Coefficients of the four arithmetic operations

| Settings   |   |   |
|--|---|---|
| <b>Syntax</b>                                    | Command   | :CALCulate:WAVE:ARITHmetic:COEF:A w\$,A (Coefficient A)<br>:CALCulate:WAVE:ARITHmetic:COEF:B w\$,A (Coefficient B)<br>:CALCulate:WAVE:ARITHmetic:COEF:C w\$,A (Coefficient C)<br>:CALCulate:WAVE:ARITHmetic:COEF:D w\$,A (Coefficient D)<br>:CALCulate:WAVE:ARITHmetic:COEF:E w\$,A (Coefficient E) |
| <b>Example</b>                                   | :CALCulate:WAVE:ARITHmetic:COEF:A W1,1  |   |
| Query  |   |   |
| <b>Syntax</b>                                    | Query   | :CALCulate:WAVE:ARITHmetic:COEF:A? w\$ (Coefficient A)<br>:CALCulate:WAVE:ARITHmetic:COEF:B? w\$ (Coefficient B)<br>:CALCulate:WAVE:ARITHmetic:COEF:C? w\$ (Coefficient C)<br>:CALCulate:WAVE:ARITHmetic:COEF:D? w\$ (Coefficient D)<br>:CALCulate:WAVE:ARITHmetic:COEF:E? w\$ (Coefficient E)      |
|  | Response  | w\$,A<NR3> (4 digits after the decimal point)   |
| <b>Example</b>                                   | :CALCulate:WAVE:ARITHmetic:COEF:A? W1<br>(Response) :CALCulate:WAVE:ARITHmetic:COEF:A W1,+1.0000E+00<br>(When the header is ON) |   |
| Parameter  |   |   |
| w\$ = W1 to W30<br>A = -9.9999E+29 to 9.9999E+29 |   |   |

### Operators of the four arithmetic operations

| Settings  |  |  |
|---|--|--|
| <b>Syntax</b>   | Command  | :CALCulate:WAVE:ARITHmetic:OPERator:A w\$,A\$ (Operator A)<br>:CALCulate:WAVE:ARITHmetic:OPERator:B w\$,A\$ (Operator B)<br>:CALCulate:WAVE:ARITHmetic:OPERator:C w\$,A\$ (Operator C)<br>:CALCulate:WAVE:ARITHmetic:OPERator:D w\$,A\$ (Operator D) |
| <b>Example</b>  | :CALCulate:WAVE:ARITHmetic:OPERator:A W1,PLUS  |  |
| Query   |  |  |
| <b>Syntax</b>   | Query  | :CALCulate:WAVE:ARITHmetic:OPERator:A? w\$ (Operator A)<br>:CALCulate:WAVE:ARITHmetic:OPERator:B? w\$ (Operator B)<br>:CALCulate:WAVE:ARITHmetic:OPERator:C? w\$ (Operator C)<br>:CALCulate:WAVE:ARITHmetic:OPERator:D? w\$ (Operator D)             |
|   | Response   | w\$,A\$  |
| <b>Example</b>  | :CALCulate:WAVE:ARITHmetic:OPERator:A? W1<br>(Response) :CALCulate:WAVE:ARITHmetic:OPERator:A W1,PLUS<br>(When the header is ON) |  |
| Parameter   |  |  |
| w\$ = W1 to W30<br>A\$ = OFF, PLUS, MINUS, MULTI, DIV (Operators A, B, C)<br>A\$ = OFF, PLUS, MINUS, MULTI, DIV, EXP (Operator D) |  |  |
| <b>OFF</b>  | The subsequent operations are not performed.   |  |
| <b>PLUS</b>   | Addition   |  |
| <b>MINUS</b>  | Subtraction  |  |
| <b>MULTI</b>  | Multiplication   |  |
| <b>DIV</b>  | Division   |  |
| <b>EXP</b>  | Exponentiation   |  |

**4** (When the waveform calculation type is set to Aggregation, Simple average, or Integration)  
Set the reset operation when measurement is started.

| Settings                           |   |                                    |
|------------------------------------|---|------------------------------------|
| Syntax                             | Command   | :CALCulate:WAVE:RESet:KIND w\$,A\$ |
| Example                            | :CALCulate:WAVE:RESet:KIND W1,OFF   |                                    |
| Query                              |   |                                    |
| Syntax                             | Query   | :CALCulate:WAVE:RESet:KIND? w\$    |
|                                    | Response  | w\$,A\$                            |
| Example                            | :CALCulate:WAVE:RESet:KIND? W1<br>(Response) :CALCulate:WAVE:MOVE:KIND W1,OFF (When the header is ON) |                                    |
| Parameter                          |   |                                    |
| w\$ = W1 to W30<br>A\$ = OFF, TRIG |   |                                    |
| OFF <sup>☐</sup>                   | Does not reset the calculation results.   |                                    |
| TRIG                               | Resets the calculation results when the trigger is activated.   |                                    |

**5** (When the waveform calculation type is set to Aggregation, Simple average, or Integration)  
Set the timing to perform the reset operation.

| Settings  |  |                                    |
|---|--|------------------------------------|
| Syntax  | Command  | :CALCulate:WAVE:RESet:TIME w\$,A\$ |
| Example   | :CALCulate:WAVE:RESet:TIME W1,OFF  |                                    |
| Query   |  |                                    |
| Syntax  | Query  | :CALCulate:WAVE:RESet:TIME? w\$    |
|   | Response   | w\$,A\$                            |
| Example   | :CALCulate:WAVE:RESet:TIME? W1<br>(Response) :CALCulate:WAVE:MOVE:TIME W1,OFF (When the header is ON)          |                                    |
| Parameter   |  |                                    |
| w\$ = W1 to W30<br>A\$ = OFF, ON, ONTIME                          |  |                                    |
| OFF <sup>☐</sup>  | Division disabled<br>Does not reset the calculation results.   |                                    |
| ON  | Division enabled<br>Resets the calculation results at the specified time intervals.                            |                                    |
| ONTIME  | Divided on time<br>Resets the calculation results at the specified intervals starting from the specified time. |                                    |
| When an external sampling is used, only OFF (Disable) can be set. |  |                                    |

## 6 Set the reference time and the reset interval.

(When the reset time is set to “division enabled”) Set the reset interval.

| Settings            |  |  |
|---------------------|--|--|
| Syntax              | Command  | :CALCulate:WAVE:RESet:INT w\$,day,hour,min |
| Example             | :CALCulate:WAVE:RESet:INT W1,0,0,1   |  |
| Query               |  |  |
| Syntax              | Query  | :CALCulate:WAVE:RESet:INT? w\$             |
|                     | Response   | w\$,day<NR1>,hour<NR1>,min<NR1>            |
| Example             | CALCulate:WAVE:RESet:INT? W1<br>(Response) :CALCULATE:WAVE:MOVE:INT W1,0,0,1 (When the header is ON) |  |
| Parameter           |  |  |
| w\$ = W1 to W30     |  |  |
| day                 | 0 to 30 (days)   |  |
| hour                | 0 to 23 (hours)  |  |
| min                 | 0 to 59 (minutes)  |  |
| Minimum of 1 minute |  |  |

(When the reset time is set to divided on time) Set the reference time and the reset interval.

| Settings        |  |   |
|-----------------|--|---|
| Syntax          | Command  | :CALCulate:WAVE:RESet:BASE w\$,hour,min |
| Example         | :CALCulate:WAVE:RESet:BASE W1,0,0  |   |
| Query           |  |   |
| Syntax          | Query  | :CALCulate:WAVE:RESet:BASE? w\$         |
|                 | Response   | w\$,hour<NR1>,min<NR1>                  |
| Example         | :CALCulate:WAVE:RESet:BASE? W1<br>(Response) :CALCULATE:WAVE:MOVE:POINT W1,0,0 (When the header is ON) |   |
| Parameter       |  |   |
| w\$ = W1 to W30 |  |   |
| hour            | 0 to 23 (hours)  |   |
| min             | 0 to 59 (minutes)  |   |

## 7 (When the waveform calculation type is set to moving average) Set the number of points.

| Settings                          |  |                                  |
|-----------------------------------|--|----------------------------------|
| Syntax                            | Command  | :CALCulate:WAVE:MOVE:POINT w\$,A |
| Example                           | :CALCulate:WAVE:MOVE:POINT W1,10   |                                  |
| Query                             |  |                                  |
| Syntax                            | Query  | :CALCulate:WAVE:MOVE:POINT? w\$  |
|                                   | Response   | w\$,A<NR1>                       |
| Example                           | :CALCulate:WAVE:MOVE:POINT? W11<br>(Response) :CALCULATE:WAVE:MOVE:POINT W1,10 (When the header is ON) |                                  |
| Parameter                         |  |                                  |
| w\$ = W1 to W30                   |  |                                  |
| A\$ = 1 to 600 (Number of points) |  |                                  |

## 8 Set the unit for waveform calculation.

See "(3) Character string data" (p. 24).

| Settings   |  |                                |
|--|--|--------------------------------|
| Syntax   | Command  | :CALCulate:WAVE:STR w\$, "A\$" |
| Example  | :CALCulate:WAVE:STR W1, "mA"   |                                |
| Query  |  |                                |
| Syntax   | Query  | :CALCulate:WAVE:STR? w\$       |
|  | Response   | w\$, "A\$"                     |
| Example  | :CALCulate:WAVE:STR? W1<br>(Response) :CALCULATE:WAVE:STR W1, "mA" (When the header is ON) |                                |
| Parameter  |  |                                |
| w\$ = W1 to W30<br>A\$ = Unit (up to 7 characters) |  |                                |





# 10 Setting System Environment

## 10.1 Setting the Environment

Set the various functions.

### Start backup

Set the operation when the power supply is restored.

When the parameter is set to ON, recording can be automatically resumed when the power supply is restored after the power is lost due to a power outage or other reasons during recording operation.

If the trigger is used, the instrument enters the trigger standby state.

If the measurement is resumed in the start hold status, the measurement data before the power failure stored in the internal buffer memory of the instrument is deleted.

| Settings                     |   |                   |
|------------------------------|---|-------------------|
| Syntax                       | Command   | :SYSTem:START A\$ |
| Example                      | :SYSTem:START ON  |                   |
| Query                        |   |                   |
| Syntax                       | Query   | :SYSTem:START?    |
|                              | Response  | A\$               |
| Example                      | :SYSTem:START?<br>(Response) :SYSTEM:START ON (When the header is ON) |                   |
| Parameter                    |   |                   |
| A\$ = OFF, ON                |   |                   |
| OFF <input type="checkbox"/> | Disables the start backup function.                                   |                   |
| ON <input type="checkbox"/>  | Enables the start backup function.                                    |                   |

## Language

This setting is not initialized. The default value varies depending on the shipping destination.

| Settings                |  |                      |
|-------------------------|--|----------------------|
| Syntax                  | Command  | :SYSTem:LANGuage A\$ |
| Example                 | :SYSTem:LANGuage ENGLISH   |                      |
| Query                   |  |                      |
| Syntax                  | Query  | :SYSTem:LANGuage?    |
|                         | Response   | A\$                  |
| Example                 | :SYSTem:LANGuage?<br>(Response) :SYSTEM:LANGUAGE ENGLISH (When the header is ON) |                      |
| Parameter               |  |                      |
| A\$ = JAPANese, ENGLISH |  |                      |
| JAPANese                | Japanese   |                      |
| ENGLISH                 | English  |                      |

## Date format

This setting is not initialized. The default value varies depending on the shipping destination.

| Settings                           |  |                     |
|------------------------------------|--|---------------------|
| Syntax                             | Command  | :SYSTem:DFOrmat A\$ |
| Example                            | :SYSTem:DFOrmat YYYYMMDD   |                     |
| Query                              |  |                     |
| Syntax                             | Query  | :SYSTem:DFOrmat?    |
|                                    | Response   | A\$                 |
| Example                            | :SYSTem:DFOrmat?<br>(Response) :SYSTEM:DIFORMAT YYYYMMDD (When the header is ON) |                     |
| Parameter                          |  |                     |
| A\$ = YYYYMMDD, MMDDYYYY, DDMMYYYY |  |                     |
| YYYYMMDD                           | yyyy MM dd   |                     |
| MMDDYYYY                           | MM dd yyyy   |                     |
| DDMMYYYY                           | dd MM yyyy   |                     |

The date format cannot be set during the measurement.

## Date delimiter

This setting is not initialized. The default value varies depending on the shipping destination.

| Settings                    |   |                        |
|-----------------------------|---|------------------------|
| Syntax                      | Command   | :SYSTem:DSEParator A\$ |
| Example                     | :SYSTem:DSEParator HYPHEN   |                        |
| Query                       |   |                        |
| Syntax                      | Query   | :SYSTem:DSEParator?    |
|                             | Response  | A\$                    |
| Example                     | :SYSTem:DSEParator?<br>(Response) :SYSTEM:DSEPARATOR HYPHEN (When the header is ON) |                        |
| Parameter                   |   |                        |
| A\$ = HYPHen, SLASH, PERiod |   |                        |
| HYPHen                      | Hyphen (-)  |                        |
| SLASH                       | Slash (/)   |                        |
| PERiod                      | Period (.)  |                        |

The date delimiter cannot be set during the measurement.

## Beep sound

Set whether or not to issue a beep sound when a warning occurs or a specific operation is performed.

| Settings        |   |                  |
|-----------------|---|------------------|
| Syntax          | Command   | :SYSTem:BEEP A\$ |
| Example         | :SYSTem:BEEP ON   |                  |
| Query           |   |                  |
| Syntax          | Query   | :SYSTem:BEEP?    |
|                 | Response  | A\$              |
| Example         | :SYSTem:BEEP?<br>(Response) :SYSTEM:BEEP ON (When the header is ON)                     |                  |
| Parameter       |   |                  |
| A\$ = OFF, ON   |   |                  |
| OFF             | Does not issue a beep sound when a warning occurs or a specific operation is performed. |                  |
| ON <sup>□</sup> | Issues a beep sound when a warning occurs or a specific operation is performed.         |                  |

A beep sound is issued if an error occurs under any condition.

## Horizontal (time) axis display

Set the horizontal axis display. This display is only available for the text format saving.

| Settings   |                       |   |
|--|-----------------------|---|
| Syntax   | Command               | :SYSTem:TMAXis A\$  |
| Example  |                       | :SYSTem:TMAXis TIME   |
| Query  |                       |   |
| Syntax   | Query                 | :SYSTem:TMAXis?   |
|  | Response              | A\$   |
| Example  |                       | :SYSTem:TMAXis?<br>(Response) :SYSTEM:TMAXIS TIME (When the header is ON) |
| Parameter  |                       |   |
| A\$ = TIME, DATE, SCALE  |                       |   |
| TIME   | Time                  |   |
| DATE   | Date                  |   |
| SCALE  | Number of data points |   |
| When an external sampling is used, only SCALE (Number of data) can be set. |                       |   |

## 10.2 Operating the System

You can correct the time and initialize the instrument (system reset).  
 You can run self-diagnosis (self-checks) on the instrument.

### Time setting

This instrument has a built-in auto-calendar, automatic leap year adjustment, and 24-hour clock.  
 The time is used for starting the measurement (start trigger time) and file information.

#### 1 Set the date and time of the instrument.

| Settings                                     |  |  |
|--|--|--|
| Syntax                                       | Command  | <code>:SYSTem:DATETime year,month,day,hour,minute,second</code>  |
| Example                                      | <code>:SYSTem:DATETime 23,1,2,12,34,56</code>  |  |
| Query on the date and time of the instrument |  |  |
| Syntax                                       | Query  | <code>:SYSTem:DATETime?</code>   |
|  | Response   | <code>year&lt;NR1&gt;,month&lt;NR1&gt;,day&lt;NR1&gt;hour&lt;NR1&gt;,<br/>minute&lt;NR1&gt;,second&lt;NR1&gt;</code> |
| Example                                      | <code>:SYSTem:DATETime?</code><br>(Response) <code>:SYSTEM:DATETIME 23,01,02,12,34,56</code> (When the header is ON) |  |
| Parameter                                    |  |  |
| <code>year</code>                            | 0 to 37 (year)   |  |
| <code>month</code>                           | 1 to 12 (month)  |  |
| <code>day</code>                             | 1 to 31 (days)   |  |
| <code>hour</code>                            | 0 to 23 (hours)  |  |
| <code>minute</code>                          | 0 to 59 (minutes)  |  |
| <code>second</code>                          | 0 to 59 (seconds)  |  |

The date and time of the instrument cannot be set during the measurement.  
 It takes approx. 1 second to set the date and time of the instrument.

#### 2 Set the date (year, month, day) of the instrument (if you wish to set the date without setting the time).

| Settings           |   |  |
|--------------------|---|--|
| Syntax             | Command   | <code>:SYSTem:DATE year,month,day</code>                     |
| Example            | <code>:SYSTem:DATE 20,1,2</code>  |  |
| Query              |   |  |
| Syntax             | Query   | <code>:SYSTem:DATE?</code>                                   |
|                    | Response  | <code>year&lt;NR1&gt;,month&lt;NR1&gt;,day&lt;NR1&gt;</code> |
| Example            | <code>:SYSTem:DATE?</code><br>(Response) <code>:SYSTEM:DATE 20,01,02</code> (When the header is ON) |  |
| Parameter          |   |  |
| <code>year</code>  | 00 to 37 (year)   |  |
| <code>month</code> | 01 to 12 (month)  |  |
| <code>day</code>   | 01 to 31 (days)   |  |

The time of the instrument cannot be set during the measurement.  
 It takes approx. 1 second to set the time of the instrument.

### 3 Set the time of the instrument (if you wish to set the time without setting the date: year, month, day).

| Settings  |   |                      |
|-----------|---|----------------------|
| Syntax    | Command   | :SYSTem:TIME h,m,s   |
| Example   | :SYSTem:TIME 12,34,56   |                      |
| Query     |   |                      |
| Syntax    | Query   | :SYSTem:TIME?        |
|           | Response  | h<NR1>,m<NR1>,s<NR1> |
| Example   | :SYSTem:TIME?<br>(Response) :SYSTEM:TIME 12,34,56 (When the header is ON) |                      |
| Parameter |   |                      |
| h         | 0 to 23 (hours)   |                      |
| m         | 0 to 59 (minutes)   |                      |
| s         | 0 to 59 (seconds)   |                      |

The time of the instrument cannot be set during the measurement.  
It takes approx. 1 second to set the time of the instrument.

### 4 Set the time zone.

This setting is not initialized. The default value varies depending on the shipping destination.

| Settings  |   |                             |
|-----------|---|-----------------------------|
| Syntax    | Command   | :SYSTem:TIMEZone hour(,min) |
| Example   | :SYSTem:TIMEZone 9  |                             |
| Query     |   |                             |
| Syntax    | Query   | :SYSTem:TIMEZone?           |
|           | Response  | hour<NR1>(,min<NR1>)        |
| Example   | :SYSTem:TIMEZone?<br>(Response) :SYSTEM:TIMEZone +9 (When the header is ON) |                             |
| Parameter |   |                             |
| hour      | -12 to +14 (hours)  |                             |
| min       | 30, 45 (min) (0 min when omitted)   |                             |

If the time zone is changed, the time of the clock is also changed accordingly.  
If the combination of hour and min cannot be set, an error will occur.

#### List of time zone

GMT+14, GMT+13, GMT+12:45, GMT+12, GMT+11, GMT+10:30,  
GMT+10, GMT+9:30, GMT+9, GMT+8:45, GMT+8, GMT+7,  
GMT+6:30, GMT+6, GMT+5:45, GMT+5:30, GMT+5, GMT+4:30,  
GMT+4, GMT+3:30, GMT+3, GMT+2, GMT+1, GMT, GMT-1, GMT-2,  
GMT-3, GMT-3:30, GMT-4, GMT-5, GMT-6, GMT-7, GMT-8,  
GMT-9, GMT-9:30, GMT-10, GMT-11, GMT-12



### Time zone

Set the time zone according to the region in which the instrument will be used.  
GMT stands for Greenwich Mean Time.

| Country (capital)                | Difference from standard time (Daylight-saving time) |
|----------------------------------|--|
| New Zealand (Wellington)         | GMT+12:00 (+13:00)                                   |
| Australia (Canberra)             | GMT+10:00 (+11:00)                                   |
| Japan (Tokyo)                    | GMT+9:00   |
| South Korea (Seoul)              | GMT+9:00   |
| China (Beijing)                  | GMT+8:00   |
| Taiwan (Taipei)                  | GMT+8:00   |
| Singapore (Singapore)            | GMT+8:00   |
| Mongol (Ulan Bator)              | GMT+8:00   |
| Indonesia (Jakarta)              | GMT+7:00   |
| Thailand (Bangkok)               | GMT+7:00   |
| India (New Delhi)                | GMT+5:30   |
| Pakistan (Islamabad)             | GMT+5:00   |
| United Arab Emirates (Abu Dhabi) | GMT+4:00   |
| Oman (Muscat)                    | GMT+4:00   |
| Iran (Tehran)                    | GMT+2:30 (+3:30)                                     |
| Romania (Bucharest)              | GMT+2:00 (+3:00)                                     |
| Finland (Helsinki)               | GMT+2:00 (+3:00)                                     |
| Qatar (Doha)                     | GMT+3:00   |
| Turkey (Ankara)                  | GMT+3:00   |
| Russia (Moscow)                  | GMT+3:00   |
| Israel (Jerusalem)               | GMT+3:00   |
| Ukraine (Kyiv)                   | GMT+2:00 (+3:00)                                     |

| Country (capital)           | Difference from standard time (Daylight-saving time) |
|-----------------------------|--|
| Greece (Athens)             | GMT+2:00 (+3:00)                                     |
| Germany (Berlin)            | GMT+1:00 (+2:00)                                     |
| France (Paris)              | GMT+1:00 (+2:00)                                     |
| The Netherlands (Amsterdam) | GMT+1:00 (+2:00)                                     |
| Italy (Rome)                | GMT+1:00 (+2:00)                                     |
| Poland (Warsaw)             | GMT+1:00 (+2:00)                                     |
| Switzerland (Bern)          | GMT+1:00 (+2:00)                                     |
| Czech Republic (Prague)     | GMT+1:00 (+2:00)                                     |
| Belgium (Brussels)          | GMT+1:00 (+2:00)                                     |
| Sweden (Stockholm)          | GMT+1:00 (+2:00)                                     |
| Denmark (Copenhagen)        | GMT+1:00 (+2:00)                                     |
| Norway (Oslo)               | GMT+1:00 (+2:00)                                     |
| Spain (Madrid)              | GMT+1:00 (+2:00)                                     |
| Hungary (Budapest)          | GMT+1:00 (+2:00)                                     |
| Austria (Vienna)            | GMT+1:00 (+2:00)                                     |
| Slovenia (Ljubljana)        | GMT+1:00 (+2:00)                                     |
| Egypt (Cairo)               | GMT+2:00   |
| South Africa (Pretoria)     | GMT+2:00   |
| U.K. (London)               | GMT(+1:00)   |
| Portugal (Lisbon)           | GMT(+1:00)   |
| U.S.A. (Washington D.C.)    | GMT-5:00 (-4:00)                                     |

As of October 2021

## Time synchronization

The clock of the instrument can be synchronized with an NTP server.  
It is necessary to configure the LAN setting in advance. (p.60)

### 1 Set the NTP client function.

| Settings         |   |                      |
|------------------|---|----------------------|
| Syntax           | Command   | :SYSTem:NTP:KIND A\$ |
| Example          | :SYSTem:NTP:KIND ON   |                      |
| Query            |   |                      |
| Syntax           | Query   | :SYSTem:NTP:KIND?    |
|                  | Response  | A\$                  |
| Example          | :SYSTem:NTP:KIND?<br>(Response) :SYSTEM:NTP:KIND ON (When the header is ON) |                      |
| Parameter        |   |                      |
| A\$ = OFF, ON    |   |                      |
| OFF <sup>☐</sup> | Disables the NTP client function  |                      |
| ON               | Enables the NTP client function   |                      |

### 2 Set the synchronization timing.

| Settings             |   |                      |
|----------------------|---|----------------------|
| Syntax               | Command   | :SYSTem:NTP:SYNC A\$ |
| Example              | :SYSTem:NTP:SYNC HOUR   |                      |
| Query                |   |                      |
| Syntax               | Query   | :SYSTem:NTP:SYNC?    |
|                      | Response  | A\$                  |
| Example              | :SYSTem:NTP:SYNC?<br>(Response) :SYSTEM:NTP:SYNC HOUR (When the header is ON) |                      |
| Parameter            |   |                      |
| A\$ = OFF, HOUR, DAY |   |                      |
| OFF <sup>☐</sup>     | Synchronization OFF   |                      |
| HOUR                 | Synchronization hourly  |                      |
| DAY                  | Synchronization daily   |                      |



### 3 Set the time synchronization before starting the measurement.

| Settings                                  |   |                                    |
|---|---|------------------------------------|
| Syntax                                    | Command   | <code>:SYSTem:NTP:START A\$</code> |
| Example                                   | <code>:SYSTem:NTP:START ON</code>   |                                    |
| Query                                     |   |                                    |
| Syntax                                    | Query   | <code>:SYSTem:NTP:START?</code>    |
|   | Response  | <code>A\$</code>                   |
| Example                                   | <code>:SYSTem:NTP:START?</code><br>(Response) <code>:SYSTEM:NTP:START ON</code> (When the header is ON) |                                    |
| Parameter                                 |   |                                    |
| <code>A\$</code> = OFF, ON                |   |                                    |
| <code>OFF</code> <input type="checkbox"/> | Disables the time synchronization before starting the measurement                                       |                                    |
| <code>ON</code> <input type="checkbox"/>  | Enables the time synchronization before starting the measurement  |                                    |

### 4 Set the destination server address.

| Settings  |   |  |
|---|---|--|
| Syntax  | Command   | <code>:SYSTem:NTP:ADDRess "A\$"</code> |
| Example   | <code>:SYSTem:NTP:ADDRess "abcdef.com"</code>   |  |
| Query   |   |  |
| Syntax  | Query   | <code>:SYSTem:NTP:ADDRess?</code>      |
|   | Response  | <code>"A\$"</code>                     |
| Example   | <code>:SYSTem:NTP:ADDRess?</code><br>(Response) <code>:SYSTEM:NTP:ADDRESS "abcdef.com"</code> (When the header is ON) |  |
| Parameter   |   |  |
| <code>A\$</code> = Destination server address (up to 64 single-byte characters) |   |  |

### 5 Execute the time synchronization and check the result.

| Query                                       |  |                                 |
|---|--|---------------------------------|
| Syntax                                      | Query  | <code>:SYSTem:NTP:CHECK?</code> |
|   | Response   | <code>A</code>                  |
| Example                                     | <code>:SYSTem:NTP:CHECK?</code><br>(Response) <code>:SYSTEM:NTP:CHECK 0</code> (When the header is ON) |                                 |
| Parameter                                   |  |                                 |
| <code>A\$</code> = 0 (success), 1 (failure) |  |                                 |



## Self-checks (Self-diagnosis)

You can perform self-checks (self-diagnosis) on the instrument. If an error is detected, contact your authorized Hioki distributor or reseller for repair.

### ROMRAM check

| Settings                    |   |   |
|-----------------------------|---|---|
| <b>Syntax</b>               | Command   | :SYSTem:CHECK:ROMRam<br>:SYSTem:CHECK   |
| <b>Example</b>              | :SYSTem:CHECK:ROMRam<br>:SYSTem:CHECK   |   |
| Query                       |   |   |
| <b>Syntax</b>               | Query   | :SYSTem:CHECK:ROMRam?<br>:SYSTem:CHECK? |
|                             | Response  | A\$                                     |
| <b>Example</b>              | :SYSTem:CHECK:ROMRam?<br>(Response) :SYSTEM:CHECK:ROMRAM PASS (When the header is ON) |   |
| Parameter                   |   |   |
| A\$ = NONE, RUN, PASS, FAIL |   |   |
| NONE                        | Not performed   |   |
| RUN                         | Running   |   |
| PASS                        | Normal  |   |
| FAIL                        | Error   |   |

It takes approx. 20 minutes to complete the ROMRAM check. Do not turn off the power during execution. During the ROMRAM check, the LEDs blink in sequence according to the progress.

### Module check

| Settings                  |   |                       |
|---------------------------|---|-----------------------|
| <b>Syntax</b>             | Command   | :SYSTem:CHECK:MODUle  |
| <b>Example</b>            | :SYSTem:CHECK:MODUle  |                       |
| Query                     |   |                       |
| <b>Syntax</b>             | Query   | :SYSTem:CHECK:MODUle? |
|                           | Response  | m1m2m3m4m5m6m7m8m9m10 |
| <b>Example</b>            | :SYSTem:CHECK:MODUle?<br>(Response) :SYSTEM:CHECK:MODULE 010101**** (When the header is ON) |                       |
| Parameter                 |   |                       |
| m1 to m10 = 0, 1, *, -, R |   |                       |
| 0                         | Success   |                       |
| 1                         | Failure   |                       |
| *                         | No module   |                       |
| -                         | No result   |                       |
| R                         | Running   |                       |

### Media check

| Settings                    |   |   |
|-----------------------------|---|---|
| Syntax                      | Command   | :SYSTem:CHECK:MEDiA:SD<br>:SYSTem:CHECK:MEDiA:USB   |
| Example                     | :SYSTem:CHECK:MEDiA:SD  |   |
| Query                       |   |   |
| Syntax                      | Query   | :SYSTem:CHECK:MEDiA:SD?<br>:SYSTem:CHECK:MEDiA:USB? |
|                             | Response  | A\$   |
| Example                     | :SYSTem:CHECK:MEDiA:SD?<br>(Response) :SYSTEM:CHECK:MEDIA:SD? 0 (When the header is ON) |   |
| Parameter                   |   |   |
| A\$ = NONE, RUN, PASS, FAIL |   |   |
| NONE                        | Not performed   |   |
| RUN                         | Running   |   |
| PASS                        | Normal  |   |
| FAIL                        | Error   |   |

### LAN1 check

| Settings  |  |                                       |
|---|--|---------------------------------------|
| Syntax  | Command  | :SYSTem:CHECK:IF:LAN1 ip1,ip2,ip3,ip4 |
| Example   | :SYSTem:CHECK:IF:LAN1 192,168,1,1  |                                       |
| Query   |  |                                       |
| Syntax  | Query  | :SYSTem:CHECK:IF:LAN1?                |
|   | Response   | A\$                                   |
| Example   | :SYSTem:CHECK:IF:LAN1?<br>(Response) :SYSTEM:CHECK:IF:LAN1? PASS (When the header is ON) |                                       |
| Parameter   |  |                                       |
| A\$ = NONE, RUN, PASS, FAIL   |  |                                       |
| NONE  | Not performed  |                                       |
| RUN   | Running  |                                       |
| PASS  | Normal   |                                       |
| FAIL  | Error  |                                       |
| ip1   | 0 to 255   |                                       |
| ip2   | 0 to 255   |                                       |
| ip3   | 0 to 255   |                                       |
| ip4   | 0 to255  |                                       |
| <p>As the instrument sends the PING command for checking the LAN, specify the IP of the LAN to which the PING command is to be sent.</p> <p>Specify the IP of the target LAN to which the PING command can be returned.</p> |  |                                       |

**LAN2 check (only LR8102)**

| Settings   |               |  |
|--|---------------|--|
| Syntax   | Command       | :SYSTem:CHECK:IF:LAN2 ip1,ip2,ip3,ip4  |
| Example  |               | :SYSTem:CHECK:IF:LAN2 192,168,1,1  |
| Query  |               |  |
| Syntax   | Query         | :SYSTem:CHECK:IF:LAN2?   |
|  | Response      | A\$  |
| Example  |               | :SYSTem:CHECK:IF:LAN2?<br>(Response) :SYSTEM:CHECK:IF:LAN2? PASS (When the header is ON) |
| Parameter  |               |  |
| A\$ = NONE, RUN, PASS, FAIL  |               |  |
| NONE   | Not performed |  |
| RUN  | Running       |  |
| PASS   | Normal        |  |
| FAIL   | Error         |  |
| ip1  | 0 to 255      |  |
| ip2  | 0 to 255      |  |
| ip3  | 0 to 255      |  |
| ip4  | 0 to 255      |  |
| <p>As the instrument sends the PING command for checking the LAN, specify the IP of the LAN to which the PING command is to be sent.<br/>Specify the IP of the target LAN to which the PING command can be returned.</p> |               |  |

## Operation clock checks

Check the operation clock.

**IMPORTANT**

The clock signal is output from the SMPL terminal.

As the operation clock setting is not backed up, the setting is turned OFF whenever the power is restored.

Checking the waveform of the output clock allows you to check for a time lag of the operation clock.

| Settings                 |  |  |
|--------------------------|--|--|
| Syntax                   | Command  | :SYSTem:CLOCK:OUT A\$  |
| Example                  |  | :SYSTem:CLOCK:OUT ON   |
| Query                    |  |  |
| Syntax                   | Query  | :SYSTem:CLOCK:OUT?   |
|                          | Response   | A\$  |
| Example                  |  | :SYSTem:CLOCK:OUT?<br>(Response) :SYSTEM:CLOCK:OUT? ON (When the header is ON) |
| Parameter                |  |  |
| A\$ = OFF, ON, PRECISION |  |  |
| OFF                      | Does not output the clock signal for checking from the SMPL terminal.            |  |
| ON                       | Outputs the clock signal for checking the clock accuracy from the SMPL terminal. |  |
| PRECISION                | Outputs the clock signal for checking the time accuracy from the SMPL terminal.  |  |

Check that the clock frequency output from the SMPL terminal is within the following range.

When ON is set: 32.768 kHz  $\pm$ 0.000379 kHz

When PRECISION is set: 10.000 kHz  $\pm$ 0.0000231 kHz

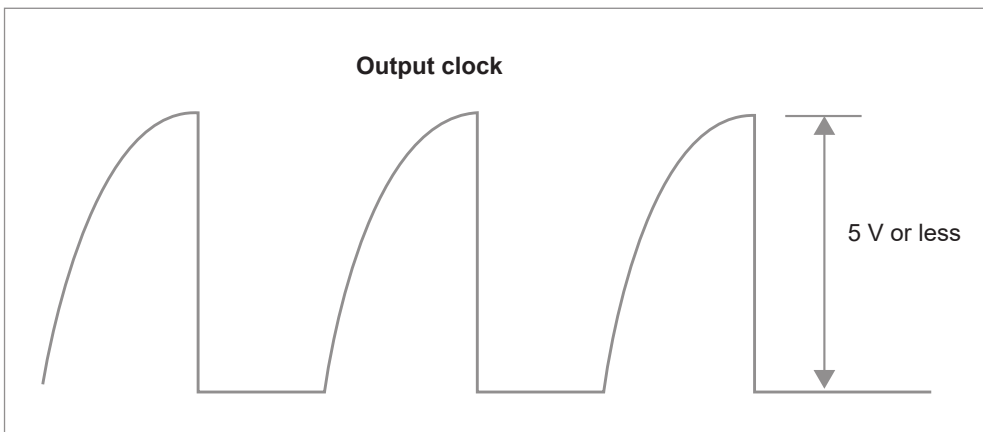

## Adjustment/calibration date checks

Check the adjustment date.

| Query  |   |   |
|--|---|---|
| <b>Syntax</b>  | Query   | <code>:SYSTem:ADJDate? A\$</code>                   |
|  | Response  | <code>Y&lt;NR1&gt;,M&lt;NR1&gt;,D&lt;NR1&gt;</code> |
| <b>Example</b>   | <code>:SYSTem:ADJDate? MODULE1</code><br>(Response) <code>:SYSTem:ADJDATE 23,12,22</code> (When the header is ON) |   |
| Parameter  |   |   |
| <b>A\$</b> = MAIN, MODULE1 to MODULE10   |   |   |
| <b>MAIN</b>  | Acquires the latest date (year, month, day) on which the instrument has been adjusted.                            |   |
| <b>MODULE1 to MODULE10</b>   | Acquires the latest date (year, month, day) on which the target module has been adjusted.                         |   |
| <b>Y</b>   | year  |   |
| <b>M</b>   | month   |   |
| <b>D</b>   | days  |   |
| If the target module does not exist, Y, M, and D are represented as <code>0,0,0</code> , respectively. |   |   |

Check the calibration date.

| Query  |   |   |
|--|---|---|
| <b>Syntax</b>  | Query   | <code>:SYSTem:CLBDate? A\$</code>                   |
|  | Response  | <code>Y&lt;NR1&gt;,M&lt;NR1&gt;,D&lt;NR1&gt;</code> |
| <b>Example</b>   | <code>:SYSTem:CLBDate? MODULE1</code><br>(Response) <code>:SYSTEM:CLBDATE 23,12,22</code> (When the header is ON) |   |
| Parameter  |   |   |
| <b>A\$</b> = MAIN, MODULE1 to MODULE10   |   |   |
| <b>MAIN</b>  | Acquires the latest date (year, month, day) on which the instrument has been calibrated.                          |   |
| <b>MODULE1 to MODULE10</b>   | Acquires the latest date (year, month, day) on which the target module has been calibrated.                       |   |
| <b>Y</b>   | year  |   |
| <b>M</b>   | month   |   |
| <b>D</b>   | days  |   |
| If the target module does not exist, Y, M, and D are represented as <code>0,0,0</code> , respectively. |   |   |





You can input signals to the external control terminal to control the instrument. The signals according to the instrument operations are output from the external control terminal. The external control terminal is not isolated (the ground is shared with the instrument). For connection to the external control terminal, see “Wiring for external control” (p. 49).

## 11.1 Setting the Alarm Output (ALARM)

Set the voltage level of the signal that is output when an alarm condition is met. For the alarms, see “7 Alarm (Alarm Output)” (p. 185).

Set the voltage level when an alarm is output.

| Settings                          |  |  |
|-----------------------------------|--|--|
| Syntax                            | Command  | <code>:ALARm:ACTive alm\$,A\$</code>   |
| Example                           |  | <code>:ALARm:ACTive ALM1,LOW</code>  |
| Query                             |  |  |
| Syntax                            | Query  | <code>:ALARm:ACTive? alm\$</code>  |
|                                   | Response   | <code>alm\$,A\$</code>   |
| Example                           |  | <code>:ALARm:ACTive? ALM1</code><br>(Response) <code>:TRIGGER:ACTIVE ALM1,LOW</code> (When the header is ON) |
| Parameter                         |  |  |
| <code>alm\$</code> = ALM1 to ALM4 |  |  |
| <code>A\$</code> = LOW, HIGH      |  |  |
| <code>LOW</code> <sup>□</sup>     | Outputs an alarm at a low level (0 V to 0.5 V).    |  |
| <code>HIGH</code>                 | Outputs an alarm at a high level (4.0 V to 5.0 V). |  |

### Specifications of the alarm output terminal

|                                   |  |
|-----------------------------------|--|
| <b>Output type</b>                | Open drain output (with 5 V voltage output)  |
| <b>Output voltage</b>             | High level: 4.0 V to 5.0 V, Low level: 0 V to 0.5 V<br>High and Low levels can be switched |
| <b>Output response time</b>       | Data refresh interval $\times 3 + 5$ ms  |
| <b>Maximum switching capacity</b> | 5 V to 10 V DC, 200 mA   |
| <b>Output pulse width</b>         | 10 ms or greater   |

### Circuit configuration diagram of an alarm output terminal and an example of connection with a relay

Select a relay with a contact configuration that enables the desired operations.

This connection example is a circuit configuration in which the relay is driven when the alarm output is Low.

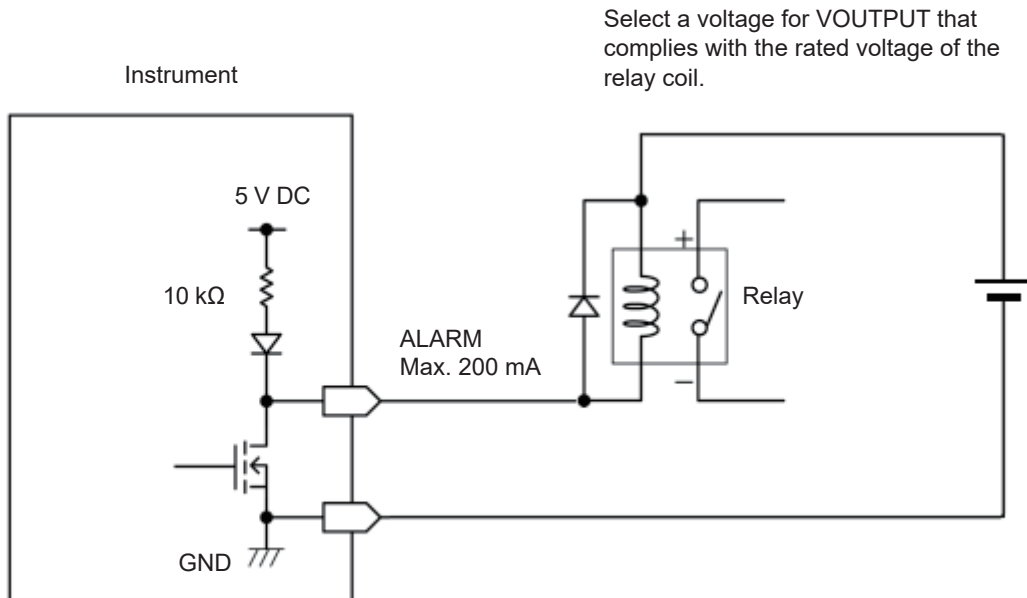

## 11.2 Setting the External Input and Output (I/O) Terminals

Set the functions of the external I/O terminals.

There are 4 external I/O terminals: I/O 1 to I/O 4.

You can control the measurement, such as starting and stopping the measurement and inputting the trigger signals.

I/O 1 to I/O 3 are the input terminals and I/O 4 is the output terminal.

### 1 Set the external input terminals.

| Settings  |  |  |
|---|--|--|
| <b>Syntax</b>   | Command  | :SYSTem:EXT:IO1:KIND A\$<br>:SYSTem:EXT:IO2:KIND A\$<br>:SYSTem:EXT:IO3:KIND A\$ |
| <b>Example</b>  | :SYSTem:EXT:IO1:KIND STARTIN   |  |
| Query   |  |  |
| <b>Syntax</b>   | Query  | :SYSTem:EXT:IO1:KIND?<br>:SYSTem:EXT:IO2:KIND?<br>:SYSTem:EXT:IO3:KIND?          |
|   | Response   | A\$  |
| <b>Example</b>  | :SYSTem:EXT:IO1:KIND?<br>(Response) :SYSTEM:EXT:IO1:KIND STARTIN (When the header is ON) |  |
| Parameter   |  |  |
| For external inputs 1 and 2<br>A\$ = OFF, STARTIN, STOPIN, S_SIN, EVENTIN |  |  |
| OFF <input type="checkbox"/>  | Disables the terminal.   |  |
| STARTIN   | Start<br>Starts measurement.   |  |
| STOPIN  | Stop<br>Stops measurement.   |  |
| S_SIN   | Start/stop<br>Starts or stops measurement based on changes in the signal level.          |  |
| EVENTIN   | Event input<br>Places an event mark.   |  |
| For external input 3<br>A\$ = OFF, TRIGIN, EVENTIN                        |  |  |
| OFF <input type="checkbox"/>  | Disables the external input.   |  |
| TRIGIN  | Trigger input<br>The trigger is activated.   |  |
| EVENTIN   | Event input<br>Places an event mark.   |  |

## 2 Set the edge.

### (1) Start slope

Set the slope to be used if the external input terminal is set to STARTIN, S\_SIN, TRIGIN, or EVENTIN.

| Settings          |   |   |
|-------------------|---|---|
| Syntax            | Command   | :SYSTem:EXT:IO1:SLOPe:START A\$<br>:SYSTem:EXT:IO2:SLOPe:START A\$<br>:SYSTem:EXT:IO3:SLOPe:START A\$ |
| Example           | :SYSTem:EXT:IO1:SLOPe:START UP  |   |
| Query             |   |   |
| Syntax            | Query   | :SYSTem:EXT:IO1:SLOPe:START?<br>:SYSTem:EXT:IO2:SLOPe:START?<br>:SYSTem:EXT:IO3:SLOPe:START?          |
|                   | Response  | A\$   |
| Example           | :SYSTem:EXT:IO1:SLOPe:START?<br>(Response) :SYSTEM:EXT:IO1:SLOPE:START UP (When the header is ON) |   |
| Parameter         |   |   |
| A\$ = UP, DOWN    |   |   |
| UP                | Operates at a rising edge from the Low to High level.   |   |
| DOWN <sup>☐</sup> | Operates at a falling edge from the High to Low level.  |   |

### (2) Stop slope

Set the slope to be used when the external input terminal is set to STOPIN or S\_SIN.

| Settings          |   |  |
|-------------------|---|--|
| Syntax            | Command   | :SYSTem:EXT:IO1:SLOPe:STOP A\$<br>:SYSTem:EXT:IO2:SLOPe:STOP A\$<br>:SYSTem:EXT:IO3:SLOPe:STOP A\$ |
| Example           | :SYSTem:EXT:IO1:SLOPe:STOP UP   |  |
| Query             |   |  |
| Syntax            | Query   | :SYSTem:EXT:IO1:SLOPe:STOP?<br>:SYSTem:EXT:IO2:SLOPe:STOP?<br>:SYSTem:EXT:IO3:SLOPe:STOP?          |
|                   | Response  | A\$  |
| Example           | :SYSTem:EXT:IO1:SLOPe:STOP?<br>(Response) :SYSTEM:EXT:IO1:SLOPE:STOP UP (When the header is ON) |  |
| Parameter         |   |  |
| A\$ = UP, DOWN    |   |  |
| UP                | Operates at a rising edge from the Low to High level.   |  |
| DOWN <sup>☐</sup> | Operates at a falling edge from the High to Low level.  |  |

**3** Set the functions of the external output terminal.

| Settings           |  |                          |
|--------------------|--|--------------------------|
| Syntax             | Command  | :SYSTem:EXT:IO4:KIND A\$ |
| Example            | :SYSTem:EXT:IO4:KIND TRIGOUT   |                          |
| Query              |  |                          |
| Syntax             | Query  | :SYSTem:EXT:IO4:KIND?    |
|                    | Response   | A\$                      |
| Example            | :SYSTem:EXT:IO4:KIND?<br>(Response) :SYSTEM:EXT:IO4:KIND TRIGOUT (When the header is ON) |                          |
| Parameter          |  |                          |
| A\$ = OFF, TRIGOUT |  |                          |
| OFF <sup>□</sup>   | Disables the terminal.   |                          |
| TRIGOUT            | Outputs a Low level signal when the trigger is activated.                                |                          |

### Input specifications of external input terminals (I/O 1, I/O 2, and I/O 3)

|                             |  |
|-----------------------------|--|
| <b>Input voltage</b>        | 0 V to 10 V DC<br>High level: 2.5 V to 10 V, Low level: 0 V to 0.8 V |
| <b>Slope</b>                | Rise or fall can be selected   |
| <b>Response pulse width</b> | High period 2.5 ms or greater, Low period 2.5 ms or greater          |

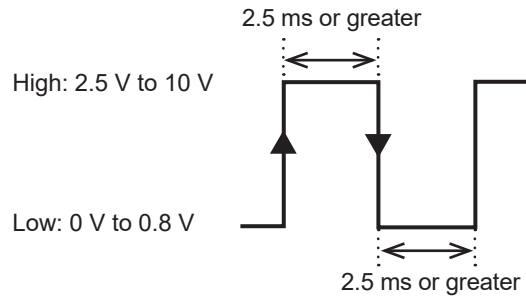
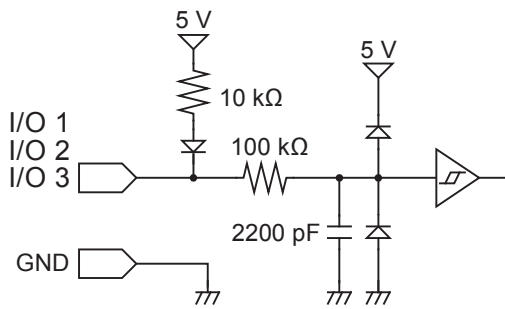

Operates at a rising edge or falling edge.  
(depending on the edge setting)

### Output specifications of external output terminal (I/O 4)

|                                   |   |
|-----------------------------------|---|
| <b>Output type</b>                | Open drain output (with 5 V voltage output)         |
| <b>Output voltage</b>             | High level: 4.0 V to 5.0 V, Low level: 0 V to 0.5 V |
| <b>Maximum switching capacity</b> | 5 V to 10 V DC, 200 mA                              |
| <b>Output pulse width</b>         | 10 ms or greater (trigger output)                   |

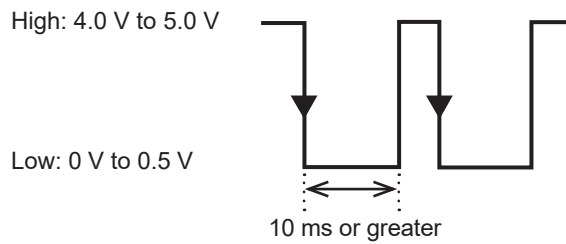
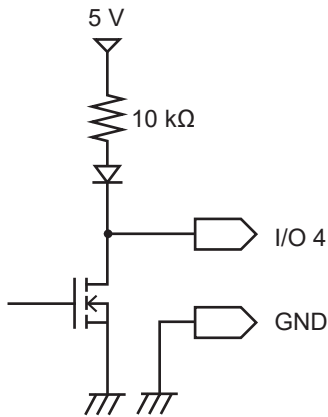

## Starting multiple measurements simultaneously using the external trigger

The start time of measurements on multiple units can be synchronized using the trigger input and output.

Since the sampling clock operates on each device, performing the measurement for a long time causes variation in the data acquisition time.

Use the synchronized input and output terminals to synchronize the sampling clocks as well. See “Set the synchronized terminal” (p. 89).

Methods for synchronizing the measurement start times are the daisy chain operation and parallel synchronized operation.

### Daisy chain operation

When the trigger is activated to any one of the devices, other devices are also triggered.

As the number of connected devices increases, variation in the trigger time among devices is increased.

|  |                                 |
|--|---------------------------------|
| <p><b>Connection method</b><br/>Connect the “trigger output (I/O 4)” on one device with the “trigger input (I/O 3)” on the next device.<br/>Repeat this connection in turn until all devices are connected.</p> <p><b>Setting method</b></p> <ul style="list-style-type: none"> <li>• Enable the trigger function on all devices (p. 139)</li> <li>• Enable the external trigger function on all devices (p. 153)</li> <li>• Set I/O 3 to the trigger input on all devices, and set the edge to <b>DOWN</b> (p. 244)</li> <li>• Set the external output to <b>TRIGOUT</b> on all devices (p. 245)</li> </ul> | <p><b>Connection method</b></p> |
|--|---------------------------------|

### Parallel synchronized operation

Set one device as the primary unit (for trigger monitoring) and set other devices as the secondary units.

If the trigger is activated to the primary unit, the secondary units are also triggered.

Even if the number of connected devices increases, variation in the trigger time among devices is minimal.

|   |                                 |
|---|---------------------------------|
| <p><b>Connection method</b><br/>Connect the “trigger output (I/O 4)” on the primary unit with the “trigger input (I/O 3)” on all secondary units.</p> <p><b>Setting method</b></p> <ul style="list-style-type: none"> <li>• Enable the trigger function on all devices (p. 139)</li> <li>• Enable the external trigger function on all secondary units (p. 153)</li> <li>• Set I/O 3 to the trigger input on the secondary units, and set the edge to <b>DOWN</b> (p. 244)</li> <li>• Set the external output to <b>TRIGOUT</b> on the primary unit (p. 245)</li> </ul> | <p><b>Connection method</b></p> |
|---|---------------------------------|

## 11.3 Setting the External Sampling (SMPL)

Noise immunity can be improved by setting a filter on the external sampling terminal. See “External sampling” (p. 85).

### 1 Set the filter.

| Settings        |   |                       |
|-----------------|---|-----------------------|
| Syntax          | Command   | :SYSTem:EXTFILTer A\$ |
| Example         | :SYSTem:EXTFILTer ON  |                       |
| Query           |   |                       |
| Syntax          | Query   | :SYSTem:EXTFILTer?    |
|                 | Response  | A\$                   |
| Example         | :SYSTem:EXTFILTer?<br>(Response) :SYSTEM:EXTFILTER ON (When the header is ON) |                       |
| Parameter       |   |                       |
| A\$ = OFF, ON   |   |                       |
| OFF             | Disables the filter.  |                       |
| ON <sup>□</sup> | Enables the filter.   |                       |

### 2 Set the slope.

| Settings          |   |                      |
|-------------------|---|----------------------|
| Syntax            | Command   | :SYSTem:EXTSLOPe A\$ |
| Example           | :SYSTem:EXTSLOPe UP   |                      |
| Query             |   |                      |
| Syntax            | Query   | :SYSTem:EXTSLOPe?    |
|                   | Response  | A\$                  |
| Example           | :SYSTem:EXTSLOPe?<br>(Response) :SYSTEM:EXTSLOPE UP (When the header is ON) |                      |
| Parameter         |   |                      |
| A\$ = UP, DOWN    |   |                      |
| UP                | Operates at a rising edge from the Low to High level.                       |                      |
| DOWN <sup>□</sup> | Operates at a falling edge from the High to Low level.                      |                      |



## Communication functions with a PC that cannot be used concurrently (LAN1)

There are the following restrictions concerning the communication function with a PC.

| Description  | Communication functions that cannot be used concurrently   | See   |
|--|--|-------|
| Realtime data acquisition with communication commands* <sup>1</sup> (measurement with a program in Visual Basic, etc.) | • Realtime measurement with Logger Utility   | –     |
| Realtime measurement with Logger Utility   | • Realtime data acquisition using a communication command<br>• Auto data sending using the FTP client function | p.249 |
| Simple remote operation using the HTTP server function   | • Realtime data acquisition using a communication command<br>• Realtime measurement with Logger Utility        | p.251 |
| Data acquisition using the FTP server function   | –  | p.262 |
| Auto data sending using the FTP client function  | • Realtime measurement with Logger Utility   | p.264 |

\*1. There are restrictions when acquiring realtime data using a communication command.  
See “4.7 Comparison of Realtime Data Acquisition” (p. 136).

## 12.1 Using Logger Utility

Application software “Logger Utility” is provided with the instrument.

Using a PC installed with Logger Utility, you can perform the settings and operations of the instrument and waveform observation.

The PC is connected with the instrument using LAN1.

The advantages are as follows:

- Data can be collected in real time on the PC and waveforms and numerical values can be checked immediately.
- The measurement data can be analyzed.
- The measurement data can be converted (from the binary format to the CSV format).
- Waveform data can be transferred in real time to an Excel file running on the PC.
- Not only the instrument, but also up to 5 units and 600 channels can be operated including existing loggers.

### Models supporting Logger Utility

LR8101, LR8102, LR8450, LR8450-01, LR8400, LR8401, LR8402, LR8410, LR8416, LR8431, LR8432, 8423

For how to install and operate the PC application software, “Logger Utility”, refer to “Logger Utility Instruction Manual” found on the provided DVD (Application Disc).



When the recording interval is 5 ms, realtime data cannot be collected. Also, when the number of analog channels for measurement ON is 601 or more, realtime data cannot be collected.

As values are handled differently between the instrument and Logger Utility, the numerical calculation result and waveform calculation result may differ in the following cases.

- When the result significantly exceeds the allowable measurement range (+OVER, -OVER)
- When a thermocouple wire break is detected during temperature measurement (burnout detection)
- When no measurement data exists (NO DATA)

## 12.2 Remotely Operating the Instrument through the HTTP Server

The instrument can be remotely operated with a PC using the HTTP server function.

You can set the instrument, check the measurement data, etc., using a standard browser, such as Microsoft Edge.

The LAN setting and connection are required to remotely operate the instrument through the HTTP server.

When the HTTP server is accessed, the header is set to OFF in the communication command setting. During measurement with Logger Utility or a program in Visual Basic, etc., the remote operations through the HTTP server are disabled.

After the instrument is upgraded, the page of the previous version may open and the operations may not be performed properly. In this case, clear the browser's cache and connect to the HTTP server again.

When you set the clock of the instrument while connecting the HTTP server, the communication may be cut off.

12

Communication with PC (Computer)

### Connecting to the HTTP server

Connect a PC to the HTTP server.

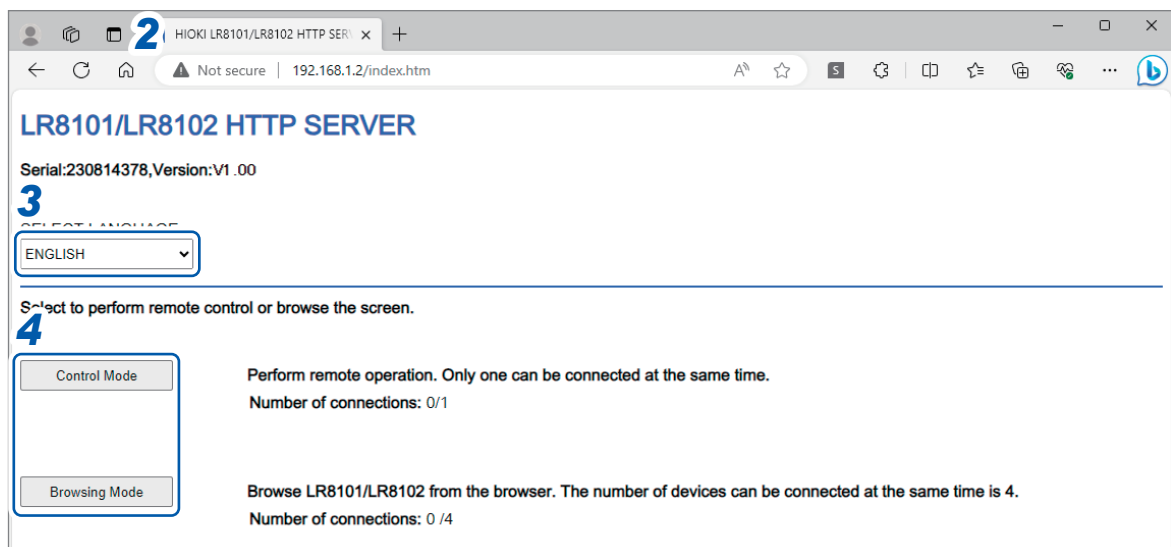

- 1** Open a browser on the PC.
- 2** Enter the instrument's address in the address bar. (Example: <http://192.168.1.2>)  
Microsoft Edge is a recommended browser.
- 3** Set the language (as needed).

JAPANESE, ENGLISH

- 4** Select the mode.

|                     |  |
|---------------------|--|
| <b>Control Mode</b> | Allows you to control and set the instrument from a browser.<br>Only one unit can be connected at the same time.     |
| <b>View Mode</b>    | Allows you to only view the screen and status from a browser.<br>Up to four units can be connected at the same time. |

## When the HTTP screen displays nothing

Perform the following operations and then check whether the LAN communications can be established.

See “When the LAN communications cannot be established.” (p. 75).

### Windows 7 or Windows 8

- 1** Open [Control Panel] and click [Network and Internet] > [Internet Options].
- 2** In the [Advanced] tab, enable [Use HTTP 1.1] and disable [Use HTTP 1.1 through proxy connections].
- 3** In [LAN settings] in the [Connections] tab, disable the [Proxy server] setting.

### Windows 10 or Windows 11

- 1** Open [Settings] in Windows and click [Network & internet] > [Proxy].
- 2** If [Manual proxy setup] > [Use a proxy server] is [On], turn it [Off].  
If this is [On], the communications may not be established properly.

## Starting and stopping measurement

You can use a browser to start and stop measurement.

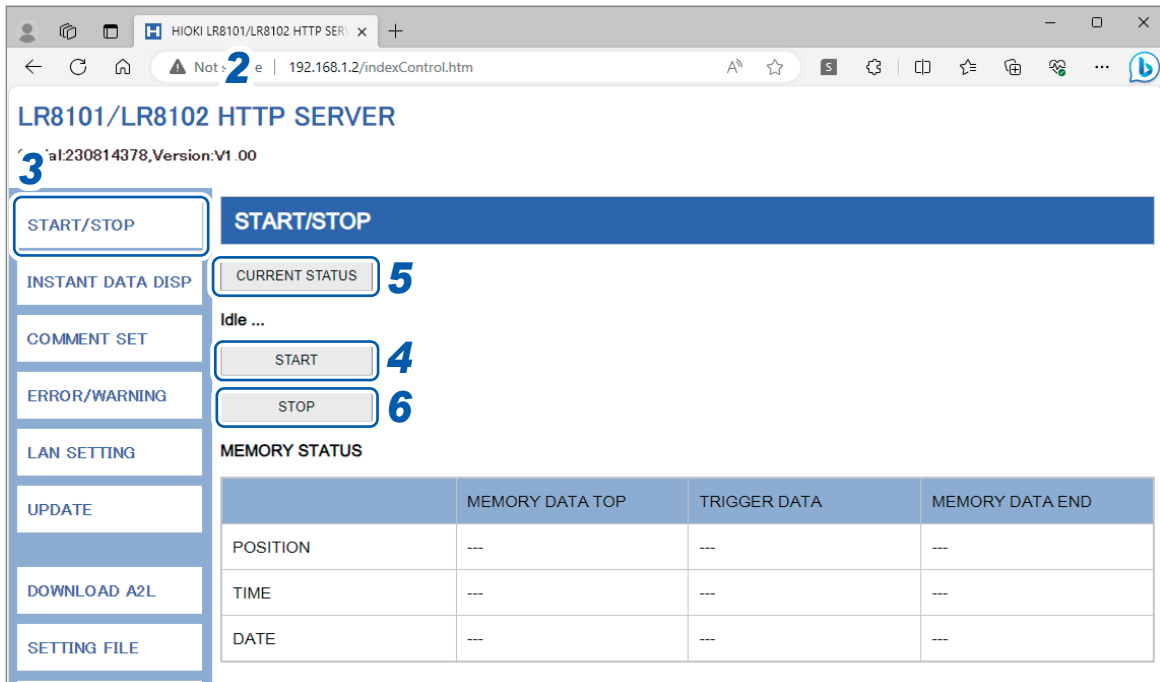

- 1** Open a browser on the PC.
- 2** Enter the instrument's address in the address bar. (Example: `http://192.168.1.2`)
- 3** Click **[START/STOP]**.  
The **[START/STOP]** screen is displayed.
- 4** Click **[START]**.  
Starts measurement.
- 5** Click **[CURRENT STATUS]** (as needed).  
Displays the measurement status of the instrument.
- 6** Click **[STOP]**.  
Stops measurement.

## Displaying the measured value

You can use a browser to check the current measured value.

The screenshot shows the 'LR8101/LR8102 HTTP SERVER' web interface. The browser address bar shows 'http://192.168.1.2/indexControl.htm'. The page title is 'LR8101/LR8102 HTTP SERVER' and the serial number is 'Serial230814378,Version:V1.00'. The main content area is titled 'INSTANT DATA DISP'. On the left, there is a sidebar with buttons for 'PART/STOP', 'INSTANT DATA DISP', 'COMMENT SET', 'ERROR/WARNING', 'LAN SETTING', 'UPDATE', 'DOWNLOAD A2L', 'SETTING FILE', 'MANUAL', and 'MAIN PAGE'. The 'INSTANT DATA DISP' section includes a 'SELECT MODULE' dropdown menu set to 'MODULE1:M7100' and a 'REFRESH INTERVAL' dropdown menu set to '1 s'. Below these is a table displaying measured values for 15 channels (M1\_1 to M1\_15). The table has columns for 'Ch', 'Data', and 'Comment'. The 'Data' column contains values in scientific notation, such as +1.232600E-03V for M1\_1 and -4.245300E-03V for M1\_15. The 'Comment' column is empty for all channels.

| Ch    | Data           | Comment | Ch    | Data           | Comment |
|-------|----------------|---------|-------|----------------|---------|
| M1_1  | +1.232600E-03V |         | M1_2  | -1.173800E-03V |         |
| M1_3  | -2.732600E-03V |         | M1_4  | -1.774000E-03V |         |
| M1_5  | -3.166900E-03V |         | M1_6  | -2.520100E-03V |         |
| M1_7  | -3.006300E-03V |         | M1_8  | -3.151000E-03V |         |
| M1_9  | -2.615600E-03V |         | M1_10 | -2.788200E-03V |         |
| M1_11 | -3.497100E-03V |         | M1_12 | -3.169200E-03V |         |
| M1_13 | -3.939100E-03V |         | M1_14 | -3.632500E-03V |         |
| M1_15 | -4.245300E-03V |         |       |                |         |

- 1** Open a browser on the PC.
- 2** Enter the instrument's address in the address bar. (Example: <http://192.168.1.2>)
- 3** Click **[INSTANT DATA DISP]**.  
Displays the current measured value.
- 4** Set the module to display the value with **[SELECT MODULE]**.  
Displays the measured value in each channel of the selected module.
  - It can take 2 or 3 seconds to acquire data depending on the communication status.
  - If the display is set to OFF for a channel, its value is not displayed.
  - While measurement is stopped, the instant data that is input to each channel is displayed.
- 5** Set the screen refresh time with **[REFRESH INTERVAL]**.

OFF , 1 s, 5 s, 10 s, 30 s

## Comment entry

You can use a browser to enter a title comment and channel comments.

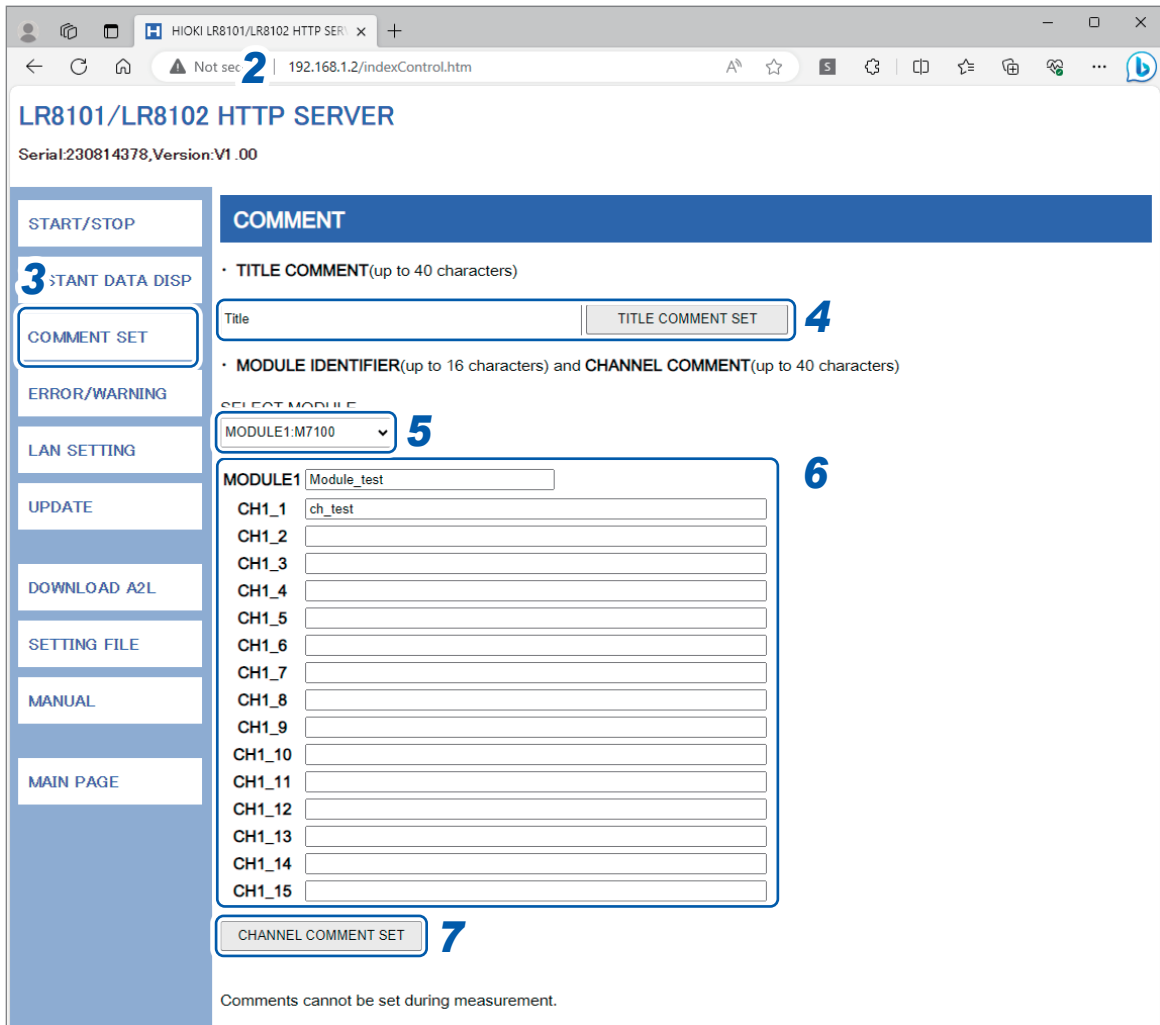

- 1** Open a browser on the PC.
- 2** Enter the instrument's address in the address bar. (Example: **http://192.168.1.2**)
- 3** Click **[COMMENT SET]**.  
Displays the comments that have been input to the instrument.
- 4** Enter a title comment and then click **[TITLE COMMENT SET]**.  
The title comment on the instrument is updated with the entry.
- 5** Set the module to display the comment.  
Displays the module identification name and channel comment for the selected module.
- 6** Enter a module identification name and comment for each channel.
- 7** Click **[CHANNEL COMMENT SET]**.  
The module identification names and channel comments on the instrument are updated with the entries.  
The comments on the instrument cannot be changed during the measurement.

## Error/warning display

You can use a browser to check the errors and warnings.

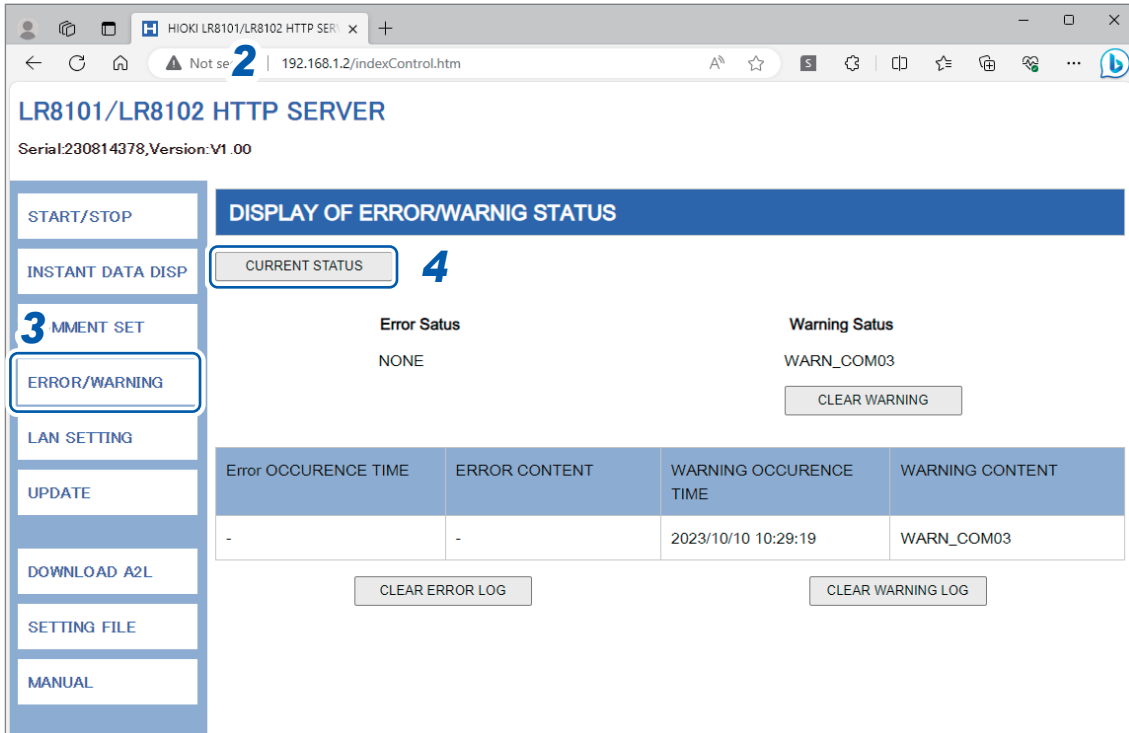

- 1 Open a browser on the PC.
- 2 Enter the instrument's address in the address bar. (Example: <http://192.168.1.2>)
- 3 Click [\[ERROR/WARNING\]](#).
- 4 Click [\[CURRENT STATUS\]](#).

The displayed error and warning information is updated.

| Display   | Description   | See    |
|---|---|--------|
| <b>Error Status</b>                               | Current error status of the instrument  | p. 352 |
| <b>Warning Status</b>                             | Current warning status of the instrument<br>Clicking <a href="#">[CLEAR WARNING]</a> clears the description of the log. | p. 353 |
| <b>ERROR OCCURENCE TIME<br/>ERROR CONTENT</b>     | 50 latest error logs<br>Clicking <a href="#">[CLEAR ERROR LOG]</a> clears the description of the log.                   | -      |
| <b>WARNING OCCURENCE TIME<br/>WARNING CONTENT</b> | 50 latest warning logs<br>Clicking <a href="#">[CLEAR WARNING LOG]</a> clears the description of the log.               | -      |



## LAN settings

You can use a browser to set a LAN.

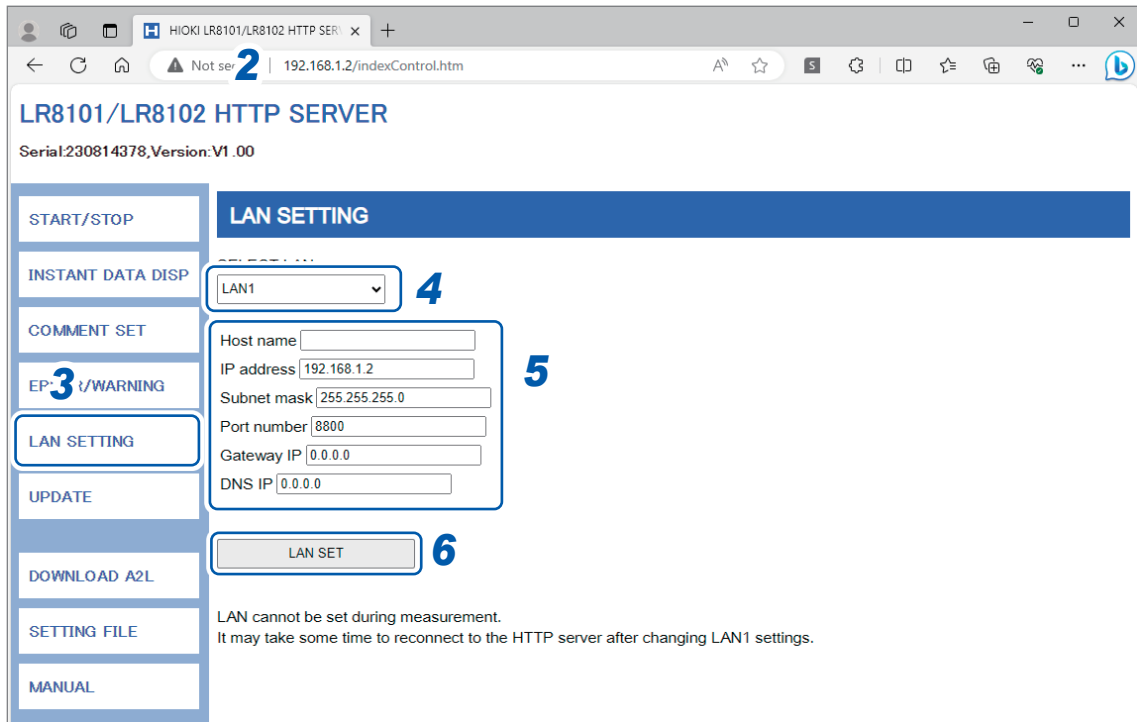

- 1** Open a browser on the PC.
- 2** Enter the instrument's address in the address bar. (Example: <http://192.168.1.2>)
- 3** Click **[LAN SETTING]**.
- 4** Select the type of LAN for which the settings are to be changed.
- 5** Enter the LAN settings.
- 6** Click **[LAN SET]**.

After the LAN1 settings have been changed, the HTTP server is disconnected. Wait for a while, and then reconnect to the server.

## Remote upgrade

You can use a browser to upgrade the instrument and modules.

You can also check the models, serial numbers, and versions of the instrument and modules, as well as the FPGA versions of the modules.

When an upgrade is required, the upgrader file and procedures are released on the Hioki website.

When performing remote upgrade, download the file from the Hioki website and extract it in advance. (Be sure not to change the file name.)

No SD memory card or USB drive is required.

The screenshot shows the 'LR8101/LR8102 HTTP SERVER' interface. The title bar indicates the URL is '192.168.1.2/indexControl.htm'. The page header shows 'Serial:230814378,Version:V1.00'. The left sidebar has a '3' next to 'SETTING' and a red box around the 'UPDATE' button. The main content area has a red box around the 'UPDATE' button and another red box around the 'Choose File' button. A progress bar shows 0% completion. Below the progress bar is a table with the following data:

| Module No. | Model  | Serial No. | Version | FPGA Version |
|------------|--------|------------|---------|--------------|
| HIOKI      | LR8102 | 230814378  | V1.00   |              |
| MODULE1    | M7100  |            | V100    | V100         |
| MODULE2    | M7102  |            | V100    | V100         |
| -          | -      | -          | -       | -            |
| -          | -      | -          | -       | -            |
| -          | -      | -          | -       | -            |
| -          | -      | -          | -       | -            |
| -          | -      | -          | -       | -            |
| -          | -      | -          | -       | -            |
| -          | -      | -          | -       | -            |
| -          | -      | -          | -       | -            |

- 1 Open a browser on the PC.
- 2 Enter the instrument's address in the address bar. (Example: <http://192.168.1.2>)
- 3 Click [\[UPDATE\]](#).
- 4 Click [\[Choose File\]](#) and select the downloaded upgrader file (extensions: [\[UPG\]](#) for the instrument, [\[PRG\]](#) for the modules).
- 5 Click [\[UPDATE\]](#).

The instrument is automatically restarted after the upgrade. The communications are shut down at that time.

For other precautions and checks after the upgrade, refer to the procedures.

## Downloading A2L file

You can use a browser to download the A2L file.

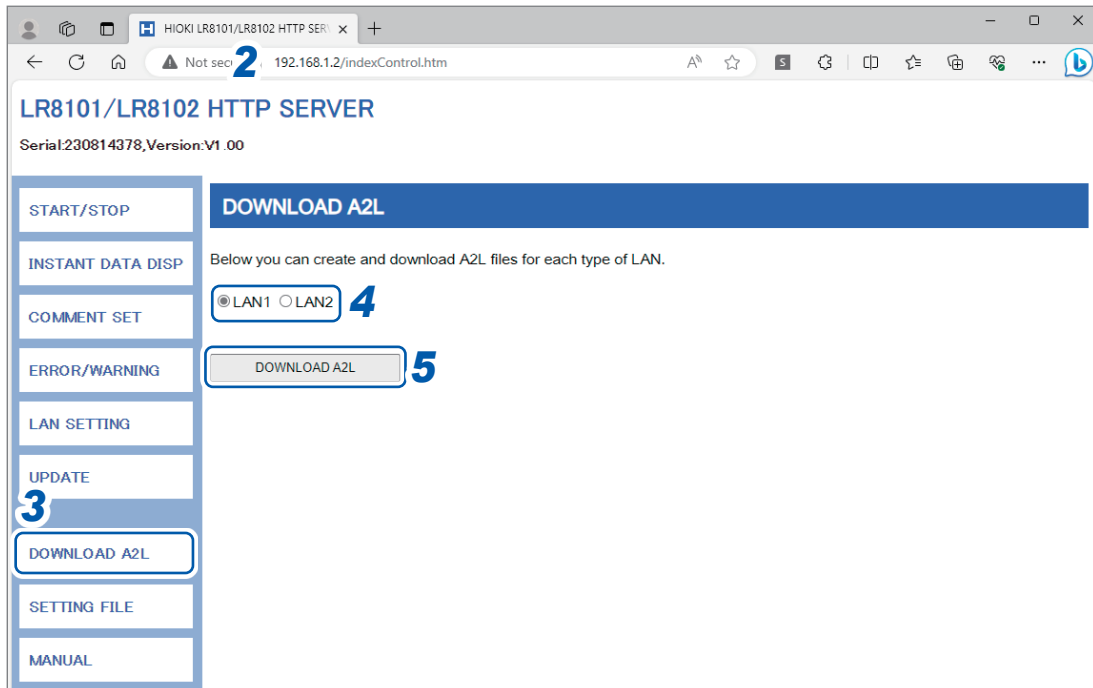

- 1** Open a browser on the PC.
- 2** Enter the instrument's address in the address bar. (Example: `http://192.168.1.2`)
- 3** Click **[DOWNLOAD A2L]**.
- 4** Select the LAN to be connected to the XCP.
- 5** Click **[DOWNLOAD A2L]**.

## Acquisition of setting file information

You can use a browser to acquire the setting file information.

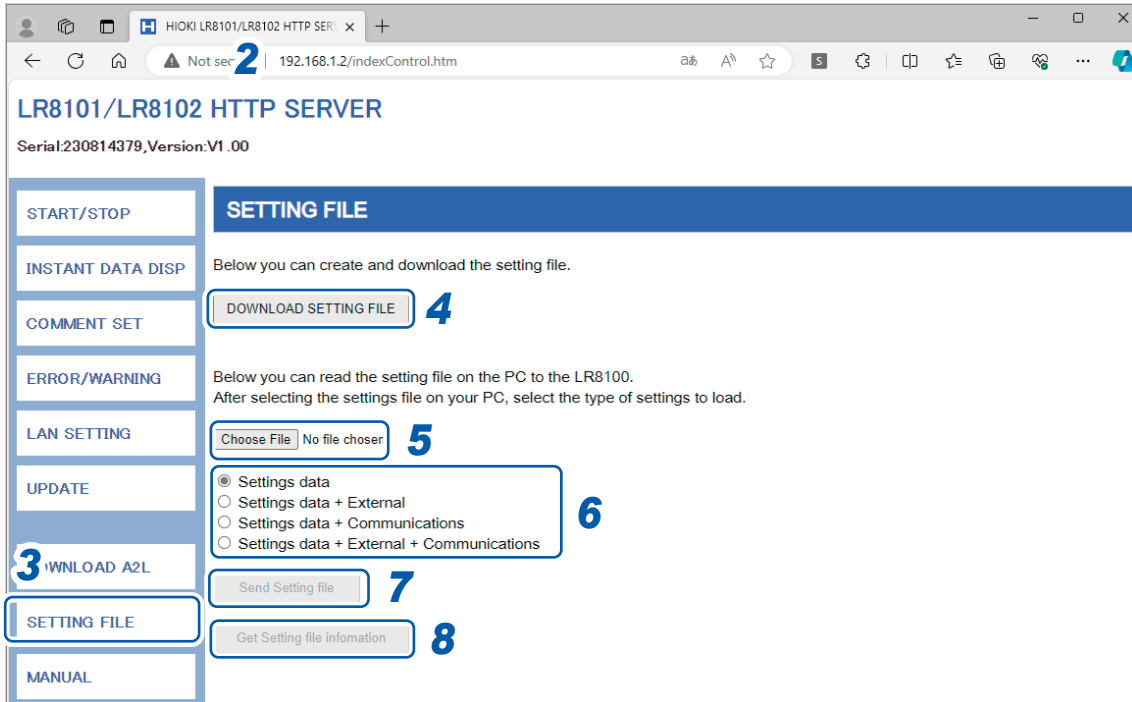

- 1 Open a browser on the PC.
- 2 Enter the instrument's address in the address bar. (Example: <http://192.168.1.2>)
- 3 Click [SETTING FILE].
- 4 Click [DOWNLOAD SETTING FILE].  
Download the current settings of the instrument.
- 5 Click [Choose File], and then select the setting file on the PC you want to load into the instrument.
- 6 Select the settings to be loaded into the instrument.

Setting data, Settings data + External, Settings data + Communications, Settings data + External+ Communications

- 7 Click [Send Setting file].  
The current settings are updated with the setting selected in step 6.
- 8 Click [Get Setting file information].  
The module configuration of the setting file is acquired.

## Downloading Instruction Manual

You can use a browser to download the Instruction Manual for the instrument.

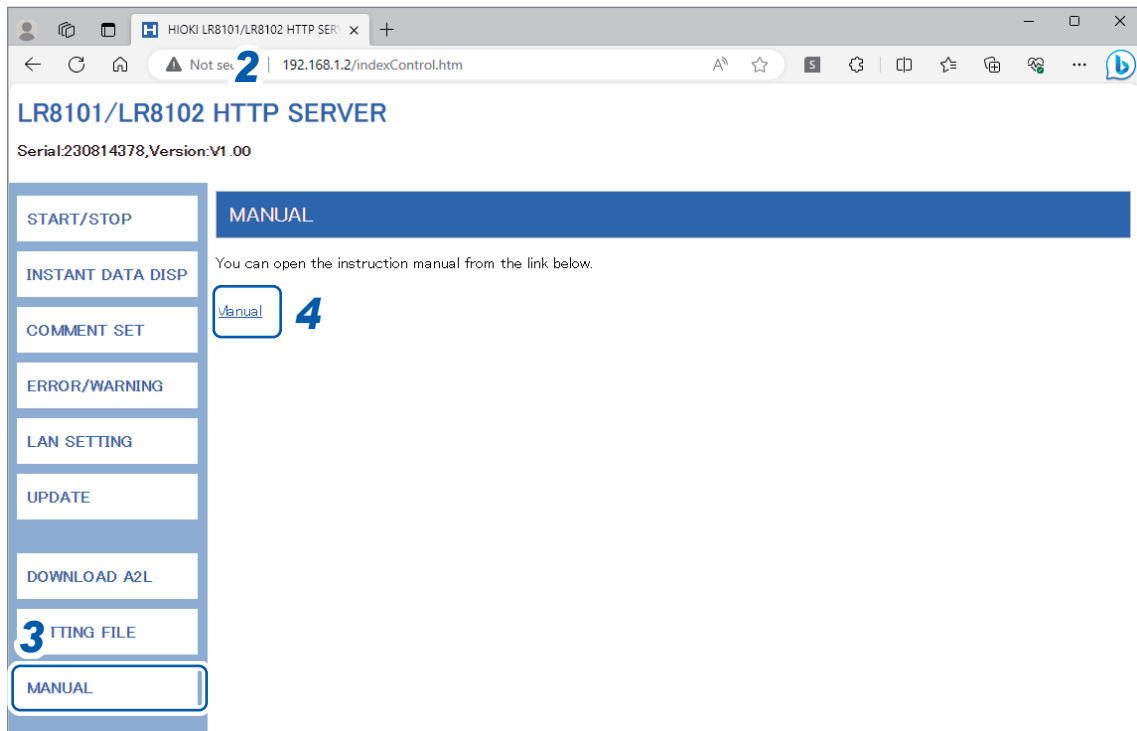

- 1** Open a browser on the PC.
- 2** Enter the instrument's address in the address bar. (Example: **http://192.168.1.2**)
- 3** Click **[MANUAL]**.  
Download the Instruction Manual for the instrument.
- 4** Click **[Manual]**.  
The Instruction Manual in PDF format is displayed.

## 12.3 Acquiring Data with the FTP Server

With the FTP server function, files stored on the instrument can be acquired on a PC. The File Transfer Protocol (FTP) is a protocol to transfer files within a network. By running an FTP client on a PC, files stored on the SD memory card or USB drive can be acquired on the PC.

- 1 Enter the instrument's address in the address bar of the explorer. (Example: ftp://192.168.1.2)**

The "sdcard" and "usb" folders are displayed.

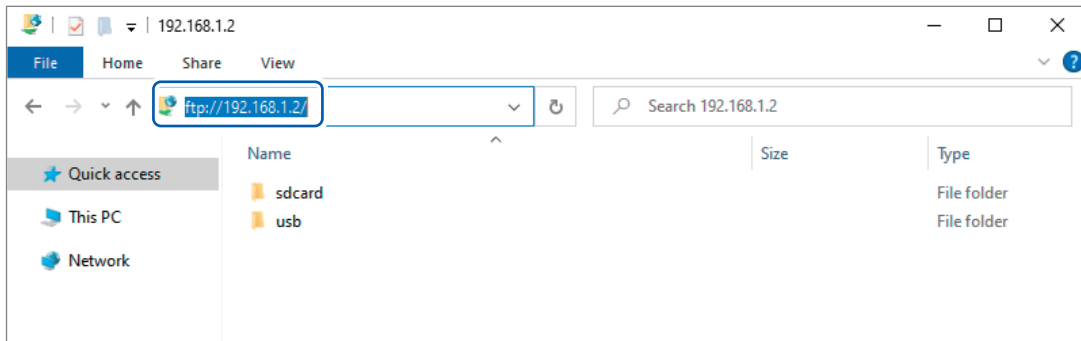

- 2 Double-click the item to acquire data.**

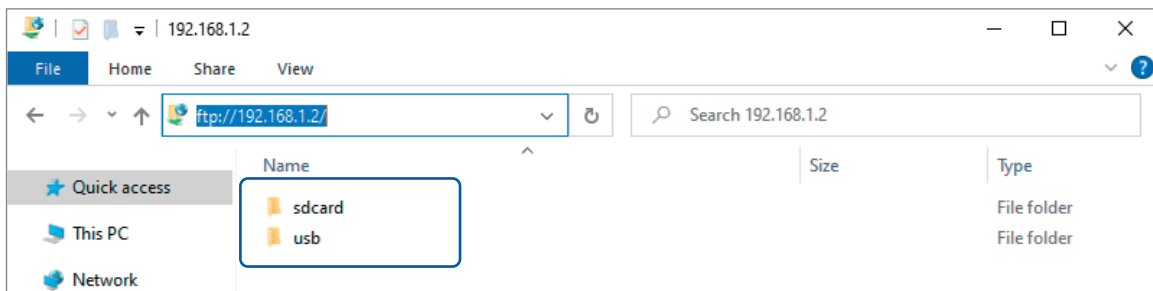

|               |                |
|---------------|----------------|
| <b>sdcard</b> | SD memory card |
| <b>usb</b>    | USB drive      |

Opens the folder.

- 3 Right-click the file name and click [Copy To Folder].**

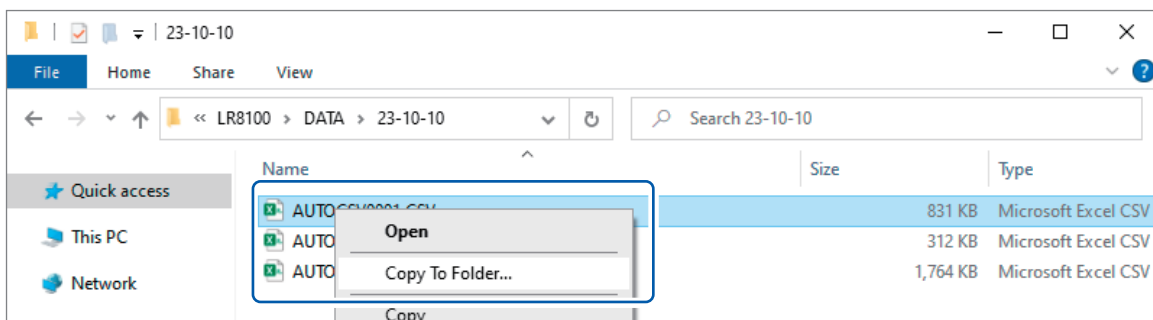

Executes the file copy.

**IMPORTANT**

Some PC's FTP client software delete selected files and folders being moved if the move operation is canceled. Exercise caution when moving files and folders. Instead of moving the data, it is recommend to copy and acquire the data and then delete the data.

- The instrument's FTP server supports only one connection. It is not possible to access it simultaneously from multiple PCs.
- The FTP connection may be disconnected if 1 minute or more passes without a command being sent after the connection is initiated. In this case, connect to the FTP server again.
- Reconnection to the FTP server may not be possible immediately after the FTP connection is disconnected. In this case, wait for approx. 1 minute and then connect to the FTP server again.
- Disconnect the FTP connection before exchanging the SD memory cards or USB drives.
- Do not use the communication commands related to the file operations and FTP simultaneously. Doing so may result in an unexpected operation.
- Free software, such as FFFTP, is also available.
- If the file operation or transfer is executed during the auto-save operation, the saving speed of the auto-save operation is slowed down.

## 12.4 Sending Data Using the FTP Client

Any files automatically saved in the media (SD memory card and USB drive) of the instrument can be automatically sent to the FTP server on the PC.

Specify the IP address of the PC with the FTP server operating.

It is necessary to register the user name and password of the instrument in the FTP server. For details, see HELP of Windows FTP server.

A Windows FTP server, etc. may be used.

In addition to a Windows FTP server, free software FILEZILLA (Third-party company's trademark) Server, etc. may be used.

- Set **A\$** under **:CONFigure:ATSAve** to anything other than OFF.
- To send data periodically, set **A\$** under **:CONFigure:SAVEKind** to anything other than **NORMal**.
- To send data continuously even when the SD card or USB drive runs low on free space, perform settings so that auto saving can be continued by deleting the oldest waveform file (binary or text) under **:CONFigure:SAVEMode REMOVE**.

See "Auto save (Realtime save)" (p. 164).

- 1** Set and connect the LAN. (p.260)
- 2** Set the FTP server on the PC. (p.265)
- 3** Run FTP auto send on the instrument. (p.270)
- 4** Configure the auto-save settings on the instrument. (p.164)
- 5** Start measurement on the instrument.

When the auto-save operation is executed on the instrument, the files are automatically sent to the FTP server on the PC.

- 6** Check the communication status. (p.276)



## Enable FTP (for Windows 10)

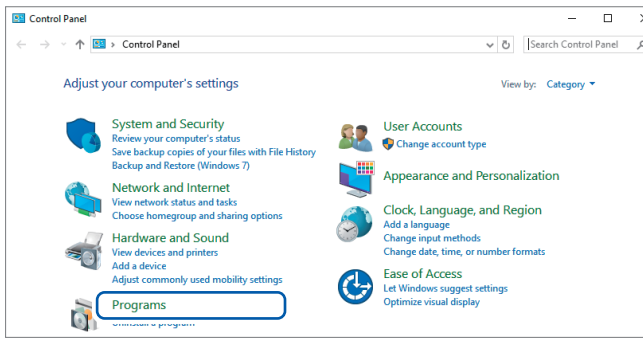

**1** Click **[Control Panel]** > **[Program]**.

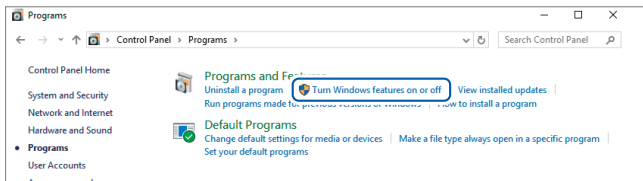

**2** Click **[Turn Windows features on or off]**.

The **[Windows Features]** dialog box is displayed.

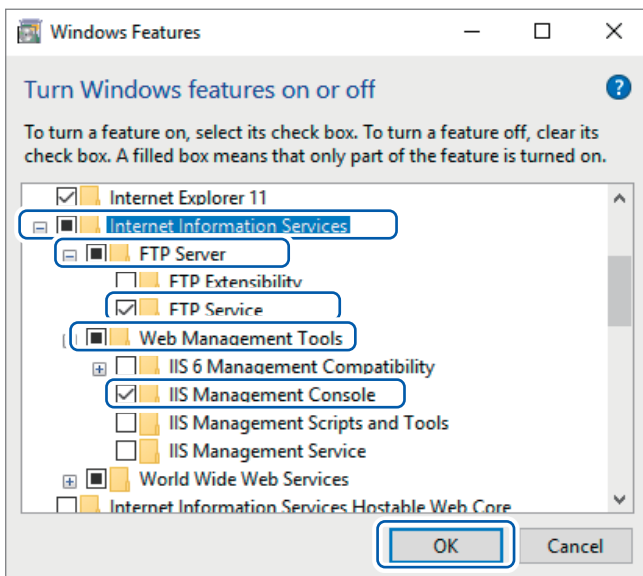

**3** Click **[+]** on the left of **[Internet Information Services]** to expand it.

Click **[+]** on the left of **[FTP server]** to expand it. Select **[FTP Service]**.

Click **[+]** on the left of **[Web Management Tools]** to expand it. Select **[IIS Management Console]**.

Click **[OK]**.

This completes the installation of FTP.

When the installation is completed, the **[inetpub]** folder is created in the root of drive C.

## Set FTP (for Windows 10)

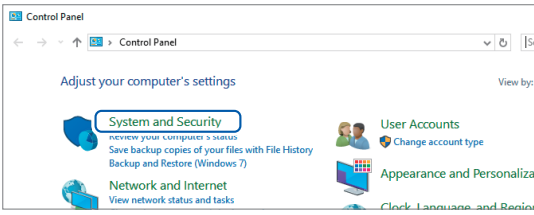

1 Click **[Control Panel]** > **[System and Security]**.

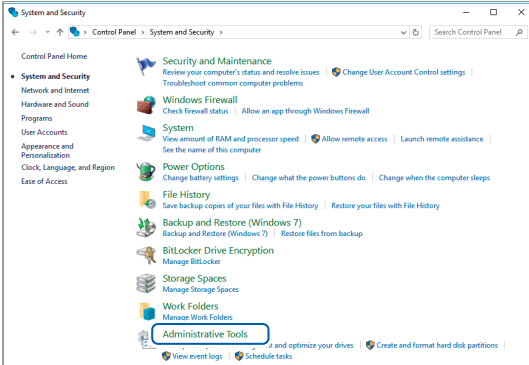

2 Click **[Administrative Tools]**.

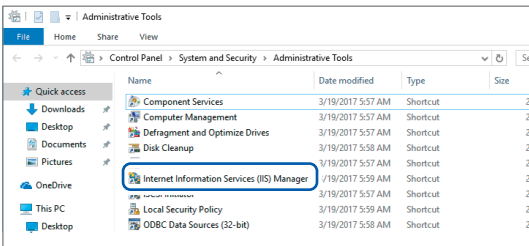

3 Double-click **[Internet Information Services (IIS) Manager]**.

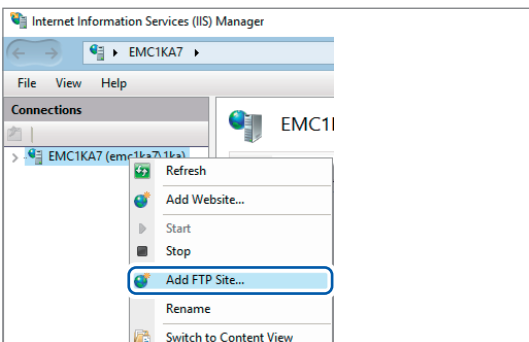

4 Right-click the item displayed in the **[Connections]** field on the left of the screen. Click **[Add FTP Site...]** in the shortcut menu.

Communication may be blocked based on the settings of your PC's security software, such as a firewall.

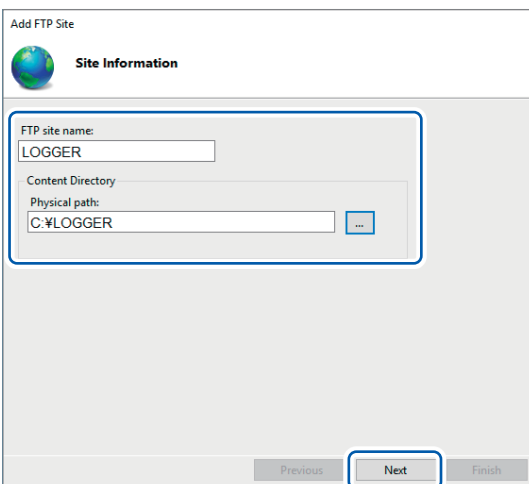

5 Enter **[Site Information]**.

Example:

**[FTP site name]:** **LOGGER**

Specify a location to save the data from the FTP client in **[Physical path]** of **[Content Directory]**.

Click **[Next]**.

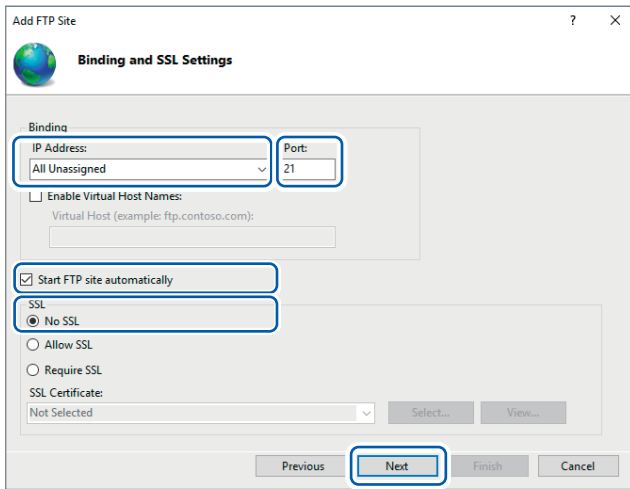

**6** Set **[Binding]** and **[SSL]** as follows.

|                                       |                         |
|---------------------------------------|-------------------------|
| <b>[IP address]</b>                   | <b>[All Unassigned]</b> |
| <b>[Port]</b>                         | <b>[21]</b>             |
| <b>[Start FTP site automatically]</b> | Select                  |
| <b>[SSL]</b>                          | <b>[No SSL]</b>         |

Click **[Next]**.

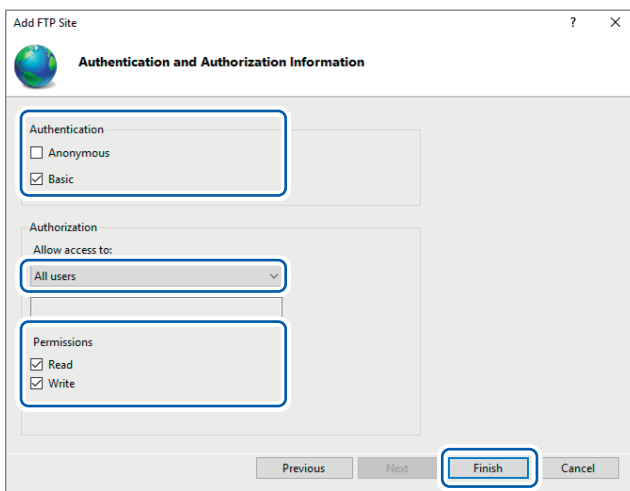

**7** Set **[Authentication and Authorization Information]** as follows.

|                         |  |
|-------------------------|--|
| <b>[Authentication]</b> | Select <b>[Basic]</b>                        |
| <b>[Authorization]</b>  | <b>[All users]</b>                           |
| <b>[Permissions]</b>    | Select both <b>[Read]</b> and <b>[Write]</b> |

Click **[Finish]**.

### Set users accessing FTP (for Windows 10)

Enter the username and password to access the FTP.

Enter [User name] and [Password] specified here in the [User name] and [Password] boxes on the FTP auto send setting screen on the instrument.

See “2 Set each item” (page 273).

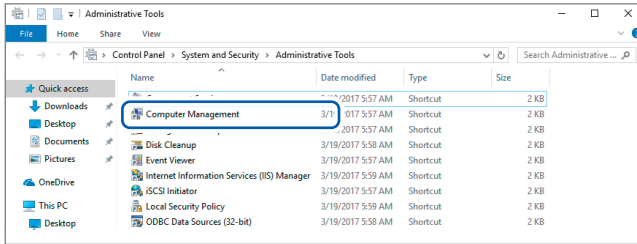

**1** From [Administrative Tools] in step 2 (p.266), select [Computer Management].

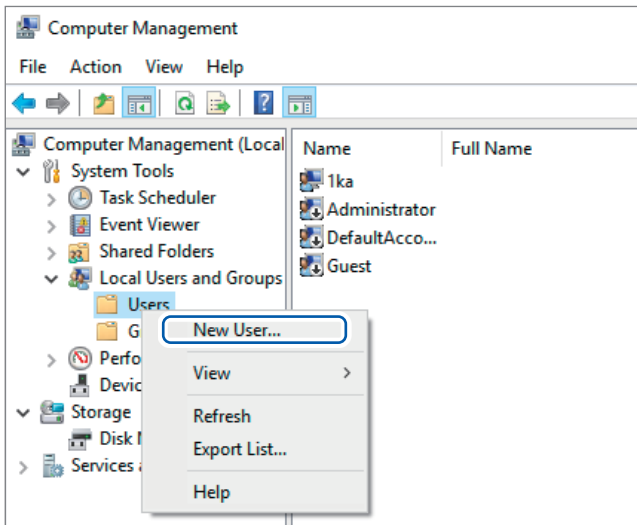

**2** Right-click [Users] in [Local Users and Groups]. Select [New User] in the shortcut menu.

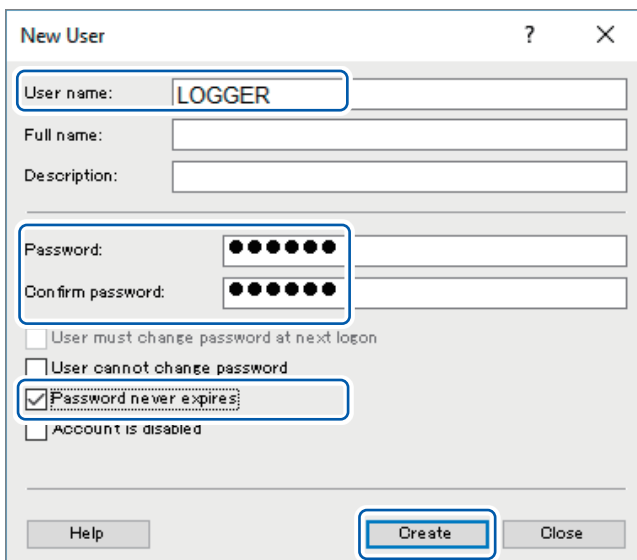

**3** Enter the user name in the [User name] box and the password in the [Password] and [Confirm password] boxes. Select the [Password never expires] check box.

Click [Create].

## Set the firewall (for Windows 10)

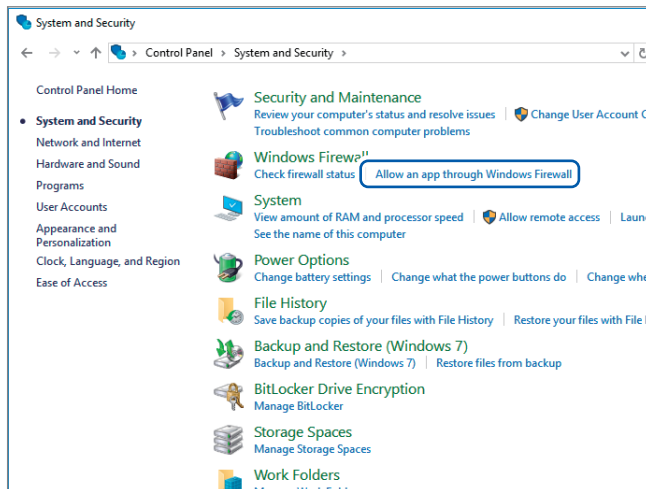

**4** From [System and Security] in step 1 (“1 Click [Control Panel] > [System and Security].” (p. 266), click [Allow an app through Windows Firewall].

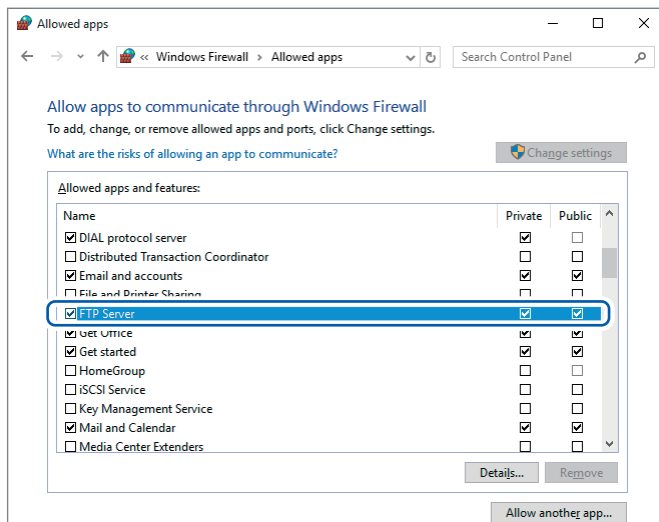

**5** Select [FTP server].  
Select Private or Public, whichever is connected with the instrument.

## Restart the FTP server

Restart Microsoft FTP Service in [Control Panel] > [System and Security] > [Administrative Tools] > [Services].

This completes the FTP settings for Windows 10.



There is a possibility that the connection with the Logger may be blocked by security software or other types of software. Confirm that the connection with the target Logger is not blocked by software.

## Setting auto send

Any files automatically saved in the media of the instrument can be sent to the FTP server on the PC automatically.

### Operation method

The following shows an example of sending data to FTP server 192.168.1.1.

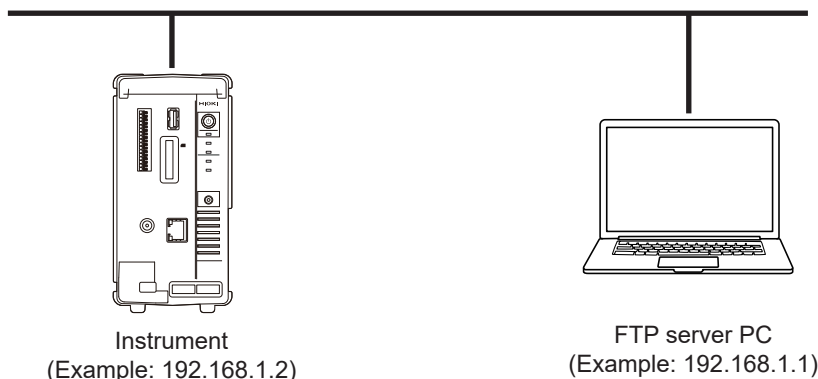

#### 1 Set the FTP data auto send function.

| Settings                      |                                  |   |
|-------------------------------|----------------------------------|---|
| Syntax                        | Command                          | <code>:SYSTem:FTP:USE A\$</code>  |
| Example                       |                                  | <code>:SYSTem:FTP:USE ON</code>   |
| Query                         |                                  |   |
| Syntax                        | Query                            | <code>:SYSTem:FTP:USE?</code>   |
|                               | Response                         | <code>A\$</code>  |
| Example                       |                                  | <code>:SYSTem:FTP:USE?</code><br>(Response) <code>:SYSTEM:FTP:USE ON</code> (When the header is ON) |
| Parameter                     |                                  |   |
| <code>A\$</code> = OFF, ON    |                                  |   |
| <code>OFF</code> <sup>□</sup> | Disables the FTP data auto send. |   |
| <code>ON</code>               | Enables the FTP data auto send.  |   |

#### 2 Set the FTP server name.

Sets the host name or IP address of the FTP server.

See "Network settings on PC" (p. 63).

| Settings  |          |  |
|---|----------|--|
| Syntax  | Command  | <code>:SYSTem:FTP:ADDRESS "A\$"</code>   |
| Example   |          | <code>:SYSTem:FTP:ADDRESS "HIOKI_FTP"</code>   |
| Query   |          |  |
| Syntax  | Query    | <code>:SYSTem:FTP:ADDRESS?</code>  |
|   | Response | <code>"A\$"</code>   |
| Example   |          | <code>:SYSTem:FTP:ADDRESS?</code><br>(Response) <code>:SYSTEM:FTP:ADDRESS "HIOKI_FTP"</code> (When the header is ON) |
| Parameter   |          |  |
| <code>A\$</code> = Destination FTP server address (up to 45 single-byte characters) |          |  |

### 3 Set the connection security.

Configure the settings according to the security method supported by the FTP server.

| Settings                                   |   |                                       |
|--|---|---------------------------------------|
| Syntax                                     | Command   | <code>:SYSTem:FTP:SECURity A\$</code> |
| Example                                    | <code>:SYSTem:FTP:SECURity EXPLICIT</code>  |                                       |
| Query                                      |   |                                       |
| Syntax                                     | Query   | <code>:SYSTem:FTP:SECURity?</code>    |
|  | Response  | <code>A\$</code>                      |
| Example                                    | <code>:SYSTem:FTP:SECURity?</code><br>(Response) <code>:SYSTEM:FTP:SECURITY EXPLICIT</code> (When the header is ON) |                                       |
| Parameter                                  |   |                                       |
| <code>A\$</code> = OFF, EXPLICIT, IMPLICIT |   |                                       |
| <code>OFF</code> <sup>□</sup>              | Communications are not secure.  |                                       |
| <code>EXPLICIT</code>                      | Explicit FTP over TLS   |                                       |
| <code>IMPLICIT</code>                      | Implicit FTP over TLS   |                                       |

### 4 Set the server certificate confirmation.

| Settings                     |  |  |
|------------------------------|--|--|
| Syntax                       | Command  | <code>:SYSTem:FTP:CERTIFICATE A\$</code> |
| Example                      | <code>:SYSTem:FTP:CERTIFICATE ON</code>  |  |
| Query                        |  |  |
| Syntax                       | Query  | <code>:SYSTem:FTP:CERTIFICATE?</code>    |
|                              | Response   | <code>A\$</code>                         |
| Example                      | <code>:SYSTem:FTP:CERTIFICATE?</code><br>(Response) <code>:SYSTEM:FTP:CERTIFICATE ON</code> (When the header is ON)    |  |
| Parameter                    |  |  |
| <code>A\$</code> = OFF, ON   |  |  |
| <code>OFF</code>             | Files are transferred via encrypted communications. However, the certificate presented by the server is not validated. |  |
| <code>ON</code> <sup>□</sup> | The certificate presented by the server is validated. If the validity is not confirmed, no file is transferred.        |  |

### 5 Set the port number of the FTP server.

| Settings   |   |   |
|--|---|---|
| Syntax   | Command   | <code>:SYSTem:FTP:PORT A</code>   |
|  |   | (When the connection security is set to IMPLICIT)<br><code>:SYSTem:FTP:PORT:IMPLIcit A</code> |
| Example  | <code>:SYSTem:FTP:PORT 1234</code>  |   |
| Query  |   |   |
| Syntax   | Query   | <code>:SYSTem:FTP:PORT?</code>  |
|  | Response  | <code>A\$</code>  |
| Example  | <code>:SYSTem:FTP:PORT?</code><br>(Response) <code>:SYSTEM:FTP:PORT 1234</code> (When the header is ON) |   |
| Parameter  |   |   |
| <code>A\$</code> = 1 to 21 <sup>□</sup> to 65535<br>When the connection security is set to <code>IMPLICIT</code> , the default setting is 990. |   |   |

## 6 Set the user name.

Sets the user name for logging on to the FTP server.

Set the username for the instrument registered with the FTP server on the PC.

| Settings  |   |                          |
|---|---|--------------------------|
| Syntax  | Command   | :SYSTem:FTP:USER "A\$" " |
| Example   | :SYSTem:FTP:USER "LOGGER"   |                          |
| Query   |   |                          |
| Syntax  | Query   | :SYSTem:FTP:USER?        |
|   | Response  | "A\$"                    |
| Example   | :SYSTem:FTP:USER?<br>(Response) :SYSTEM:FTP:USER "LOGGER" (When the header is ON) |                          |
| Parameter   |   |                          |
| A\$ = User name (up to 32 single-byte characters) |   |                          |

## 7 Set the password.

Sets the password for logging on to the FTP server.

Set the password for the instrument registered with the FTP server on the PC.

For the query, the entered password is checked against the current password setting and the result is returned.

| Settings   |  |                             |
|--|--|-----------------------------|
| Syntax   | Command  | :SYSTem:FTP:PASSword "A\$"  |
| Example  | :SYSTem:FTP:PASSword "abcd"  |                             |
| Query  |  |                             |
| Syntax   | Query  | :SYSTem:FTP:PASSword? "A\$" |
|  | Response   | B\$                         |
| Example  | :SYSTem:FTP:PASSword? "abcd"<br>(Response) :SYSTEM:FTP:PASSWORD PASS (When the header is ON) |                             |
| Parameter  |  |                             |
| A\$ = Password (up to 32 single-byte characters) |  |                             |
| B\$ = PASS, FAIL                                 |  |                             |
| PASS   | The entered password is correct.   |                             |
| FAIL   | The entered password is incorrect.   |                             |

## 8 Set the saving destination directory.

Specifies the director on the FTP server for saving data. (Default: Serial number of the instrument)

| Settings  |  |                       |
|---|--|-----------------------|
| Syntax  | Command  | :SYSTem:FTP:DIR "A\$" |
| Example   | :SYSTem:FTP:DIR "/abc/def/"  |                       |
| Query   |  |                       |
| Syntax  | Query  | :SYSTem:FTP:DIR?      |
|   | Response   | "A\$"                 |
| Example   | :SYSTem:FTP:DIR?<br>(Response) :SYSTEM:FTP:DIR "/abc/def/" (When the header is ON) |                       |
| Parameter   |  |                       |
| A\$ = Destination directory (up to 45 single-byte characters) |  |                       |



**9** Set the PASV mode.

| Settings                     |  |                              |
|------------------------------|--|------------------------------|
| Syntax                       | Command  | :SYSTem:FTP:PA <b>SV</b> A\$ |
| Example                      | :SYSTem:FTP:PA <b>SV</b> ON  |                              |
| Query                        |  |                              |
| Syntax                       | Query  | :SYSTem:FTP:PA <b>SV</b> ?   |
|                              | Response   | A\$                          |
| Example                      | :SYSTem:FTP:PA <b>SV</b> ?<br>(Response) :SYSTEM:FTP:PA <b>SV</b> ON (When the header is ON) |                              |
| Parameter                    |  |                              |
| A\$ = OFF, ON                |  |                              |
| OFF <input type="checkbox"/> | Does not use the PASV mode during communication.   |                              |
| ON                           | Uses the PASV mode during communication.   |                              |

**10** Specify the deletion of sent files.

| Settings                     |  |                                 |
|------------------------------|--|---------------------------------|
| Syntax                       | Command  | :SYSTem:FTP:AUTODe <b>l</b> A\$ |
| Example                      | :SYSTem:FTP:AUTODe <b>l</b> ON   |                                 |
| Query                        |  |                                 |
| Syntax                       | Query  | :SYSTem:FTP:AUTODe <b>l</b> ?   |
|                              | Response   | A\$                             |
| Example                      | :SYSTem:FTP:AUTODe <b>l</b> ?<br>(Response) :SYSTEM:FTP:AUTODe <b>l</b> ON (When the header is ON) |                                 |
| Parameter                    |  |                                 |
| A\$ = OFF, ON                |  |                                 |
| OFF <input type="checkbox"/> | Does not delete sent files.  |                                 |
| ON                           | Deletes sent files.  |                                 |

## 11 Set the file name identifier.

| Settings        |   |   |
|-----------------|---|---|
| Syntax          | Command   | :SYSTem:FTP:FILE:HOST A\$ (Host name)<br>:SYSTem:FTP:FILE:IP A\$ (IP address)<br>:SYSTem:FTP:FILE:TIME A\$ (Time) |
| Example         | :SYSTem:FTP:FILE:HOST ON  |   |
| Query           |   |   |
| Syntax          | Query   | :SYSTem:FTP:FILE:HOST? (Host name)<br>:SYSTem:FTP:FILE:IP? (IP address)<br>:SYSTem:FTP:FILE:TIME? (Time)          |
|                 | Response  | A\$   |
| Example         | :SYSTem:FTP:FILE:HOST?<br>(Response) :SYSTEM:FTP:FILE:HOST ON (When the header is ON) |   |
| Parameter       |   |   |
| A\$ = OFF, ON   |   |   |
| OFF             | Does not attach the target to file names.   |   |
| ON <sup>☑</sup> | Attaches the target to file names.  |   |

Example:

|                     |                    |
|---------------------|--------------------|
| Host name           | LOGGER             |
| IP address          | 192.168.1.2        |
| Time                | '23-01-10 08:30:05 |
| Auto-save file name | AUTO0001.MEM       |

With the settings above, the file is named as follows when the file name identifier is set to ON for the host name, IP address, and time.

**[LOGGER\_192-168-1-2\_230110-083005\_AUTO0001.MEM]**

Files can be identified when multiple loggers are used.

## 12 Perform the upload test.

See "File upload test" (p. 275).

## File upload test

Check whether files can be sent using the FTP client.

### 1 Execute the upload test.

| Query                     |  |                    |
|---------------------------|--|--------------------|
| Syntax                    | Query  | :SYSTem:FTP:CHECK? |
|                           | Response   | A                  |
| Example                   | :SYSTem:FTP:CHECK?<br>(Response) :SYSTEM:FTP:CHECK 0 (When the header is ON) |                    |
| Parameter                 |  |                    |
| A = 0 (Success), 1 (Fail) |  |                    |

Test file [FTP\_TEST.TXT] is sent to the specified folder\*1.

\*1: The folder specified with [Physical path] in “Enter [Site Information].” (p. 266) and “Set the saving destination directory.” (p. 272) (example: C:\LOGGER\data)

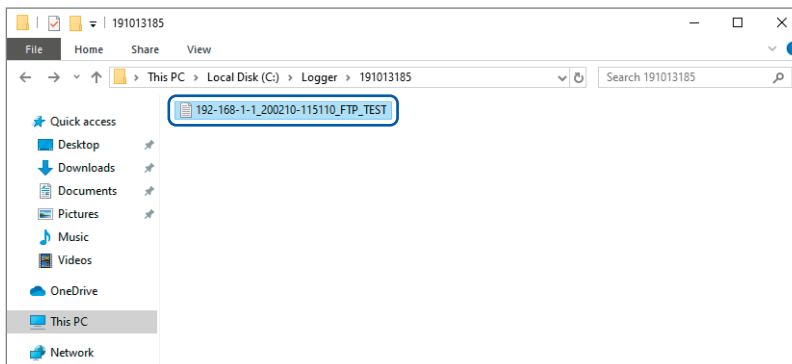

When the test file cannot be sent, check the auto send settings of the instrument and the FTP settings of the PC.

If the send test is successful, start measurement.

The measured waveform data are automatically sent to the FTP server on the PC.

### Data send time

Transfer time (sec.) = File size (KB)/Transfer speed (KB/sec.) + Transfer preparation time (sec.)

For details about the file size, see “14.7 File Size” (p. 328).

For reference, the transfer speed is 4 MB/sec. and the transfer preparation time is 3 seconds.

Example: If the file size is 40 MB

$$\text{Transfer time} = 40 \text{ MB} / 4 \text{ (MB/sec)} + 3 \text{ (sec)}$$

$$= 10 + 3 \text{ (sec)} = 13 \text{ (sec)}$$

## FTP communication status check

You can check the numbers of files that have been sent successfully, have failed to be sent, etc. using the FTP client.

### 1 Check the numbers of files under the FTP communication status.

| Query   |   |   |
|---|---|---|
| Syntax  | Query   | <code>:SYSTem:FTP:STATe?</code>                                     |
|   | Response  | <code>A&lt;NR1&gt;, B&lt;NR1&gt;, C&lt;NR1&gt;, D&lt;NR1&gt;</code> |
| Example   | <code>:SYSTem:FTP:STATe?</code><br>(Response) <code>:SYSTEM:FTP:STATE 10,1,5,4</code> (When the header is ON) |   |
| Parameter   |   |   |
| <b>A</b> = Total number of files<br><b>B</b> = Numbers of files that have been sent successfully<br><b>C</b> = Numbers of files that have failed to be sent<br><b>D</b> = Number of files that have not been sent |   |   |

### 2 Check whether or not there is a file under the FTP communication status that has not been sent.

| Query                |  |                                    |
|----------------------|--|------------------------------------|
| Syntax               | Query  | <code>:SYSTem:FTP:PROGress?</code> |
|                      | Response   | <code>A\$</code>                   |
| Example              | <code>:SYSTem:FTP:PROGress?</code><br>(Response) <code>:SYSTEM:FTP:PROGRESS YES</code> (When the header is ON) |                                    |
| Parameter            |  |                                    |
| <b>A\$</b> = YES, NO |  |                                    |
| <b>YES</b>           | There is a file that has not been sent.  |                                    |
| <b>NO</b>            | There are no unsent files.   |                                    |

## 12.5 Sending Measurement Data Using XCP on Ethernet

The instrument supports only the measurement mode of XCP on Ethernet and can be connected with higher level tools complying with the ASAM standards.

The LAN setting and connection are required to send the measurement data using XCP on Ethernet.

For the XCP connection, use LR8101 or LR8102 to create the setting file (A2L) specific to the instrument.

If the instrument settings have been changed after creating the A2L file, recreate the A2L file and use the latest A2L file.

The instrument does not support asynchronous upload of the measurement data with polling from ECU measurement/compatible software.

The XCP output of LAN2 can be performed at the recording intervals in real time.

The XCP output from LAN1 does not support the output in real time. The timing for LAN1 to send the measurement data to ECU measurement/compatible software is only when the command is sent from the software to the instrument.

### Setting the input channel

---

See “3.4 Setting the Voltage/Temp Module” (p. 94).

## Creating the A2L file

### 1 Specify the file name when saving.

| Settings   |   |                        |
|--|---|------------------------|
| Syntax   | Command   | :SYSTem:FILEName "A\$" |
| Example  | :SYSTem:FILEName "MANUAL"                                 |                        |
| Query  |   |                        |
| Syntax   | Query   | :SYSTem:FILEName?      |
|  | Response  | "A\$"                  |
| Example  | :SYSTem:FILEName?<br>(Response) :SYSTEM:FILENAME "MANUAL" |                        |
| Parameter  |   |                        |
| A\$ = Character string of file name (up to 4 double-byte characters or 8 single-byte characters) |   |                        |

If no file name is specified, the file is named automatically.  
See "When a file is saved without specifying a file name" (p. 160).

### 2 Save the A2L file.

When the file is saved using LAN1: Communication takes place via the LAN1 port. The communication protocol is TCP.

When the file is saved using LAN2: Communication takes place using the LAN2 port. The communication protocol is UDP.

The A2L file contains only the information of channels in which the measurement are set to ON on the instrument.

| Settings   |   |  |
|--|---|--|
| Syntax   | Command   | When LAN1 is used<br>:MEDia:SD:SAVE:A2L:LAN1<br>:MEDia:USB:SAVE:A2L:LAN1<br>When LAN2 is used<br>:MEDia:SD:SAVE:A2L:LAN2<br>:MEDia:USB:SAVE:A2L:LAN2     |
| Example  | :MEDia:SD:SAVE:A2L:LAN1   |  |
| Query  |   |  |
| Syntax   | Query   | When LAN1 is used<br>:MEDia:SD:SAVE:A2L:LAN1?<br>:MEDia:USB:SAVE:A2L:LAN1?<br>When LAN2 is used<br>:MEDia:SD:SAVE:A2L:LAN2?<br>:MEDia:USB:SAVE:A2L:LAN2? |
|  | Response  | A\$  |
| Example  | :MEDIA:SD:SAVE:A2L:LAN1?<br>(Response) :MEDIA:SD:SAVE:A2L:LAN1? SUCCESS_TEST<br>(When the header is ON) |  |
| Parameter  |   |  |
| A\$ = NONE, EXECUTING, SUCCESS_(File name), FAIL |   |  |
| NONE   | Saving has not yet been executed.   |  |
| EXECUTING  | Saving is currently in operation.   |  |
| SUCCESS  | Saving has succeeded. The name of the saved file is attached at the end.                                |  |
| FAIL   | Saving has failed.  |  |

## Settings on ECU control software

---

### Setting the measurement channels

Before measurement, initialize and create the DAQ list using ECU control software and set the information of measurement channels on the ODT entry.

The DAQ list cannot be initialized or created while the instrument is performing the measurement.

## 12.6 Outputting the Measured Value Using CAN

Output the measured value of the instrument to the CAN bus.  
 The CAN-H and CAN-L terminals are used for the CAN measured value output.  
 For the method of connecting the CAN cable, see “Wiring the CAN cable (LR8102 only)” (p. 51).  
 For the setting method, see “CAN Editor Instruction Manual”.

### 1 Set the measured value output function.

You can choose whether to output the measurement data using the settings configured in the CAN Editor.

| Settings                |   |                   |
|-------------------------|---|-------------------|
| Syntax                  | Command   | :SYSTem:RTOut A\$ |
| Example                 | :SYSTem:RTOut CAN   |                   |
| Query                   |   |                   |
| Syntax                  | Query   | :SYSTem:RTOut?    |
|                         | Response  | A\$               |
| Example                 | :SYSTem:RTOut?<br>(Response) :SYSTEM:RTOUT CAN (When the header is ON)                                |                   |
| Parameter               |   |                   |
| A\$ = OFF, CAN, LAN2udp |   |                   |
| OFF <sup>☑</sup>        | Does not output the data from CAN or LAN2.  |                   |
| CAN                     | Outputs the data from the CAN terminal.<br>When an external sampling is used, the time is not output. |                   |
| LAN2udp                 | Outputs the data from LAN2.   |                   |

If the instrument is controlled with XCP on Ethernet UDP, the data are not output regardless of the settings.

The parameter can also be set to CAN when setting the instrument from CAN Editor.



## 12.7 Setting and Connecting LAN2

The instrument and a PC can be connected using a LAN cable.

Connect the LAN cable to the LAN2 port. The measured value can be output in real time.

The default IP address of the instrument is 192.168.1.102. The port number is 8801 and the output destination port number is 8800.

Send the following communication commands from the PC to LAN1 (communication command port: 8802).

LAN2 does not support the communication commands. Set LAN2 from LAN1.

### Updates the settings of LAN2.

#### IMPORTANT

The LAN2 settings will not be updated until this command is executed.  
Execute the command after completing the LAN2 settings.

| Settings |         |                                 |
|----------|---------|---------------------------------|
| Syntax   | Command | :SYSTem:COMMunicate:LAN2:UPDate |
| Example  |         | :SYSTem:COMMunicate:LAN2:UPDate |

### DHCP server

When the DHCP server is set to ON, the IP address and the subnet mask can be obtained automatically. For [PREParation?](#), the setting made before the update of the LAN2 settings is returned.

| Settings         |                             |   |
|------------------|-----------------------------|---|
| Syntax           | Command                     | :SYSTem:COMMunicate:LAN2:DHCP A\$   |
| Example          |                             | :SYSTem:COMMunicate:LAN2:DHCP ON<br>:SYSTem:COMMunicate:LAN2:UPDate                                   |
| Query            |                             |   |
| Syntax           | Query                       | :SYSTem:COMMunicate:LAN2:DHCP?<br>:SYSTem:COMMunicate:LAN2:DHCP:PREParation?                          |
|                  | Response                    | A\$   |
| Example          |                             | :SYSTem:COMMunicate:LAN2:DHCP?<br>(Response) :SYSTEM:COMMUNICATE:LAN2:DHCP ON (When the header is ON) |
| Parameter        |                             |   |
| A\$ = OFF,ON     |                             |   |
| OFF <sup>□</sup> | Disables the DHCP function. |   |
| ON               | Enables the DHCP function.  |   |

### Host name

For **PREPAratiOn?**, the setting made before the update of the LAN2 settings is returned.

| Settings  |          |   |
|---|----------|---|
| Syntax  | Command  | :SYSTem:COMMunicate:LAN2:HOSTname "A\$"   |
| Example   |          | :SYSTem:COMMunicate:LAN2:HOSTname "LOGGER"<br>:SYSTem:COMMunicate:LAN2:UPDate                                       |
| Query   |          |   |
| Syntax  | Query    | :SYSTem:COMMunicate:LAN2:HOSTname?<br>:SYSTem:COMMunicate:LAN2:HOSTname:PREPAratiOn?                                |
|   | Response | "A\$"   |
| Example   |          | :SYSTem:COMMunicate:LAN2:HOSTname?<br>(Response) :SYSTEM:COMMUNICATE:LAN2:HOSTNAME "LOGGER" (When the header is ON) |
| Parameter   |          |   |
| A\$ = Character string of host name (up to 12 single-byte characters) |          |   |

### Set the IP address of the instrument.

The IP address is used to identify individual devices that are connected to the network. Ensure that the instrument uses a unique name that is not being used by any other device on the network.

For **PREPAratiOn?**, the setting made before the update of the LAN2 settings is returned.

| Settings  |          |   |
|-----------|----------|---|
| Syntax    | Command  | :SYSTem:COMMunicate:LAN2:IPADdress ip1,ip2,ip3,ip4  |
| Example   |          | :SYSTem:COMMunicate:LAN2:IPADdress 192,168,1,200<br>:SYSTem:COMMunicate:LAN2:UPDate   |
| Query     |          |   |
| Syntax    | Query    | :SYSTem:COMMunicate:LAN2:IPADdress?<br>:SYSTem:COMMunicate:LAN2:IPADdress:PREPAratiOn?  |
|           | Response | ip1<NR1>, ip2<NR1>, ip3<NR1>, ip4<NR1>  |
| Example   |          | :SYSTem:COMMunicate:LAN2:IPADdress?<br>(Response) :SYSTEM:COMMUNICATE:LAN2:IPADDRESS 192,168,1,200<br>(When the header is ON) |
| Parameter |          |   |
| ip1       | 0 to 255 |   |
| ip2       | 0 to 255 |   |
| ip3       | 0 to 255 |   |
| ip4       | 0 to 255 |   |

**Set the subnet mask of LAN2.**

The subnet mask is used to separate the IP address into the portion that indicates the network and the portion that indicates the device.

Ensure that the instrument uses the same subnet mask that is being used by other devices on the same network.

For **PREParation?**, the setting made before the update of the LAN2 settings is returned.

| Settings           |          |   |
|--------------------|----------|---|
| <b>Syntax</b>      | Command  | <code>:SYSTem:COMMunicate:LAN2:SMASk mask1,mask2,mask3,mask4</code>   |
| <b>Example</b>     |          | <code>:SYSTem:COMMunicate:LAN2:SMASk 255,255,255,0</code><br><code>:SYSTem:COMMunicate:LAN2:UPDate</code>                                       |
| Query              |          |   |
| <b>Syntax</b>      | Query    | <code>:SYSTem:COMMunicate:LAN2:SMASk?</code><br><code>:SYSTem:COMMunicate:LAN2:SMASk:PREParation?</code>  |
|                    | Response | <code>mask1&lt;NR1&gt;,mask2&lt;NR1&gt;,mask3&lt;NR1&gt;,mask4&lt;NR1&gt;</code>  |
| <b>Example</b>     |          | <code>:SYSTem:COMMunicate:LAN2:SMASk?</code><br>(Response) <code>:SYSTEM:COMMUNICATE:LAN2:SMASK 255,255,255,0</code><br>(When the header is ON) |
| Parameter          |          |   |
| <code>mask1</code> | 0 to 255 |   |
| <code>mask2</code> | 0 to 255 |   |
| <code>mask3</code> | 0 to 255 |   |
| <code>mask4</code> | 0 to 255 |   |

**Set the port number of the instrument.**

The last digit is used by the LAN2 system.

Example: No matter which number between 8800 and 8809 is specified, the parameter is set to 8800. 8801 is used for the UDP output.

(The last digit: 1 for the UDP output, 5 for XCP on Ethernet)

For **PREParation?**, the setting made before the update of the LAN2 settings is returned.

| Settings        |                 |  |
|-----------------|-----------------|--|
| <b>Syntax</b>   | Command         | <code>:SYSTem:COMMunicate:LAN2:CONTrol no</code>   |
| <b>Example</b>  |                 | <code>:SYSTem:COMMunicate:LAN2:CONTrol 8800</code><br><code>:SYSTem:COMMunicate:LAN2:UPDate</code>   |
| Query           |                 |  |
| <b>Syntax</b>   | Query           | <code>:SYSTem:COMMunicate:LAN2:CONTrol?</code><br><code>:SYSTem:COMMunicate:LAN2:CONTrol:PREParation?</code>                               |
|                 | Response        | <code>no&lt;NR1&gt;</code>   |
| <b>Example</b>  |                 | <code>:SYSTem:COMMunicate:LAN2:CONTrol?</code><br>(Response) <code>:SYSTEM:COMMUNICATE:LAN2:CONTROL 8800</code><br>(When the header is ON) |
| Parameter       |                 |  |
| <code>no</code> | = 1020 to 65520 |  |

### Gateway IP

Setting 0.0.0.0 disables the use of the Gateway.

If the DHCP server is set to **ON**, the setting will be configured automatically.

For **PREPARation?**, the setting made before the update of the LAN2 settings is returned.

| Settings  |          |   |
|-----------|----------|---|
| Syntax    | Command  | :SYSTem:COMMunicate:LAN2:GATeway ip1,ip2,ip3,ip4  |
| Example   |          | :SYSTem:COMMunicate:LAN2:GATeway 192,168,1,100<br>:SYSTem:COMMunicate:LAN2:UPDate   |
| Query     |          |   |
| Syntax    | Query    | :SYSTem:COMMunicate:LAN2:GATeway?<br>:SYSTem:COMMunicate:LAN2:GATeway:PREPARation?  |
|           | Response | ip1<NR1>,ip2<NR1>,ip3<NR1>,ip4<NR1>   |
| Example   |          | :SYSTem:COMMunicate:LAN2:GATeway?<br>(Response) :SYSTem:COMMunicate:LAN2:GATeway 192,168,1,100<br>(When the header is ON) |
| Parameter |          |   |
| ip1       | 0 to 255 |   |
| ip2       | 0 to 255 |   |
| ip3       | 0 to 255 |   |
| ip4       | 0 to 255 |   |

#### Change the PC to be used or change the IP address of the PC (as needed).

- If the intended use of the PC is only to set the IP address of the instrument, replace the PC as needed.
- Change the IP address of the PC as well if it becomes necessary as a result of setting the IP address of the instrument.

## 12.8 Outputting the Measured Value Using LAN2

The measured value of the instrument is output in real time.

The communication protocol is UDP.

All of the measurement ON channels are output at the recording intervals.

Performing the appropriate settings on the primary unit enables output of all measured values of the synchronized units of LR8102. (p.287)

There may be a delay depending on the performance or operating system of the receiving device.

As the protocol is UDP, receiving of all packets is not guaranteed.

To improve real-time performance, turn off the numerical calculation, alarm, and stop trigger functions.

### 1 Enable the measured value output function.

| Settings                |  |                   |
|-------------------------|--|-------------------|
| Syntax                  | Command  | :SYSTem:RTOut A\$ |
| Example                 | :SYSTem:RTOut LAN2udp  |                   |
| Query                   |  |                   |
| Syntax                  | Query  | :SYSTem:RTOut?    |
|                         | Response   | A\$               |
| Example                 | :SYSTem:RTOut?<br>(Response) :SYSTEM:RTOUT LAN2UDP (When the header is ON) |                   |
| Parameter               |  |                   |
| A\$ = OFF, CAN, LAN2udp |  |                   |
| OFF <sup>□</sup>        | Does not output the data from CAN or LAN2.                                 |                   |
| CAN                     | Outputs the data from the CAN terminal.                                    |                   |
| LAN2udp                 | Outputs the data from LAN2.  |                   |

If the instrument is controlled with XCP on Ethernet UDP, the data are not output regardless of the setting.

### 2 Set the IP address of the output destination.

The multicast communication is enabled by specifying the IP address for multicasting (224.0.0.0 to 239.255.255.255).

| Settings  |   |  |
|-----------|---|--|
| Syntax    | Command   | :SYSTem:COMMunicate:LAN2:SEND:IPAddress<br>ip1,ip2,ip3,ip4 |
| Example   | :SYSTem:COMMunicate:LAN2:SEND:IPAddress 192,168,1,100   |  |
| Query     |   |  |
| Syntax    | Query   | :SYSTem:COMMunicate:LAN2:SEND:IPAddress?                   |
|           | Response  | ip1<NR1>,ip2<NR1>,ip3<NR1>,ip4<NR1>                        |
| Example   | :SYSTem:COMMunicate:LAN2:SEND:IPAddress?<br>(Response) :SYSTEM:COMMUNICATE:LAN2:SEND:IPADDRESS 192,168,1,100<br>(When the header is ON) |  |
| Parameter |   |  |
| ip1       | 0 to 255  |  |
| ip2       | 0 to 255  |  |
| ip3       | 0 to 255  |  |
| ip4       | 0 to 255  |  |

### 3 Set the port number of the output destination.

| Settings             |          |   |
|----------------------|----------|---|
| Syntax               | Command  | :SYSTem:COMMunicate:LAN2:SEND:PORT no\$   |
| Example              |          | :SYSTem:COMMunicate:LAN2:SEND:PORT 10000  |
| Query                |          |   |
| Syntax               | Query    | :SYSTem:COMMunicate:LAN2:SEND:PORT?   |
|                      | Response | no\$  |
| Example              |          | :SYSTem:COMMunicate:LAN2:SEND:PORT?<br>(Response) :SYSTEM:COMMUNICATE:LAN2:SEND:PORT 10000<br>(When the header is ON) |
| Parameter            |          |   |
| no\$ = 1020 to 65535 |          |   |

### 4 Set the endianness.

| Settings          |   |  |
|-------------------|---|--|
| Syntax            | Command   | :SYSTem:COMMunicate:LAN2:SEND:ENDIAN A\$   |
| Example           |   | :SYSTem:COMMunicate:LAN2:SEND:ENDIAN LITTLE  |
| Query             |   |  |
| Syntax            | Query   | :SYSTem:COMMunicate:LAN2:SEND:ENDIAN?  |
|                   | Response  | A\$  |
| Example           |   | :SYSTem:COMMunicate:LAN2:SEND:ENDIAN?<br>(Response) :SYSTEM:COMMUNICATE:LAN2:SEND:ENDIAN LITTLE<br>(When the header is ON) |
| Parameter         |   |  |
| A\$ = LITTLE, BIG |   |  |
| LITTLE            | The format to send the higher-order byte first (little endian). |  |
| BIG <sup>□</sup>  | The format to send the lower-order byte first (big endian).     |  |

### 5 Set the data format of the measured value to be output.

| Settings                  |   |   |
|---------------------------|---|---|
| Syntax                    | Command                                       | :SYSTem:COMMunicate:LAN2:SEND:FORMat A\$  |
| Example                   |   | :SYSTem:COMMunicate:LAN2:SEND:FORMat INT32  |
| Query                     |   |   |
| Syntax                    | Query   | :SYSTem:COMMunicate:LAN2:SEND:FORMat?   |
|                           | Response                                      | A\$   |
| Example                   |   | :SYSTem:COMMunicate:LAN2:SEND:FORMat?<br>(Response) :SYSTEM:COMMUNICATE:LAN2:SEND:FORMAT INT32<br>(When the header is ON) |
| Parameter                 |   |   |
| A\$ = INT32, FLOAT, INDEX |   |   |
| INT32 <sup>□</sup>        | Signed, 32 bits, INT format                   |   |
| FLOAT                     | Single precision floating point number format |   |
| INDEX                     | Exponential notation (ASCII code)             |   |

The exponential notation is output with a character string. The data size per channel is increased and the number of measurement channels that can be output is decreased for the recording interval. Also, the exponential notation is output with a value rounded off to the number of display digits. If you want to acquire a value including a digit after the display digits, convert the value acquired by specifying the INT32 format into a physical quantity.

See "Conversion method from data in the INT32 format to physical quantities." (p. 290).

**6** (For primary unit)

Set whether or not to output the data in all secondary units.

| Settings         |   |  |
|------------------|---|--|
| Syntax           | Command   | :SYSTem:COMMunicate:LAN2:SEND:SYNC A\$   |
| Example          |   | :SYSTem:COMMunicate:LAN2:SEND:SYNC ON  |
| Query            |   |  |
| Syntax           | Query   | :SYSTem:COMMunicate:LAN2:SEND:SYNC?  |
|                  | Response  | A\$  |
| Example          |   | :SYSTem:COMMunicate:LAN2:SEND:SYNC?<br>(Response) :SYSTEM:COMMUNICATE:LAN2:SEND:SYNC ON<br>(When the header is ON) |
| Parameter        |   |  |
| A\$ = OFF, ON    |   |  |
| OFF <sup>☑</sup> | When this instrument is the primary unit, no data from any secondary unit are output from LAN2 of this instrument.  |  |
| ON               | When this instrument is the primary unit, the data of all secondary units are output from LAN2 of this instrument.<br>The output setting depends on the primary unit.<br>The data are output when the measured value output function of the primary unit is set to LAN2udp. |  |

## Data format

About the UDP data frame

| 1 byte        | 1 byte                             | 1 byte                          | 1 byte                      | 8 bytes                 | 4 bytes   | Variable length  | 1 byte                 | 1 byte        |
|---------------|------------------------------------|---------------------------------|-----------------------------|-------------------------|-----------|------------------|------------------------|---------------|
| Header (0xFE) | Synchronization number (0 or more) | Number of fragments (0 or more) | Fragment number (0 or more) | Data number (0 or more) | Data size | Measurement data | Checksum* <sup>1</sup> | Footer (0xFF) |

The data size of each channel type is as follows.

When the data format of the measured value is INT32 or FLOAT

| Channel type         | Data size              |
|----------------------|------------------------|
| Analog               | 4 bytes                |
| Pulse                | 4 bytes                |
| Logic                | 2 bytes (INT16 fixed)  |
| Alarm* <sup>1</sup>  | 2 bytes (INT16 fixed)  |
| Waveform calculation | 8 bytes (Double fixed) |

When the data format of the measured value is INDEX

| Channel type         | Data size |
|----------------------|-----------|
| Analog               | 12 bytes  |
| Pulse                | 12 bytes  |
| Logic                | 2 bytes   |
| Alarm* <sup>1</sup>  | 2 bytes   |
| Waveform calculation | 12 bytes  |

1 byte is added to the number of data points for all channels except for the last one, because a comma (,) is added between channels.

\*1. The alarm channel represents all channels (4 bit) by integers (starting from the lowest bit, output in order of alarm 1, alarm 2...). When the alarm channel data value is 9, alarm 1 and alarm 4 are output.



**Example:**

When the data format of the measured value is INT32 (when endian is set to BIG)  
See “Conversion method from data in the INT32 format to physical quantities.” (p. 290).

| Channel type         | Example of output data  | Decimal value         |
|----------------------|-------------------------|-----------------------|
| Analog               | ff ff 8c f1             | -29455                |
| Pulse                | 00 00 00 01             | 1                     |
| Logic                | 00 01                   | 1                     |
| Alarm                | 00 01                   | 1 (Alarm 1 is output) |
| Waveform calculation | bf 94 57 ce 1d 2e e4 f0 | -0.0198662            |

When the data format of the measured value is FLOAT (when endian is set to BIG)

| Channel type         | Example of output data  | Decimal value                      |
|----------------------|-------------------------|------------------------------------|
| Analog               | 3d 38 51 ec             | 0.045                              |
| Pulse                | 45 48 30 00             | 3203                               |
| Logic                | 00 01                   | 1                                  |
| Alarm                | 00 09                   | 9 (Alarm 1 and alarm 4 are output) |
| Waveform calculation | bf 94 57 ce 1d 2e e4 f0 | -0.0198662                         |

When the data format of the measured value is INDEX

| Channel type         | Example of output data              | ASCII code character |
|----------------------|-------------------------------------|----------------------|
| Analog               | 2d 31 2e 30 32 32 37 35 65 2d 30 32 | -1.02275e-02         |
| Pulse                | 2b 32 2e 33 30 30 30 30 65 2b 30 31 | +2.30000e+01         |
| Logic                | 30 31                               | 01                   |
| Alarm                | 31 35                               | 15                   |
| Waveform calculation | 2d 31 2e 37 36 32 30 32 65 2d 30 32 | -1.76202e-02         |

- The measurement data are sorted and output in the following order:  
analog, pulse, logic, alarm, and waveform calculation.
- For the same data size, the data are sorted by the module number in ascending order.
- For the same module number, the modules are sorted by the channel number in ascending order.

**Example:**

If the measurement ON channels are CH1\_1, CH1\_2, CH2\_1, PLS1, ALM, and W1, the data are sorted and output in the following order.

CH1\_1 → CH1\_2 → CH2\_1 → PLS1 → ALM → W1

The maximum packet size of the measurement data is 1454 byte per packet. If the size exceeds this value, the divided data are sent.

- \*1. Calculation range: Synchronization number to measurement data part  
Method: Lower-order 8 bits of the value calculated by simple addition of every 8 bits.

See “14.12 Data Handling” (p. 336).

## Conversion method from data in the INT32 format to physical quantities.

Perform the following calculation using the coefficient (table below) determined by the input type and the range setting of each channel.

Physical quantity = Received measurement data × Coefficient

In addition, perform the following calculation if the scaling is set.

Measured value = Physical quantity × Scaling coefficient + Scaling offset value

| Product name   | Mode or sensor | Range (f.s.)  | Coefficient |            |
|--|----------------|---------------|-------------|------------|
| <ul style="list-style-type: none"> <li>• M7100 Voltage/Temp Module (15 channels)</li> <li>• M7102 Voltage/Temp Module (30 channels)</li> </ul> | Voltage        | 10 mV         | 1.0000E-07  |            |
|  |                | 20 mV         | 2.0000E-07  |            |
|  |                | 100 mV        | 1.0000E-06  |            |
|  |                | 200 mV        | 2.0000E-06  |            |
|  |                | 1 V           | 1.0000E-05  |            |
|  |                | 2 V           | 2.0000E-05  |            |
|  |                | 6 V           | 6.0000E-05  |            |
|  |                | 10 V          | 1.0000E-04  |            |
|  |                | 20 V          | 2.0000E-04  |            |
|  |                | 60 V          | 6.0000E-04  |            |
|  |                | 100 V         | 1.0000E-03  |            |
|  |                | 1-5 V         | 6.0000E-05  |            |
|  |                | Thermocouples | 100°C       | 1.0000E-02 |
|  |                |               | 500°C       | 5.0000E-02 |
| 2000°C   | 1.0000E-01     |               |             |            |

## Measured value output function in synchronization

When multiple units are in synchronization, the primary unit can output the measured value of each secondary unit via UDP.

The output interval depends on each device.

## Number of channels that can be output during each recording interval

When the measured value output function is ON, there is a limit on the number of channels to be output for each setting.

See the table below for the limit of each setting.

If the number of channels exceeds the output limit of the measurement data, blank data is output.

When the output format is INT32 or FLOAT

| Synchronization  | Data format | Limited   |
|------------------|-------------|-----------|
| OFF              | INT32       | None      |
|                  | FLOAT       | None      |
|                  | Exponent    | None      |
| ON* <sup>1</sup> | INT32       | None      |
|                  | FLOAT       | None      |
|                  | Exponent    | No output |

- \*1. Synchronization is activated when the data of all secondary units are output from the primary units (:SYSTEM:COMMunicate:LAN2:SEND:SYNC ON). When the data are output from each primary and secondary unit (:SYSTEM:COMMunicate:LAN2:SEND:SYNC OFF), the synchronization is deactivated and the limit for "Synchronization: OFF" in the above table applies, even when the synchronous setting is set to ON.



### UDP receiving system

A sample program of the system in which data are received using the measured-value output function is included on the provided DVD.

When the sample program is executed, the measured value of LR8102 is received with UDP, converted to a physical quantity for each output format, and then saved in a file.



# 13 Specifications

## 13.1 Specifications of Data Logger

### General Specifications

#### Basic specifications

|   |  |
|---|--|
| <b>Product warranty duration</b>                      | 3 years  |
| <b>Accuracy warranty duration</b>                     | 1 year   |
| <b>Maximum number of module connections</b>           | 10 units   |
| <b>Modules that can be connected</b>                  |  |
| <b>Measurement module</b>                             | M7100 Voltage/Temp Module (15 channels)<br>M7102 Voltage/Temp Module (30 channels)   |
| <b>Internal buffer memory</b>                         | Volatile memory 512 MB   |
| <b>Clock function</b>                                 | Auto calendar, automatic leap year adjustment, 24-hour clock   |
| <b>Clock accuracy (precision of start/stop times)</b> | ±1.0 s/day (at 23°C)<br>By connecting to an NTP server, the time can be synchronized with the NTP server   |
| <b>Time axis accuracy</b>                             | ±0.2 s/day (at 23°C)   |
| <b>Backup battery life</b>                            | 10 years or more for clock use (reference value at 23°C)   |
| <b>Operating environment</b>                          | Indoor use, pollution degree 2, altitude up to 2000 m (6562 ft.)   |
| <b>Operating temperature and humidity range</b>       | -10°C to 50°C (14°F to 122°F), 80% RH or less (non-condensing)   |
| <b>Storage temperature and humidity range</b>         | -20°C to 60°C (-4°F to 140°F), 80% RH or less (non-condensing)   |
| <b>Dimensions</b>                                     | No module<br>Approx. 80W × 166H × 238D mm (3.2W × 6.5H × 9.4D in.) (excluding protruding parts)<br>With one M7100 installed<br>Approx. 134W × 166H × 263D mm (5.3W × 6.5H × 10.4D in.) (excluding protruding parts)<br>With ten M7100 installed<br>Approx. 620W × 166H × 263D mm (24.4W × 6.5H × 10.4D in.) (excluding protruding parts) |
| <b>Weight</b>   | Approx. 1.5 kg (3.3 lbs)   |
| <b>Standards</b>                                      | Safety: EN 61010<br>EMC: EN 61326  |

#### Display area

|                   |   |
|-------------------|---|
| <b>Status LED</b> | LR8101: POWER, ALARM, ERROR, START, ACCESS<br>LR8102: POWER, ALARM, ERROR, START, ACCESS, ACT, TERM |
|-------------------|---|

## Power

| Power                           |  |
|---------------------------------|--|
| <b>AC adapter</b>               | Z1016 AC Adapter (operates on 12 V DC $\pm 10\%$ )<br>Rated supply voltage: 100 V AC to 240 V AC (assuming voltage fluctuations of $\pm 10\%$ )<br>Rated power-supply frequency: 50 Hz/60 Hz |
| <b>External power supply</b>    | 10 V DC to 30 V DC   |
| Power consumption               |  |
| <b>Normal power consumption</b> | When Z1016 AC Adapter or 12 V DC external power supply is used, when one unit of M7100 or M7102 installed: 15 W (instrument only)  |
| <b>Maximum rated power</b>      | When Z1016 AC Adapter is used: 100 VA (including the AC adapter)<br>When 30 V DC external power supply is used: 60 VA (instrument only)  |

## Interface specifications

| LAN interface              |  |
|----------------------------|--|
| <b>LAN</b>                 | IEEE802.3 Ethernet 100BASE-TX / 1000Base-T (automatic detection)<br>Supporting Auto MDI-X, DHCP, and DNS (LAN1) only   |
| <b>Connector</b>           | RJ-45  |
| <b>Number of LAN ports</b> | 1 (LR8101)<br>2 (LR8102)   |
| <b>LAN1 function</b>       | <p>Collecting data and setting recording conditions using Logger Utility</p> <p>Setting the initial IP address using Logger Utility</p> <p>Setting and controlling recording using communication commands</p> <p>Manually acquiring data using an FTP Server<br/>Acquiring files on an SD memory card and USB drive<br/>Supported protocol: FTP</p> <p>FTP data auto send (FTP client)<br/>Transferring files saved on an SD memory card or USB drive<br/>During measurement: Waveform file (binary, text, MDF)<br/>After measurement: Waveform file (binary, text, MDF), numerical calculation result file<br/>Supported protocols: FTP, FTPS</p> <p>HTTP server function<br/>Control mode (max. 1 unit)<br/>Displaying the current measured value, starting and stopping the measurement, setting comments, upgrading, setting communications, displaying error information<br/>Browsing mode (max. 4 units)<br/>Displaying the current measured value, displaying the measurement status, displaying comments, displaying error information<br/>Language setting Japanese or English</p> <p>XCP on Ethernet (TCP)<br/>Supporting only measurement mode of ECU measurement/compatible software ASAM e.V. MCD-1 XCP v 1.5.0 compliant</p> <p>NTP client function<br/>Synchronizing time with NTP server<br/>Regular synchronization interval: 1 hour, 1 day<br/>Synchronization function before measurement available</p> |

| <b>LAN2 function (LR8102 only)</b>                     | XCP on Ethernet (UDP)<br>Supporting only measurement mode of ECU measurement/compatible software ASAM e.V. MCD-1 XCP v 1.5.0 compliant   |     |                       |     |             |     |          |   |              |     |                       |   |             |    |                      |
|--|--|-----|-----------------------|-----|-------------|-----|----------|---|--------------|-----|-----------------------|---|-------------|----|----------------------|
|  | Measurement data output function<br>Measurement data can be output based on the UDP protocol<br>Primary unit can output measurement data of all synchronized units, if the synchronization is ON<br>Output period: Output at recording intervals   |     |                       |     |             |     |          |   |              |     |                       |   |             |    |                      |
| <b>USB interface (host)</b>                            |  |     |                       |     |             |     |          |   |              |     |                       |   |             |    |                      |
| <b>Standard compliance</b>                             | USB 2.0 compliant  |     |                       |     |             |     |          |   |              |     |                       |   |             |    |                      |
| <b>Connector</b>                                       | Series A receptacle  |     |                       |     |             |     |          |   |              |     |                       |   |             |    |                      |
| <b>Operation guaranteed options</b>                    | Z4006 USB Drive (16 GB)<br>Format type: FAT16, FAT32   |     |                       |     |             |     |          |   |              |     |                       |   |             |    |                      |
| <b>Device that can be connected</b>                    | USB drive  |     |                       |     |             |     |          |   |              |     |                       |   |             |    |                      |
| <b>SD card slot</b>                                    |  |     |                       |     |             |     |          |   |              |     |                       |   |             |    |                      |
| <b>Standard compliance</b>                             | SD standards compliant × 1<br>(SD memory card/SDHC memory card supported)  |     |                       |     |             |     |          |   |              |     |                       |   |             |    |                      |
| <b>Operation guaranteed option</b>                     | Z4001 (2 GB), Z4003 (8 GB)<br>Format type: FAT16, FAT32  |     |                       |     |             |     |          |   |              |     |                       |   |             |    |                      |
| <b>Optical synchronization interface (LR8102 only)</b> |  |     |                       |     |             |     |          |   |              |     |                       |   |             |    |                      |
| <b>Connector</b>                                       | SFP optical transceiver, Duplex-LC (2-core LC)   |     |                       |     |             |     |          |   |              |     |                       |   |             |    |                      |
| <b>Optical signal</b>                                  | 850 nm VCSEL, 1 Gbps   |     |                       |     |             |     |          |   |              |     |                       |   |             |    |                      |
| <b>Laser class</b>                                     | Class 1  |     |                       |     |             |     |          |   |              |     |                       |   |             |    |                      |
| <b>Compatible fiber</b>                                | 50 μm/125 μm multi-mode fiber equivalent   |     |                       |     |             |     |          |   |              |     |                       |   |             |    |                      |
| <b>Port</b>  | <table border="1"> <thead> <tr> <th>Pin</th> <th>Signal name</th> <th>I/O</th> <th>Function</th> </tr> </thead> <tbody> <tr> <td>1</td> <td>OPT.LINK OUT</td> <td>OUT</td> <td>Optical signal output</td> </tr> <tr> <td>2</td> <td>OPT.LINK IN</td> <td>IN</td> <td>Optical signal input</td> </tr> </tbody> </table> |     |                       | Pin | Signal name | I/O | Function | 1 | OPT.LINK OUT | OUT | Optical signal output | 2 | OPT.LINK IN | IN | Optical signal input |
| Pin  | Signal name  | I/O | Function              |     |             |     |          |   |              |     |                       |   |             |    |                      |
| 1  | OPT.LINK OUT   | OUT | Optical signal output |     |             |     |          |   |              |     |                       |   |             |    |                      |
| 2  | OPT.LINK IN  | IN  | Optical signal input  |     |             |     |          |   |              |     |                       |   |             |    |                      |
|  |  |     |                       |     |             |     |          |   |              |     |                       |   |             |    |                      |

## External control terminal

### Terminal block

|       |  |    |
|-------|--|----|
| GND   |  | 1  |
| PULSE |  | 2  |
| SMPL  |  | 3  |
| GND   |  | 4  |
| I/O 1 |  | 5  |
| I/O 2 |  | 6  |
| I/O 3 |  | 7  |
| I/O 4 |  | 8  |
| GND   |  | 9  |
| ALM 1 |  | 10 |
| ALM 2 |  | 11 |
| ALM 3 |  | 12 |
| ALM 4 |  | 13 |
| GND   |  | 14 |
| CAN_H |  | 15 |
| CAN_L |  | 16 |
| GND   |  | 17 |

### Push-button type terminal block

| Pin | Signal name                | I/O                 | Function   |
|-----|----------------------------|---------------------|--|
| 1   | GND                        | -                   | GND  |
| 2   | PULSE                      | IN                  | Pulse/logic input                                      |
| 3   | SMPL                       | IN                  | External sampling input                                |
| 4   | GND                        | -                   | GND  |
| 5   | I/O 1                      | IN/OUT              | External input and output 1                            |
| 6   | I/O 2                      | IN/OUT              | External input and output 2                            |
| 7   | I/O 3                      | IN/OUT              | External input and output 3                            |
| 8   | I/O 4                      | IN/OUT              | External input and output 4                            |
| 9   | GND                        | -                   | GND  |
| 10  | ALM1                       | OUT                 | Alarm output 1   |
| 11  | ALM2                       | OUT                 | Alarm output 2   |
| 12  | ALM3                       | OUT                 | Alarm output 3   |
| 13  | ALM4                       | OUT                 | Alarm output 4   |
| 14  | GND                        | -                   | GND  |
| 15  | N.C. / CAN_H* <sup>1</sup> | -/OUT* <sup>1</sup> | Not connected / CAN_H communication line* <sup>1</sup> |
| 16  | N.C. / CAN_L* <sup>1</sup> | -/OUT* <sup>1</sup> | Not connected / CAN_L communication line* <sup>1</sup> |
| 17  | GND                        | -                   | GND  |

\*1. Can be used as CAN terminal on LR8102 only

### Pulse/logic input

|                              |   |
|------------------------------|---|
| <b>Number of terminals</b>   | 1<br>Not isolated (ground shared with instrument)   |
| <b>Function</b>              | Pulse/logic input   |
| <b>Applicable input form</b> | No-voltage contact, open collector (PNP open collector requires an external resistor), or voltage input           |
| <b>Maximum input voltage</b> | 0 V DC to 42 V DC   |
| <b>Input resistance</b>      | 1.1 MΩ ±5%  |
| <b>Detection level</b>       | Can be switched between 2 levels.<br>High 1.0 V or more, Low 0 V to 0.5 V<br>High 4.0 V or more, Low 0 V to 1.5 V |

### External sampling input

|                                      |   |
|--------------------------------------|---|
| <b>Number of terminals</b>           | 1<br>Not isolated (ground shared with instrument)   |
| <b>Function</b>                      | External sampling   |
| <b>Input voltage</b>                 | 0 V DC to 10 V DC<br>High level 2.0 V to 10 V, Low level 0 V to 0.8 V   |
| <b>Slope</b>                         | Rise or fall can be selected  |
| <b>Filter</b>                        | Can be set to ON/OFF  |
| <b>Response pulse width</b>          | When filter is OFF: High period 100 μs or more,<br>Low period 100 μs or more<br>When filter is ON: High period 4 ms or more,<br>Low period 4 ms or more |
| <b>Max. external sampling period</b> | 5 ms  |



| <b>External input and output</b>   |  |
|------------------------------------|--|
| <b>Number of terminals</b>         | 4<br>Not isolated (ground shared with instrument)  |
| <b>When set to input</b>           | Function:<br>Can be selected from OFF, START, STOP, START/STOP, trigger input, and event input<br><br>Input voltage: 0 V DC to 10 V DC<br>High level 2.5 V to 10 V, Low level 0 V to 0.8 V<br><br>Slope:<br>Rise or fall can be selected<br><br>Response pulse width:<br>High period 2.5 ms or more, Low period 2.5 ms or more |
| <b>When set to output</b>          | Function: Can be selected from OFF and trigger output<br><br>Output type: Open drain output (with 5 V voltage output)<br><br>Output voltage:<br>High level 4.0 V to 5.0 V<br>Low level 0 V to 0.5 V<br><br>Max. switching capacity: 5 V DC to 10 V DC, 200 mA<br><br>Output pulse width (trigger output): 10 ms or more        |
| <b>Alarm output</b>                |  |
| <b>Number of terminals</b>         | 4<br>Not isolated (ground shared with instrument)  |
| <b>Function</b>                    | Alarm output   |
| <b>Output type</b>                 | Open drain output (with 5 V voltage output)  |
| <b>Output voltage</b>              | High level: 4.0 V to 5.0 V, Low level: 0 V to 0.5 V<br>High and Low levels can be switched   |
| <b>Maximum switching capacity</b>  | 5 V DC to 30 V DC, 200 mA  |
| <b>Output pulse width</b>          | 10 ms or more  |
| <b>CAN interface (LR8102 only)</b> |  |
| <b>Number of ports</b>             | 1 port   |
| <b>Function</b>                    | Measured value output  |
| <b>Physical layer</b>              | ISO 11898 (High speed)<br>Not isolated (ground shared with instrument)   |
| <b>Supported protocol</b>          | CAN/CAN FD (ISO 11898-1:2015 compliant)  |
| <b>Terminator</b>                  | Can be set to ON/OFF<br>Resistance: 120 $\Omega$ $\pm$ 10 $\Omega$   |
| <b>Baud rate</b>                   | CAN/CAN FD (arbitration): 50 k, 62.5 k, 83.3 k, 100 k, 125 k, 250 k, 500 k, 800 k, 1000 k [Baud]<br>CAN FD (data): 0.5 M, 1 M, 2 M, 2.5 M, 4 M, 5 M [Baud]   |
| <b>GND terminal</b>                | Number of terminals 5 (shared ground)  |

## Recording

|                                  |  |
|----------------------------------|--|
| <b>REC mode</b>                  | Normal<br>Ext. sampling  |
| <b>Recording interval</b>        | 5 ms, 10 ms, 20 ms, 50 ms, 100 ms, 200 ms, 500 ms, 1 s, 2 s, 5 s, 10 s, 20 s, 30 s,<br>1 min, 2 min, 5 min, 10 min, 20 min, 30 min, 1 h<br>External  |
| <b>Data refresh interval</b>     | Can set a value for each module automatically or as desired<br>Automatic: The best data refresh interval is automatically selected according to the recording interval settings<br>Any value: Allowable settings must comply with module specifications  |
| <b>Repetitive recording</b>      | ON/OFF selection<br>ON: Resume recording after recording is stopped (stopped under stop trigger condition or when measurement is completed for recording time). Recording is repeated until it is stopped.<br>OFF: Recording one time until stopped.   |
| <b>Specified time/continuous</b> | Specified time: Recording time is set with days, hours, minutes, and seconds.<br>Can be set up to max. capacity of internal buffer memory (total 512 MB)<br>Continuous: Recording is performed until stopped.<br>Internal buffer memory is overwritten if max. capacity of internal buffer memory is exceeded.<br>Number of samples : Set with number of samples when external sampling is performed.  |
| <b>Waveform storage</b>          | Final 512 MB (512 M / n data) is saved to internal buffer memory<br><br>Calculation formula for data length (n) per sampling<br><br>$n = \text{Number of analog channels}^{*1} \times 4$ $+ \text{Number of pulse channels} \times 4$ $+ \text{Number of logic channels} \times 2$ $+ \text{Number of waveform calculation channels} \times 8$ $+ \text{Alarm}^{*2} \times 2$<br>*1. Applicable to measurement channels on M7100 or M7102<br>*2. Added only when alarm is used |
| <b>Recorded data backup</b>      | None   |

## File

### Save

|   |   |
|---|---|
| <b>Saving destination</b>                                     | Select SD memory card or USB drive  |
| <b>File name to be saved</b>                                  | Up to 8 single-byte characters<br>Selectable options include automatic serial numbering, date attachment, and comment attachment  |
| <b>Auto save</b>  |   |
| <b>Waveform data (Realtime save)</b>                          | Selectable options include OFF, binary format, text format, and MDF format  |
| <b>Numerical calculation results (saving after recording)</b> | Selectable from OFF and text format<br>When text format is selected, "Single file" (all calculations in one file) or "Individual calc" (separate file for each calculation) can be selected.  |
| <b>Media (Preferred saving destination)</b>                   | Select SD memory card or USB drive<br>When both an SD memory card and a USB drive are inserted, you can select the preferred saving destination.  |
| <b>Deleting</b>   | ON/OFF selection<br>OFF: Stops saving when the SD memory card or USB drive runs low on free space.<br>ON: Continues saving by deleting the oldest waveform file (binary, text, MDF) if the SD memory card or USB drive runs low on free space.<br>When both the SD memory card and USB drive are inserted, the deleting operation are performed only on the preferred saving destination medium.  |
| <b>Folder splitting</b>                                       | Select from disabled, 1 day, 1 week, and 1 month  |
| <b>File splitting</b>   | Select from division disabled, enabled, and divided on time.<br>Disable: Saves one set of recorded data in one file.<br>Enable: Divides data and switches to a new destination file for saving every time the specified time elapses after measurement starts.<br>Split time: Specify with days, hours, and minutes<br>Timed: Sets the reference time and switches to a new destination file for saving every time the division time elapses, starting from the reference time.<br>Reference time: Specify with hours and minutes<br>Split time: 1 min, 2 min, 5 min, 10 min, 15 min, 20 min, 30 min, 1 h, 2 h, 3 h, 4 h, 6 h, 8 h, 12 h, 1 day |
| <b>Data protection</b>  | If a power failure occurs while a file is being saved to the media, close the file before shutting down the power supply (enabled max. 30 minutes or more after the power is turned ON)   |
| <b>Manual save</b>  | Saves one of the following with the communication command.<br>Settings data, Waveform data (binary format), Waveform data (text format), Waveform data (MDF format), A2L file, Numerical calculation results (Single file, Individual calc)   |
| <b>Downsampling (text format only)</b>                        |   |
| <b>Downsampling</b>   | Select from OFF or 1/2 to 1/100,000   |
| <b>Save data</b>  | Selectable from instant value and statistical value<br>When statistical value is selected: Saves the instant, maximum, minimum, and average values within the downsampling interval as data   |
| <b>Load</b>   |   |
|   | Can load setting conditions using communication commands  |

## Calculation

| Numerical calculation                      |   |
|--|---|
| <b>Number of calculations</b>              | Up to 10 calculations can be performed simultaneously   |
| <b>Calculation details</b>                 | Average, P-P, Maximum, Time to max, Minimum, Time to min, Integration* <sup>1</sup> , Aggregation* <sup>1</sup> , Usage ratio* <sup>2</sup> , ON time* <sup>2</sup> , OFF time* <sup>2</sup> , ON count* <sup>2</sup> , OFF count* <sup>2</sup><br>*1. Selectable from Total, Positive, Negative, and ASB (absolute value)<br>*2. Can set the threshold value for each channel  |
| <b>Calculation period</b>                  | During recording: Performs calculation for all data being recorded  |
| <b>Time split calculation</b>              | Select from division disabled, enabled, and divided on time.<br>Disable: Performs calculation for all data being recorded<br>Enable: Performs calculation every time after division time elapses since measurement start time<br>Split time: Specify with days, hours, and minutes<br>Timed: Sets the reference time. Performs calculation every time after division time elapses starting from the reference time<br>Reference time: Specify with hours and minutes<br>Split time: 1 min, 2 min, 5 min, 10 min, 15 min, 20 min, 30 min, 1 h, 2 h, 3 h, 4 h, 6 h, 8 h, 12 h, 1 day      |
| Waveform calculation                       |   |
| <b>Calculation details</b>                 | The following calculations can be set:<br>• The four arithmetic operations between channels* <sup>3</sup><br>• Moving average, simple average, aggregation, and integration<br>Calculation results are recorded as data in calculation channels (W1 to W30). (Calculations are performed simultaneously with measurement. Recalculation cannot be performed after measurement.)<br>*3. Formula<br>(A * CHa □ B * CHb □ C * CHc □ D * CHd) ■ E<br>A, B, C, D, E: Any constant<br>CHa, CHb, CHc, CHd: Any measurement channels<br>□: One of +, -, *, and /<br>■: One of +, -, *, /, and ^ |
| Trigger                                    |   |
| <b>Trigger method</b>                      | Digital comparison method   |
| <b>Trigger timing</b>                      | Start, Stop, Start & Stop   |
| <b>Trigger condition</b>                   | AND or OR of trigger sources, Interval trigger, and External trigger<br>Free run if trigger is OFF  |
| <b>Trigger source</b>                      | Analog, Pulse, Logic, Wave calc   |
| Trigger type                               |   |
| <b>Analog, Pulse, waveform calculation</b> | Level trigger: Trigger is activated at a rise or fall across the specified level value<br>Window trigger: Specifies upper and lower limit values of the trigger level<br>Trigger is activated when entering or exiting the area   |
| <b>Logic</b>                               | Trigger is activated when 1 or 0 is matched   |
| <b>External trigger</b>                    | Trigger is activated at a rise or fall of external input signal<br>Rise or fall can be selected   |
| <b>Trigger response time</b>               | Data refresh interval × 3 + 5 ms  |
| <b>Trigger level resolution</b>            | (Analog) 0.1% f.s.<br>(Pulse) count 1 c, rotation speed 1/n (n is setting value for number of pulses per rotation)  |
| <b>Pre-trigger</b>                         | Set days, hours, minutes, and seconds<br>Can be set for realtime save as well   |

## Alarm

|  |  |
|--|--|
| <b>Alarm condition</b>                     | Separately set for ALM1 to ALM4<br>Alarm is triggered if one of the following conditions is met. <ul style="list-style-type: none"> <li>• AND or OR of alarm sources</li> <li>• Tc Burn out (thermocouple wire break)</li> </ul>   |
| <b>Alarm source</b>                        | Analog, Pulse, Logic, Wave calc  |
| <b>Thermocouple wire break</b>             | An alarm is triggered when a thermocouple wire break occurs (if thermocouple wire break detection is set to ON)  |
| <b>Alarm type</b>                          |  |
| <b>Analog, Pulse, waveform calculation</b> | <p>Level:<br/>An alarm is triggered at a rise or fall across the specified level value</p> <hr/> <p>Window:<br/>Set the upper and lower limit values<br/>An alarm is triggered when the specified signal enters or exits the area</p> <hr/> <p>Slope:<br/>Set the level and time<br/>An alarm is triggered when specified rate of change (level/time) is exceeded for a specified time.</p> <hr/> <p>Amount of change:<br/>Set the level, time, and slope<br/>An alarm is triggered when the amount of change within the specified width is equal to or greater or less than the specified level value</p> |
| <b>Logic</b>                               | An alarm is triggered when 1 or 0 is matched   |
| <b>Alarm filter</b>                        | A filter is applied to the result of either the AND or OR operation among the alarm sources.<br>Set with number of samples (OFF, 2 to 1000)<br>An alarm is triggered if the alarm status continues for the specified number of samples   |
| <b>Alarm setting resolution</b>            | (Analog) 0.1% f.s.<br>(Pulse) count 1 c, rotation speed 1/n (n is setting value for number of pulses per rotation)   |
| <b>Alarm hold</b>                          | ON/OFF selection<br>Alarm clear: Cancels the alarm without stopping the recording when the alarm hold is ON  |
| <b>Alarm buzzer</b>                        | ON/OFF selection   |
| <b>Alarm output response time</b>          | Data refresh interval × 3 + 5 ms   |

## Pulse input, logic input

**Pulse input** Measurement range, maximum resolution, measuring range, measurement accuracy

| Measurement target  | Range                  | Maximum resolution | Measurement range              | Measurement accuracy |
|---|------------------------|--------------------|--------------------------------|----------------------|
| Count   | 1000 M counts f.s.     | 1 count            | 0 count to 1000 M counts       | ±1 count             |
| Rotation speed  | 5,000/n (r/s) f.s.     | 1/n (r/s)          | 0 (r/s) to 5000/n (r/s)        | ±1/n (r/s)           |
|   | 300,000/n (r/min) f.s. | 60/t0·n (r/min)    | 0 (r/min) to 300,000/n (r/min) | ±60/t0·n (r/min)     |
| “n” is the number of pulses per one rotation between 1 and 1000<br>“t0” is the smoothing setting between 1 and 60 (s) |                        |                    |                                |                      |

|                                     |  |
|-------------------------------------|--|
| <b>Pulse input cycle</b>            | When filter is OFF:<br>200 $\mu$ s or more (must be 100 $\mu$ s or more in both H period and L period)<br>When filter is ON:<br>100 ms or more (must be 50 ms or more in both H period and L period) |
| <b>Slope</b>                        | Can be set to rise or fall   |
| <b>Measurement mode</b>             | Count (addition, instant), rotation speed  |
| <b>Count</b>                        | Addition: Counts the integrated value after the measurement is started<br>Instant: Counts the instant value at recording intervals (integrated value is reset at recording intervals)                |
| <b>Rotation speed</b>               | r/s: The number of input pulses per second is counted to calculate the rotation speed.<br>r/min: The number of input pulses per minute is counted to calculate the rotation speed.                   |
| <b>Smoothing function</b>           | Can be selected between 1 s and 60 s (can be set when rotation speed is r/min only)  |
| <b>Chattering prevention filter</b> | Can be set to ON/OFF   |
| <b>Logic input</b>                  |  |
| <b>Measurement mode</b>             | Record 1 or 0 at recording intervals   |

## Synchronous operation (LR8102 only)

|  |   |
|--|---|
| <b>Synchronization method</b>                        | Multiple units of the instrument can be operated synchronously<br>Assign one unit to the primary unit. Assign other units to the secondary units. |
| <b>Max. number of units that can be synchronized</b> | 10 units  |
| <b>Allowable recording interval setting</b>          | 5 ms or more  |
| <b>Synchronization error</b>                         | 20 $\mu$ s or less  |

## Other functions

|   |   |
|---|---|
| <b>Event mark function</b>                                    |   |
| <b>Event mark input method</b>                                | Event marks are input in the following events that have occurred during recording.<br>The following operations are performed during recording.<br>(1) Signal input to external input terminal<br>(2) Input while an alarm has occurred (can be set to ON/OFF)<br>(3) Using the corresponding communication commands   |
| <b>Number of inputs</b>                                       | Up to 1000 can be input per measurement   |
| <b>Scaling function</b>                                       | Scaling can be set for each channel<br>(Analog* <sup>1</sup> ) Options include setting by conversion ratio, setting with two points, or setting based on sensitivity.<br>(Pulse count) Configurable either by the number of pulses or by the number of counts.<br>(Pulse rotation speed) Configurable either by conversion ratio or by setting with two points.<br>*1. Measurement channels on M7100 or M7102 |
| <b>Comment entry function</b>                                 | Can enter comments for title and each channel (numerical values, alphabetical characters, and symbols)  |
| <b>Start backup function</b>                                  | ON/OFF selection<br>If this function is set to ON, the start status is automatically recovered and the recording is started (or the trigger standby state if the trigger is used) when the power is restored after shutdown during recording operation.   |
| <b>Beep sound</b>   | ON/OFF selection  |
| <b>Self-check function</b>                                    | Can check ROM/RAM, media, and modules   |
| <b>Horizontal (time) axis display</b>                         | Horizontal (time) axis display can be selected from among the time, date, and number of data points.<br>It takes effect during text format saving.  |
| <b>Measurement start and stop time specification function</b> | Measurement start and stop conditions can be set.<br>Specified date<br>Start time and stop time can be set (year, month, day, hour, minute).  |
| <b>Power-supply frequency filter function</b>                 | Select 50 Hz or 60 Hz   |

## Included accessories, options

|                             |            |
|-----------------------------|------------|
| <b>Included accessories</b> | See p. 10. |
| <b>Options</b>              | See p. 11. |

## 13.2 Specifications of Modules

### M7100 Voltage/Temp Module

#### General Specifications

|   |   |
|---|---|
| <b>Operating environment</b>                    | Indoor use, pollution degree 2, altitude up to 2000 m (6562 ft.)  |
| <b>Operating temperature and humidity range</b> | -10°C to 50°C (14°F to 122°F), 80% RH or less (non-condensing)  |
| <b>Storage temperature and humidity range</b>   | -20°C to 60°C (-4°F to 140°F), 80% RH or less (non-condensing)  |
| <b>Standards</b>                                | Safety: EN 61010<br>EMC: EN 61326 Class A   |
| <b>Standard compliance</b>                      | Thermocouple JIS C1602:2015, IEC60584-1:2013  |
| <b>Withstand voltage</b>                        | 7.4 kV AC for 1 minute (sensitivity current 1 mA)<br>Between input channels (+, -) and LR8101 or LR8102, between modules<br>350 V AC for 1 minute (sensitivity current 1 mA), between input channels (+, -) |
| <b>Normal power consumption</b>                 | 2.9 W (during measurement, data refresh interval is 10 ms, all channels are 10 mV f.s. range, measurement of all channels is ON)  |
| <b>Dimensions</b>                               | Approx. 53W × 166H × 263D mm (2.1W × 6.5H × 10.4D in.)  |
| <b>Weight</b>                                   | Approx. 1.3 kg (2.9 lbs)  |
| <b>Product warranty duration</b>                | 3 year  |
| <b>Included accessory</b>                       | Instruction Manual  |

#### Input specifications / Output specifications / Measurement specifications

##### -1. Basic specifications

|  |  |
|--|--|
| <b>Number of input channels</b>                  | 15 channels (voltage and thermocouple can be set for each channel)   |
| <b>Input terminal</b>                            | M3 screw type terminal block (2 terminals per channel), equipped with terminal block cover   |
| <b>Measurement target</b>                        | Voltage<br>Thermocouple (K, J, E, T, N, R, S, B, C)  |
| <b>Input method</b>                              | Scan method using semiconductor relays, floating unbalanced input<br>All channels isolated   |
| <b>A/D resolution</b>                            | 18 bits  |
| <b>Maximum input voltage</b>                     | ±100 V DC  |
| <b>Maximum voltage between the channels</b>      | 300 V DC   |
| <b>Maximum rated line-to-ground voltage</b>      | 1500 V DC in measurement category II, anticipated transient overvoltage 8000 V<br>1000 V AC in measurement category II, anticipated transient overvoltage 6000 V |
| <b>Maximum rated voltage between the modules</b> | 1500 V DC, 1000 V AC   |
| <b>Input resistance</b>                          | 100 MΩ or more (voltage 10 mV f.s. to 6 V f.s. range, 1-5 V f.s. range, thermocouple all ranges)<br>1 MΩ ±5% (voltage 10 V f.s. to 100 V f.s. range)             |
| <b>Allowable signal source resistance</b>        | 1 kΩ or less   |
| <b>RJC (Reference junction compensation)</b>     | Can be switched between internal and external (for thermocouple measurement).  |



|  |   |
|--|---|
| <b>Thermocouple wire break detection</b> | Wire break detection check for each data refresh interval during thermocouple measurement.<br>ON/OFF setting can be switched (batch setting on module)<br>Detection current 5 $\mu$ A $\pm$ 20%, no current while measurement data are acquired.<br>(Cannot be set when data refresh interval is 5 ms or 10 ms)                 |
| <b>Data refresh interval</b>             | 5 ms <sup>*1</sup> , 10 ms <sup>*2</sup> , 20 ms, 50 ms, 100 ms, 200 ms, 500 ms, 1 s, 2 s, 5 s, 10 s<br>*1.Can be selected when all measurement channels on the module are set to the voltage range and the number of channels being used is 1 to 8<br>*2. Can be selected when thermocouple wire break detection is set to OFF |
| <b>Digital filter</b>                    | The cutoff frequency of the digital filter is automatically set according to the data refresh interval, wire break detection setting, and power-supply frequency filter setting as shown in the table below.  |

–: Cannot be set

| Power-supply frequency filter setting | Wire break detection setting | Data refresh interval |        |        |        |        |        |        |     |     |     |      |
|---------------------------------------|------------------------------|-----------------------|--------|--------|--------|--------|--------|--------|-----|-----|-----|------|
|                                       |                              | 5 ms <sup>*3</sup>    | 10 ms  | 20 ms  | 50 ms  | 100 ms | 200 ms | 500 ms | 1 s | 2 s | 5 s | 10 s |
| 60 Hz                                 | OFF                          | 20.8 k                | 20.8 k | 6.94 k | 2.98 k | 2.42 k | 739    | 60     | 60  | 60  | 60  | 60   |
|                                       | ON                           | –                     | –      | 20.8 k | 6.94 k | 2.98 k | 2.42 k | 739    | 60  | 60  | 60  | 60   |
| 50 Hz                                 | OFF                          | 20.8 k                | 20.8 k | 6.94 k | 2.98 k | 2.42 k | 739    | 50     | 50  | 50  | 50  | 50   |
|                                       | ON                           | –                     | –      | 20.8 k | 6.94 k | 2.98 k | 2.42 k | 739    | 50  | 50  | 50  | 50   |

Unit: Hz

\*3.Can be selected when all measurement channels are set to the voltage range and the number of channels being used is 1 to 8

## -2. Accuracy specifications

|                                      |  |
|--------------------------------------|--|
| <b>Accuracy guarantee conditions</b> | Accuracy guarantee duration: 1 year<br>Accuracy guarantee temperature and humidity range: 23°C $\pm$ 5°C (73°F $\pm$ 9°F), 80% RH or less<br>Warm-up time: 30 minutes or longer after the LR8101 or LR8102 Data Logger is connected and the power is turned ON (However, when 4 or more modules are connected, a 10-minute warm-up time is added for the other modules whenever a module is added)<br>Determined for a setting that brings cutoff frequency to 50 Hz/60 Hz (see cutoff frequency table in “Digital filter” (p. 305)) after performing zero adjustment and also when the ambient temperature variation is within $\pm$ 5°C after the execution of zero adjustment |
|--------------------------------------|--|

| Measurement range / maximum resolution / measuring range / measurement accuracy | Measurement target | Type                       | Range       | Maximum resolution        | Measuring range             | Measurement accuracy |                             |        |
|---|--------------------|----------------------------|-------------|---------------------------|-----------------------------|----------------------|-----------------------------|--------|
| Voltage   | -                  |                            | 10 mV f.s.  | 100 nV                    | -10 mV to 10 mV             | ±15 µV               |                             |        |
|   |                    |                            | 20 mV f.s.  | 200 nV                    | -20 mV to 20 mV             | ±20 µV               |                             |        |
|   |                    |                            | 100 mV f.s. | 1 µV                      | -100 mV to 100 mV           | ±50 µV               |                             |        |
|   |                    |                            | 200 mV f.s. | 2 µV                      | -200 mV to 200 mV           | ±100 µV              |                             |        |
|   |                    |                            | 1 V f.s.    | 10 µV                     | -1 V to 1 V                 | ±500 µV              |                             |        |
|   |                    |                            | 2 V f.s.    | 20 µV                     | -2 V to 2 V                 | ±1 mV                |                             |        |
|   |                    |                            | 6 V f.s.    | 60 µV                     | -6 V to 6 V                 | ±3 mV                |                             |        |
|   |                    |                            | 10 V f.s.   | 100 µV                    | -10 V to 10 V               | ±5 mV                |                             |        |
|   |                    |                            | 20 V f.s.   | 200 µV                    | -20 V to 20 V               | ±10 mV               |                             |        |
|   |                    |                            | 60 V f.s.   | 600 µV                    | -60 V to 60 V               | ±30 mV               |                             |        |
|   |                    |                            | 100 V f.s.  | 1 mV                      | -100 V to 100 V             | ±50 mV               |                             |        |
| 1-5 V f.s.  | 60 µV              | 1 V to 5 V                 | ±3 mV       |                           |                             |                      |                             |        |
| Thermocouples (excluding reference junction compensation)                       | K                  |                            | 100°C f.s.  | 0.01°C                    | -100°C to 100°C             | ±0.5°C               |                             |        |
|   |                    |                            | 500°C f.s.  | 0.05°C                    | -200°C to lower than -100°C | ±1.2°C               |                             |        |
|   |                    |                            |             |                           | -100°C to 500°C             | ±0.5°C               |                             |        |
|   |                    |                            | 2000°C f.s. | 0.1°C                     | -200°C to lower than -100°C | ±1.2°C               |                             |        |
|   |                    |                            |             |                           | -100°C to lower than 500°C  | ±0.5°C               |                             |        |
|   |                    |                            |             |                           | 500°C to 1350°C             | ±0.8°C               |                             |        |
|   |                    |                            | 100°C f.s.  | 0.01°C                    | -100°C to 100°C             |                      | ±0.5°C                      |        |
|   |                    |                            |             |                           | 500°C f.s.                  | 0.05°C               | -200°C to lower than -100°C | ±0.9°C |
|   |                    |                            |             |                           |                             |                      | -100°C to 500°C             | ±0.5°C |
|   |                    |                            | 2000°C f.s. | 0.1°C                     | -200°C to lower than -100°C |                      | ±0.9°C                      |        |
|   |                    |                            |             |                           | -100°C to 1200°C            |                      | ±0.6°C                      |        |
|   |                    |                            | 100°C f.s.  | 0.01°C                    | -100°C to 100°C             |                      | ±0.5°C                      |        |
|   |                    |                            |             |                           | 500°C f.s.                  | 0.05°C               | -200°C to lower than -100°C | ±0.9°C |
|   |                    |                            |             |                           |                             |                      | -100°C to 500°C             | ±0.5°C |
|   |                    |                            | 2000°C f.s. | 0.1°C                     | -200°C to lower than -100°C |                      | ±0.9°C                      |        |
|   |                    |                            |             |                           | -100°C to 1000°C            |                      | ±0.5°C                      |        |
|   |                    |                            | 100°C f.s.  | 0.01°C                    | -100°C to 100°C             |                      | ±0.5°C                      |        |
|   |                    |                            |             |                           | 500°C f.s.                  | 0.05°C               | -200°C to lower than -100°C | ±1.2°C |
|   |                    |                            |             |                           |                             |                      | -100°C to 400°C             | ±0.5°C |
|   |                    |                            | 2000°C f.s. | 0.1°C                     | -200°C to lower than -100°C |                      | ±1.2°C                      |        |
|   |                    |                            |             |                           | -100°C to 400°C             |                      | ±0.5°C                      |        |
|   |                    |                            | 100°C f.s.  | 0.01°C                    | -100°C to lower than 0°C    |                      | ±1.0°C                      |        |
|   |                    |                            |             |                           | 0°C to 100°C                |                      | ±0.8°C                      |        |
|   |                    |                            |             |                           | 500°C f.s.                  | 0.05°C               | -200°C to lower than -100°C | ±1.6°C |
|   |                    |                            |             |                           |                             |                      | -100°C to lower than 0°C    | ±1.0°C |
|   |                    |                            |             |                           | 0°C to 500°C                |                      | ±0.8°C                      |        |
|   |                    |                            | 2000°C f.s. | 0.1°C                     | -200°C to lower than -100°C |                      | ±1.6°C                      |        |
|   |                    |                            |             |                           | -100°C to lower than 0°C    |                      | ±1.0°C                      |        |
|   |                    |                            |             |                           | 0°C to 1300°C               |                      | ±0.8°C                      |        |
|   |                    |                            | 100°C f.s.  | 0.01°C                    | 0°C to 100°C                |                      | ±3.5°C                      |        |
|   |                    |                            |             |                           | 500°C f.s.                  | 0.05°C               | 0°C to lower than 100°C     | ±3.5°C |
|   |                    |                            |             |                           |                             |                      | 100°C to lower than 300°C   | ±2.8°C |
|   |                    |                            |             |                           | 300°C to 500°C              |                      | ±2.1°C                      |        |
|   |                    |                            | 2000°C f.s. | 0.1°C                     | 0°C to lower than 100°C     |                      | ±3.5°C                      |        |
|   |                    |                            |             |                           | 100°C to lower than 300°C   |                      | ±2.8°C                      |        |
|   |                    |                            |             |                           | 300°C to 1700°C             |                      | ±2.1°C                      |        |
| 100°C f.s.  | 0.01°C             | 0°C to 100°C               |             | ±3.5°C                    |                             |                      |                             |        |
|   |                    | 500°C f.s.                 | 0.05°C      | 0°C to lower than 100°C   | ±3.5°C                      |                      |                             |        |
|   |                    |                            |             | 100°C to lower than 300°C | ±2.8°C                      |                      |                             |        |
|   |                    | 300°C to 500°C             |             | ±2.1°C                    |                             |                      |                             |        |
| 2000°C f.s.   | 0.1°C              | 0°C to lower than 100°C    |             | ±3.5°C                    |                             |                      |                             |        |
|   |                    | 100°C to lower than 300°C  |             | ±2.8°C                    |                             |                      |                             |        |
|   |                    | 300°C to 1700°C            |             | ±2.1°C                    |                             |                      |                             |        |
| 2000°C f.s.   | 0.1°C              | 400°C to lower than 600°C  |             | ±4.3°C                    |                             |                      |                             |        |
|   |                    | 600°C to lower than 1000°C |             | ±3.6°C                    |                             |                      |                             |        |
|   |                    | 1000°C to 1800°C           |             | ±2.3°C                    |                             |                      |                             |        |
| 100°C f.s.  | 0.01°C             | 0°C to 100°C               |             | ±1.6°C                    |                             |                      |                             |        |
|   |                    | 500°C f.s.                 | 0.05°C      | 0°C to 500°C              |                             | ±1.6°C               |                             |        |
|   |                    |                            |             | 2000°C f.s.               |                             | 0.1°C                | 0°C to 2000°C               | ±1.6°C |

Reference junction compensation accuracy

±0.5°C (when input terminal temperature is equilibrated)  
 Reference junction compensation: Added to the thermocouple measurement accuracy when set to internal

|   |   |
|---|---|
| <b>Temperature characteristics</b>                                | Add the following value to the measurement accuracy for operating temperature outside the accuracy guaranteed temperature range.<br>$\Delta T \times (\text{measurement accuracy} \times 0.1)$<br>$\Delta T$ : Temperature difference between operating temperature and upper or lower limit value of accuracy guaranteed temperature range (°C)<br>Add reference junction compensation accuracy to measurement accuracy when reference junction compensation is set to internal.   |
| <b>Normal mode removal ratio</b>                                  | 50 dB or more<br>(Power-supply frequency filter 50 Hz, data refresh interval 5 s, and thermocouple wire break detection OFF setting for 50 Hz input)<br>(Power-supply frequency filter 60 Hz, data refresh interval 5 s, and thermocouple wire break detection OFF setting for 60 Hz input)   |
| <b>Common mode removal ratio</b>                                  | 100 dB or more (signal source resistance of 100 $\Omega$ or less and data refresh interval of 10 ms for 50 Hz/60 Hz input)<br>140 dB or more (signal source resistance 100 $\Omega$ or less, power-supply frequency filter 50 Hz, data refresh interval 5 s, 10 mV f.s. range, and thermocouple wire break detection OFF setting for 50 Hz input)<br>(signal source resistance 100 $\Omega$ or less, power-supply frequency filter 60 Hz, data refresh interval 5 s, 10 mV f.s. range, and thermocouple wire break detection OFF setting for 60 Hz input) |
| <b>Effects of radiated radio-frequency electromagnetic field</b>  | $\pm 5\%$ f.s.<br>(80 MHz to 1 GHz: 10 V/m, 1 GHz to 6 GHz: 3 V/m, at voltage 10 V f.s. range)  |
| <b>Effects of conducted radio-frequency electromagnetic field</b> | $\pm 5\%$ f.s. at 10 V (voltage 10 V f.s. range)  |

## M7102 Voltage/Temp Module

### General Specifications

|   |   |
|---|---|
| <b>Operating environment</b>                    | Indoor use, pollution degree 2, altitude up to 2000 m (6562 ft.)  |
| <b>Operating temperature and humidity range</b> | -10°C to 50°C (14°F to 122°F), 80% RH or less (non-condensing)  |
| <b>Storage temperature and humidity range</b>   | -20°C to 60°C (-4°F to 140°F), 80% RH or less (non-condensing)  |
| <b>Standards</b>                                | Safety: EN 61010<br>EMC: EN 61326 Class A   |
| <b>Standard compliance</b>                      | Thermocouple JIS C1602:2015, IEC60584-1:2013  |
| <b>Withstand voltage</b>                        | 3.6 kV AC for 1 minute (sensitivity current 1 mA)<br>between input channels (+, -) and LR8101/LR8102, between modules<br>350 V AC for 1 minute (sensitivity current 1 mA) between input channels (+, -) |
| <b>Normal power consumption</b>                 | 2.7 W (during measurement, data refresh interval is 20 ms, all channels are 10 mV f.s. range, measurement of all channels is ON)  |
| <b>Dimensions</b>                               | Approx. 53W × 166H × 263D mm (2.1W × 6.5H × 10.4D in.)  |
| <b>Weight</b>                                   | Approx. 1.2 kg (2.6 lbs)  |
| <b>Product warranty duration</b>                | 3 years   |
| <b>Included accessory</b>                       | Instruction Manual  |

**Input specifications / Output specifications / Measurement specifications****-1. Basic specifications**

|  |  |
|--|--|
| <b>Number of input channels</b>                  | 30 channels (voltage and thermocouple can be set for each channel)   |
| <b>Input terminal</b>                            | Push-button type terminal block (2 terminals per channel), equipped with terminal block cover  |
| <b>Measurement target</b>                        | Voltage<br>Thermocouple (K, J, E, T, N, R, S, B, C)  |
| <b>Input method</b>                              | Scan method using semiconductor relays, floating unbalanced input<br>All channels isolated   |
| <b>A/D resolution</b>                            | 18 bits  |
| <b>Maximum input voltage</b>                     | ±100 V DC  |
| <b>Maximum voltage between the channels</b>      | 300 V DC   |
| <b>Maximum rated line-to-ground voltage</b>      | 600 V AC, DC in measurement category II, anticipated transient overvoltage<br>4000 V   |
| <b>Maximum rated voltage between the modules</b> | 600 V AC, DC   |
| <b>Input resistance</b>                          | 100 MΩ or more (voltage 10 mV f.s. to 6 V f.s. range, 1-5 V f.s. range, thermocouple all ranges)<br>1 MΩ ±5% (voltage 10 V f.s. to 100 V f.s. range)   |
| <b>Allowable signal source resistance</b>        | 1 kΩ or less   |
| <b>RJC (Reference junction compensation)</b>     | Can be switched between internal and external (for thermocouple measurement).  |
| <b>Thermocouple wire break detection</b>         | Wire break detection check for each data refresh interval during thermocouple measurement.<br>ON/OFF setting can be switched (batch setting on module)<br>Detection current 5 μA ±20%, no current while measurement data are acquired.<br>(Cannot be set when data refresh interval is 10 ms)  |
| <b>Data refresh interval</b>                     | 10 ms <sup>*1</sup> , 20 ms <sup>*2</sup> , 50 ms, 100 ms, 200 ms, 500 ms, 1 s, 2 s, 5 s, 10 s<br>*1.Can be selected when thermocouple wire break detection is set to OFF and the number of channels being used is 1 to 15<br>*2.Can be selected when thermocouple wire break detection is set to OFF, or when thermocouple wire break detection is set to ON and the number of channels being used is 1 to 15 |
| <b>Digital filter</b>                            | The cutoff frequency of the digital filter is automatically set according to the data refresh interval, wire break detection setting, and power-supply filter setting as shown in the following table.   |

- When the number of channels being used is 15 or less

–: Cannot be set

| Power-supply frequency filter setting | Wire break detection setting | Data refresh interval |        |        |        |        |        |     |     |     |      |
|---------------------------------------|------------------------------|-----------------------|--------|--------|--------|--------|--------|-----|-----|-----|------|
|                                       |                              | 10 ms                 | 20 ms  | 50 ms  | 100 ms | 200 ms | 500 ms | 1 s | 2 s | 5 s | 10 s |
| 60 Hz                                 | OFF                          | 20.8 k                | 6.94 k | 2.98 k | 2.42 k | 739    | 60     | 60  | 60  | 60  | 60   |
|                                       | ON                           | –                     | 20.8 k | 6.94 k | 2.98 k | 2.42 k | 739    | 60  | 60  | 60  | 60   |
| 50 Hz                                 | OFF                          | 20.8 k                | 6.94 k | 2.98 k | 2.42 k | 739    | 50     | 50  | 50  | 50  | 50   |
|                                       | ON                           | –                     | 20.8 k | 6.94 k | 2.98 k | 2.42 k | 739    | 50  | 50  | 50  | 50   |

Unit: Hz

- When the number of channels being used is 16 to 30

–: Cannot be set

| Power-supply frequency filter setting | Wire break detection setting | Data refresh interval |        |        |        |        |        |     |     |     |      |
|---------------------------------------|------------------------------|-----------------------|--------|--------|--------|--------|--------|-----|-----|-----|------|
|                                       |                              | 10 ms                 | 20 ms  | 50 ms  | 100 ms | 200 ms | 500 ms | 1 s | 2 s | 5 s | 10 s |
| 60 Hz                                 | OFF                          | –                     | 20.8 k | 6.94 k | 2.98 k | 2.42 k | 739    | 60  | 60  | 60  | 60   |
|                                       | ON                           | –                     | –      | 20.8 k | 6.94 k | 2.98 k | 2.42 k | 739 | 60  | 60  | 60   |
| 50 Hz                                 | OFF                          | –                     | 20.8 k | 6.94 k | 2.98 k | 2.42 k | 739    | 50  | 50  | 50  | 50   |
|                                       | ON                           | –                     | –      | 20.8 k | 6.94 k | 2.98 k | 2.42 k | 739 | 50  | 50  | 50   |

Unit: Hz

## -2. Accuracy specifications

### Accuracy guarantee conditions

Accuracy guarantee duration: 1 year

Accuracy guarantee temperature and humidity range: 23°C ±5°C (73°F ±9°F), 80% RH or less

Warm-up time: 30 minutes or longer after the LR8101 or LR8102 Data Logger is connected and the power is turned ON (However, when 4 or more modules are connected, a 10-minute warm-up time is added for the other modules whenever a module is added)

Determined for a setting that brings cutoff frequency to 50 Hz/60 Hz (see cutoff frequency table in “Digital filter” (p. 308)) after performing zero adjustment and also when the ambient temperature variation is within ±5°C after the execution of zero adjustment

| Measurement range / maximum resolution / measuring range / measurement accuracy | Measurement target          | Type        | Range                    | Maximum resolution          | Measuring range   | Measurement accuracy |
|---|-----------------------------|-------------|--------------------------|-----------------------------|-------------------|----------------------|
|   | Voltage                     | -           |                          | 10 mV f.s.                  | 100 nV            | -10 mV to 10 mV      |
| 20 mV f.s.  |                             |             |                          | 200 nV                      | -20 mV to 20 mV   | ±20 µV               |
| 100 mV f.s.   |                             |             |                          | 1 µV                        | -100 mV to 100 mV | ±50 µV               |
| 200 mV f.s.   |                             |             |                          | 2 µV                        | -200 mV to 200 mV | ±100 µV              |
| 1 V f.s.  |                             |             |                          | 10 µV                       | -1 V to 1 V       | ±500 µV              |
| 2 V f.s.  |                             |             |                          | 20 µV                       | -2 V to 2 V       | ±1 mV                |
| 6 V f.s.  |                             |             |                          | 60 µV                       | -6 V to 6 V       | ±3 mV                |
| 10 V f.s.   |                             |             |                          | 100 µV                      | -10 V to 10 V     | ±5 mV                |
| 20 V f.s.   |                             |             |                          | 200 µV                      | -20 V to 20 V     | ±10 mV               |
| 60 V f.s.   |                             |             |                          | 600 µV                      | -60 V to 60 V     | ±30 mV               |
| 100 V f.s.  |                             |             |                          | 1 mV                        | -100 V to 100 V   | ±50 mV               |
| 1-5 V f.s.  |                             |             |                          | 60 µV                       | 1 V to 5 V        | ±3 mV                |
| Thermocouples (excluding reference junction compensation)                       | K                           | 100°C f.s.  | 0.01°C                   | -100°C to 100°C             | ±0.5°C            |                      |
|   |                             |             |                          | -200°C to lower than -100°C | ±1.2°C            |                      |
|   |                             | 500°C f.s.  | 0.05°C                   | -100°C to 500°C             | ±0.5°C            |                      |
|   |                             |             |                          | -200°C to lower than -100°C | ±1.2°C            |                      |
|   |                             | 2000°C f.s. | 0.1°C                    | -100°C to lower than 500°C  | ±0.5°C            |                      |
|   |                             |             |                          | 500°C to 1350°C             | ±0.8°C            |                      |
|   | J                           | 100°C f.s.  | 0.01°C                   | -100°C to 100°C             | ±0.5°C            |                      |
|   |                             |             |                          | -200°C to lower than -100°C | ±0.9°C            |                      |
|   |                             | 500°C f.s.  | 0.05°C                   | -100°C to 500°C             | ±0.5°C            |                      |
|   | -200°C to lower than -100°C |             |                          | ±0.9°C                      |                   |                      |
|   | 2000°C f.s.                 | 0.1°C       | -100°C to 1200°C         | ±0.6°C                      |                   |                      |
|   |                             |             |                          |                             |                   |                      |
|   | E                           | 100°C f.s.  | 0.01°C                   | -100°C to 100°C             | ±0.5°C            |                      |
|   |                             |             |                          | -200°C to lower than -100°C | ±0.9°C            |                      |
|   |                             | 500°C f.s.  | 0.05°C                   | -100°C to 500°C             | ±0.5°C            |                      |
|   | -200°C to lower than -100°C |             |                          | ±0.9°C                      |                   |                      |
|   | 2000°C f.s.                 | 0.1°C       | -100°C to 1000°C         | ±0.5°C                      |                   |                      |
|   |                             |             |                          |                             |                   |                      |
|   | T                           | 100°C f.s.  | 0.01°C                   | -100°C to 100°C             | ±0.5°C            |                      |
|   |                             |             |                          | -200°C to lower than -100°C | ±1.2°C            |                      |
|   |                             | 500°C f.s.  | 0.05°C                   | -100°C to 400°C             | ±0.5°C            |                      |
|   | -200°C to lower than -100°C |             |                          | ±1.2°C                      |                   |                      |
|   | 2000°C f.s.                 | 0.1°C       | -100°C to 400°C          | ±0.5°C                      |                   |                      |
|   |                             |             |                          |                             |                   |                      |
|   | N                           | 100°C f.s.  | 0.01°C                   | -100°C to lower than 0°C    | ±1.0°C            |                      |
|   |                             |             |                          | 0°C to 100°C                | ±0.8°C            |                      |
|   |                             | 500°C f.s.  | 0.05°C                   | -200°C to lower than -100°C | ±1.6°C            |                      |
|   |                             |             |                          | -100°C to lower than 0°C    | ±1.0°C            |                      |
|   |                             | 2000°C f.s. | 0.1°C                    | 0°C to 500°C                | ±0.8°C            |                      |
|   | -200°C to lower than -100°C |             |                          | ±1.6°C                      |                   |                      |
|   |                             |             | -100°C to lower than 0°C | ±1.0°C                      |                   |                      |
|   |                             |             | 0°C to 1300°C            | ±0.8°C                      |                   |                      |
|   | R                           | 100°C f.s.  | 0.01°C                   | 0°C to 100°C                | ±3.5°C            |                      |
|   |                             |             |                          | 0°C to lower than 100°C     | ±3.5°C            |                      |
|   |                             | 500°C f.s.  | 0.05°C                   | 100°C to lower than 300°C   | ±2.8°C            |                      |
|   |                             |             |                          | 300°C to 500°C              | ±2.1°C            |                      |
|   |                             | 2000°C f.s. | 0.1°C                    | 0°C to lower than 100°C     | ±3.5°C            |                      |
|   | 100°C to lower than 300°C   |             |                          | ±2.8°C                      |                   |                      |
|   |                             |             | 300°C to 1700°C          | ±2.1°C                      |                   |                      |
|   | S                           | 100°C f.s.  | 0.01°C                   | 0°C to 100°C                | ±3.5°C            |                      |
|   |                             |             |                          | 0°C to lower than 100°C     | ±3.5°C            |                      |
|   |                             | 500°C f.s.  | 0.05°C                   | 100°C to lower than 300°C   | ±2.8°C            |                      |
|   |                             |             |                          | 300°C to 500°C              | ±2.1°C            |                      |
|   |                             | 2000°C f.s. | 0.1°C                    | 0°C to lower than 100°C     | ±3.5°C            |                      |
|   | 100°C to lower than 300°C   |             |                          | ±2.8°C                      |                   |                      |
|   |                             |             | 300°C to 1700°C          | ±2.1°C                      |                   |                      |
|   | B                           | 2000°C f.s. | 0.1°C                    | 400°C to lower than 600°C   | ±4.3°C            |                      |
|   |                             |             |                          | 600°C to lower than 1000°C  | ±3.6°C            |                      |
| 1000°C to 1800°C  |                             |             |                          | ±2.3°C                      |                   |                      |
| C   | 100°C f.s.                  | 0.01°C      | 0°C to 100°C             | ±1.6°C                      |                   |                      |
|   |                             |             | 0°C to 500°C             | ±1.6°C                      |                   |                      |
|   | 2000°C f.s.                 | 0.1°C       | 0°C to 2000°C            | ±1.6°C                      |                   |                      |

**Reference contact guaranteed accuracy** ±0.5°C (when input terminal temperature is equilibrated)  
 Reference junction compensation: Added to the thermocouple measurement accuracy when set to internal

|   |  |
|---|--|
| <b>Temperature characteristics</b>                                | <p>Add the following value to the measurement accuracy for operating temperature outside the accuracy guaranteed temperature range.</p> $\Delta T \times (\text{Measurement accuracy} \times 0.1)$ <p><math>\Delta T</math>: Temperature difference between operating temperature and upper or lower limit value of accuracy guaranteed temperature range (°C)</p> <p>Add reference junction compensation accuracy to measurement accuracy when reference junction compensation is set to internal.</p>  |
| <b>Normal mode removal ratio</b>                                  | <p>50 dB or more<br/>(Power-supply frequency filter 50 Hz, data refresh interval 5 s, thermocouple wire break detection OFF setting, number of channels being used is 15 or less for 50 Hz input)</p> <p>(Power-supply frequency filter 60 Hz, data refresh interval 5 s, thermocouple wire break detection OFF setting, number of channels being used is 15 or less for 60 Hz input)</p>  |
| <b>Common mode removal ratio</b>                                  | <p>100 dB or more<br/>(data refresh interval 10 ms, signal source resistance 100 <math>\Omega</math> or less, thermocouple wire break detection OFF setting, and number of channels being used is 15 or less for 50 Hz/60 Hz input)</p> <p>140 dB or more<br/>(power-frequency filter 50 Hz, data refresh interval 5 s, 10 mV f.s. range, signal source resistance 100 <math>\Omega</math> or less, thermocouple wire break detection OFF setting, and number of channels being used is 15 or less for 50 Hz input)</p> <p>(power-frequency filter 60 Hz, data refresh interval 5 s, 10 mV f.s. range, signal source resistance 100 <math>\Omega</math> or less, thermocouple wire break detection OFF setting, and number of channels being used is 15 or less for 60 Hz input)</p> |
| <b>Effects of radiated radio-frequency electromagnetic field</b>  | <p><math>\pm 5\%</math> f.s.<br/>(80 MHz to 1 GHz: 10 V/m, 1 GHz to 6 GHz: 3 V/m, at voltage 10 V f.s. range)</p>  |
| <b>Effects of conducted radio-frequency electromagnetic field</b> | <p><math>\pm 5\%</math> f.s. at 10 V (voltage 10 V f.s. range)</p>   |





# 14 Knowledge and Information

## 14.1 Measuring Temperature

Thermocouples are widely used for temperature measurement. This section describes precautions for using the thermocouples.

### Select a thermocouple appropriate to the measurement target

The following thermocouples can be used with the instrument.

| Thermocouples | Temperature range within which the limit deviation tolerance is specified in JIS C1602, IEC 60584-1 (°C) | Features  |
|---------------|--|---|
| K             | -40 to 1200  | Linear relationship between temperature and thermo-electromotive force. Most widely used in industry.   |
| J             | -40 to 750   | Electromotive force per 1°C is the second highest next to thermocouple E.   |
| E             | -40 to 900   | Thermo-electromotive force per 1°C is the highest. As a result, the effect of noise can be reduced.   |
| T             | -40 to 350   | Thermocouple with high electromotive force in a low temperature region between -40°C and 350°C. Used for high precis in low temperature regions.  |
| N             | -40 to 1200  | The thermo-electromotive force is stable from low to high temperatures. Used to measure high temperature regions inexpensively.   |
| R             | 0 to 1600  | Used for measurement in high temperature regions. Although the oxidation resistance and chemical resistance are excellent, this thermocouple is expensive.  |
| S             |  |   |
| B             | 600 to 1700  | Used for measurement in higher temperature regions than R and S. Since the electromotive force is very low, this thermocouple cannot be used for measurement in low and intermediate temperature regions. |
| C             | 426 to 2315  | This thermocouple can measure the highest temperature.  |

A physical phenomenon called short range ordering occurs in thermocouples K and E. Due to this phenomenon, the thermo-electromotive force is gradually increased from 250°C to 600°C, possibly causing a significant error in a relatively short time (within 1 hour). Since this phenomenon is originated with physical properties, it is unavoidable. Once the thermo-electromotive force of thermocouple is increased, the normal value cannot be recovered even if the temperature is decreased. To recover the original thermo-electromotive force curve, it is necessary to increase the temperature to 650°C or higher.

Select the thermocouples while referring to the manufacturer of the thermocouples to be used.

### **Error due to heat dissipation on a thermocouple**

By attaching a thermocouple, heat is dissipated (transferred) from the measurement target via the thermocouple. If the amount of heat dissipation to the thermocouple is large, the measurement result can deviate from the actual temperature.

When thermocouples K and T are compared, the heat dissipation on thermocouple T is larger because the heat conduction is higher.

In addition, the larger the thermocouple diameter, the larger the heat dissipation on the thermocouple.

For temperature measurement of smaller parts, thermocouple K with a small diameter is recommended.

### **Closely attach a thermocouple to the measurement target**

To measure the temperature with high precision, closely attach the thermocouple tip to the measurement target.

If the contact between the thermocouple and the measurement target is small, the heat transfer to the thermocouple is reduced and the measurement result can deviate from the actual temperature.

For a large measurement target, the heat dissipation from the thermocouple can be reduced by placing the part of the thermocouple adjacent to the tip in contact with the measurement target.

## 14.2 Digital Filter Characteristics

M7100 and M7102 Voltage/Temp Module are equipped with a digital filter. The cutoff frequency is automatically set according to the type of measurement module, number of channels being used, data refresh interval, power-supply frequency filter, and wire break detection setting.

If it is necessary to remove the power-supply line frequency, a high noise removing performance can be achieved by configuring the settings so that the cutoff frequency matches the power-supply line frequency. For the cutoff frequency, see the section for the digital filter of the modules in “13.2 Specifications of Modules” (p. 304).

The figures below show a typical example of the digital filter characteristics when the data refresh interval is 10 s in the M7100 and M7102.

### Cutoff frequency: 50 Hz

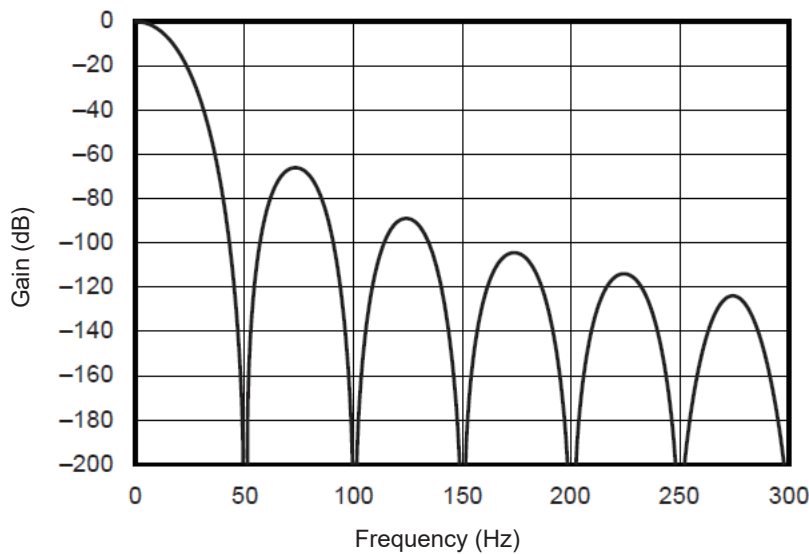

### Cutoff frequency: 60 Hz

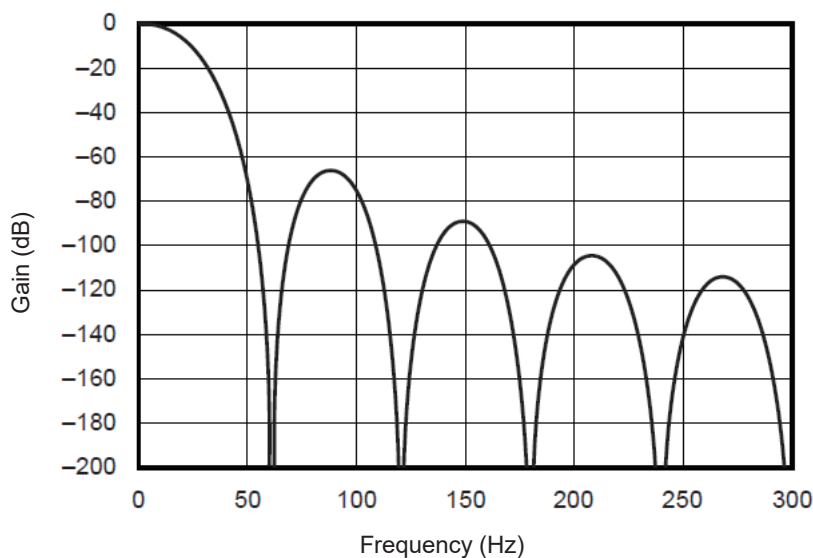

# 14.3 Noise Countermeasures

This section describes countermeasures in a noise environment.

## Mechanism of noise mixing

### Noise source

In factories, a large current at 50 Hz/60 Hz is passed as the power source. The main loads include many inductive loads, such as motors and solenoids. For inverters and high frequency induction furnace, etc., a large amount of pulse current is passed in capacitor input type switching power supplies. Leakage current of the fundamental wave component, harmonic current, etc. are passed from the respective earths into the earth line including the ground.

### Noise transmission path

- Leakage route to the input signal when the common mode voltage is activated between the grounds of the measurement target and the measuring Instrument
- Route in which the AC magnetic field is coupled with the loop section of the input signal line by the power supply line current
- Route in which capacitance between the input signal line and the power supply line is coupled

### Common mode noise

Noise occurring between the input +/- terminals on the measuring Instrument and the ground

### Normal mode noise

Noise between lines occurring between the input +/- terminals on the measuring Instrument

### Example of connection susceptible to noise

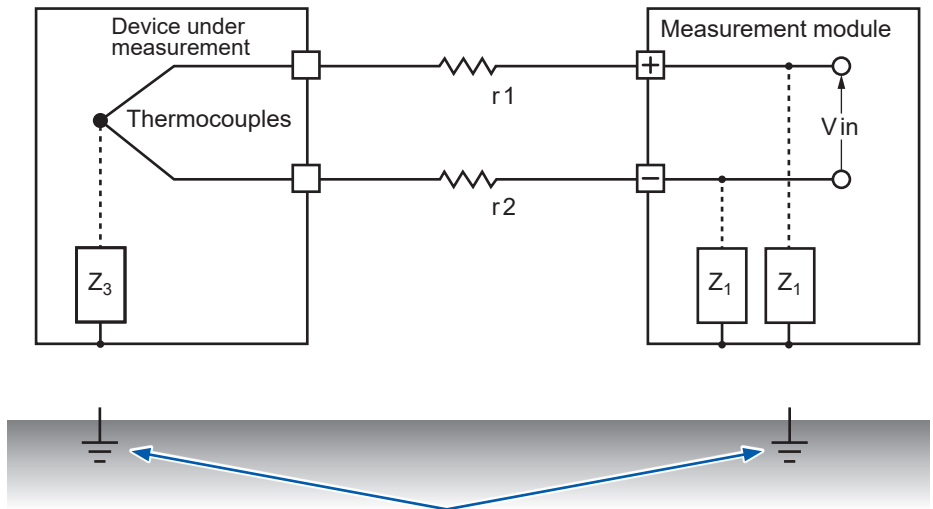

Temperature measurement using a thermocouple is affected by noise unless both the instrument to be measured and the measurement module are connected to the ground. Be sure to ground the AC adapter when using it.

### Equivalent circuit of noise transmission path

The following noise can directly affect the measured value as the normal mode voltage.  
 Electromagnetic induction noise due to the coupling of the AC magnetic field generated from inverters and commercial power supplies with the loop of input line of the measurement instrument.  
 Electrostatic induction noise due to the capacitive coupling between the wirings.

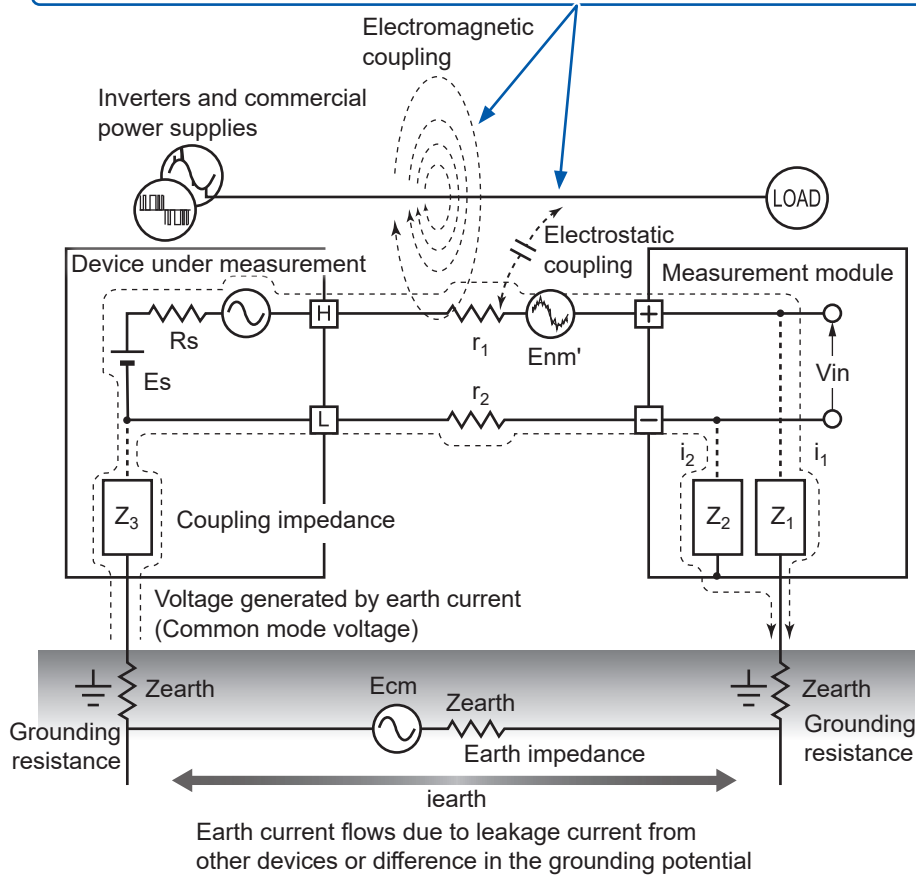

Common mode noise occurs when the earth impedance intervenes between the grounding point of the device under measurement and the grounding point of the measurement module, or if the earth line is coupled capacitively with a noise source.

The common mode noise is converted to normal mode voltage ( $E_{nm}$ ) applied across each +/- input terminals of the measuring instrument, when the noise currents ( $i_1, i_2$ ) are passed through the coupling impedances ( $Z_1, Z_2$ ) between the +/- input terminals of the measurement module and the ground. Since this voltage occurs between the input terminals, the measured value is directly affected.

## Examples of noise countermeasures

### Ground securely

- Ground the instrument securely  
The chassis GND can be grounded by connecting the 2-pole grounding power cord of the AC adapter to an outlet with the grounding electrode.
- Ground the chassis GND of the measurement target securely  
Ground the chassis GND of the measurement target to a good earth securely

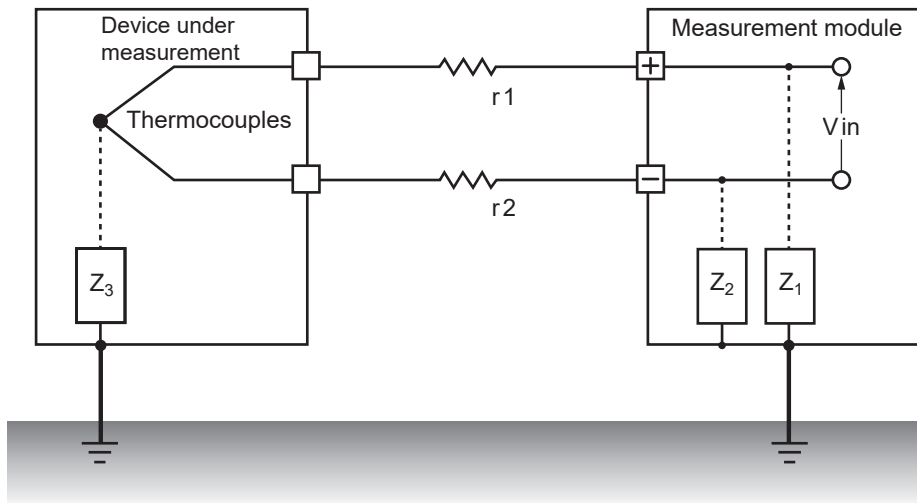

## Countermeasures against common mode noise

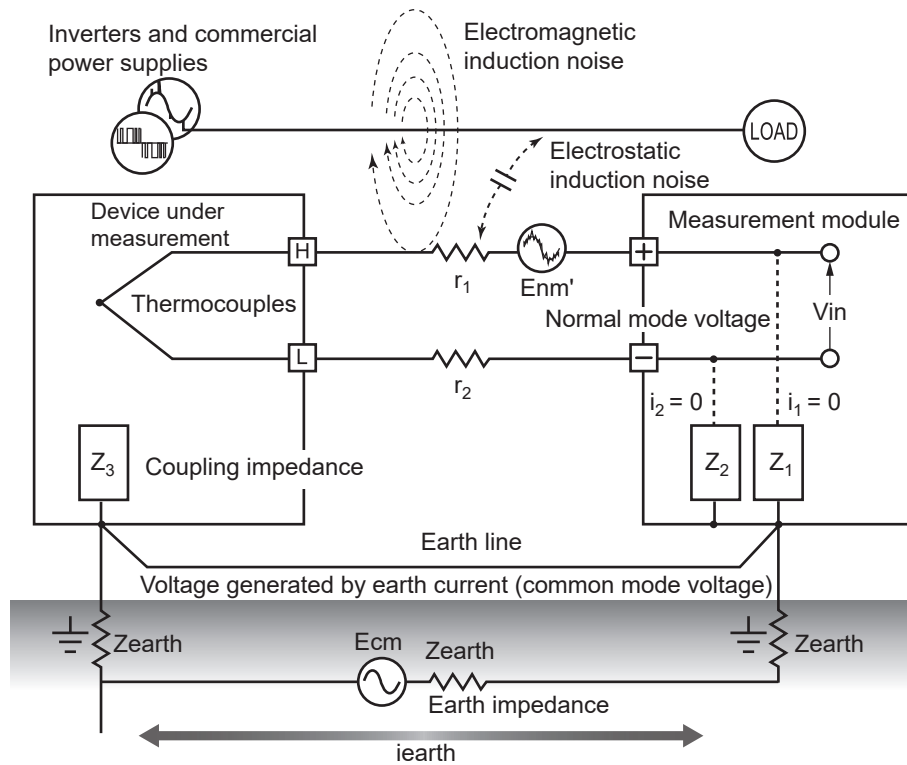

Ground the chassis GND on the signal side to a good earth with a sufficiently low grounding resistance.

Connect to an earth line with a low resistance or bypass between the grounding electrodes. This can reduce the common mode voltage, decreasing the noise currents ( $i_1$ ,  $i_2$ ). As a result, the generation of normal mode voltage can be suppressed, reducing the effect on the measured value.

### Block external noise

- Keep signal lines away from noise sources  
Keep the input signal lines (thermocouples) away from the wiring that can be noise sources (power lines, etc.).  
Alternatively, separate the signal lines and the wiring as far as possible, for example, by installing them in separate ducts.
- Use shielded and twisted pair wires.  
Shielded and twisted pair wires are effective for the input signal lines (thermocouples).  
The twisted pair wires are effective for preventing electromagnetic induction, while the shielded wires are effective for preventing electrostatic induction.  
Ground the shielded wire on the signal source side.  
For thermocouples with shielded and twisted pair wires, contact the manufacturers of thermocouples.

## Countermeasures against normal mode noise

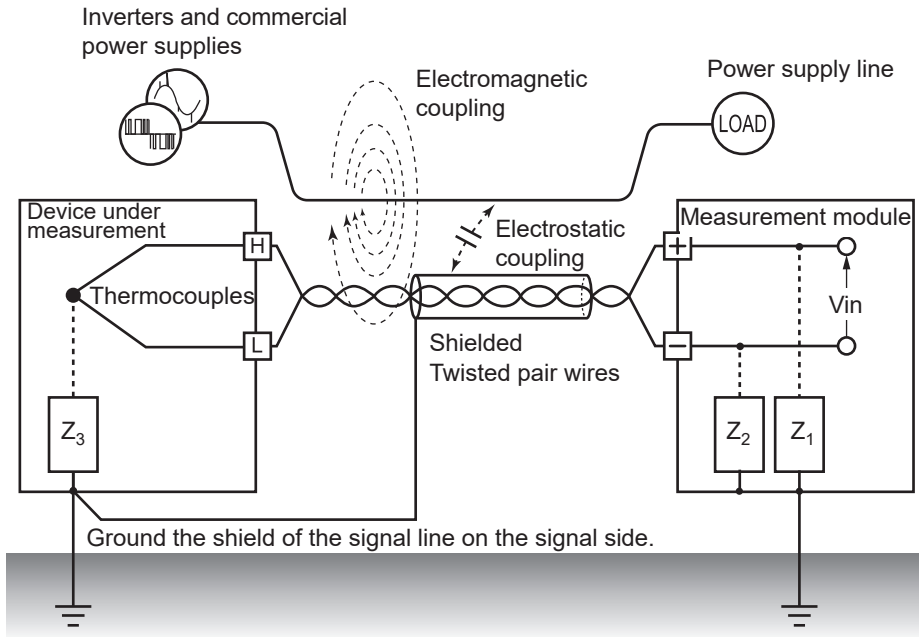

Keep away and separate the signal lines (thermocouples) from the wiring that can be noise sources (power lines, etc.). Furthermore, electrostatic coupling can be blocked by shielding and grounding the signal lines.

- Isolation from noise sources (temperature measurement using a thermocouple)  
Isolation is achieved between the input channels and housing as well as between the input channels. Measurement can be performed using a thermocouple directly attached to a conductor with a potential up to maximum rated line-to-ground voltage.  
If the measurement is affected by noise, it is effective to isolate the thermocouple by wrapping it with high temperature resistant tape, or use a non-grounding thermocouple and isolate the input lines.
- Use a filter  
Noise mixed with the input signals can be removed with a power-supply frequency filter.  
It is recommended to set the value to the same frequency as the power-supply frequency of the region where the instrument is used (50 Hz or 60 Hz).  
See "10.1 Setting the Environment" (p. 225).



## Insert a capacitor into the signal line

For noise from overlapped signal sources and high frequency pulses, it is effective to insert a capacitor between the input +/- terminals. This capacitor can prevent the noise from entering inside the instrument.

Use a capacitor with a rated voltage higher than the voltage to be input.

Since the filter is applied before the channel scan, there is no limitation of the data refresh interval.

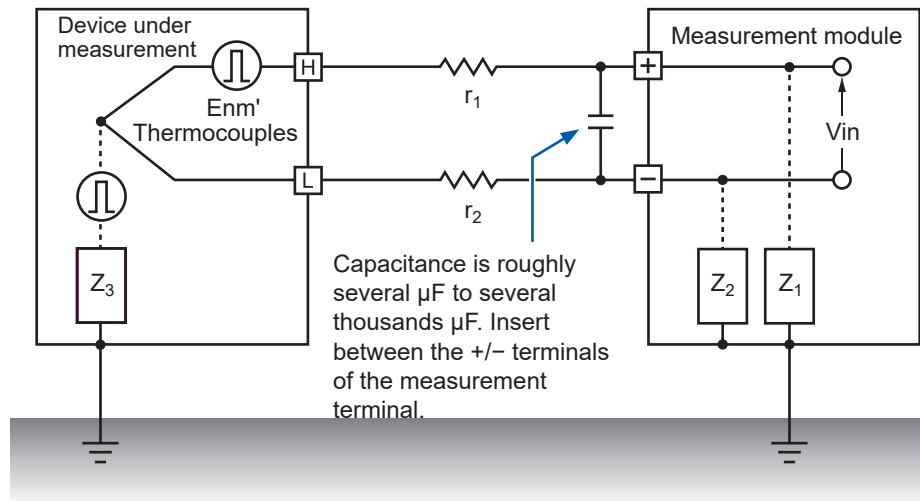

## 14.4 Timing of Scan

The following modules perform scans by switching the input channels with relays to acquire data.

- M7100 Voltage/Temp Module
- M7102 Voltage/Temp Module

All input channels are scanned within the specified time of the data refresh interval.

The measurement ON channels are scanned sequentially starting from CH1 as CH1→CH2→CH3 and so on. The sampling is performed again starting from CH1 at the next data refresh interval.

The scan time width necessary for 1 channel depends on the type of measurement module, number of channels being used, data refresh interval, power-supply frequency filter, and wire break detection setting.

## For M7100

The figures below show typical examples of scan timing in M7100.

### Example: Data refresh interval 10 ms, measurement ON in all 15 channels, wire break detection OFF

CH1 to CH 15 are scanned with the time width of approx. 0.5 ms per channel.

The scan is performed again starting from CH1 after 10 ms (data refresh interval) has elapsed.

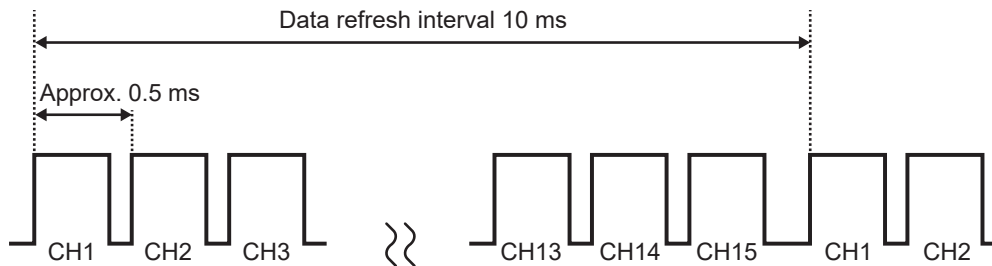

### Example: Data refresh interval 10 ms, measurement ON in CH1, CH5, and CH15, wire break detection OFF

Only the measurement ON channels are scanned without scanning the measurement OFF channels.

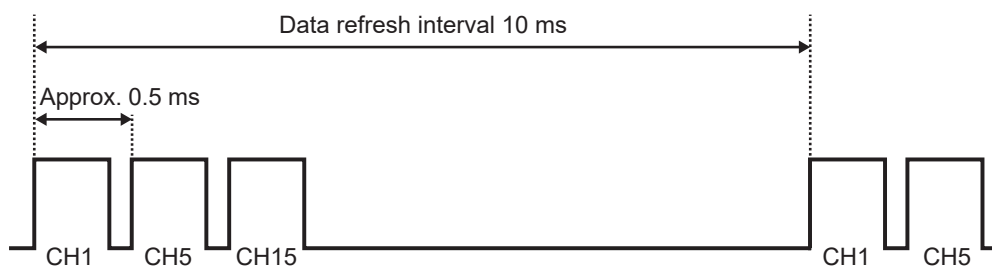

### Example: Data refresh interval 5 s, measurement ON in all 15 channels, wire break detection OFF

Depending on the setting of the power-supply frequency filter, CH1 to CH15 are scanned with the time width of approx. 160 ms or approx. 180 ms.

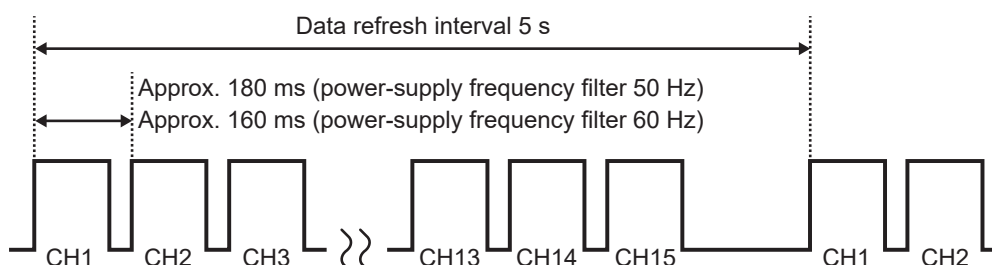

## For M7102

The figures below show typical examples of scan timing in M7200 when the number of channels being used is 16 to 30. When the number of channels being used is 15 or less, the scan timing is the same as M7100.

### Example: Data refresh interval 20 ms, measurement ON in all 30 channels, wire break detection OFF

CH1 to CH 30 are scanned with the time width of approx. 0.5 ms per channel.

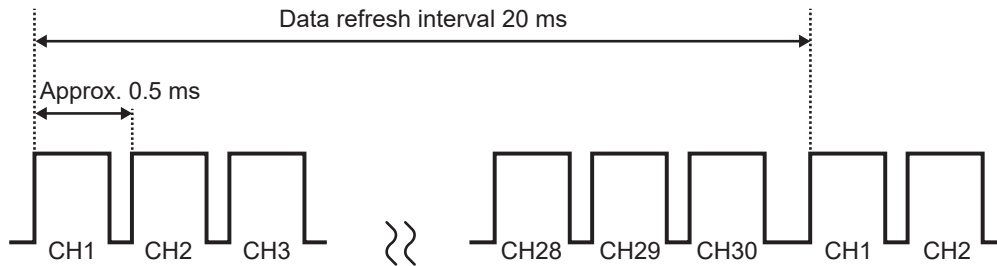

### Example: Data refresh interval 20 ms, measurement ON in CH1 to CH10 and CH21 to CH30, wire break detection OFF

Only the measurement ON channels are scanned without scanning the measurement OFF channels.

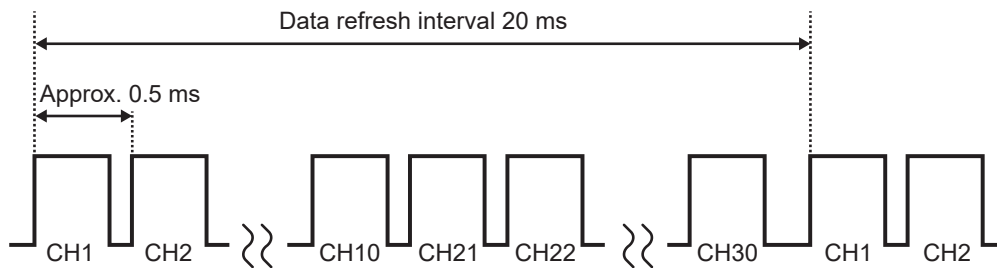

### Example: Data refresh interval 5 s, measurement ON in all 30 channels, wire break detection OFF

Depending on the setting of the power-supply frequency filter, CH1 to CH30 are scanned with the time width of approx. 90 ms or approx. 105 ms.

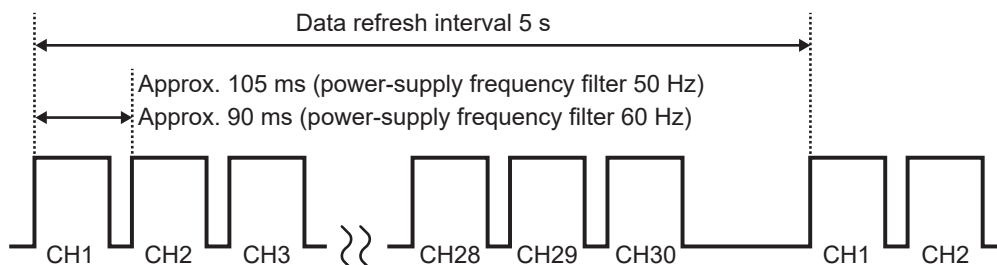

## 14.5 File Name

The file name is organized as follows.

### WAVE0001.MEM

1    2    3

| No. | Item             |
|-----|------------------|
| 1   | File type        |
| 2   | Automatic number |
| 3   | Extension        |

| Data name                                    | Folder               | File type                                  | Automatic number           | Extension                           |
|--|----------------------|--|----------------------------|-------------------------------------|
| Setting condition                            | CONFIG               | CONF                                       | 0001 or more               | .SET                                |
| Waveform data                                | DATA * <sup>1</sup>  | WAVE * <sup>2</sup><br>AUTO * <sup>3</sup> | 0001 or more               | .MEM<br>.CSV * <sup>4</sup><br>.MF4 |
| Numerical calculation results<br>Not divided | MEASUREMENT<br>/ALL  | MEAS * <sup>2</sup><br>AUTO * <sup>3</sup> | 0001 or more* <sup>5</sup> | .CSV * <sup>4</sup>                 |
| Numerical calculation results<br>Divided     | MEASUREMENT<br>/PART | MEAS * <sup>2</sup><br>AUTO * <sup>3</sup> | 0001 or more* <sup>5</sup> | .CSV * <sup>4</sup>                 |
| A2L  | A2L                  | XCPT<br>XCPU                               | 0001 or more               | .A2L                                |

- \*1. The date folders are automatically created. The deleting operation deletes the older waveform file first. If all waveform files in the date folder are deleted, the folder name is automatically updated.  
Example: Before update 23-03-26 → After update 23\_03\_26\_230330\_101113 (Date\_Update date\_time)  
Hyphens (-) are replaced with underscores (\_), and the date and time when the folder name is changed are placed at the end.  
(Changed at 2023-3-30 10:11:13)
- \*2. When the file is saved manually.
- \*3. When the file is saved automatically. When a file name is specified, the specified name is used.
- \*4. If the delimiter is set to other than **[COMMA]**, the extension is **[.TXT]**.
- \*5. If the file splitting for numerical calculation result is ON, an underscore (\_) and the calculation number is attached to the numbers starting from 0001.

## 14.6 File Configuration for Text Format

A file in the text format is composed of the header part and the data part.  
The header part contains the following information.

- (1) **File: Name and version number**
- (2) **Title comment**
- (3) **Trigger time**
- (4) **Channel number for each column\*<sup>1</sup>**
- (5) **Contents of measurement\*<sup>2</sup>**
- (6) **Range**
- (7) **Module identification name**
- (8) **Comment**
- (9) **Scaling setting**
- (10) **Conversion ratio for scaling**
- (11) **Offset for scaling**
- (12) **Channel number\*<sup>1</sup> and unit for each row**
- (13) **Data\*<sup>3</sup>**

```
"File name","AUTO0001.CSV","V 1.00" ..... (1)
"Title comment" ..... (2)
"Trigger Time","23-03-26 10:15:32" ..... (3)
"CH","CH1-1","ALM1","ALM2","W1","Event", ..... (4)
"Mode","Voltage","Alarm","Alarm","Calculation", ..... (5)
"Range","1V","","", ..... (6)
"ModuleID","","", ..... (7)
"Comment","","", ..... (8)
"Scaling","OFF", ..... (9)
"Ratio","+1.00000E+00", ..... (10)
"Offset","+0.00000E+00", ..... (11)
"Time","CH1-1[V]","ALM1","ALM2","W1[]",
"Event", ..... (12)
+0.000000000E+00,-3.325000000E-02,0,0,-6.650000000E-02,0, ..... (13)
+1.000000000E-01,+2.850000000E-02,1,0,+5.700000000E-02,0,
+2.000000000E-01,+9.600000000E-03,0,0,+1.920000000E-02,0,
+3.000000000E-01,-2.560000000E-02,0,0,-5.120000000E-02,0,
+4.000000000E-01,+4.560000000E-02,1,1,+9.120000000E-02,0,
```

\*1. The channel numbers are output based on the data types as follows.

Analog direct connection (CHx-xx), pulse (Py), logic (Ly), alarm (ALMz), waveform calculation (Wxx)

(xa: 1 to 10, xx: 1 to 30, y: 1, z: 1 to 4)

If the statistical value is selected for saving data, the columns for average (ave), maximum (max), and minimum (min) are added to each item.

\*2.The following are output according to the measurement target.

Voltage (Voltage), thermocouple (Tc), aggregation (Count), rotation speed (Revolve), logic (Logic), alarm (Alarm), waveform calculation (Calculation)

\*3.The following are output according to the types of measurement data.

| Data type                           | Output type                                   |
|-------------------------------------|---|
| Analog, Pulse, waveform calculation | Exponential notation (10 significant figures) |
| Logic                               | 0: Low, 1: High                               |
| Alarm                               | 0: Not issued, 1: Issued                      |
| Event mark                          | 0: No mark, 1: Place marks                    |

## 14.7 File Size

The calculation formula for the size of the binary waveform file (MEM) is described below.  
Unit: byte

### File size

Header size + data size

### Header size

Shared header size + text header size + binary header size

### Shared header size

$1000 + \text{Number of channels on the measurement module} \times 680 + \text{Number of pulse channels} \times 650 + \text{Number of logic channels} \times 240 + \text{Number of waveform calculation channels} \times 450 + \text{Number of alarm channels} \times 256$

(This value is given only as a guide, because it can vary depending on the settings)

### Text header size

$512 \times (10 + \text{Number of channels on the measurement module} \times 4 + \text{Number of pulse channels} \times 4 + \text{Number of logic channels} \times 3 + \text{Number of waveform calculation channels} \times 6 + \text{Number of alarm headers}^{*1})$

\*1. When the alarm is ON, then 8.  
When the alarm is OFF, then 0.

### Binary header size

$512 \times (17)$

### Data size

$(\text{Number of channels on the measurement module} \times 4 + \text{Number of pulse channels} \times 4 + \text{Number of waveform calculation channels} \times 8 + \text{logic data size}^{*2} + \text{alarm data size}^{*3}) \times \text{Number of data points}$

\*2. If any one of the logic is ON, then 2. If no logic is ON, then 0.

\*3. When the alarm is ON, then 2.  
When the alarm is OFF, then 0.



## 14.8 Settings After Initialization (System Reset)

At the time of shipping and after the instrument is initialized (system reset), the following settings are applied (for M7100).

See “Initialization” (p. 234).

| Category            |           | Settings                             |                              |  |     |  |
|---------------------|-----------|--------------------------------------|------------------------------|--|-----|--|
| Main                | Sub       | Parameter                            | Default setting              |  |     |  |
| Measurement         | Recording | Measurement start                    | Manual                       |  |     |  |
|                     |           | Measurement stop                     | Manual                       |  |     |  |
|                     |           | REC mode                             | Normal                       |  |     |  |
|                     |           | Recording interval                   | 10 ms                        |  |     |  |
|                     |           | Repetitive recording                 | OFF                          |  |     |  |
|                     |           | Recording time                       | Continuous recording         |  |     |  |
|                     |           | Synchronous operation                | OFF                          |  |     |  |
|                     | Auto save | File name to be saved                |                              | –  |     |  |
|                     |           |                                      | Add title comment            | OFF  |     |  |
|                     |           |                                      | Add trigger date/time        | OFF  |     |  |
|                     |           | Media (preferred saving destination) | SD memory card               |  |     |  |
|                     |           | Waveform data                        | Format                       | OFF  |     |  |
|                     |           |                                      | Downsampling                 | OFF  |     |  |
|                     |           |                                      | Deleting                     | OFF  |     |  |
|                     |           |                                      | Folder splitting             | Division disabled                          |     |  |
|                     |           |                                      | File splitting               | Division disabled                          |     |  |
|                     |           | Numerical calculation results        | Format                       | OFF  |     |  |
|                     |           |                                      | File splitting               | Single file (all calculations in one file) |     |  |
|                     |           | Text format                          | Decimal symbol* <sup>1</sup> | Period                                     |     |  |
|                     |           |                                      | Delimiter* <sup>1</sup>      | Comma                                      |     |  |
|                     |           |                                      | Date format                  | yy-MM-dd hh:mm:ss.0                        |     |  |
|                     |           | Manual save                          | File name to be saved        | –  |     |  |
|                     |           |                                      |                              | Add trigger date/time                      | OFF |  |
|                     |           |                                      | Downsampling                 | OFF  |     |  |
|                     | Display   | Display horizontal axis              | Time                         |  |     |  |
|                     | Settings  | Auto setup* <sup>1</sup>             | OFF                          |  |     |  |
|                     | Channel   | Individual                           | Channel                      | Measurement                                | ON  |  |
| Input               |           |                                      | Input type                   | Voltage                                    |     |  |
|                     |           |                                      | Range                        | 10 mV                                      |     |  |
| Scaling             |           |                                      | OFF                          |  |     |  |
| Comment             |           |                                      | –                            |  |     |  |
| Numerical threshold | 0         |                                      |                              |  |     |  |

\*1. Excluded from initialization (factory setting).

Settings After Initialization (System Reset)

| Category        |                       | Settings                      |                 |                     |
|-----------------|-----------------------|-------------------------------|-----------------|---------------------|
| Main            | Sub                   | Parameter                     | Default setting |                     |
| Trigger         | Common                | Trigger                       | OFF             |                     |
|                 |                       | Trigger timing                | Start           |                     |
|                 |                       | Pre-trigger                   | Time            | 0 days and 00:00:00 |
|                 |                       | Trigger condition             | Start           | OR                  |
|                 |                       | External trigger              | OFF             |                     |
|                 |                       | Interval trigger              | OFF             |                     |
|                 |                       | Trigger type                  | Start           | OFF                 |
|                 |                       | Stop                          | OFF             |                     |
| Alarm           | Common                | Alarm                         | OFF             |                     |
|                 |                       | Alarm hold                    | OFF             |                     |
|                 |                       | Alarm buzzer                  | OFF             |                     |
|                 |                       | Event mark                    | OFF             |                     |
|                 |                       | Alarm history                 | First 100       |                     |
|                 | Alarm 1-4             | ALM1 to ALM4                  | Filter          | OFF                 |
|                 |                       | Comment                       | –               |                     |
| Calculation     | Numerical calculation | Numerical calculation         | OFF             |                     |
|                 | Waveform calculation  | Waveform calculation          | OFF             |                     |
| System          | Environment           | Start backup                  | OFF             |                     |
|                 |                       | Language* <sup>1</sup>        | English         |                     |
|                 |                       | Beep sound                    | ON              |                     |
|                 |                       | Power-supply frequency filter | 60 Hz           |                     |
|                 | External terminal     | Alarm output 1 to 4           | Low             |                     |
|                 |                       | External input 1 to 3         | OFF             |                     |
| External output |                       | OFF                           |                 |                     |

\*1. Excluded from initialization (factory setting).

## 14.9 Maxi Recording Time

This section describes how to calculate the maximum time that can be recorded on the internal buffer memory or media on the instrument.

When data are saved in the binary format, the maximum recording time can be calculated with the following equation.

$$\text{Maximum recording time} = \text{Storage capacity}^{*1} \times \text{Recording interval (sec)} / \text{Data size}^{*2}$$

\*1. For the internal buffer memory of the instrument (512 MB),  $512 \times 1024 \times 1024$

\*2. Data size in "11.9 File Size" (p.383)

### Maximum recording time (rough estimation)

Example: Measurement of 30 analog channels across 2 modules (no alarm output, no waveform calculations).

Since the size of the header part of the waveform file is not included, use approx. 90% of the values in the table below as a guide. The less the number of channels being recorded, the longer the maximum recording time.

| Recording interval | Internal buffer memory (512 MB) | Z4001 (2 GB)          |
|--------------------|---------------------------------|-----------------------|
| 100 ms             | 5 days and 4 hours              | 19 days and 9 hours   |
| 200 ms             | 10 days and 8 hours             | 38 days and 18 hours  |
| 500 ms             | 25 days and 21 hours            | 96 days and 21 hours  |
| 1 s                | 51 days and 18 hours            | 193 days and 19 hours |
| 5 s                | 258 day                         | 581 days and 10 hours |
| 10 s               | 500 day                         | 1938 days and 4 hours |

## 14.10 Applied Measurement

### Recording of instrumentation signal (4-20 mA)

This section introduces a method for recording a current output (4-20 mA) from the instrumentation device.

Average every 1 minute is also recorded using the numerical calculation.

- Applicable modules: M7100, M7102
- Required item: Input cable, 250  $\Omega$  shunt resistor

#### Operation method

**1** Connect the input cable and 250  $\Omega$  shunt resistor to the channel to be measured.

Connect the shunt resistor between the input +/- terminals.

See "Wiring the voltage cable and thermocouple" (p. 44).

**2** Connect the input cable to the current output (4-20 mA) terminal on the instrumentation device.

**3** Set the data refresh interval to auto.

See "Data refresh interval of the measurement modules" (p. 90).

**4** Configure the settings as follows.

|                    |  |
|--------------------|--|
| Recording interval | 5 s  |
| Recording time     | Time specification, 1 hour (0 days and 01:00:00) |

See "3.3 Setting Measurement Conditions" (p. 82).

**5** Configure the settings as follows.

|  |                     |
|--|---------------------|
| Media (Preferred saving destination)   | SD memory card      |
| Format (waveform data)                 | Binary format (MEM) |
| Format (numerical calculation results) | Text format (CSV)   |

See "Auto save (Realtime save)" (p. 164).

**6** Configure the settings as follows.

|                        |                             |
|------------------------|-----------------------------|
| Numerical calculation  | ON                          |
| Time split calculation | Division enabled            |
| Split time             | 1 minute (0 days and 00:01) |
| Operation type         | Average                     |

See "Setting the numerical calculations" (p. 210).

## 7 Configure the settings as follows. (p.94)

|            |         |
|------------|---------|
| Input type | Voltage |
| Range      | 1-5 V   |

Since the 250 $\Omega$  resistor is connected to the input terminal, 4 mA and 20 mA are recorded as 1 V and 5 V, respectively.

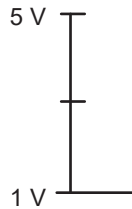

## 8 Execute the **START** command to start measurement.

Data are recorded for 1 hour at intervals of 5 seconds.

In addition, the average is calculated every 1 minute using the numerical calculation and saved to the SD memory card.

The recording is stopped 1 hour after the recording is started.

To stop the recording halfway, execute the **STOP** command.

See “3.9 Starting and Stopping Measurement” (p. 118).

## Measurement of power consumption using pulse output of watt-hour meter

This section describes a method for measuring pulses of watt-hour meter and converting them to the power consumption.

Measure the pulse output of watt-hour meter (50,000 pulses/kWh) and record the power consumption per 30 minutes and the power consumption per 1 month (30 days) to an SD memory card.

- Required item: Input cable

### Operation method

**1** Connect the pulse output of the watt-hour meter to the pulse input terminal (PULSE) on the instrument.

**2** Configure the settings as follows.

|                    |  |
|--------------------|--|
| Recording interval | 30 min   |
| Recording time     | Time specification, 30 days (30 days and 00:00:00) |

**3** Configure the settings as follows.

|                                      |                     |
|--------------------------------------|---------------------|
| Media (Preferred saving destination) | SD memory card      |
| Format                               | Binary format (MEM) |

**4** Set as follows.

|                 |  |
|-----------------|--|
| Input type      | Count  |
| Count mode      | Addition   |
| Slope           | ↑ (according to the specifications of the watt-hour meter)   |
| Threshold value | 1 V (according to the specifications of the watt-hour meter) |
| Filter          | ON *1  |
| Scaling         | Decimal fraction, 1 kWh = 5000 (5 k), Unit: kWh              |

\*1. A count error due to chattering can be prevented.

With the scaling function, the number of pulses can be converted to the electric energy (kWh).

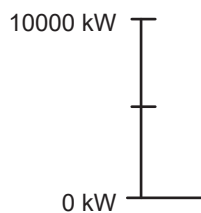

**5** Execute the **START** command to start measurement.

Data are recorded for 30 days at intervals of 30 minutes and waveform data is saved to an SD memory card.

The recording is stopped 30 days after the recording is started.

To stop the recording halfway, execute the **STOP** command.

# 14.11 Configuration of Input Circuit

This section shows the configuration of the input circuit of the instrument.

## Analog input circuit

- Voltage (10 mV f.s. to 6 V f.s. range), thermocouple

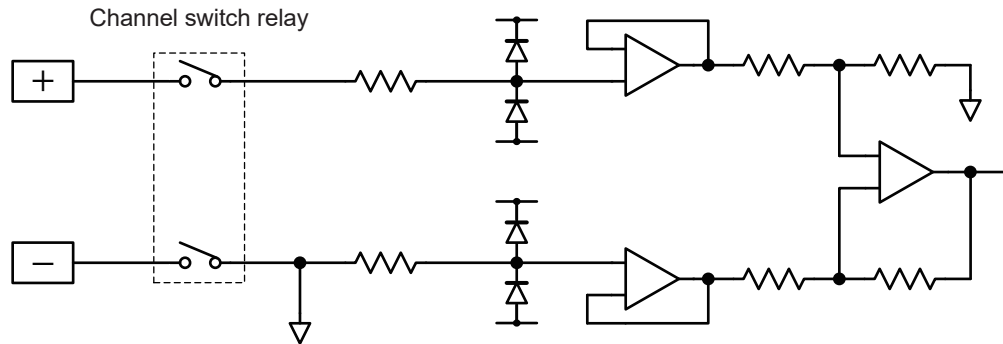

- Voltage (10 V f.s. to 100 V f.s., 1-5 V f.s. range)

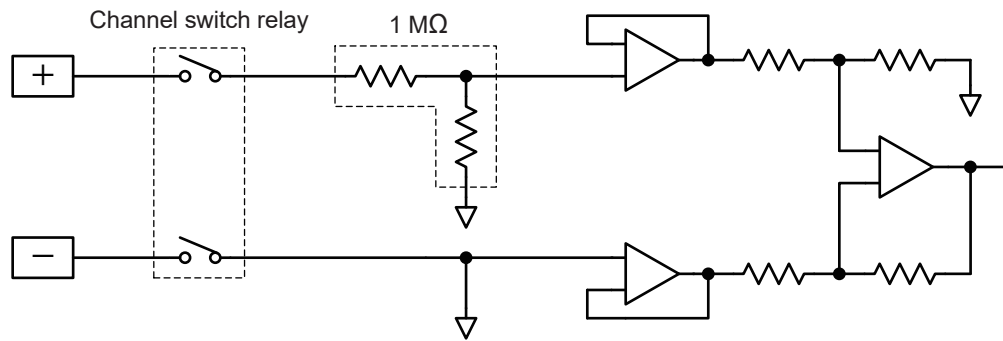

## Pulse input circuit

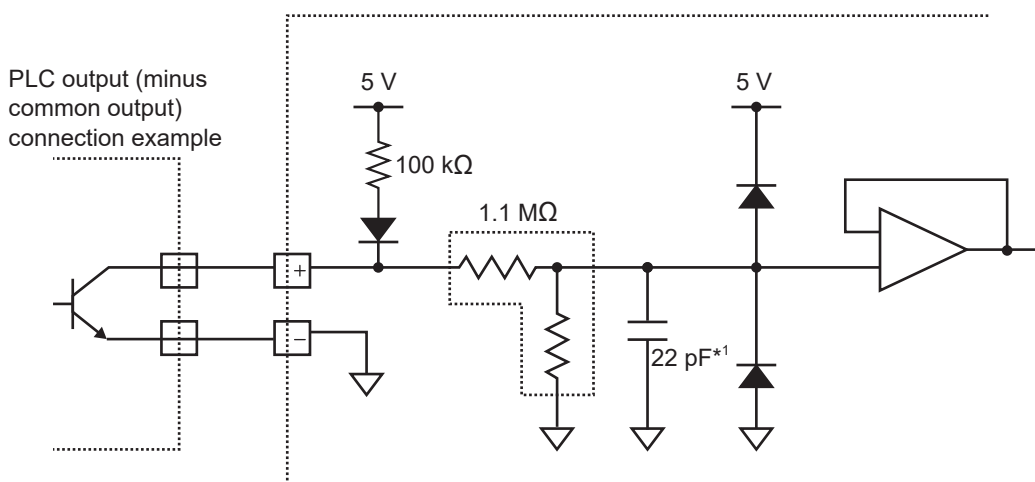

\*1. 0.047 μF when the chattering prevention filter is ON.

## 14.12 Data Handling

In the following cases, the values in the table below are used as the measured value and the calculated value.

- When the waveform significantly exceeds the allowable measurement range of each range (+OVER, -OVER)
- When a thermocouple wire break is detected during temperature measurement (wire break detection)
- When no data exists (NO DATA)

### Measurement data special values

#### Communication commands and save data for acquiring a measured value in text (physical value)

See “4 Acquiring Measurement Data” (p. 123).

| Input type                             | +OVER        | -OVER        | Burnout detection | NO DATA      |
|--|--------------|--------------|-------------------|--------------|
| Measurement channel for plug-in module | +7.77777E+99 | -7.77777E+99 | +8.88888E+99      | +9.99999E+99 |
| Pulse (count/rotation speed)           | +7.77777E+99 | –            | –                 | +9.99999E+99 |
| Waveform calculation                   | –            | –            | –                 | +9.99999E+99 |

#### Communication commands for acquiring a measured value in text (AD value)

See “4 Acquiring Measurement Data” (p. 123).

| Input type                             | +OVER      | -OVER       | Burnout detection | NO DATA      |
|--|------------|-------------|-------------------|--------------|
| Measurement channel for plug-in module | 2147483647 | -2147483648 | 2147483646        | 2147483645   |
| Pulse (count/rotation speed)           | 2147483647 | –           | –                 | 2147483645   |
| Waveform calculation                   | –          | –           | –                 | +9.99999E+99 |

#### Communication commands for acquiring a measured value in binary

See “4 Acquiring Measurement Data” (p. 123).

| Input type                             | +OVER      | -OVER      | Burnout detection | NO DATA            |
|--|------------|------------|-------------------|--------------------|
| Measurement channel for plug-in module | 0x7FFFFFFF | 0x80000000 | 0x7FFFFFFE        | 0x7FFFFFFD         |
| Pulse (count/rotation speed)           | 0x7FFFFFFF | –          | –                 | 0x7FFFFFFD         |
| Waveform calculation                   | –          | –          | –                 | 0x7ff0000000000001 |



## Calculation special values

Calculation is performed based on the values in the following table.

| Input type           | Input range  | +OVER         | -OVER         | Burnout detection | NO DATA                     |
|----------------------|--------------|---------------|---------------|-------------------|-----------------------------|
| Voltage              | 10 mV        | 214.7483647   | -214.7483648  | -                 | 214.7483645                 |
|                      | 20 mV        | 429.4967294   | -429.4967296  | -                 | 429.496729                  |
|                      | 100 mV       | 2147.483647   | -2147.483648  | -                 | 2147.483645                 |
|                      | 200 mV       | 4294.967294   | -4294.967296  | -                 | 4294.96729                  |
|                      | 1 V          | 21474.83647   | -21474.83648  | -                 | 21474.83645                 |
|                      | 2 V          | 42949.67294   | -42949.67296  | -                 | 42949.6729                  |
|                      | 6 V          | 128849.01882  | -128849.01888 | -                 | 128849.0187                 |
|                      | 10 V         | 214748.3647   | -214748.3648  | -                 | 214748.3645                 |
|                      | 20 V         | 429496.7294   | -429496.7296  | -                 | 429496.729                  |
|                      | 60 V         | 1288490.1882  | -1288490.1888 | -                 | 1288490.187                 |
|                      | 100 V        | 2147483.647   | -2147483.648  | -                 | 2147483.645                 |
| 1-5 V                | 128849.01882 | -128849.01888 | -             | 128849.0187       |                             |
| Thermocouples        | 100°C        | 21474836.47   | -21474836.48  | 21474836.46       | 21474836.45                 |
|                      | 500°C        | 107374182.35  | -107374182.4  | 107374182.3       | 107374182.25                |
|                      | 2000°C       | 214748364.7   | -214748364.8  | 214748364.6       | 214748364.5                 |
| Count                | 1000 Mc      | 2147483647    | -             | -                 | 2147483645                  |
| Rotation speed       | 5000 r/s     | 2147483647    | -             | -                 | 2147483645                  |
|                      | 300000 r/min | 2147483647    | -             | -                 | 2147483645                  |
| Waveform calculation | -            | -             | -             | -                 | 1.797693134<br>8623157e+308 |

## Special value for measured value output using LAN2

See “12.8 Outputting the Measured Value Using LAN2” (p. 285).

When the data format of the measured value to be output is INT32 (when endian is set to BIG)

| Input type                             | +OVER      | -OVER      | Burnout detection |
|--|------------|------------|-------------------|
| Measurement channel for plug-in module | 0x7FFFFFFF | 0x80000000 | 0x7FFFFFFE        |
| Pulse (count/rotation speed)           | 0x7FFFFFFF | –          | –                 |
| Waveform calculation                   | –          | –          | –                 |

When the data format of the measured value to be output is FLOAT or INDEX

- When the data format is FLOAT, binary data is output. The values in the following table can be obtained by converting the binary data.
- When the data format is INDEX, ASCII code data is output. The values in the following table can be obtained by converting the ASCII code.

| Input type           | Input range  | +OVER        | -OVER         | Burnout detection |
|----------------------|--------------|--------------|---------------|-------------------|
| Voltage              | 10 mV        | 214.7483647  | -214.7483648  | –                 |
|                      | 20 mV        | 429.4967294  | -429.4967296  | –                 |
|                      | 100 mV       | 2147.483647  | -2147.483648  | –                 |
|                      | 200 mV       | 4294.967294  | -4294.967296  | –                 |
|                      | 1 V          | 21474.83647  | -21474.83648  | –                 |
|                      | 2 V          | 42949.67294  | -42949.67296  | –                 |
|                      | 6 V          | 128849.01882 | -128849.01888 | –                 |
|                      | 10 V         | 214748.3647  | -214748.3648  | –                 |
|                      | 20 V         | 429496.7294  | -429496.7296  | –                 |
|                      | 60 V         | 1288490.1882 | -1288490.1888 | –                 |
|                      | 100 V        | 2147483.647  | -2147483.648  | –                 |
| Thermocouple         | 100°C        | 21474836.47  | -21474836.48  | 21474836.46       |
|                      | 500°C        | 107374182.35 | -107374182.4  | 107374182.3       |
|                      | 2000°C       | 214748364.7  | -214748364.8  | 214748364.6       |
| Count                | 1000 Mc      | 2147483647   | –             | –                 |
| Rotation speed       | 5000 r/s     | 2147483647   | –             | –                 |
|                      | 300000 r/min | 2147483647   | –             | –                 |
| Waveform calculation | –            | –            | –             | –                 |

## Special value for measured value output using CAN

See “12.6 Outputting the Measured Value Using CAN” (p. 280).

| Input type                             | +OVER      | -OVER      | Burnout detection | NO DATA            |
|--|------------|------------|-------------------|--------------------|
| Measurement channel for plug-in module | 0x7FFFFFFF | 0x80000000 | 0x7FFFFFFE        | 0x7FFFFFFD         |
| Pulse (count/rotation speed)           | 0x7FFFFFFF | –          | –                 | 0x7FFFFFFD         |
| Waveform calculation                   | –          | –          | –                 | 0x7ff0000000000001 |

The value converted using the settings of the DBC file is the same as the special value for calculation.

## 14.13 Module-related Commands

If both the header and data parts of a command are related to modules, the specification with UNIT can be accepted.

```
:MODule:DATARate module$,A
:MODule:DATARate? module$
```

In this case

|          |                             |
|----------|-----------------------------|
| :MODule  | Can be replaced with :UNIT  |
| module\$ | Can be replaced with unit\$ |



If the header is ON, the header part is fixed to MODULE in the returned response.

### Command example

| Settings                       |  |                             |
|--------------------------------|--|-----------------------------|
| Syntax                         | Command  | :MODule:DATARate module\$,A |
| Example                        | :MODule:DATARate MODULE1,1.0E+00   |                             |
| Query                          |  |                             |
| Syntax                         | Query  | :MODule:DATARate? module\$  |
|                                | Response   | A                           |
| Example                        | :MODule:DATARate? MODULE1<br>(Response) :MODULE:DATARATE MODULE1,1.0E+00 (When the header is ON) |                             |
| Parameter                      |  |                             |
| module\$ = MODULE1 to MODULE10 |  |                             |

For the command above, the next command results in the same operation.

| Settings                 |  |                         |
|--------------------------|--|-------------------------|
| Syntax                   | Command  | :UNIT:DATARate unit\$,A |
| Example                  | :UNIT:DATARate UNIT1,1.0E+00   |                         |
| Query                    |  |                         |
| Syntax                   | Query  | :UNIT:DATARate? unit\$  |
|                          | Response   | A                       |
| Example                  | :UNIT:DATARate? UNIT1<br>(Response) :MODULE:DATARATE MODULE1,1.0E+00 (When the header is ON) |                         |
| Parameter                |  |                         |
| unit\$ = UNIT1 to UNIT10 |  |                         |

# 14.14 The Measured Data Realtime Output

During realtime output, data are designed to be output every time the measurement data number increases. However, if the measurement data number increases by more than one due to the modules having different refresh intervals, the initial data is output.

### When the measurement data can be integrated at the start of measurement

Example: When the recording interval is 200 ms, the refresh interval for module 1 is 200 ms, and the refresh interval for module 2 is 1 s

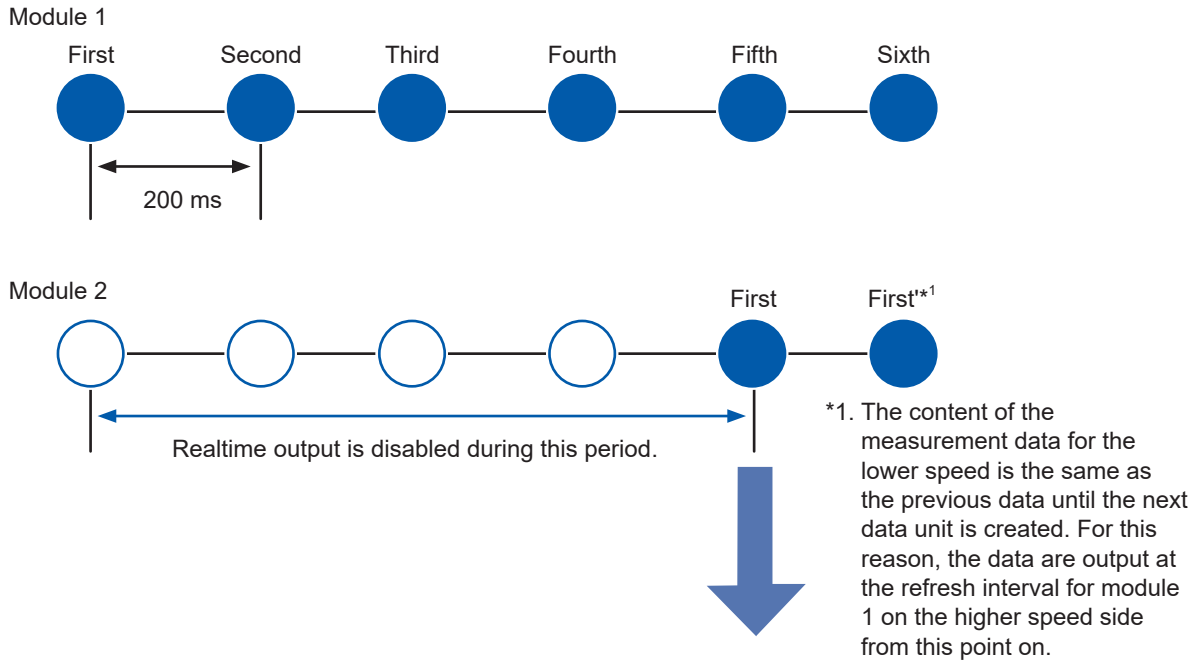

The measurement data do not progress until the lower speed data become ready. Once the lower speed data become ready, the data for both the higher speed and lower speed will progress. At this point, the initial data of the summarized data is output. (The first to fifth data units of module 1 and the first data unit of module 2 in the above drawing)

At this point, the data number used at the start of the output is assigned to the UDP data frame for outputting the measured value of LAN 2. In the above case, for example, data are output from the sixth data unit for module 1, and the data number assigned to the UDP data frame starts from 5.

**Tips** **How to output the data numbers for the UDP data frame from 0 under the above condition**

If you wish to output the data numbers from 0 under the above condition, use the trigger function. Enable the trigger function and external trigger\*2, and also use the manual trigger command. The output will start from data number 0 when the manual trigger command is received.

\*2. As long as the manual command can be received in a trigger standby state, a trigger other than the external trigger can also be used.  
 See "5.2 Enabling the Trigger Function" (p. 139),  
 "5.5 Applying External Trigger" (p. 153), and  
 "5.7 Applying Trigger Forcibly" (p. 156).

## 14.15 Command Samples

This section provides samples of the basic commands to perform measurement with the instrument. The header setting is OFF in these examples.

The order of the command table is as follows.

Sending command → Response to query → Sending command

M7100 is connected to module 1 in these examples.

### (1) Basic setting examples

See “3.3 Setting Measurement Conditions” (p. 82).

| Sending command                            | Response to query command | Description   |
|--|---------------------------|---|
| *ESR?                                      | 128                       | Check ESR first. The value of bit 8 is set after the power is turned ON.              |
| :CONFigure:SAMPle 1E-2                     | –                         | Set the recording interval to 10 ms.  |
| :CONFigure:RECTime 0,0,0,0                 | –                         | Set to the continuous measurement.  |
| :MODule:INMOde CH1_1,VOLTAGE               | –                         | Set CH1_1 to voltage measurement.   |
| :MODule:RANGe CH1_1,1E-1                   | –                         | Set the voltage range of CH1_1 to 100 mV.   |
| :MODule:INMOde CH1_2,TC                    | –                         | Set CH1_2 to thermocouple measurement.  |
| :MODule:SENSor CH1_2,K                     | –                         | Set the type of thermocouple to be used in CH1_2 to K.                                |
| :MODule:RANGe CH1_2,1E+2                   | –                         | Set the range of thermocouple to be used in CH1_2 to 100°C.                           |
| :MODule:STORE<br>CH1_3,OFF;STORE CH1_4,OFF | –                         | Set CH1_3 and CH1_4 to OFF.<br>See “Abbreviation of combined command header” (p. 25). |
| *ESR?                                      | 0                         | Check whether or not the command contains any errors.                                 |

### (2) Measurement and data acquisition (VREAL)

See “4.2 Acquiring Realtime Data” (p. 127).

Use the same settings as with (1) Basic setting examples.

| Sending command      | Response to query command | Description   |
|----------------------|---------------------------|---|
| *ESR?                | 128                       | Check ESR first. The value of bit 8 is set after the power is turned ON.                                |
| :START               | –                         | Starts measurement.   |
| :MEMory:AMAXPoint?   | 10                        | Check the number of measurement data. Repeat until a desired number of data are accumulated, as needed. |
| :MEMory:VREAL? CH1_1 | 1.230000E-02              | Latest voltage value in CH1_1   |
| :MEMory:VREAL? CH1_2 | 2.460000E+01              | Latest temperature value in CH1_2   |
| :STOP;:STOP          | –                         | In the continuous measurement, send the <b>STOP</b> command 2 times to stop the measurement.            |
| *ESR?                | 0                         | Check whether or not the command contains any errors.   |

**(3) Measurement and data acquisition (VDATA)**

See "4.1 Acquiring Measurement Data on Internal Memory" (p. 124).

Use the same settings as with (1) Basic setting examples.

| Sending command          | Response to query command       | Description   |
|--------------------------|---------------------------------|---|
| *ESR?                    | 128                             | Check ESR first. The value of bit 8 is set after the power is turned ON.                                |
| :START                   | –                               | Starts measurement.   |
| :MEMory:AMAXPoint?       | 4                               | Check the number of measurement data. Repeat until a desired number of data are accumulated, as needed. |
| :MEMory:TOPPoint?        | 1                               | Check the leading data number on the internal memory.   |
| :MEMory:APOINT CH1_2,0*1 | –                               | Set the data acquisition position to number 0 in CH1_2.   |
| :MEMory:VDATA? 2*2       | +2.310000E+00,<br>+2.320000E+00 | Acquire 2 starting from data number 0 in CH1_2 as specified in *1.                                      |
| :MEMory:VDATA? 2         | +2.330000E+00,<br>+2.340000E+00 | Acquire 2 data continued from *2.   |
| :STOP;:STOP              | –                               | In the continuous measurement, send the <b>STOP</b> command 2 times to stop the measurement.            |
| *ESR?                    | 0                               | Check whether or not the command contains any errors.   |

## 14.16 File Name and Directory Name

The following single-byte alphanumeric characters and symbols can be used in the file name.

|   |    |   |   |   |   |   |   |   |   |   |   |   |   |   |
|---|----|---|---|---|---|---|---|---|---|---|---|---|---|---|
| 0 | 1  | 2 | 3 | 4 | 5 | 6 | 7 | 8 | 9 |   |   |   |   |   |
| A | B  | C | D | E | F | G | H | I | J | K | L | M | N | O |
| P | Q  | R | S | T | U | V | W | X | Y | Z |   |   |   |   |
| a | b  | c | d | e | f | g | h | i | j | k | l | m | n | o |
| p | q  | r | s | t | u | v | w | x | y | z |   |   |   |   |
| # | \$ | % | & | ' | ( | ) | - | ~ | @ | ^ | _ | { | } |   |

The following single-byte alphanumeric characters and symbols can be used in the destination directory name for FTP auto send.

|   |    |   |   |   |   |   |   |   |   |   |   |   |   |   |
|---|----|---|---|---|---|---|---|---|---|---|---|---|---|---|
| 0 | 1  | 2 | 3 | 4 | 5 | 6 | 7 | 8 | 9 |   |   |   |   |   |
| A | B  | C | D | E | F | G | H | I | J | K | L | M | N | O |
| P | Q  | R | S | T | U | V | W | X | Y | Z |   |   |   |   |
| a | b  | c | d | e | f | g | h | i | j | k | l | m | n | o |
| p | q  | r | s | t | u | v | w | x | y | z |   |   |   |   |
| # | \$ | % | ( | ) | / | = | [ | ] | @ | _ | { | } |   |   |

# 14.17 External View

## LR8101

Unit: mm

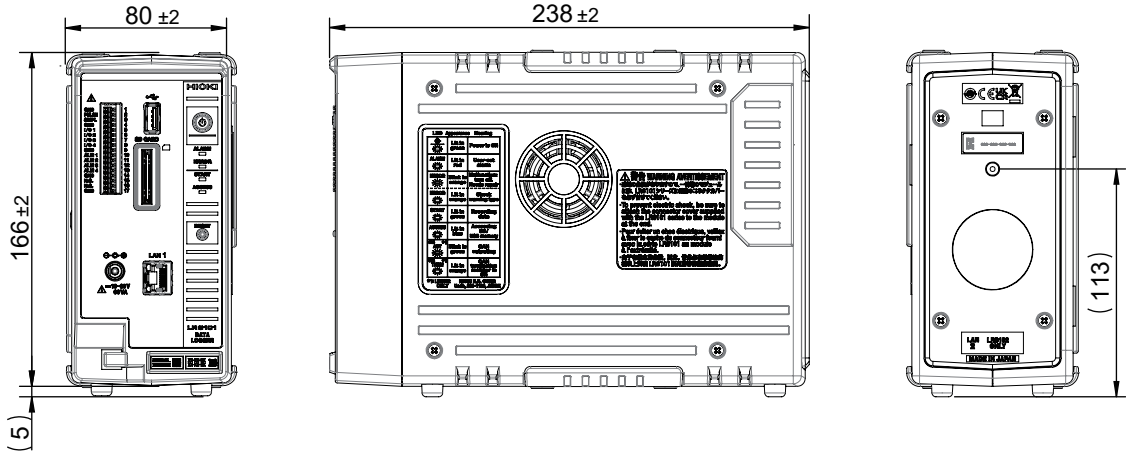

## LR8102

Unit: mm

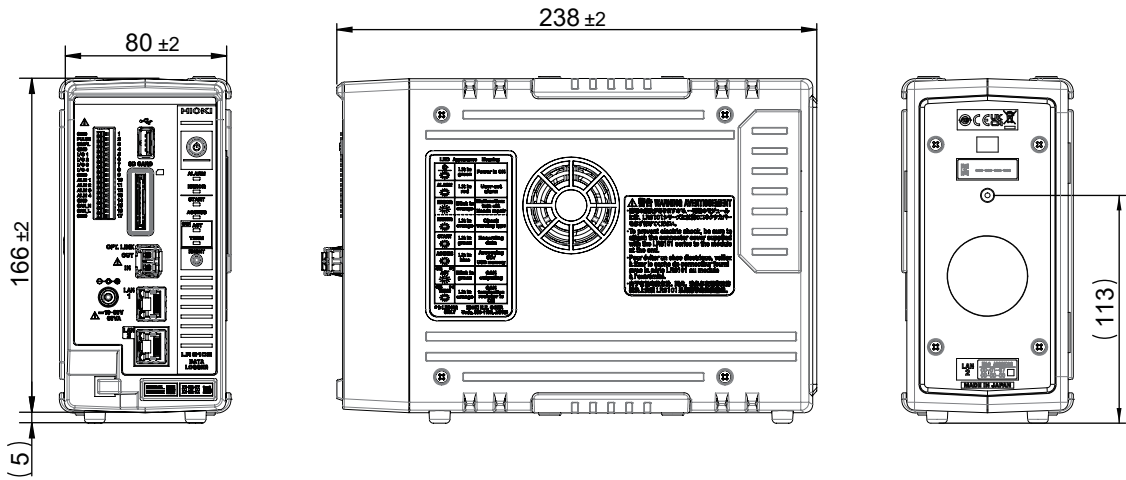



# M7100

Unit: mm

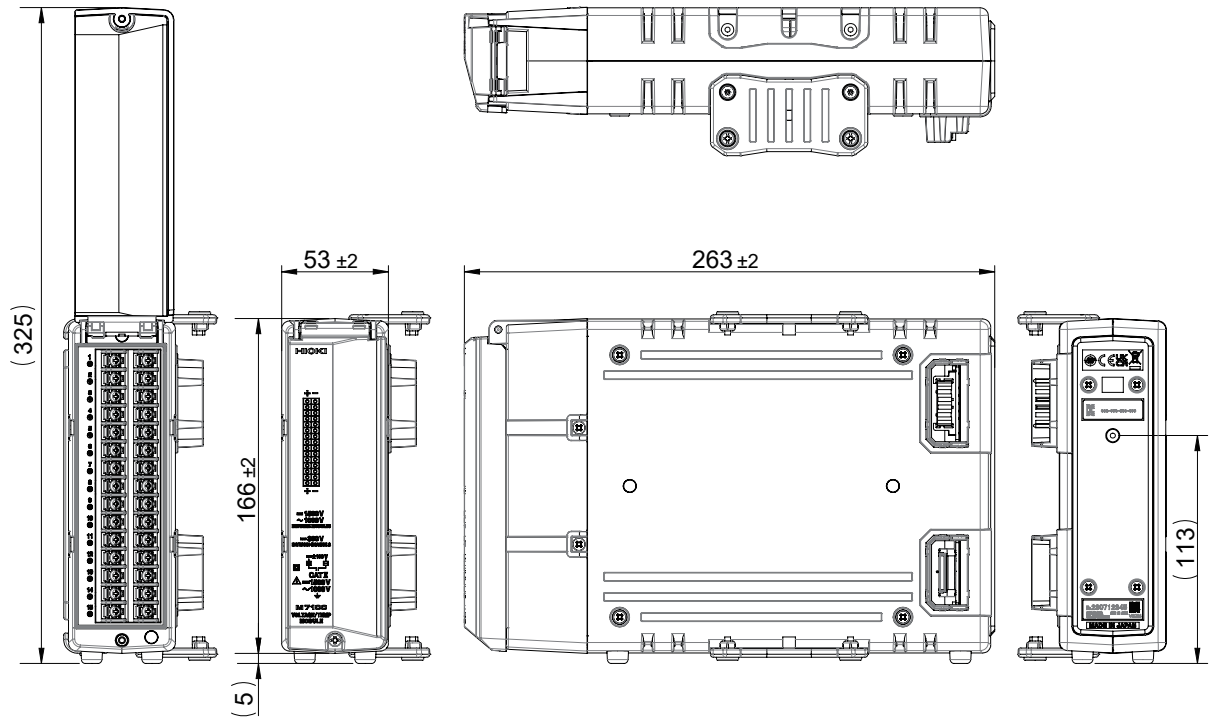

# M7102

Unit: mm

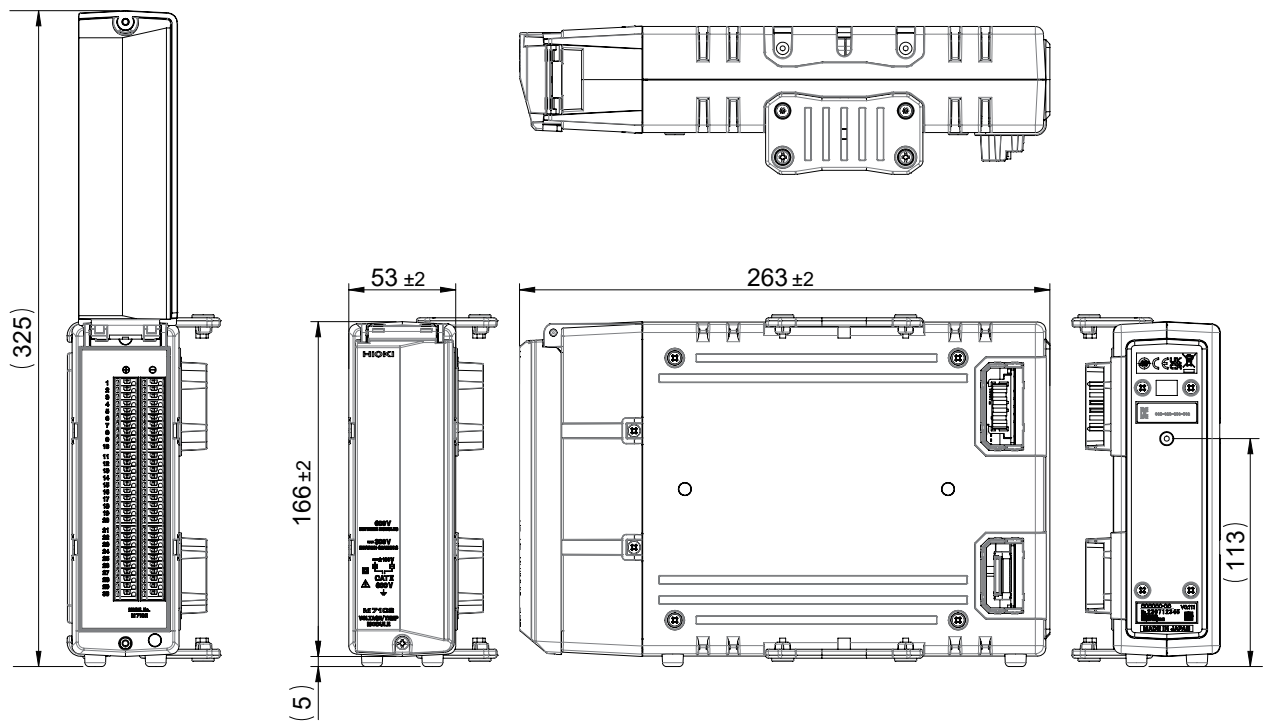

## 6 units of M7100 are connected

Unit: mm

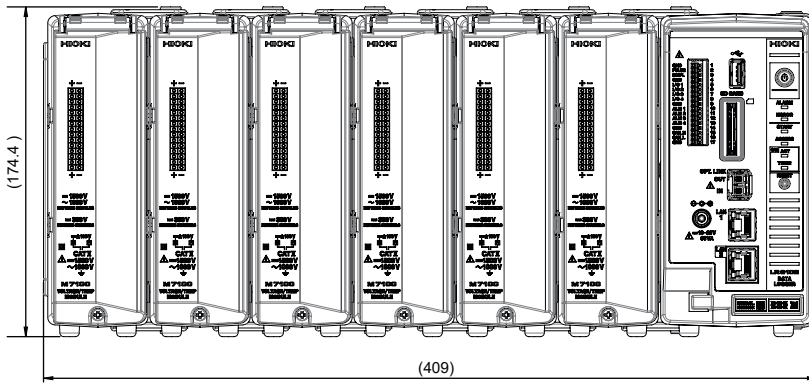

## 10 units of M7100 are connected

Unit: mm

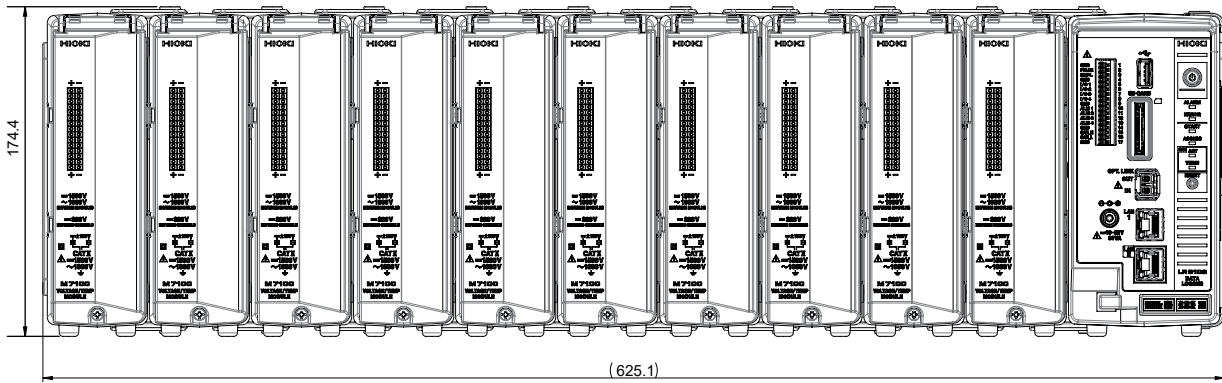

# 15 Maintenance and Service

## 15.1 Repair, Correction, and Cleaning

### Replaceable parts and service life

Some parts used in the instrument are characterized by performance that degrades over years of use.

It is recommended to replace these parts regularly to ensure instrument functionality over the long term.

To order replacements, please contact your authorized Hioki distributor or reseller.

The service life of parts varies depending on the usage environment and frequency.

These parts are not guaranteed to operate throughout the period defined by the recommended replacement interval.

| Parts                             | Recommended replacement cycle | Remarks   |
|-----------------------------------|-------------------------------|---|
| Electrical double layer capacitor | Approx 4 years                | Requires replacement of the printed circuit boards on which such parts are mounted.           |
| Electrolytic capacitor            | Approx. 10 years              |   |
| Backup battery                    | Approx. 10 years              | Requires replacement if the clock is significantly deviated when the instrument is turned ON. |
| Fan motor                         | Approx. 10 years              | At 23°C   |

### Fuse

The instrument's power supply has a built-in fuse. If the instrument cannot be turned ON, the fuse may have blown. Fuses cannot be repaired or replaced by the customer. Contact your authorized Hioki distributor or reseller.

### Calibration

The calibration interval depends on factors such as the operating conditions and environment. Please determine the appropriate calibration interval based on your operating conditions and environment and have Hioki calibrate the instrument accordingly on a regular basis.

### Backing up data

When repairing or calibrating the instrument, we may initialize it or update it to the latest software version. It is recommended to back up (save/write) data such as the settings and measurement data before requesting service.

## Transporting the instrument

### CAUTION

When transporting the instrument, follow the precautions below.



- Remove the measurement modules, storage media, accessories, and accessories from the instrument.
- When requesting repair, attach a note describing the details of the malfunction.
- Use the original packing materials that were provided when the instrument was delivered, and double-pack it.

Failure to do so could damage the instrument, etc., during transportation.

## Cleaning

### CAUTION

- If the instrument becomes dirty, wipe the instrument softly with a soft cloth moistened with water or a neutral detergent.



Do not wipe the instrument strongly and never use solvents such as benzine, alcohol, acetone, ether, ketones, thinners, or gasoline. Failure to follow this instructions can deform and discolor the instrument.

- Periodically clean the vents to avoid blockage.

When the vents become clogged, the internal cooling effect of the instrument is hampered, and this can lead to damage to the instrument.

## 15.2 Troubleshooting

If damage is suspected, read “Before returning for repair” (p. 349) to remedy the issue. If the issue cannot be resolved, contact your authorized Hioki distributor or reseller.

### Before returning for repair

| Issue   | Cause  | Countermeasures   |
|---|--|---|
| The power supply does not turn on even when you press the power key.              | • The power cord is disconnected.  | Connect the power cord properly. (p.40)   |
|   | • The AC adapter is not outputting 12 V DC.  | The AC adapter cannot be repaired by the customer.<br>Contact your authorized Hioki distributor or reseller.  |
| The measured value cannot be acquired even when the measurement has been started. | • The pre-trigger is set to be used. (When the pre-trigger is set, the trigger is not accepted until the waveform acquisition for the pre-trigger is completed.) | Disable the pre-trigger setting if the pre-trigger is not used. (p.140)   |
|   | • The trigger is set to be used.   | Set the trigger function to OFF if the trigger is not used. (p.139)   |
| The measured value does not change.   | • The cables are disconnected or broken.   | Connect the cables properly. (p.42)   |
|   | • The range setting is not appropriate.  | Set an appropriate range. (p.94)  |
| Cannot save data to the media (SD memory card, USB drive).                        | • A medium other than Hioki optional parts is used.  | Make sure to use Hioki optional SD memory card or USB drive.<br>The operation cannot be guaranteed if a medium other than Hioki optional parts is used.                     |
|   | • The medium is not inserted securely.   | Insert the medium securely. (p.56)  |
|   | • The medium is not formatted (initialized).   | Format the media before the first use. (p.162)  |
|   | • Free space on the media is insufficient.   | Format or replace the media.  |
|   | • The number of files in the folder is 1000 or more.   | Keep the number of files save in one folder 1000 or less.<br>Although more than 1000 files can be saved, it takes a longer time for saving as the number of files increase. |

#### If the cause of your problem remains unclear

Perform the system reset (initialization).

See “Initialization” (p. 234) and

“14.8 Settings After Initialization (System Reset)” (p. 329).

#### When the power cannot be turned OFF

Hold down the POWER key for 5 seconds. This will turn OFF the power forcibly.

## Error messages

Error messages include “errors” and “warnings”.

When an error or warning has occurred in the instrument, the issuance status can be checked using the communication commands.

Refer to the table and the command below for the details and countermeasures for the error.

Note that measurement stops if an error occurs.

### 1 Query errors in the instrument.

The number of the error or warning that has occurred in the instrument is returned.

If the `:ERRor?` query is sent immediately after an error occurs, the information on the previous error may be returned. In such a case, send the `:ERRor?` query again.

| Query   |   |                      |
|---------|---|----------------------|
| Syntax  | Query   | <code>:ERRor?</code> |
|         | Response  | <code>A\$</code>     |
| Example | <code>:ERRor?</code><br>(Response) <code>:ERROR ERR_SY01</code> (When the header is ON) |                      |

### 2 Read out the error bit.

The status of the error that has occurred in the instrument is returned in bit format (as a hexadecimal character string).

The statuses of all errors occurred in the instrument can be acquired at once. Refer to the bit numbers in “Error messages” (p. 352).

Example: If ERR\_SY02, ERR\_SY06, ERR\_SY07, and ERR\_SY08 have occurred, the error status is “e2”.

| Query   |   |                                |
|---------|---|--------------------------------|
| Syntax  | Query   | <code>:ERRor:BIT:ERRor?</code> |
|         | Response  | <code>A\$</code>               |
| Example | <code>:ERRor:BIT:ERRor?</code><br>(Response) <code>:ERROR:BIT:ERROR 0~ffffffffffffffffffffffffffff</code> (When the header is ON) |                                |

### 3 Read out the warning bit.

The status of the warning occurred in the instrument is returned in bit format (in hexadecimal character strings).

The statuses of all warnings occurred in the instrument can be acquired at once. Refer to the bit numbers in “Warning messages” (p. 353).

Example: If WARN\_SY03, WARN\_SY06, and WARN\_FL02 have occurred, the warning status is “200024”.

| Query   |  |                                  |
|---------|--|----------------------------------|
| Syntax  | Query  | <code>:ERRor:BIT:WARNing?</code> |
|         | Response   | <code>A\$</code>                 |
| Example | <code>:ERRor:BIT:WARNing?</code><br>(Response) <code>:ERROR:BIT:WARNING 0~ffffffffffffffffffffffffffff</code><br>(When the header is ON) |                                  |

#### 4 Clear the warning bit.

Clear the statuses of the warnings occurred in the instrument.

| Settings |                          |                          |
|----------|--------------------------|--------------------------|
| Syntax   | Query                    | :ERRor:BIT:WARNing:CLEAr |
| Example  | :ERRor:BIT:WARNing:CLEAr |                          |

#### 5 Read out the error log.

Acquire the error log saved in the instrument. The latest 50 logs can be saved.

(no\$ 1 to 50)

If there is no log, the response is "---".

| Query   |   |                        |
|---------|---|------------------------|
| Syntax  | Query   | :ERRor:LOG:ERRor? no\$ |
|         | Response  | A\$                    |
| Example | :ERRor:LOG:ERRor? 1<br>(Response) :ERRor:LOG:ERRor: 2023/01/23 12:34:56 - ERR_SY01<br>(When the header is ON) |                        |

#### 6 Clear the error log.

Clear the error log saved in the instrument.

| Settings |                        |                        |
|----------|------------------------|------------------------|
| Syntax   | Query                  | :ERRor:LOG:ERRor:CLEAr |
| Example  | :ERRor:LOG:ERRor:CLEAr |                        |

#### 7 Read out the warning log.

Acquire the warning log saved in the instrument. The latest 50 logs can be saved.

(no\$ 1 to 50)

If there is no log, the response is "---".

| Query   |  |                          |
|---------|--|--------------------------|
| Syntax  | Query  | :ERRor:LOG:WARNing? no\$ |
|         | Response   | A\$                      |
| Example | :ERRor:LOG:WARNing? 1<br>(Response) :WARNing:LOG:WARNing: 2023/01/23 12:34:56 - WARN_SY01<br>(When the header is ON) |                          |

#### 8 Clear the warning log.

Clear the warning log saved in the instrument.

| Settings |                          |                          |
|----------|--------------------------|--------------------------|
| Syntax   | Query                    | :ERRor:LOG:WARNing:CLEAr |
| Example  | :ERRor:LOG:WARNing:CLEAr |                          |

## Error messages

| No.      | Bit number | Description   | Countermeasures  |
|----------|------------|---|--|
| ERR_SY01 | 0          | Program failure.<br>Repair required.                | Turn OFF the power and request repair.   |
| ERR_SY03 | 2          | Clock correction circuit error. Repair required.    | Turn OFF the power and request repair.   |
| ERR_SY04 | 3          | Internal temperature of the instrument is abnormal. | Check the operating temperature environment and the status of the fan rotation.<br>If this message is displayed even within the operating temperature range, request repair. |
| ERR_SY05 | 4          | Hardware error detected.                            | Turn OFF the power and request repair.   |
| ERR_SY06 | 5          | Module error Module No.1                            | The module cannot be recognized normally. The module may be malfunctioning. Request repair.  |
| ERR_SY07 | 6          | Module error Module No.2                            |  |
| ERR_SY08 | 7          | Module error Module No.3                            |  |
| ERR_SY09 | 8          | Module error Module No.4                            |  |
| ERR_SY10 | 9          | Module error Module No.5                            |  |
| ERR_SY11 | 10         | Module error Module No.6                            |  |
| ERR_SY12 | 11         | Module error Module No.7                            |  |
| ERR_SY13 | 12         | Module error Module No.8                            |  |
| ERR_SY14 | 13         | Module error Module No.9                            |  |
| ERR_SY15 | 14         | Module error Module No.10                           |  |
| ERR_SY16 | 15         | CAN controller error                                | Turn OFF the power and request repair.   |
| ERR_SY17 | 16         | The fan of the instrument is abnormal.              |  |



## Warning messages

| No.       | Bit number | Description   | Countermeasures   |
|-----------|------------|---|---|
| WARN_SY01 | 0          | Failed to upgrade.  | Turn OFF the power and perform the upgrade again. If the upgrade fails again, request repair.   |
| WARN_SY02 | 1          | Internal temperature of the instrument has risen.<br>Check the operating environment.               | Check the state of the instrument's installation.<br>See "Installing the instrument" (p. 13).   |
| WARN_SY03 | 2          | Internal temperature of the instrument has risen.<br>Check the operating environment.               | Check the state of the instrument's installation.<br>See "Installing the instrument" (p. 13).   |
| WARN_SY04 | 3          | No channel selected for measurement.  | Measurement is set to OFF in all channels. Set the measurement to ON in one or more channels and then start the measurement.<br>While measurement is set to OFF for all channels, if measurement is started using a communication command, a "WARN_COM02" communication command error occurs. |
| WARN_SY05 | 4          | Failed to initialize.   | Perform the initialization again. This warning can occur due to a key operation during the initialization. Do not operate any keys during initialization.   |
| WARN_SY06 | 5          | System warning (SY06).<br>Turn ON the instrument again.   | Turn OFF the instrument and then turn it ON again.  |
| WARN_SY07 | 6          | The wiring is abnormal.<br>Check the connection and settings of the primary and secondary units.    | Check the connection and settings of the primary and secondary units. (p.53, p.89)  |
| WARN_SY08 | 7          | Measurement is stopped, because the synchronization signal is stopped.                              | Turn OFF the instrument and then turn it ON again.  |
| WARN_SY09 | 8          | Module connection error<br>The current module configuration cannot be used. Review the connections. | Verify that the measurement modules are connected properly.   |
| WARN_FL01 | 24         | File processing error.  | Unexpected abnormality has occurred while processing files on the SD memory card or USB drive. Replace with other media or turn ON the instrument again.  |
| WARN_FL02 | 25         | Waveform data not found   | Acquire waveform data.  |
| WARN_FL03 | 26         | Numerical calculation data not found  | Perform numerical calculation.  |
| WARN_FL04 | 27         | Cannot load this file   | The selected file is created in the format that the instrument cannot load, or the selected file is corrupt. Load a suitable file.  |
| WARN_FL05 | 28         | Insufficient storage memory   | The file cannot be saved because the available space on the storage medium is low. Delete unnecessary files to secure a sufficient space or use a new medium.   |

| No.        | Bit number | Description  | Countermeasures  |
|------------|------------|--|--|
| WARN_FL06  | 29         | Media is full or cannot delete oldest wave file  | The file could not be saved, because free space on the SD memory card or USB drive is insufficient. Delete unnecessary files to secure a sufficient space or use a new medium.   |
| WARN_FL07  | 30         | This folder cannot be deleted or renamed on the instrument.  | This message is displayed to prevent deletion of the data by an erroneous operation. Use a PC to delete or change the name of the folder.  |
| WARN_FL08  | 31         | File is damaged  | The file cannot be loaded, because the information in the file is damaged. Load a suitable file.   |
| WARN_FL10  | 33         | This folder/file is protected.   | The read-only folders and files cannot be deleted. Use a PC to delete these folders or files.  |
| WARN_FL11  | 34         | Data cannot be loaded, because the model configuration of the modules directly connected to the instrument does not match the model configuration in the file.   | Data can be loaded in overwrite mode if the configuration of the plug-in modules is the same as the configuration of plug-in modules when the data are saved. Check the module configuration in the browsing mode.   |
| WARN_FL12  | 35         | Storage media not found.   | Insert an SD memory card or USB drive.   |
| WARN_FL13  | 36         | Insert SD memory card or USB drive.  | Insert an SD memory card or USB drive  |
| WARN_FL14  | 37         | Storage media is almost full   | Free space on the media is insufficient. Replace with a new medium.  |
| WARN_FL15  | 28         | Unsaved data will be deleted shortly. Please insert storage media.   | If the realtime save operation is started without inserting any media, this warning is displayed when the data on the internal buffer memory exceeds 50%. Insert an SD memory card or USB drive  |
| WARN_FL16  | 39         | Unsaved data present.  | It is possible that no SD memory card or USB drive is inserted or free space is insufficient. Insert an SD memory card or USB drive and save the necessary data manually.  |
| WARN_FL17  | 40         | File name including the folder is too long - file operation unsuccessful.  | The specified path name is too long. Use a PC to shorten the name of folders saved on the SD memory card or USB drive.   |
| WARN_FL18  | 41         | Busy   | Wait for the process to be completed before proceeding with any operations.  |
| WARN_SU04  | 59         | Measurement cannot be started with the current settings. Please optimize the following settings. For details, see the instruction manual.<br><ul style="list-style-type: none"> <li>• Recording interval</li> <li>• Number of measurement ON channels</li> <li>• Auto save format</li> </ul> | The number of channels that can be used is limited depending on the recording interval and auto-save settings.<br><ul style="list-style-type: none"> <li>• Recording interval (p.291)</li> <li>• Number of measurement ON channels (p.291)</li> <li>• Auto save format (p. 164)</li> </ul> |
| WARN_COM02 | 65         | Communication command error  | Check the content of the communication command.  |

| No.        | Bit number | Description                               | Countermeasures  |
|------------|------------|---|--|
| WARN_COM03 | 66         | No communication command is input.        | Check the content of the communication command.  |
| WARN_FTP01 | 72         | Failed to connect to FTP server           | Check the FTP data auto send setting and the connection.   |
| WARN_FTP02 | 73         | FTP data transfer failed. File not found. | Manually acquire the file that has not been sent from the instrument using FTP, or load the file from the recording destination media. |

## Normalization process

When settings are changed or measurement is started, the settings may be automatically changed (normalized) according to various limitations of the settings. Check the status using the following command and the table below.

Read out the normalization bit.

The value is returned in hexadecimal character strings and the bit is cleared.

| Query  |   |           |
|--|---|-----------|
| Syntax   | Query   | :NRMFlag? |
|  | Response  | A\$       |
| Example  | :NRMFlag?<br>(Response) :NRMFLAG 3b (when the header is ON and normalization of bit numbers 1, 2, 4, 5, and 6 has occurred) |           |
| Parameter  |   |           |
| A\$ = 0 to fffffff   |   |           |
| Example: In the case of 3b, it is 00111011 in a binary character string, and the contents of bit numbers 0, 1, 3, 4, and 5 are normalized. |   |           |

### Normalization bit and contents

| Bit number | Target   | Description  |
|------------|--|--|
| 0          | Others   | Normalization of other than those described below.   |
| 1          | Recording interval   | Normalization of the recording interval  |
| 2          | External input terminal (I/O 3)                                    | If the external trigger setting is ON, changes the external input terminal (I/O 3) setting to the trigger input.   |
| 3          | Recording time   | Changes the recording time according to the number of channels to be used and the recording interval.  |
| 4          | Waveform data division time in the auto-save operation             | Changes the waveform data division time according to the recording interval.   |
| 5          | Numerical calculation result split time in the auto-save operation | Changes the split time numerical calculation results according to the recording interval.  |
| 6          | Pre-trigger time   | Changes the pre-trigger time according to the recording interval.  |
| 7          | Data refresh interval of module                                    | Changes the data refresh interval of module according to the recording interval.   |
| 8          | Waveform data saving format in the auto-save operation             | Changes the waveform data saving format according to the number of channels to be used and the recording interval. See "Auto save (Realtime save)" (p. 164).             |
| 9          | Repetitive recording   | If the interval trigger is set to ON, changes the repetitive recording setting to ON. See "5.6 Applying Triggers at Constant Intervals" (p. 154).                        |
| 10         | Interval trigger   | If the repetitive recording is set to OFF, changes the interval trigger setting to OFF. See "5.6 Applying Triggers at Constant Intervals" (p. 154).                      |
| 12         | Measurement start time and measurement stop time                   | Changes the measurement start time and measurement stop time. See "4 Set the measurement start time." (p. 87) and "5 Set the measurement stop time." (p. 84).            |
| 13         | Burnout detection  | Changes the burnout detection setting to OFF in accordance with the change in the data refresh interval. See "Data refresh interval of the measurement modules" (p. 90). |



## 15.3 Disposal

Backup lithium batteries are built into the instrument. When disposing of the instrument, remove the lithium batteries and handle and dispose of the instrument in accordance with local regulations.

### **DANGER**

- Do not short-circuit the battery.
  - Do not charge the battery.
  -  ■ Do not disassemble the battery.
  - Do not throw the battery in the fire or heat the battery.
- Doing so can cause the battery to explode, resulting in bodily injury.

### **WARNING**

-  ■ **Before removing the lithium battery, turn OFF the instrument and remove the power cord and the cables.**  
Failure to do so could cause the operator to experience an electric shock.
-  ■ **Keep the removed battery out of reach of children.**  
Children may accidentally swallow the battery.

Dispose of the battery in accordance with local regulations.

CALIFORNIA, USA ONLY  
Perchlorate Material - special handling may apply.  
See <https://dtsc.ca.gov/perchlorate/>

## How to remove lithium batteries

Required items: Phillips screwdriver (No. 2), tweezers

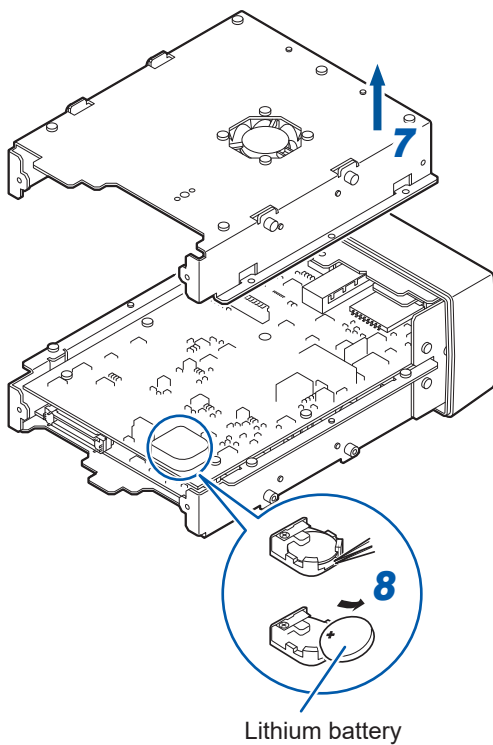
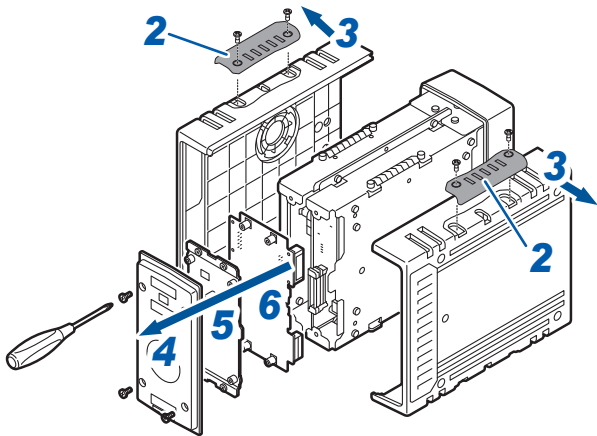

- 1** Confirm that the instrument is turned OFF. Remove the power cord and the cables.
- 2** Remove the cover. (4 locations)
- 3** Remove the side panels on both sides.
- 4** Remove the rear panel.
- 5** Remove the plate at the rear.
- 6** Remove the motherboard.
- 7** Remove the plate.
- 8** Insert a pair of tweezers between the battery and the battery holder, and then lift up the battery to remove it.

## 15.4 FAQ (Frequently Asked Questions)

### Installation and measurement operation

| Query  | Answer  | Reference   |
|--|---|---|
| What is the power consumption of a measurement module?   | The power consumption of the modules directly connected to the instrument when using the AC adapter or 12 V DC external power supply are shown below (reference values at 23°C).<br>• M7100: 3.2 VA<br>• M7102: 3.0 VA  | –   |
| What happens to the data if a power failure occurs during the measurement?   | The measurement data cannot be retained.  | “Preparations and settings in case of power failure” (p. 161),<br>“Start backup” (p. 225) |
| What can I do to restart the recording after the power is restored?  | The recording can be restarted after the power is restored by using the start backup function.  | “10.1 Setting the Environment” (p. 225)   |
| Why is the temperature error increased immediately after the instrument is moved to a location with a significantly different temperature? | For the temperature measurement using a thermocouple, the reference junction compensation is performed by measuring the terminal temperature using the internal temperature sensor. If the environment temperature changes drastically, the thermal equilibrium between the terminal block and the temperature sensor is disrupted, causing the error. When the instrument is moved to a location with a significantly different temperature, wait for at least 60 minutes before performing measurement. | “Installing the instrument” (p. 13)   |
| What can I do to correct a deviation in the zero position of the input?  | The deviation in the zero position can be corrected using the zero adjustment function.   | “Performing Zero Adjustment” (p. 117)   |
| What should I do if a measured value appears in an unconnected channel even when only CH1 is input?  | When the input terminal is open, it may display a waveform affected by other channels. Set the input open channel to OFF or short the plus and minus terminals.   | –   |
| The measured value fluctuates even when there is no input. What should I do?   | Due to induced voltage, the measured value may become unstable; however, this is not a malfunction.   | –   |
| Is it possible to place event marks during the measurement and search for them later?  | Event marks can be placed on the measurement data. Use Logger Utility to jump to the display of the event mark.   | “8.1 Placing Event Marks During Measurement” (p. 205)                                     |
| The measured value cannot be acquired after the measurement has been started.  | If the trigger is set, the recording is not started until the trigger is activated.<br>You can activate the trigger forcibly.   | “5 Trigger Function” (p. 137),<br>“5.7 Applying Trigger Forcibly” (p. 156)                |

## Settings

| Query   | Answer   | Reference  |
|---|--|--|
| Is it possible to measure the temperature of the part where voltage is applied?                                   | The temperature can be measured if the voltage is not exceeding the maximum voltage between channels and the maximum voltage to the ground connection. If the voltage exceeds the maximum voltages, use an ungrounded thermocouple, for example, so that the voltage will not be applied to the input terminal.  | "Precautions for measurement" (p. 15)            |
| Which should I set for the reference junction compensation, [EXT] or [INT]?<br>What is the accuracy in this case? | To connect a thermocouple to the terminal block of the module, set INT (internal).<br>The measurement accuracy is the value obtained when the temperature measurement accuracy and reference junction compensation accuracy are added.<br>Example: When measuring the temperature in the range between 0°C and 100°C using thermocouple K<br>The measurement accuracy is $\pm 1.0^{\circ}\text{C}$ , which is the value obtained when the temperature measurement accuracy $\pm 0.5^{\circ}\text{C}$ and reference junction compensation accuracy $\pm 0.5^{\circ}\text{C}$ are added. | "Temperature (thermocouple) measurement" (p. 96) |

## Data saving

| Query  | Answer   | Reference   |
|--|--|---|
| Can I use a commercially available SD memory card or USB drive?  | Make sure to use Hioki optional SD memory card or USB drive. The operation cannot be guaranteed for a commercially available SD memory card or USB drive.  | "2.7 SD Memory Card and USB Drive" (p. 56)  |
|  | A USB drive with security functions, including fingerprint authentication, cannot be used.   |   |
| Can I replace the media during the auto-save operation?  | You cannot replace the media during the auto-save operation. Try to select split saving, deleting, or FTP function.  | "6.3 Saving Data" (p. 163)<br>"12.3 Acquiring Data with the FTP Server" (p. 262)<br>"12.4 Sending Data Using the FTP Client" (p. 264) |
| How many days can I record data?   | The allowable recording length setting varies with the number of channels and the recording interval.<br>Example: With the recording interval 1 s, 15 channels, and 1 GB media, a recording of approx. 200 days is possible.   | "14.7 File Size" (p. 328)   |
| Can I view the waveform data in Excel?   | Automatically saved waveform data (binary format) can be converted to the text format (CSV) using Logger Utility.<br>The CSV files can be read in Excel.   | "12.1 Using Logger Utility" (p. 249)  |
| I want to set the time (absolute time), instead of the elapsed time (relative time), for the time axis of the waveform data (CSV format).<br>What should I do? | Set the horizontal (time) axis display to date. <ul style="list-style-type: none"> <li>Time: Elapsed time since the measurement is started</li> <li>Date: Actual time (date and time)</li> <li>Number of data: Number of data since the measurement is started.</li> </ul> | "Horizontal (time) axis display" (p. 228)   |



## 15.5 Open-source Software

The product includes software under GNU General Public License, GNU Lesser General Public License, and other licenses.

Under these licenses, the customer has a right to obtain, modify, or redistribute the source codes of the software.

For more information, see the following website.

<https://www.hioki.com/global/support/oss>

Please understand that we cannot answer questions regarding the contents of the source codes.



**HIOKI**  
**www.hioki.com/**



**All regional  
contact  
information**

**HIOKI E.E. CORPORATION**

81 Koizumi, Ueda, Nagano 386-1192 Japan

2309 EN

Edited and published by HIOKI E.E. CORPORATION

Printed in Japan

- Contents subject to change without notice.
- This document contains copyrighted content.
- It is prohibited to copy, reproduce, or modify the content of this document without permission.
- Company names, product names, etc. mentioned in this document are trademarks or registered trademarks of their respective companies.

**Europe only**

•EU declaration of conformity can be downloaded from our website.

•Contact in Europe: HIOKI EUROPE GmbH  
Helfmann-Park 2, 65760 Eschborn, Germany

hioki@hioki.eu